

Size of Mattress and Foundation

The length and width of the upper and lower bunk mattress and foundation are as follows :

<u>Size</u>	<u>Length</u>	<u>Width</u>	<u>Thickness</u>
Twin	74" - 75"	37 ½" - 38 ½"	9 ½" max
Full	74" - 75"	52" - 53"	9 ½" max

You must use only this size mattress.

Ensure thickness of upper and lower mattress and foundation combined does not exceed 9 ½" and that the mattress is at least 5" below upper edge of guardrails.

This Bunk Bed uses a slat kit for mattress foundation.

Replacement Parts

Replacement parts, including additional guardrails, may be obtained from any affurnishings dealer



SAFETY WARNINGS



- (1) Follow the information on the warnings appearing on the upper bunk end structure and on the carton. Do not remove warning label from bed.
- (2) Always use the recommended size mattresses or mattress support, or both, to help prevent the likelihood of entrapment or falls.
- (3) Surface of mattress must be at least 5 in. (127mm) below the upper edge of guardrails.
- (4) Do not allow children under 6 years of age to use the upper bunk.
- (5) Periodically check and ensure that the guardrail, ladder, and other component are in their proper position, free from damage, and that all connectors are tight.
- (6) Do not allow horseplay on or under the bed and prohibit jumping on the bed.
- (7) Always use ladder for entering or leaving upper bunk.
- (8) Do not use substitute parts. Contact the manufacturer or dealer for replacement parts.
- (9) Use of a night light may provide added safety precaution for a child using the upper bunk.
- (10) Always use guardrails on both long sides of the upper bunk. If the bunk bed will be placed next to the wall, the guardrail that runs the full length of the bed should be placed against the wall to prevent entrapment between the bed and the wall.
- (11) The use of water or sleep flotation mattresses is prohibited.
- (12) **STRANGULATION HAZARD** : Never attach or hang items to any part of the bunk bed that are not designed for use with the bed; for example, but not limited to, hooks, belts and jump ropes.
- (13) Keep these instructions for future reference.

ASSEMBLY INSTRUCTIONS (FULL - FULL)

Thank you for choosing our new bunk bed.
This practical design offers the utmost in versatility.

Before assembling your staircase bookshelf bunk bed, please read through these instructions carefully. Familiarize yourself with the different parts.

Please note that you will require a phillips head screwdriver and an allen wrench.

ATTENTION! If you receive a damaged or defective item, please contact afifurnishings at customerservice@afifurnishings.com or 1-800-955-3726

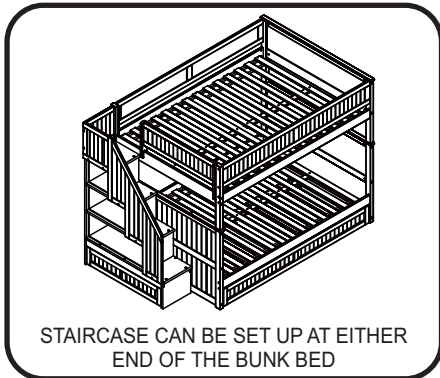
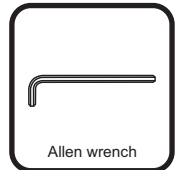
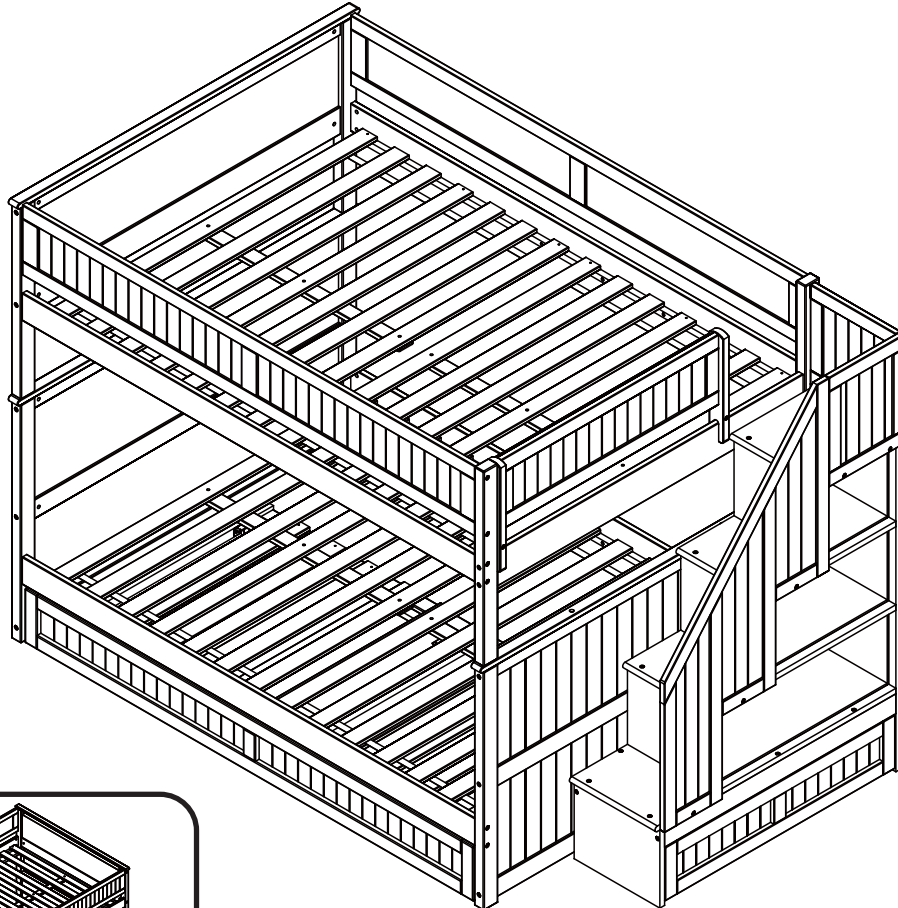

CODE	ITEM
BK-SCPL-DVR	B-6833X

PO: _____

HARDWARE

NOTE: WE INCLUDE SPARE HARDWARE IN CASE DAMAGE OCCURS DURING ASSEMBLY.

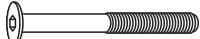
A  JCB M6 X 4" - 20 pcs
Spare - 1 pc

B  Barrel nut - 20 pcs
Spare - 1 pc

C  JCB M6 X 1 1/2" - 2 pcs
Spare - 1 pc

D  Allen wrench - 1 pcs
Spare - 1 pc

(FULL - FULL)

PARTS LIST

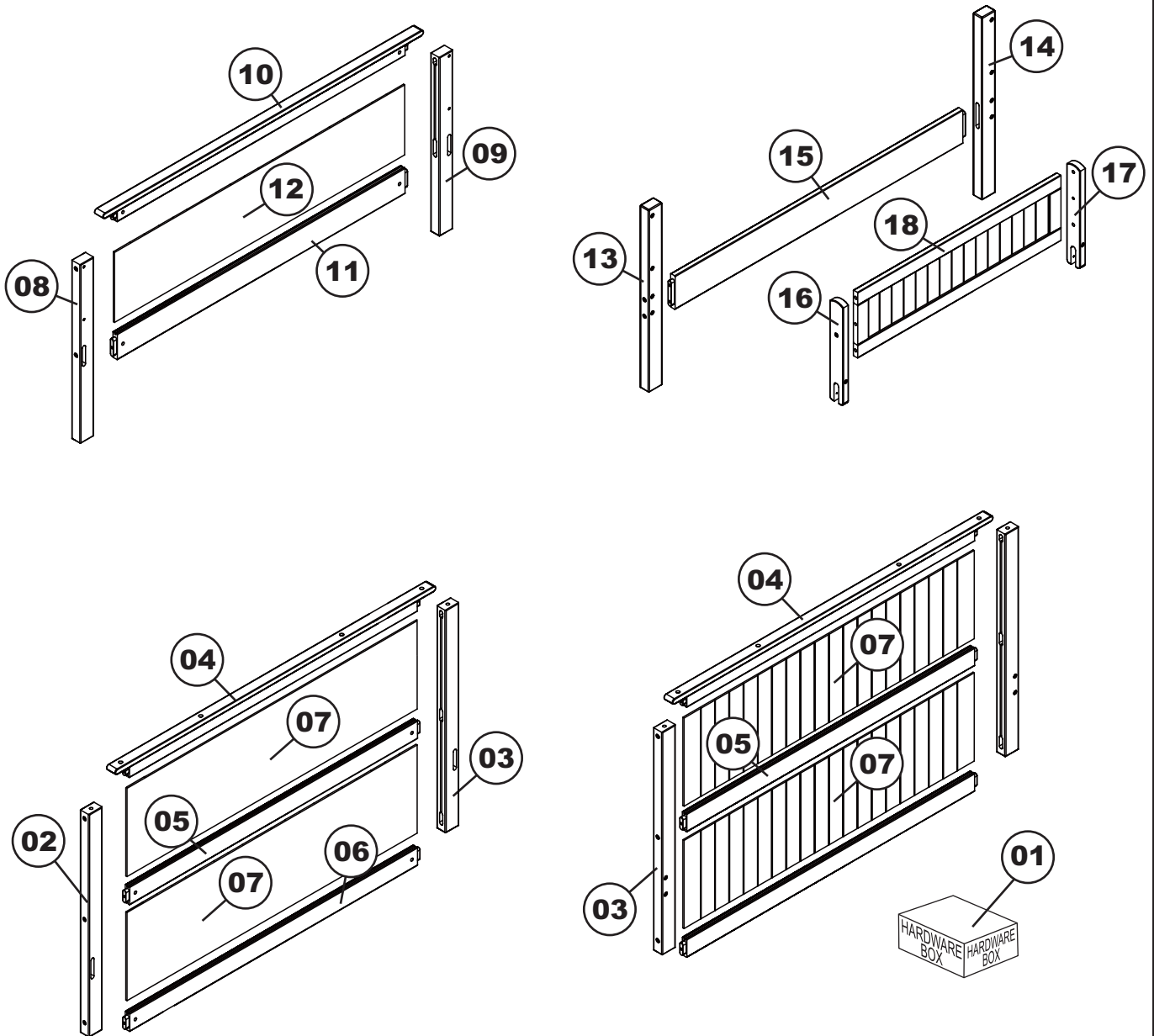

B-6833X

- | | | |
|----------------------|----------------------|---------------------|
| 01 HARDWARE | 07 LOWER PANEL | 13 U2 LEFT POST |
| 02 RIGHT LOWER POST | 08 UPPER LEFT POST | 14 U2 RIGHT POST |
| 03 LEFT LOWER POST | 09 UPPER RIGHT POST | 15 UPPER MID RAIL |
| 04 LOWER TOP REST | 10 UPPER TOP REST | 16 LEFT END CAP |
| 05 LOWER MID RAIL | 11 UPPER BOTTOM RAIL | 17 RIGHT END CAP |
| 06 LOWER BOTTOM RAIL | 12 UPPER PANEL | 18 SHORT GUARD RAIL |

(FULL - FULL)

STEP 1

Attach right lower post (02) to the lower top rest (04) lower middle rail (05), lower bottom rail (06) using JCB M6 X 4" (A) and barrel nut (B). Tighten with the allen wrench (D).

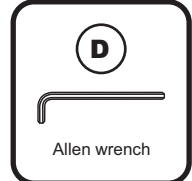
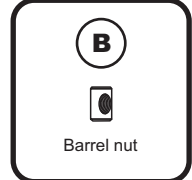
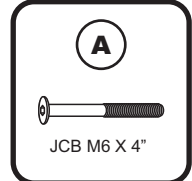
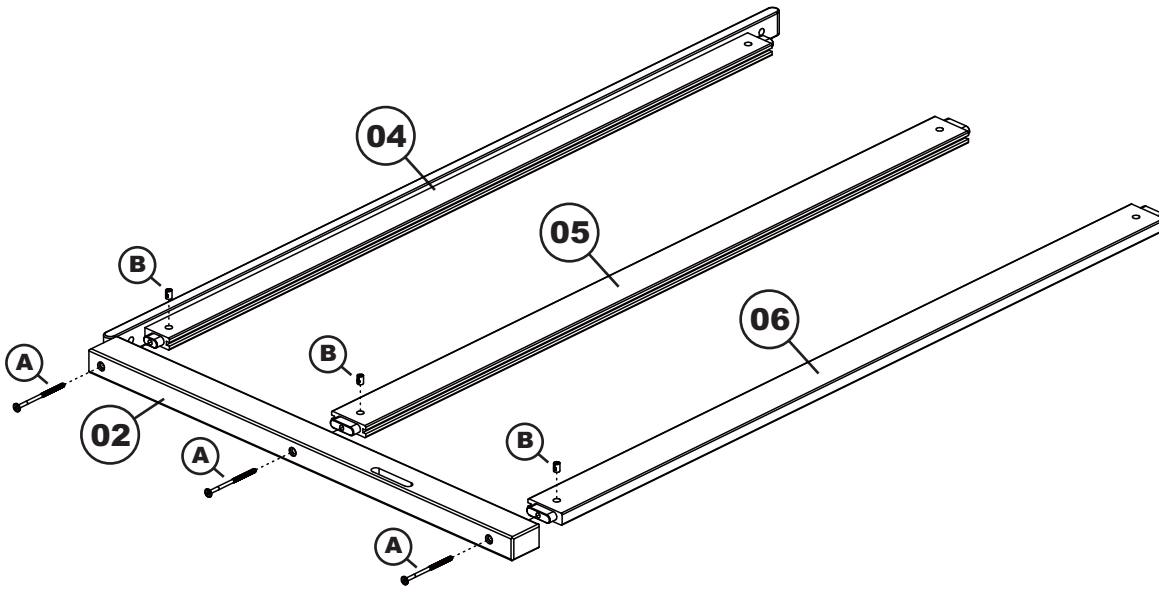

STEP 2

Insert lower panel (07) as shown below. Attach left lower post (03) to the panel assembly as shown below. Using JCB X 4" (A) and barrel nut (B) tighten with allen wrench (D). Repeat for the others.

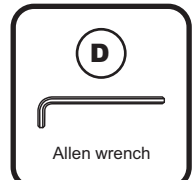
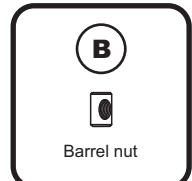
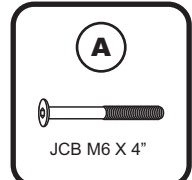
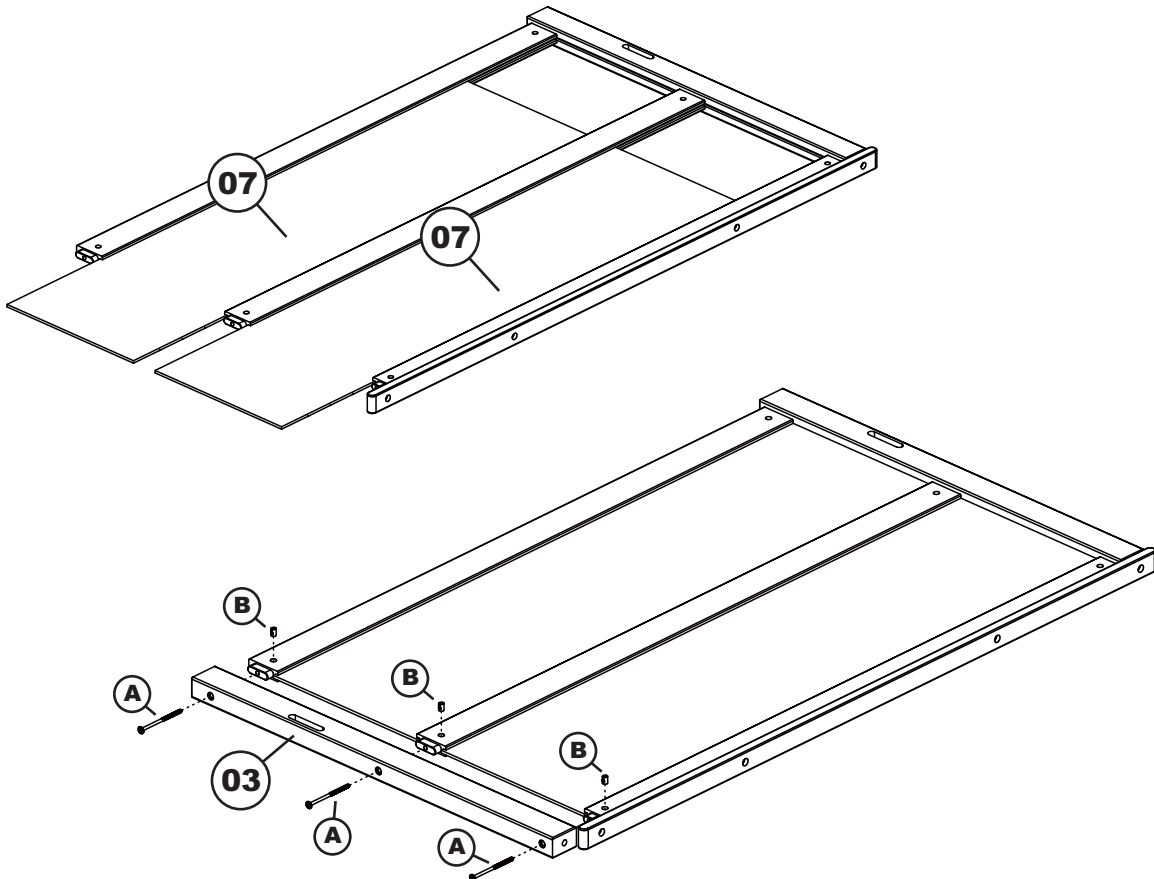

(FULL - FULL)

STEP 3 Attach upper left post (08) to the upper top rest (10) and upper bottom rail (11). Using JCB M6 X 4" (A) and barrel nut (B) tighten with allen wrench (D). Insert upper panel (12) as shown below.

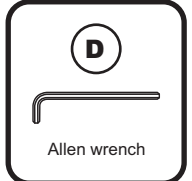
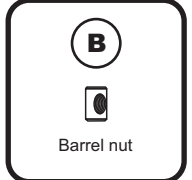
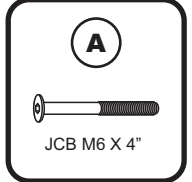
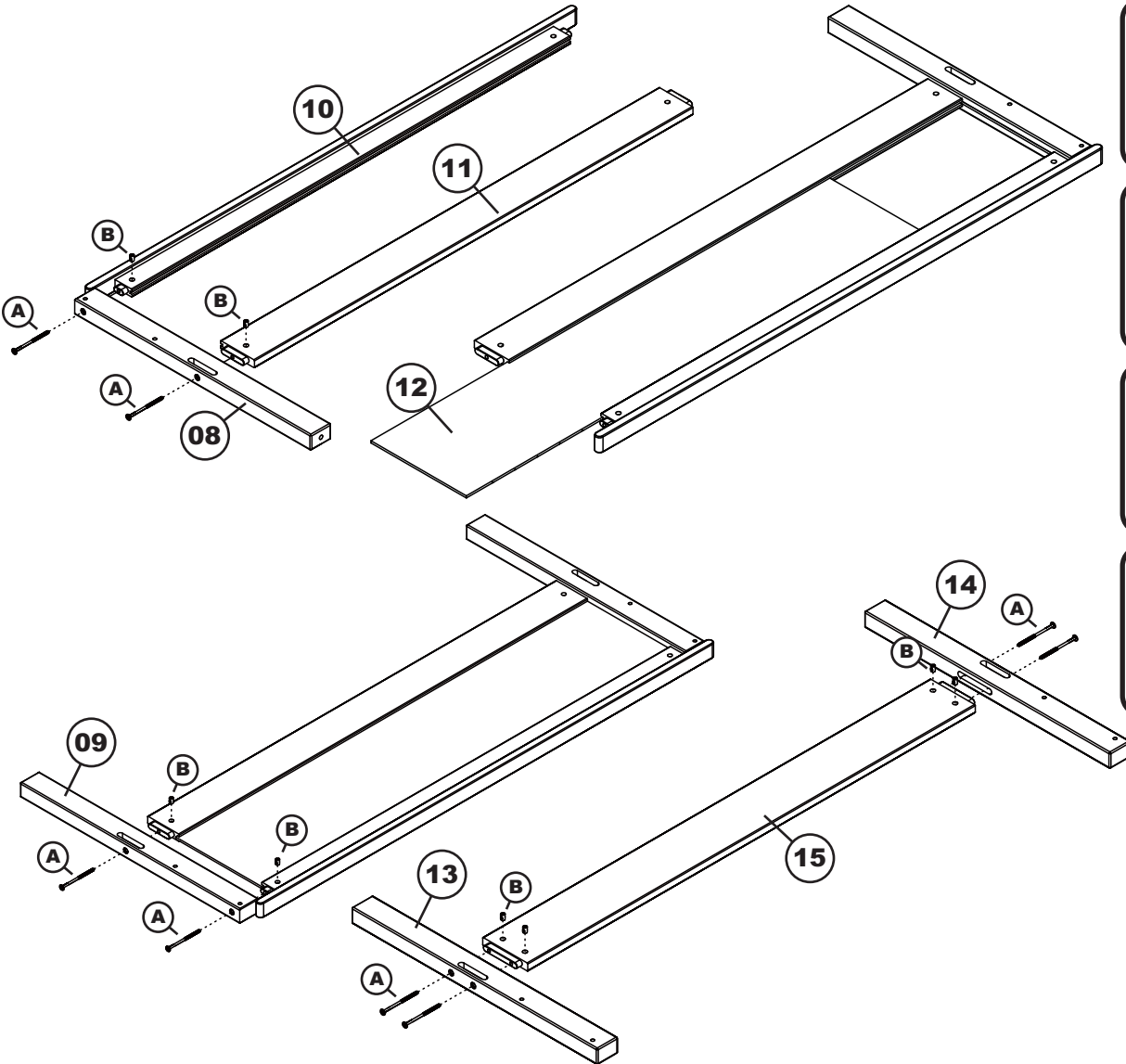

STEP 4 Attach upper right post (09) to the panel assemblies as shown below. Attach upper middle rail (15) to the U2 left post (13) and U2 right post (14) as shown below. Using JCB X 4" (A) and barrel nut (B) tighten with allen wrench (D).

STEP 5 Attach the short guard rail (18) to the left, right end cap (16)(17) as shown below, using JCB M6 X 1 1/2" (C), tighten with the allen wrench (D).
The short guardrail will be used in the next set of instructions.

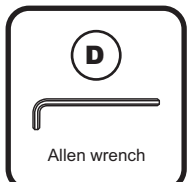
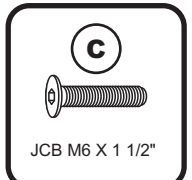
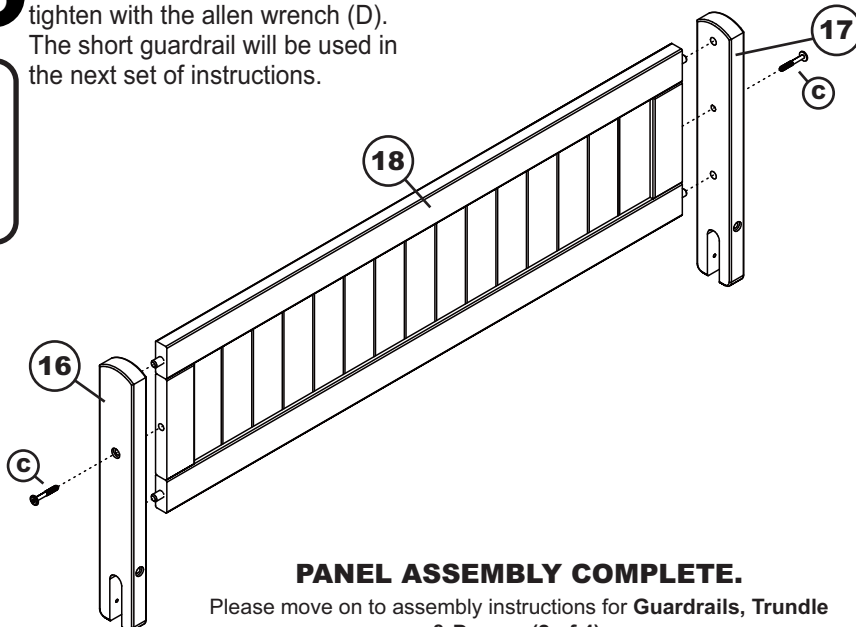

PANEL ASSEMBLY COMPLETE.

Please move on to assembly instructions for **Guardrails, Trundle & Drawer (2 of 4).**

ASSEMBLY INSTRUCTIONS

Thank you for choosing our new bunk bed.
This practical design offers the utmost in versatility.

Before assembling your staircase bookshelf bunk bed, please read through these instructions carefully. Familiarize yourself with the different parts.

Please note that you will require a phillips head screwdriver and an allen wrench.

ATTENTION! If you receive a damaged or defective item, please contact afifurnishings at customerservice@afifurnishings.com or 1-800-955-3726

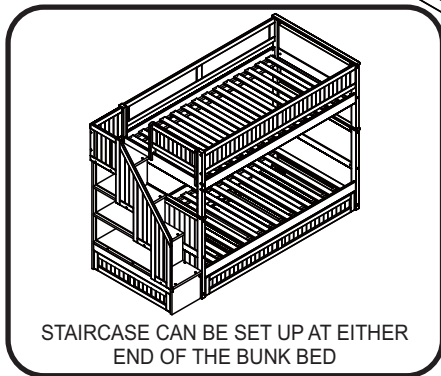
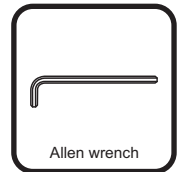
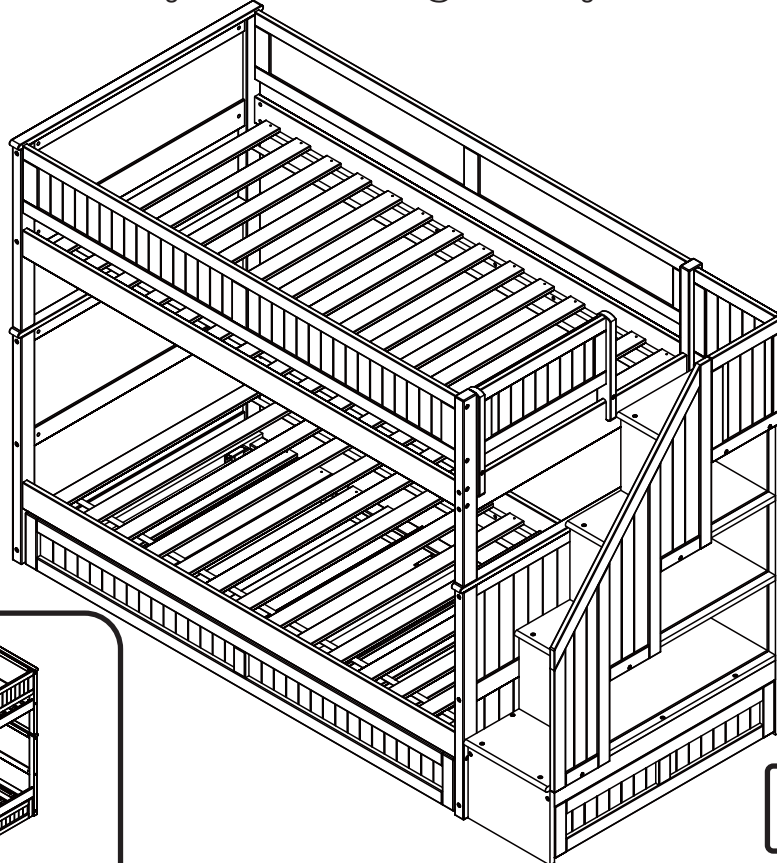



CODE	ITEM
BK-GRTD	B-6810X

PO:

HARDWARE

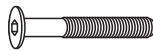
NOTE: WE INCLUDE SPARE HARDWARE IN CASE DAMAGE OCCURS DURING ASSEMBLY.

A  JCB M6 X 3 1/8" - 16 pcs
Spare - 1 pc

D  JCB M6 X 2 1/8" - 8 pcs
Spare - 1 pc

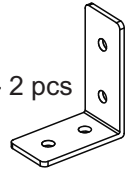
G  Trundle L Bracket - 2 pcs

B  Barrel nut - 16 pcs
Spare - 1 pc

E  JCB M6 X 1 1/4" - 11 pcs
Spare - 1 pc

H  JCB M6 X 5/8" - 8 pcs
Spare - 1 pc

C  Wood screw 1" - 4 pcs
Spare - 1 pc

F  Wood screw 1 1/4" - 2 pcs
Spare - 1 pc

I  Allen wrench - 1 pcs
Spare - 1 pc

PARTS LIST

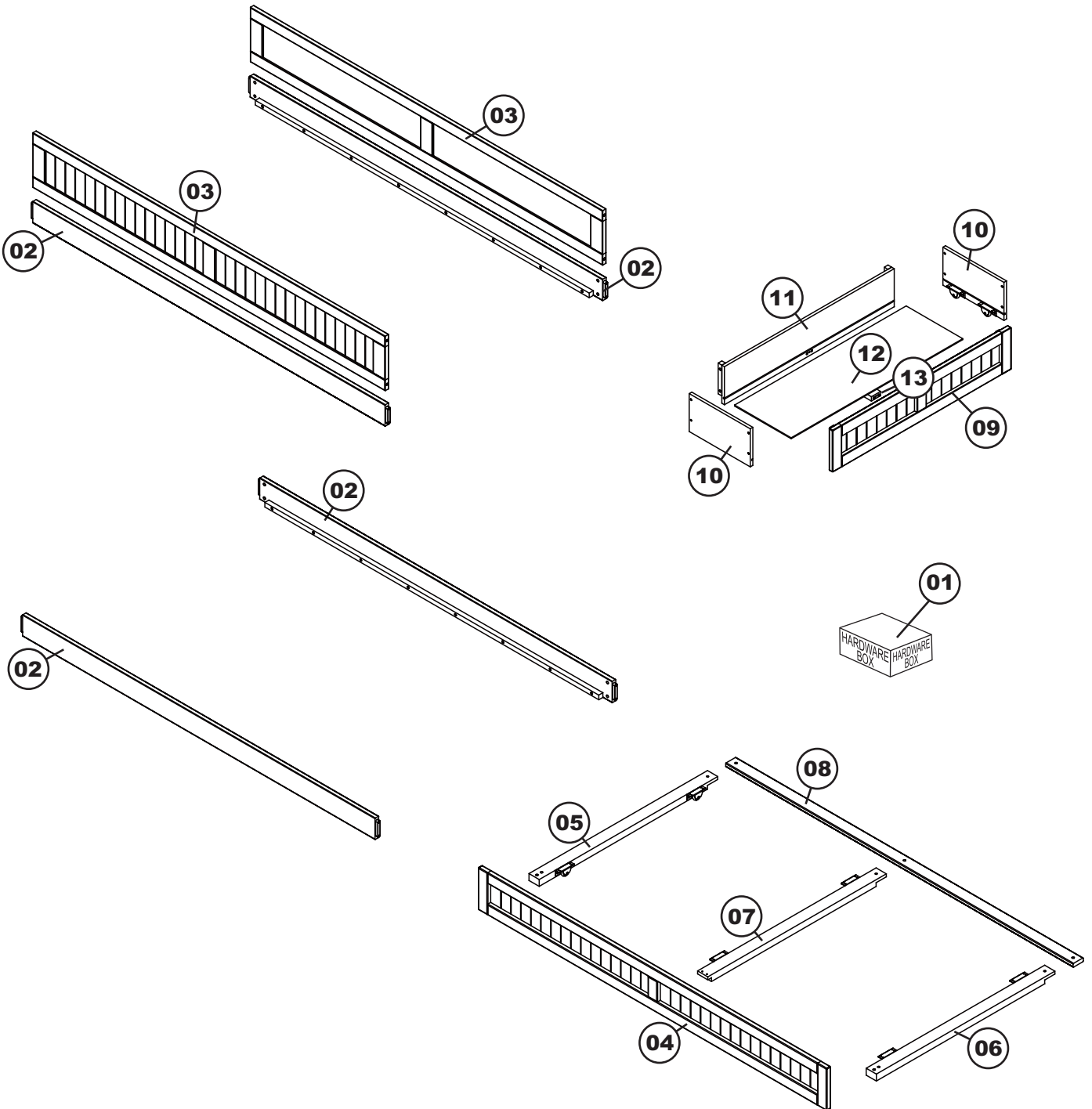

B-6810X

- | | | |
|-------------------|----------------|-------------------|
| 01 HARDWARE | 05 LEFT RAIL | 10 DRAWER SIDE |
| 02 SIDE RAIL | 06 RIGHT RAIL | 11 DRAWER BACK |
| 03 FULL GUARDRAIL | 07 MID RAIL | 12 DRAWER BOTTOM |
| 04 TRUNDLE FACE | 08 BACK RAIL | 13 DRAWER SUPPORT |
| | 09 DRAWER FACE | |

STEP 1 Attach the side rails (02) to the lower panels assemblies as shown below. Using JCB M6 X 3 1/8" (A) and barrel nut (B). Tighten with the Allen wrench (I).

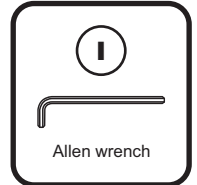
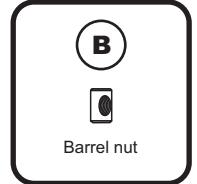
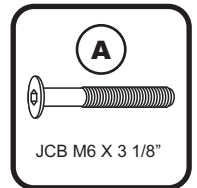
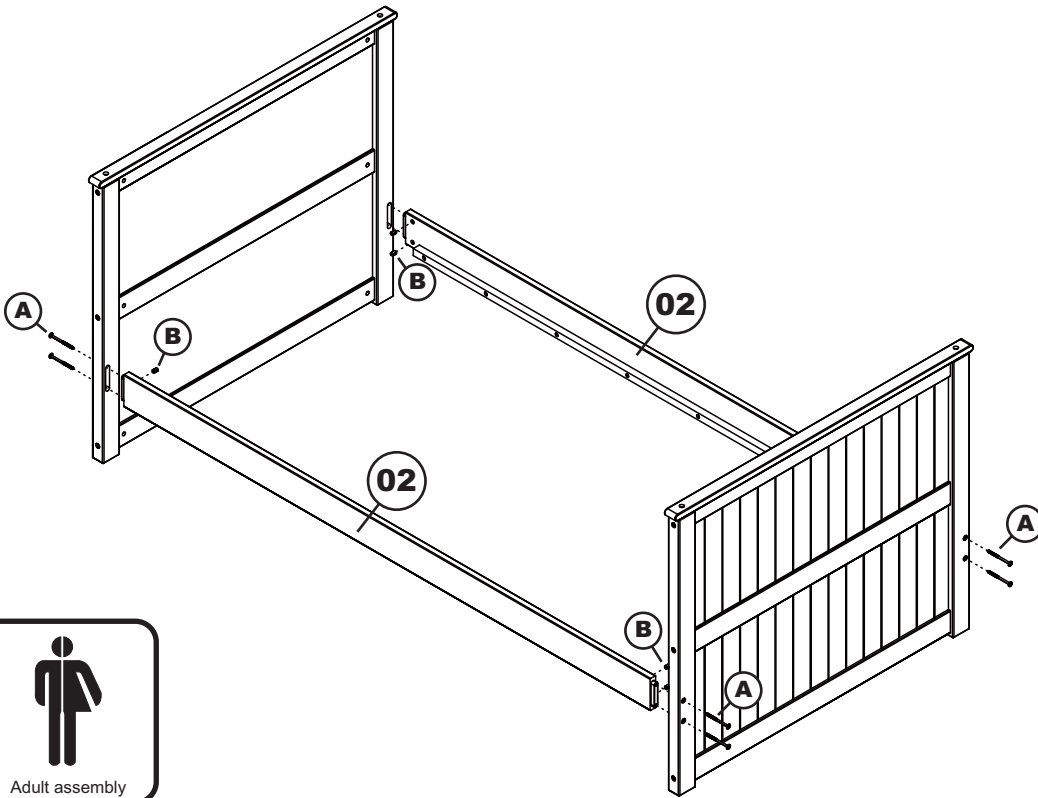

STEP 2 Attach the side rails (02) to the upper panels assemblies as shown below. Using JCB M6 X 3 1/8" (A) and barrel nut (B). Tighten with the Allen wrench (I).

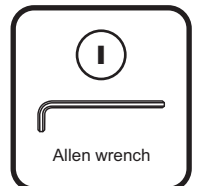
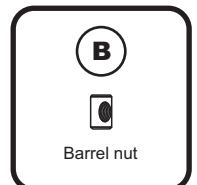
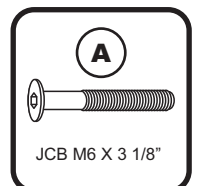
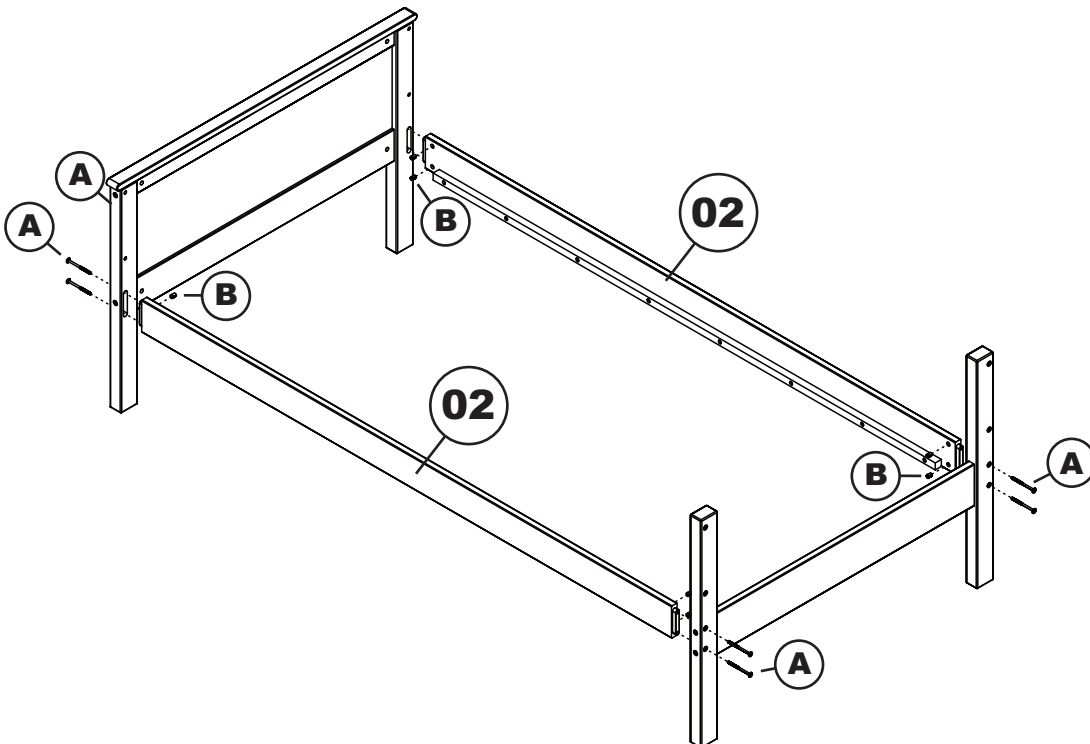

STEP 3 Attach short guardrail assemblies to the upper panel assemblies as shown below. Using wood screw (C) tighten with Phillips head screwdriver. (Customer supplied)

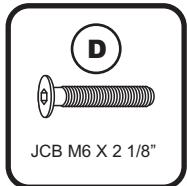
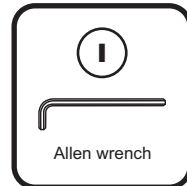
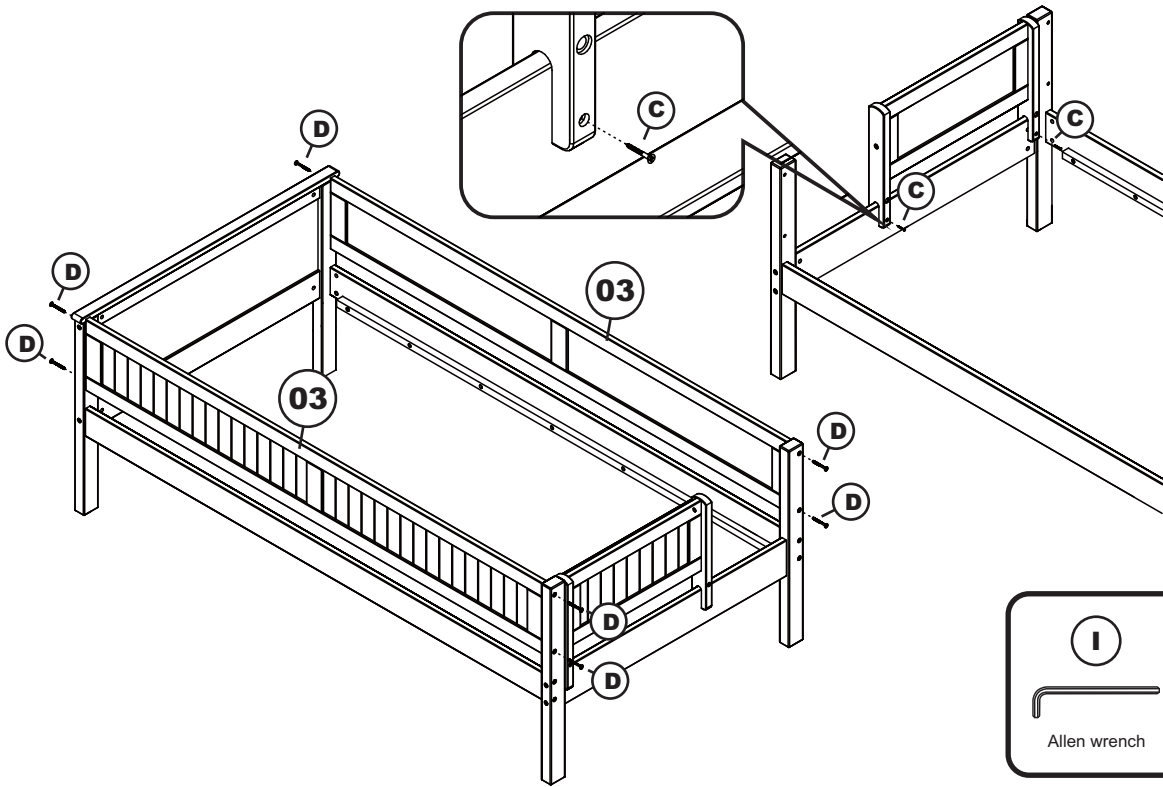

STEP 4 Attach full guardrail (03) to the upper panel assemblies as shown above. Using JCB M6 X 2 1/8"(D) tighten with allen wrench (I).

STEP 5 Lay the drawer face (09) on smooth, flat surface so the drawer bottom (12) groove is facing upwards. Attach the drawer sides (10) to drawer face (09) using JCB M6 X 1 1/4" (E). Align groove inside drawer side with groove in drawer face. Tighten with Allen wrench (I).

DRAWER ASSEMBLY

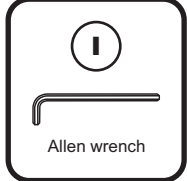
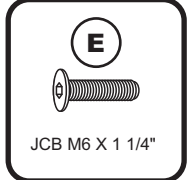
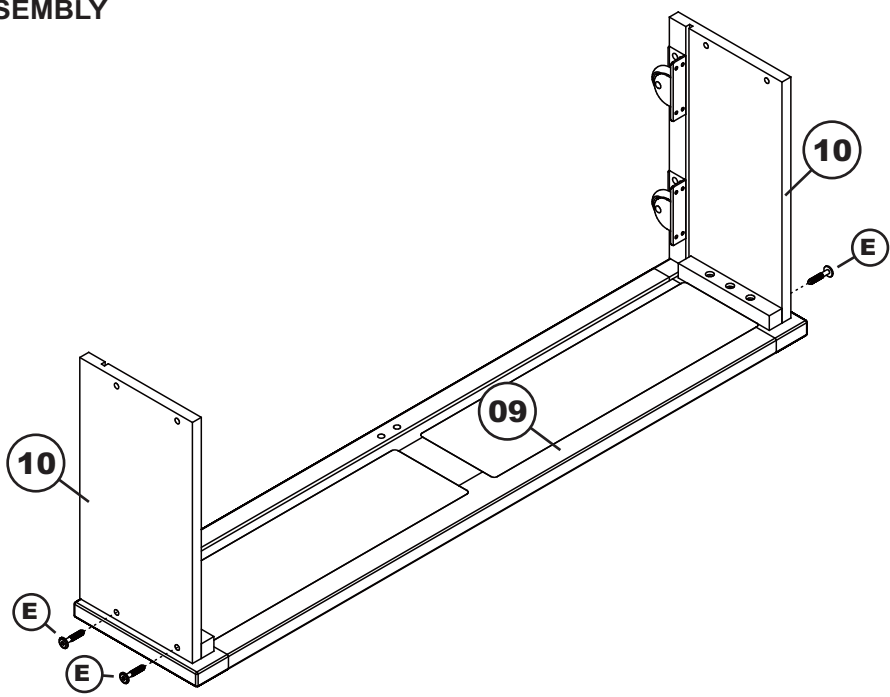

STEP 6

Guide the drawer bottom (12) in carefully so that it won't jump out of its grooves. Be sure it fits fully into its groove at the bottom (in the drawer face) before fitting the drawer back. Install the drawer support (13) so that the wooden dowels fit into the locator holes as shown below.

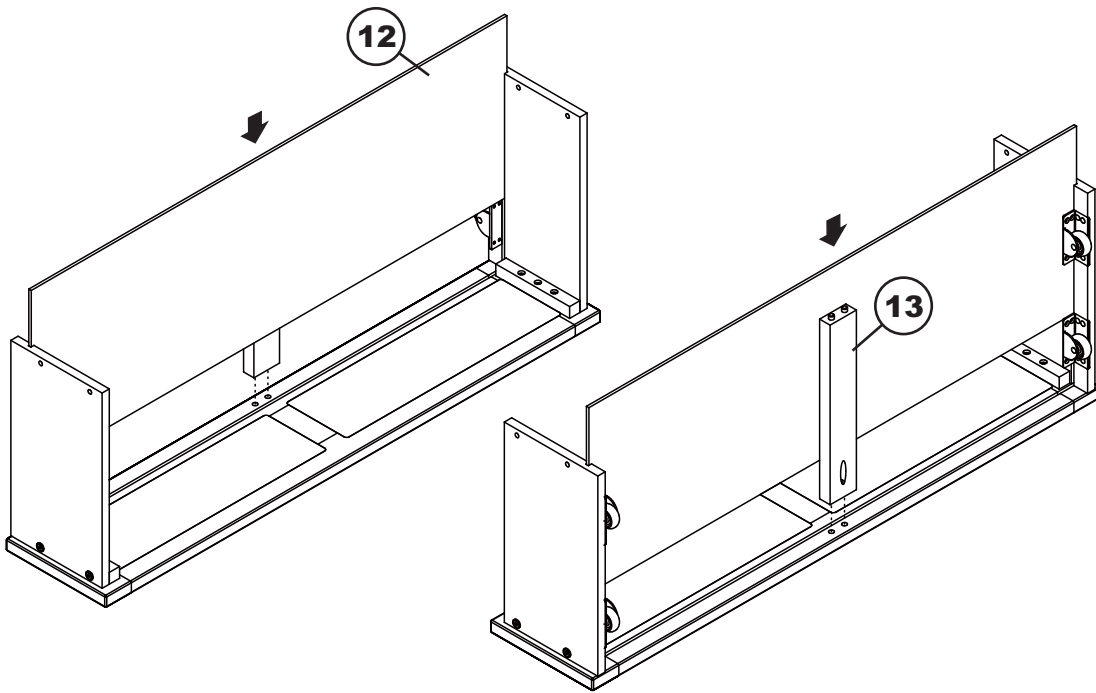

STEP 7

Attach drawer back (11) to bed drawer assemblies as shown. Use JCB M6 X 1 1/4"(E). Tighten with Allen wrench (I). Using wood screw (F) tighten with Phillips head screwdriver. (Customer supplied)

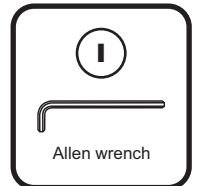
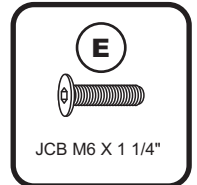
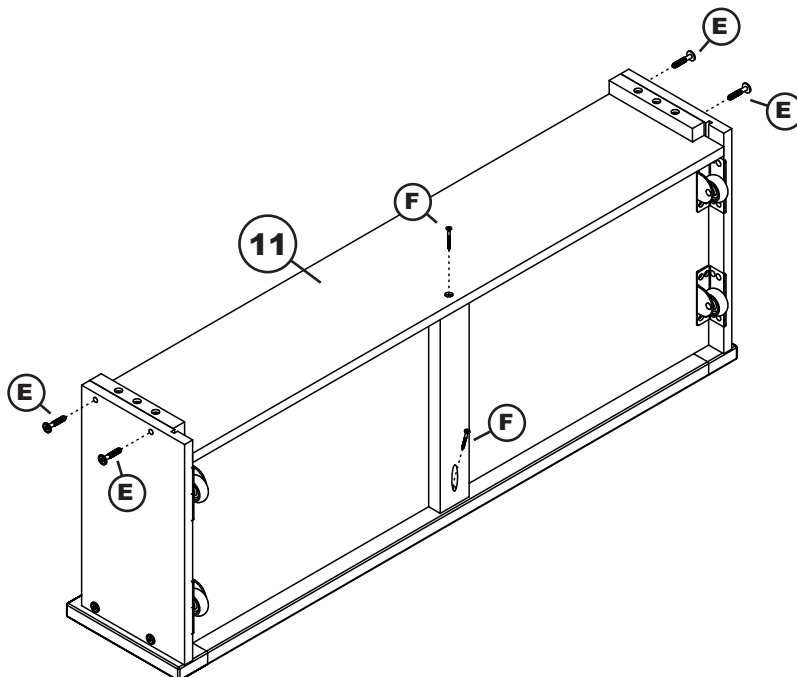

STEP 8

Attach trundle L bracket (G) to the left and right rail (05) (06). Using JCB M6 X 5/8"(H). Tighten with allen wrench (I).

TRUNDLE BED ASSEMBLY

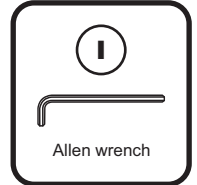
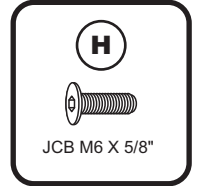
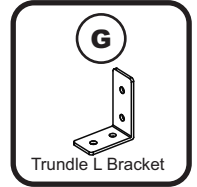
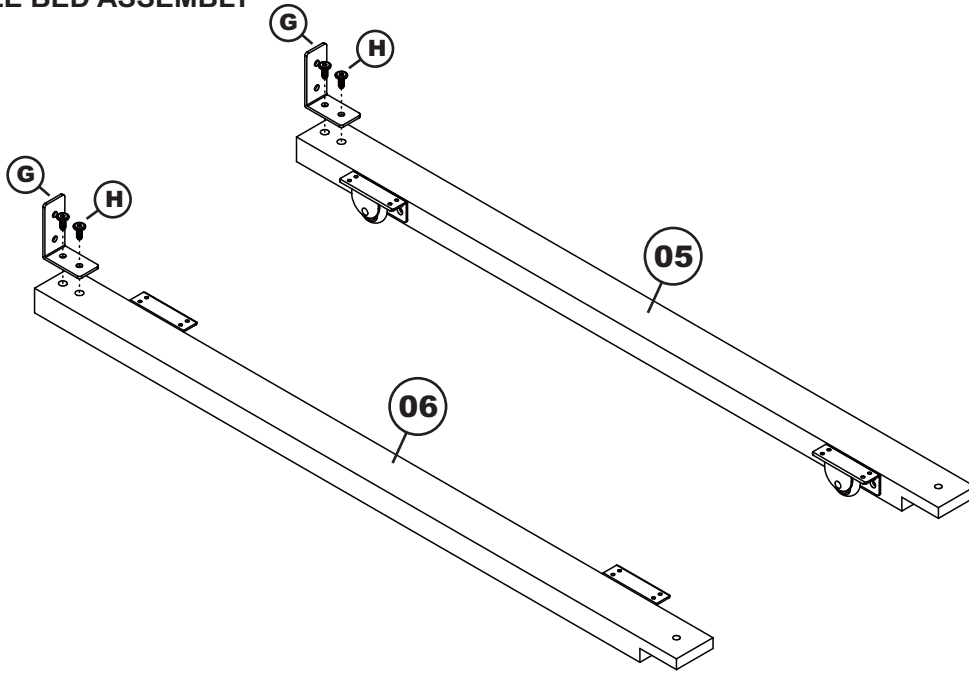

STEP 9

Attach the left, right and mid rail (05)(06)(07) to the trundle face (04) and back rail (08) as shown, using JCB M6 X 5/8" (H) and JCB M6 X 1 1/4" (E). Tighten with the Allen wrench (I). Using wood screw (C) tighten with Phillips head screwdriver. (Customer supplied)

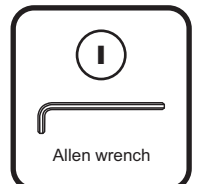
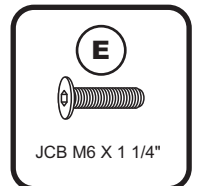
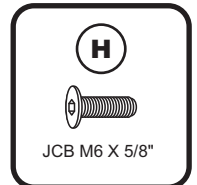
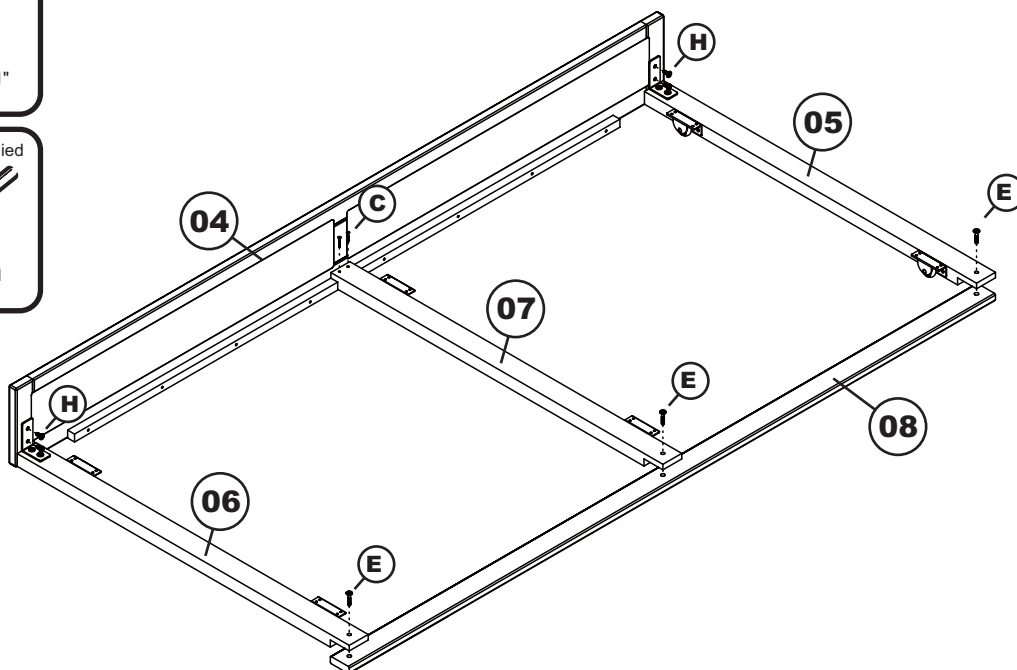

**GUARDRAILS, TRUNDLE & DRAWER
ASSEMBLY COMPLETE.**

Please move on to assembly instructions for Slat Kit (3 of 4).

ASSEMBLY INSTRUCTION

FULL>FULL

Before assembling your bed slat kit, please read through these instructions carefully and familiarize yourself with the different parts.

Please note that you will require a Phillips screwdriver.

ATTENTION! If you receive a damaged or defective item, please contact affurnishings at customerservice@afifurnishings.com or 1-800-955-3726



PARTS LIST

E-62331

- 01 HARDWARE
- 02 SLAT KIT FULL
- 03 CENTER SUPPORT
- 04 SLAT KIT TRUNDLE

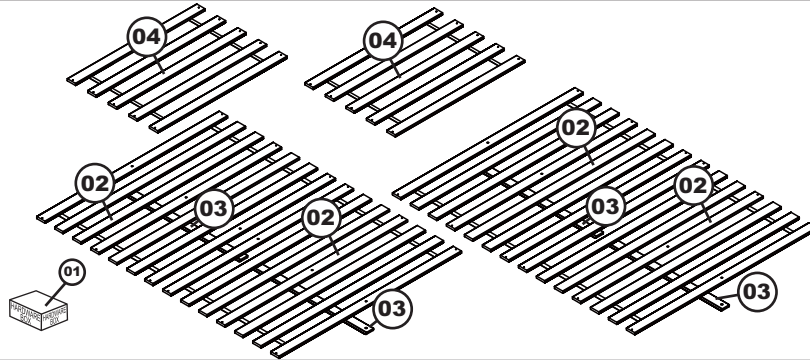

HARDWARE

- A** 1 1/4" JCB - 12 pcs
Spare - 1 pc
- B** Cap Nut - 12 pcs
- C** 1 1/4" Wood screw - 44 pcs
Spare - 2 pcs
- D** Metal pins - 4 pcs
- E** Allen wrench - 1 pc

CODE	ITEM
SL-BK	E-62331

NOTE: WE INCLUDE SPARE HARDWARE IN CASE DAMAGE OCCURS DURING ASSEMBLY.

Step 1 Assemble bunk bed according to assembly instructions.

Step 2 Lay the slat kit full (02) onto the bed as shown. Attach center support (03) to slat kit full using JCB M6 X 1 1/4" (A) and cap nut (B), tighten with the Allen wrench (E). Repeat for section 2. Using wood screw (C) tighten with Phillips head screwdriver. (Customer supplied)



Adult assembly

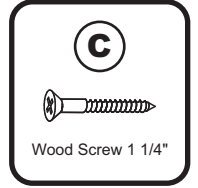
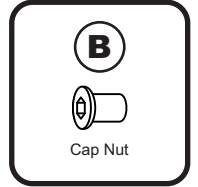
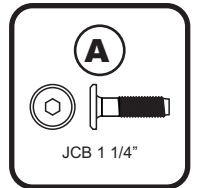
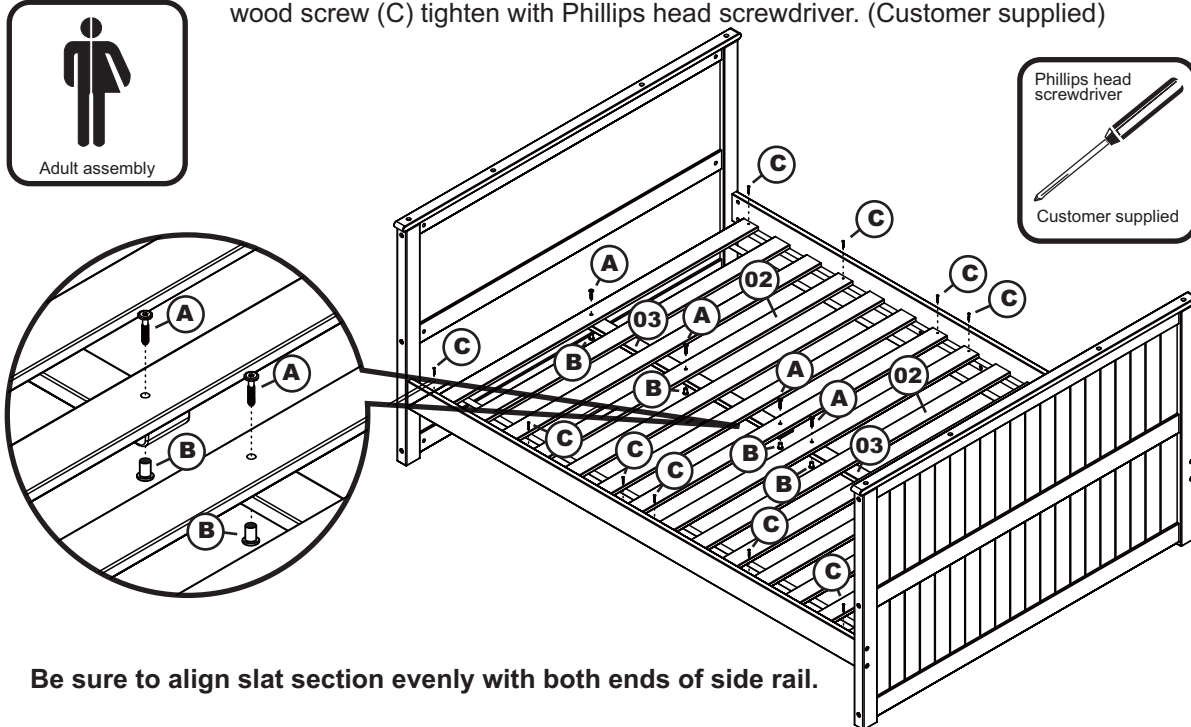

Be sure to align slat section evenly with both ends of side rail.

FULL>FULL

Step 3

Lay the slat kit full (02) onto the bed as shown. Attach center support (03) to slat kit full using JCB M6 X 1 1/4" (A) and cap nut (B), tighten with the Allen wrench (E). Repeat for section 2. Using wood screw (C) tighten with Phillips head screwdriver. (Customer supplied)

NOTE: WEBBING MUST FACE UP

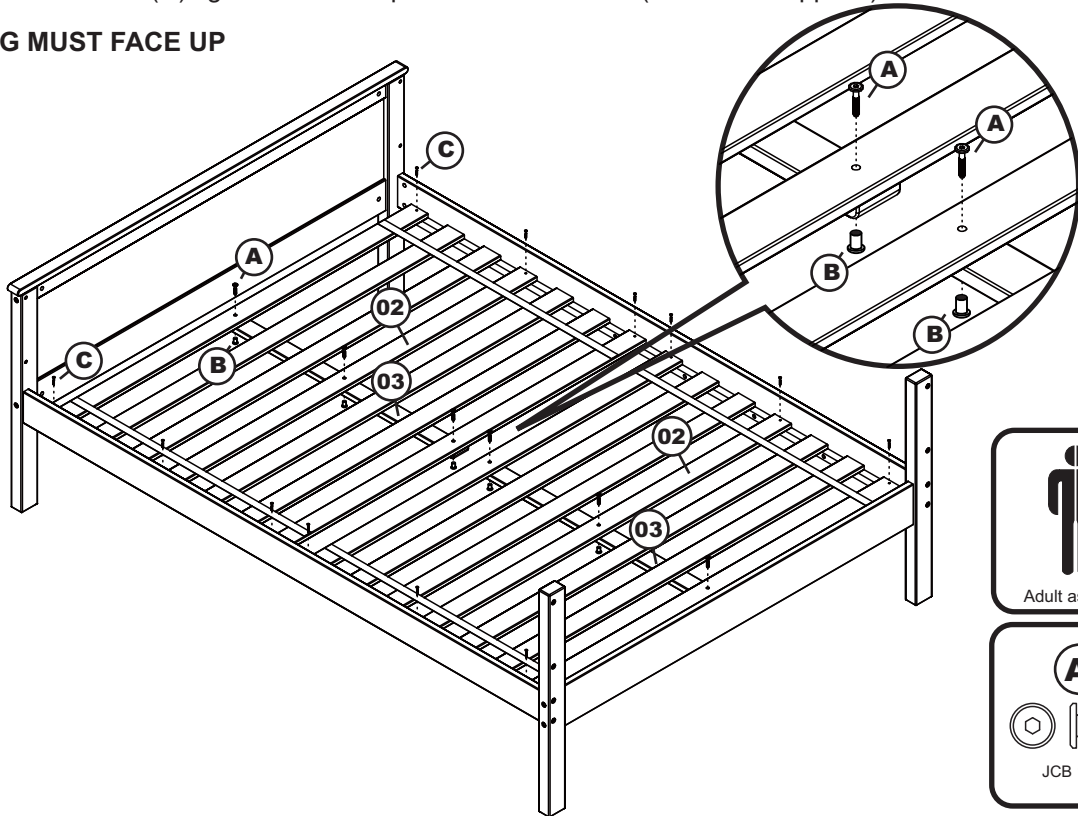

Adult assembly

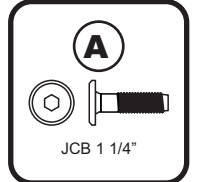

JCB 1 1/4"

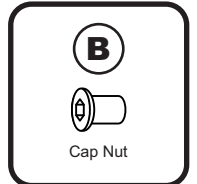

Cap Nut



Wood Screw 1 1/4"



Phillips head
screwdriver

Customer supplied

Step 4

Lay the slat kit trundle (04) onto the trundle bed as shown. Screw slat section using wood screw (C). Tighten with Phillips screwdriver. (Customer supplied) Be sure the space between slats is even.

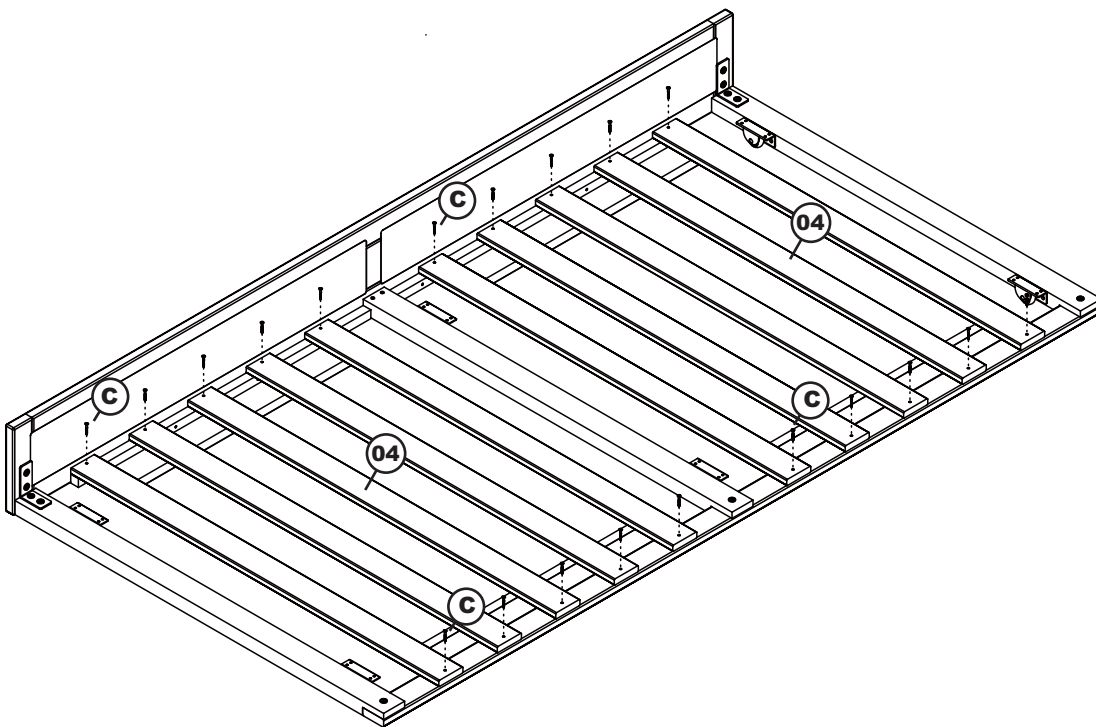

Step 5

Insert metal pins (D) into the holes on top of the lower panels. Lift the upper panels onto the lower panels as shown, and fit the metal pins into the holes in the bottom of the upper panel legs.

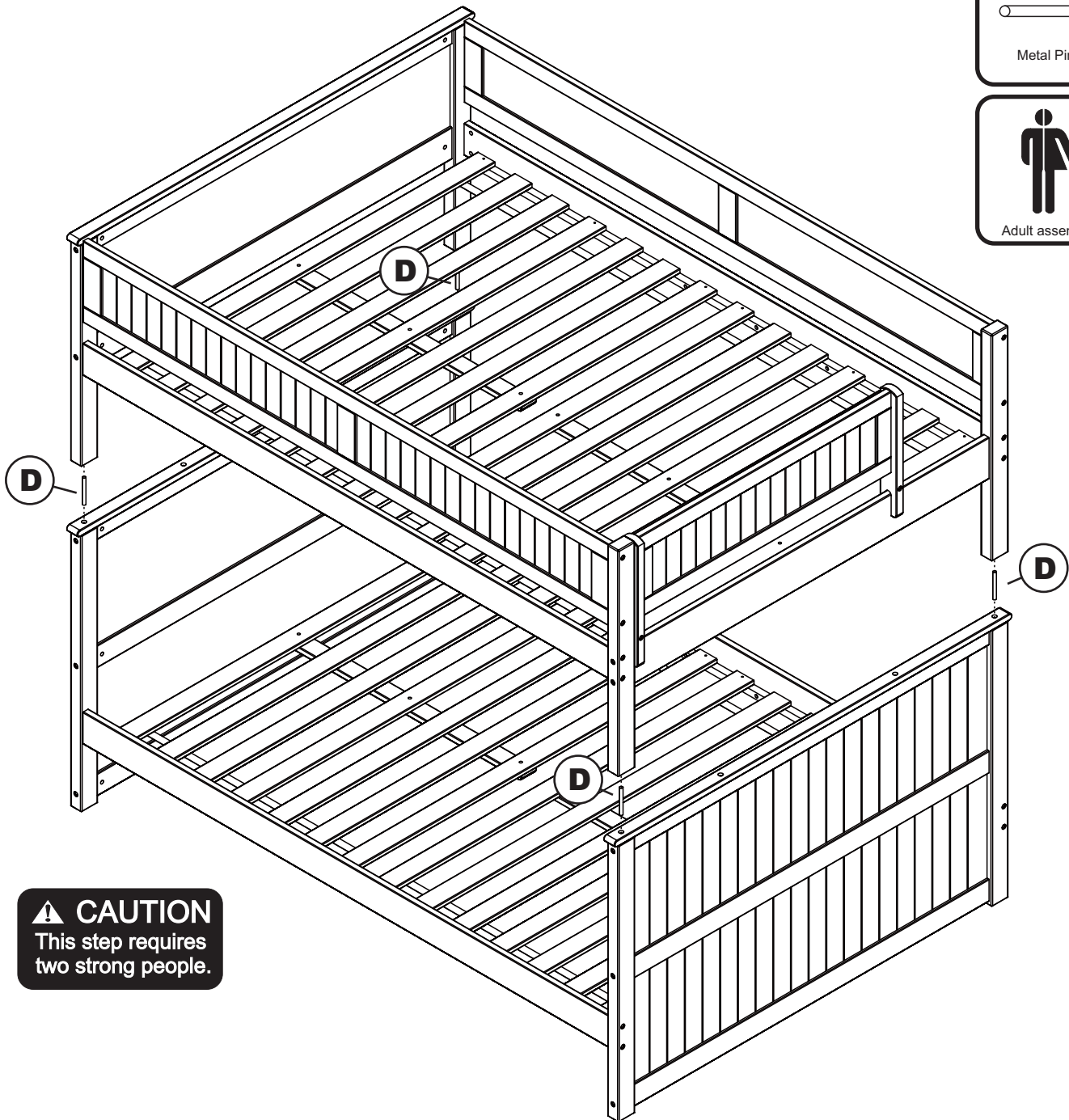
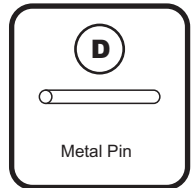

CAUTION
This step requires
two strong people.

SLAT KIT ASSEMBLY COMPLETE.

Please move on to assembly instructions for **Staircase Bookshelf**
(4 of 4).

ASSEMBLY INSTRUCTIONS

Thank you for choosing our new bunk bed.
This practical design offers the utmost in versatility.

Before assembling your staircase bookshelf bunk bed, please read through these instructions carefully. Familiarize yourself with the different parts.

Please note that you will require a phillips head screwdriver and an allen wrench.

ATTENTION! If you receive a damaged or defective item, please contact afifurnishings at customerservice@afifurnishings.com or 1-800-955-3726

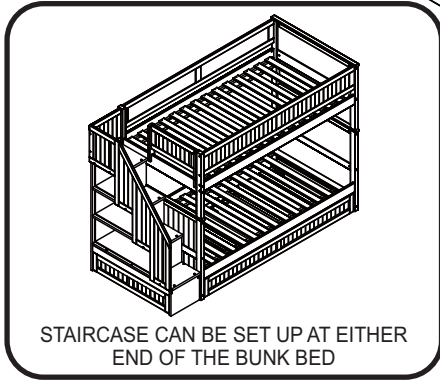
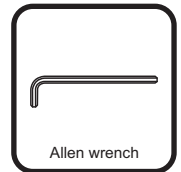
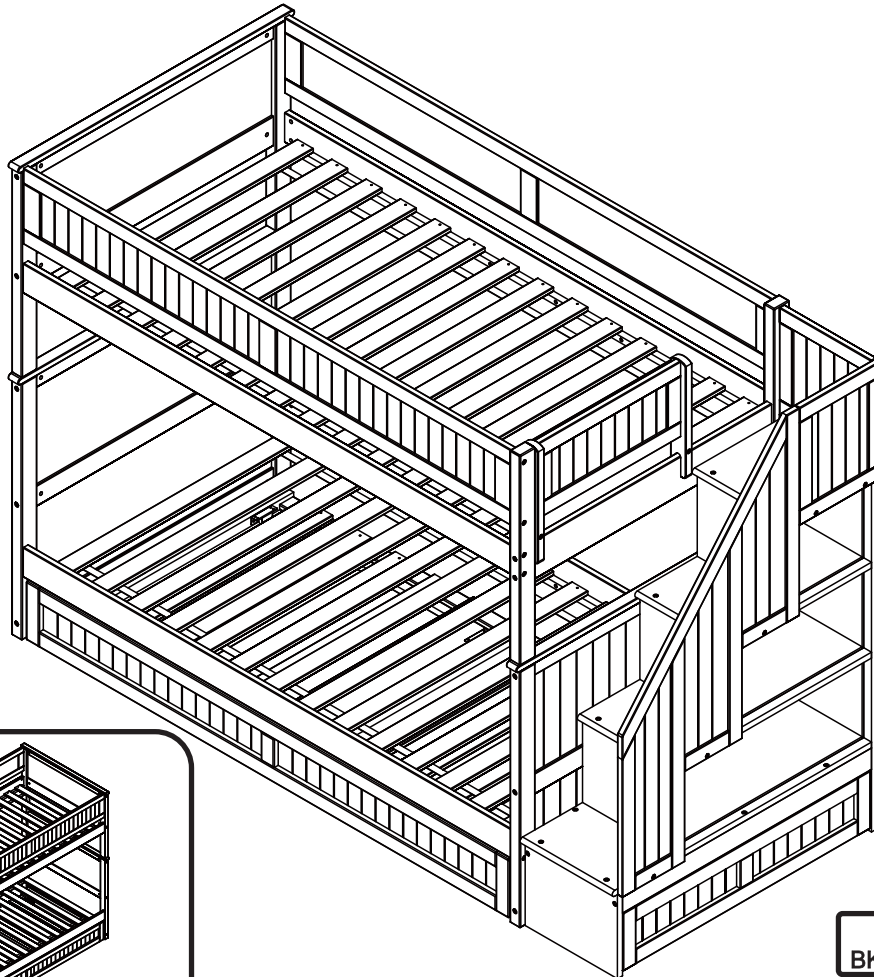

CODE	ITEM
BK-SCGR	B-6800X

PO: _____

HARDWARE

NOTE: WE INCLUDE SPARE HARDWARE IN CASE DAMAGE OCCURS DURING ASSEMBLY.

A  Wooden dowels - 26 pcs
Spare - 2 pcs

B  JCB M6 X 1 3/8" - 39 pcs
Spare - 1 pcs

C  Flat bracket - 4 pcs

D  Wood screw 1/2" - 20 pcs
Spare - 2 pcs

E  L bracket - 6 pcs

F  Allen wrench - 1 pcs
Spare - 1 pcs

PARTS LIST

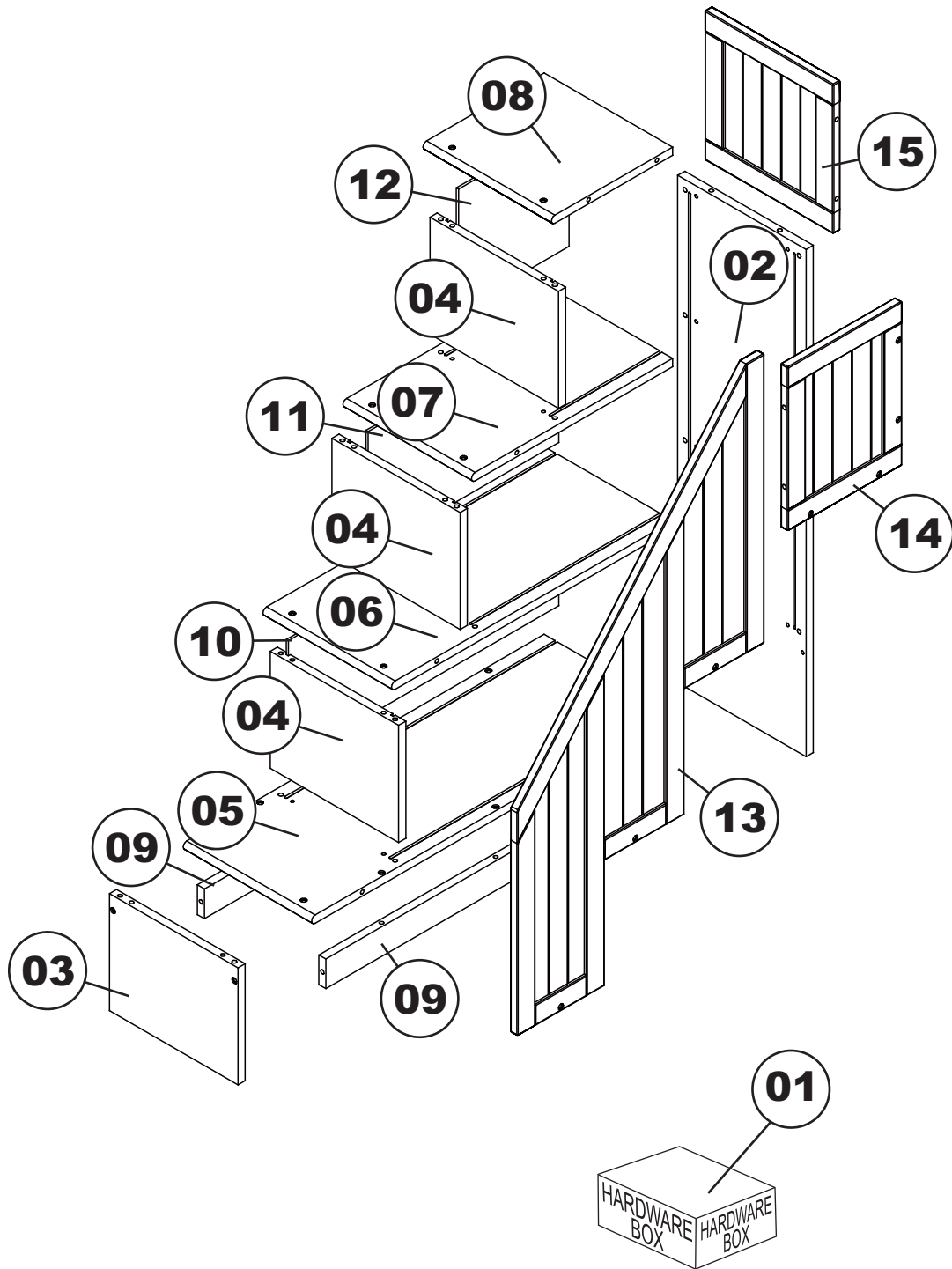

B-6800X

- | | | | | | |
|----|-----------------|----|-----------------|----|-----------------|
| 01 | HARDWARE | 06 | BS 1 TOP PANEL | 11 | BS 2 BACK PANEL |
| 02 | LONG SIDE PANEL | 07 | BS 2 TOP PANEL | 12 | BS 3 BACK PANEL |
| 03 | FS SIDE PANEL | 08 | BS 3 TOP PANEL | 13 | HAND GUARDRAIL |
| 04 | BS SIDE PANEL | 09 | BS BOTTOM RAIL | 14 | SIDE GUARDRAIL |
| 05 | FS TOP PANEL | 10 | BS 1 BACK PANEL | 15 | BACK GUARDRAIL |

STEP 1 Insert wooden dowel (A) into the locator holes.

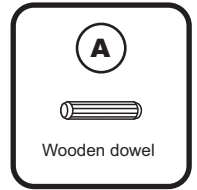
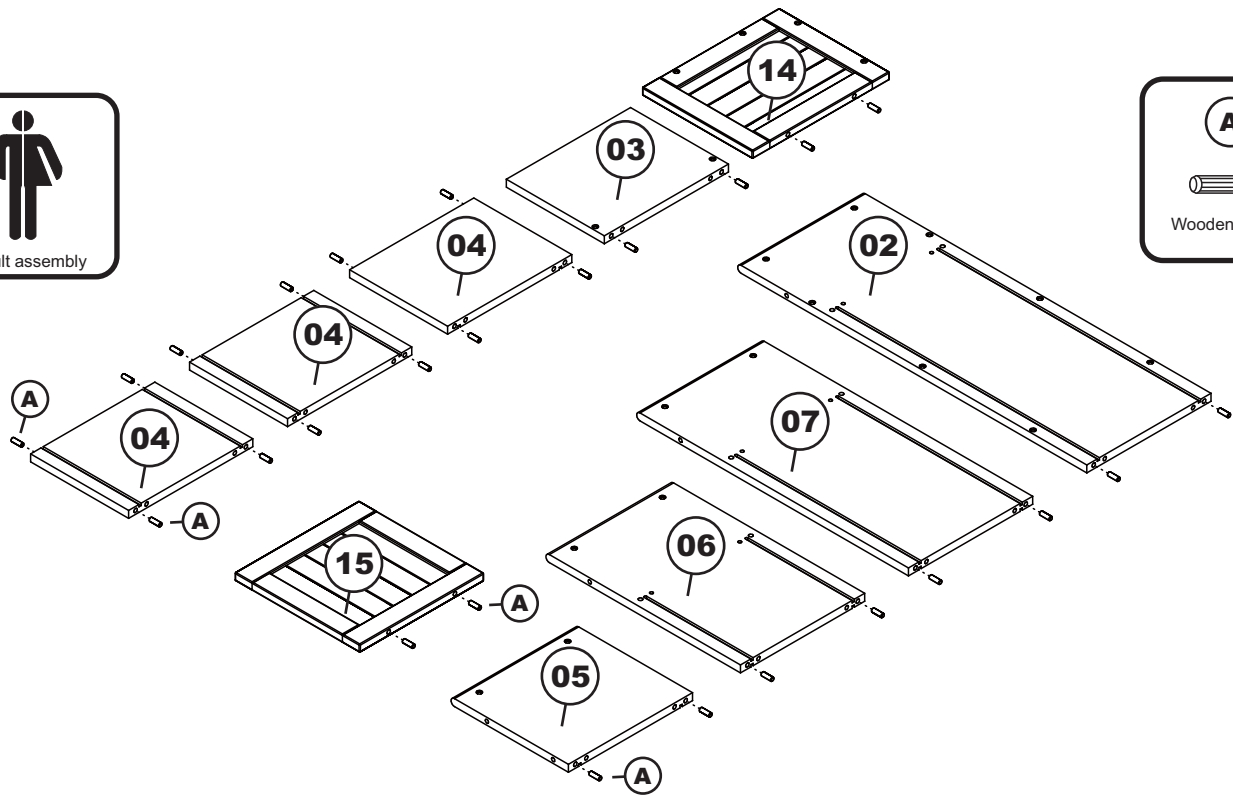

STEP 2 Attach BS bottom rail (09) to the floor storage side panel (03) as shown below. Using JCB M6 X 1 3/8" (B). Tighten with allen wrench (F), but don't fully tighten this yet.
Attach floor storage top panel (05) to the floor storage side panel assemblies. Using JCB M6 X 1 3/8" (B). Tighten with allen wrench (F).

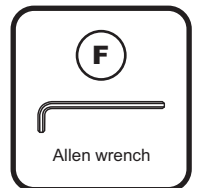
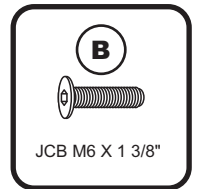
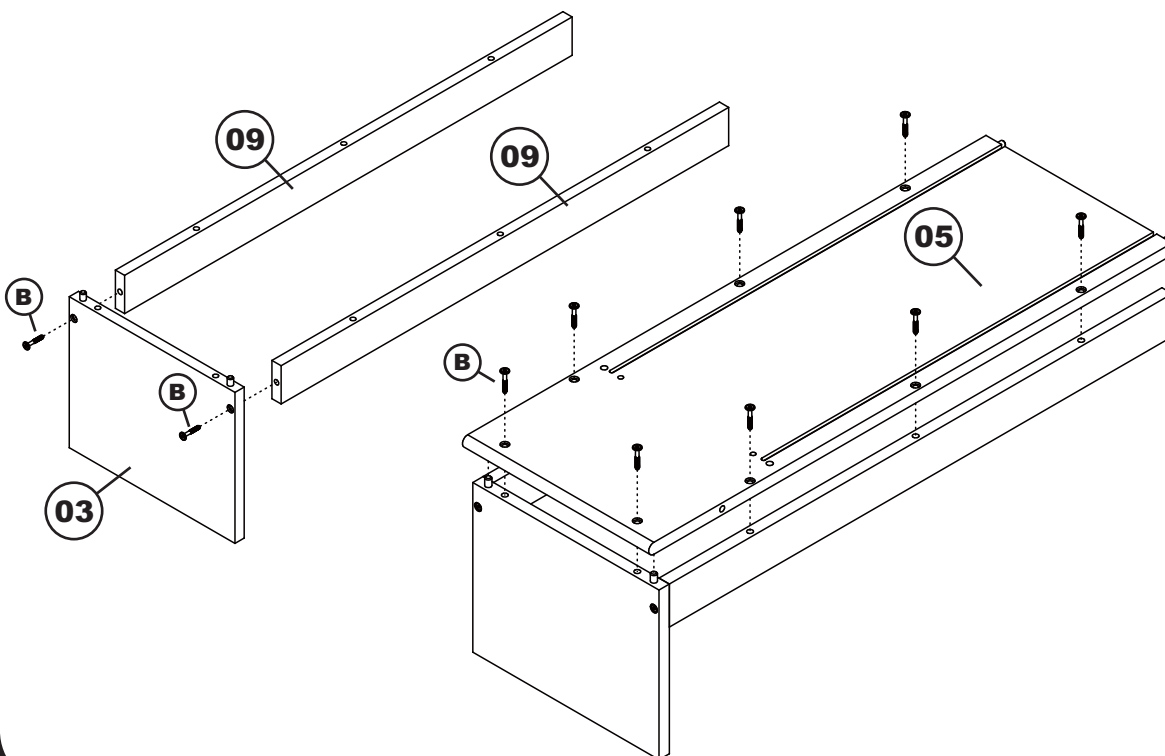

STEP 3

Attach long side panel (02) to the floor storage side panel assemblies as shown below. Using JCB M6 X 1 3/8" (B). Tighten with allen wrench (F). Attach BS side panel (04) to the floor storage side panel assemblies using JCB M6 X 1 3/8" (B). But don't fully tighten these yet. Leave them a bit loose to make fitting the back panel easier.

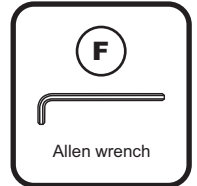
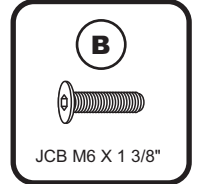
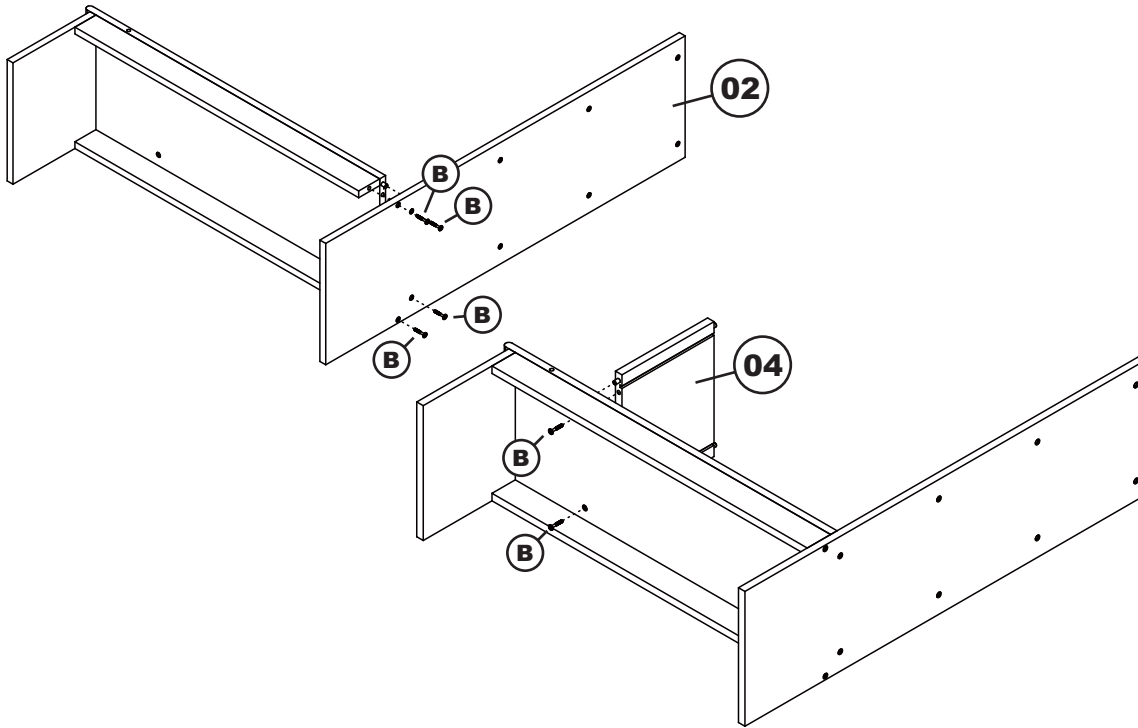

STEP 4

Guide BS 1 back panel (10) in carefully so that it won't jump out of its grooves. Be sure it fits fully into the groove at the bottom (in floor storage top panel). Attach BS 1 top panel (06) to the BS side panel (04). Using JCB M6 X 1 3/8" (B) tighten with allen wrench (F).

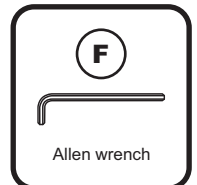
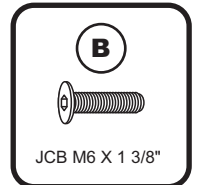
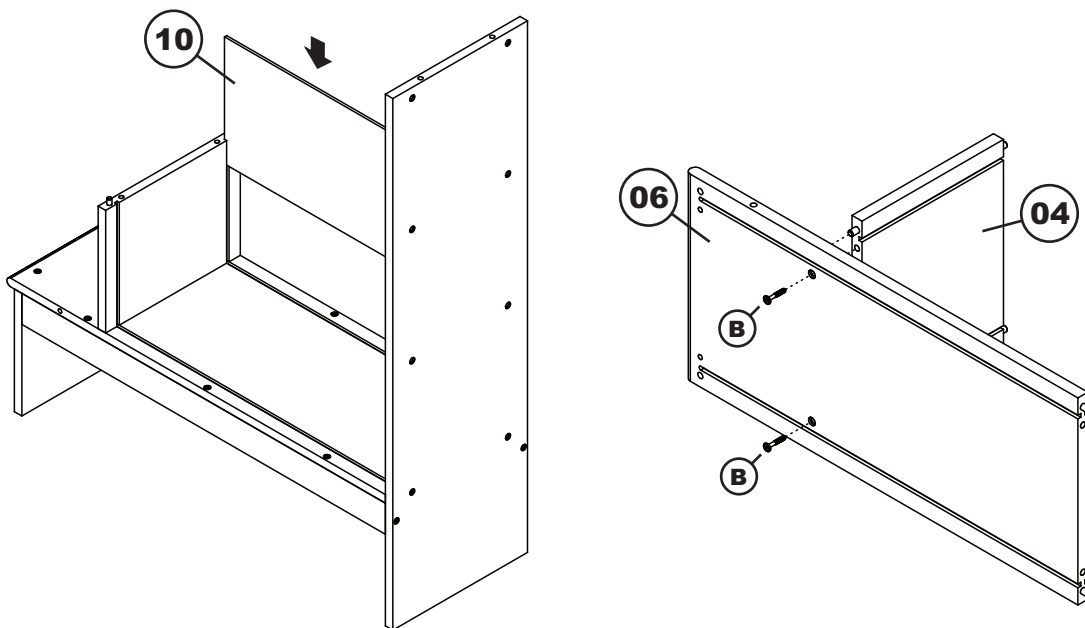

STEP 5

Attach BS 1 top panel assemblies (06) as shown below using JCB M6 X 1 3/8" (B). Tighten with Allen wrench (F). Install BS 2 back panel (11). Attach BS 2 top panel (07) to the BS side panel (04) as shown below. Using JCB M6 X 1 3/8" (B). Tighten with allen wrench (F).

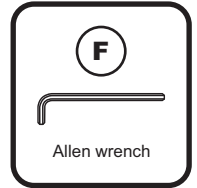
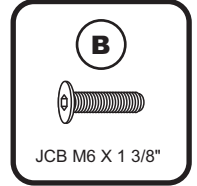
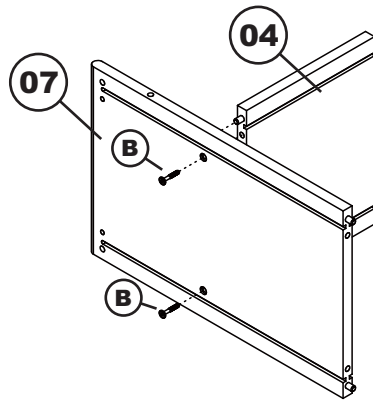
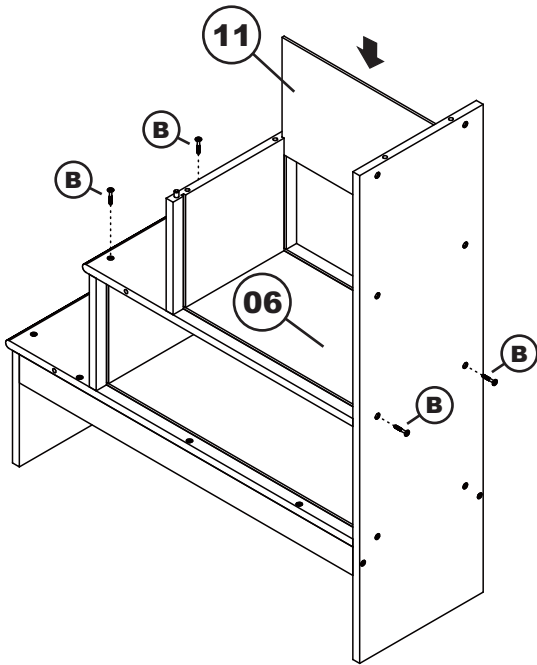

STEP 6

Attach BS 2 top panel assemblies (07) as shown below using JCB M6 X 1 3/8"(B). Install BS 3 back panel (12) Tighten with Allen wrench (F). Attach BS 3 top panel (08) as shown below. Using JCB M6 X 1 3/8" (B). Tighten with allen wrench (F).

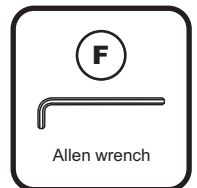
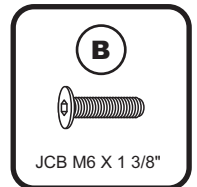
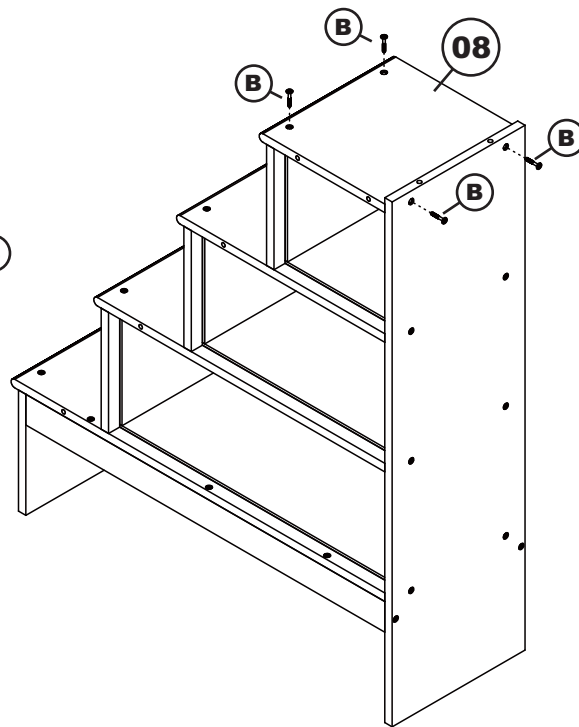
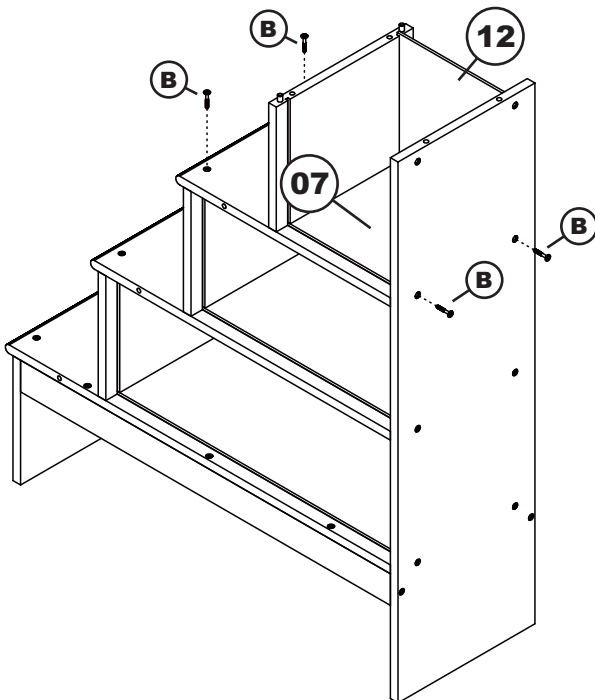

STEP 7

Attach back guardrail (15) to the staircase bookshelf assemblies. Using flat bracket (C) and wood screw (D). Tighten with Phillips head screwdriver. (Customer supplied)

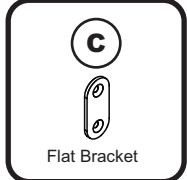
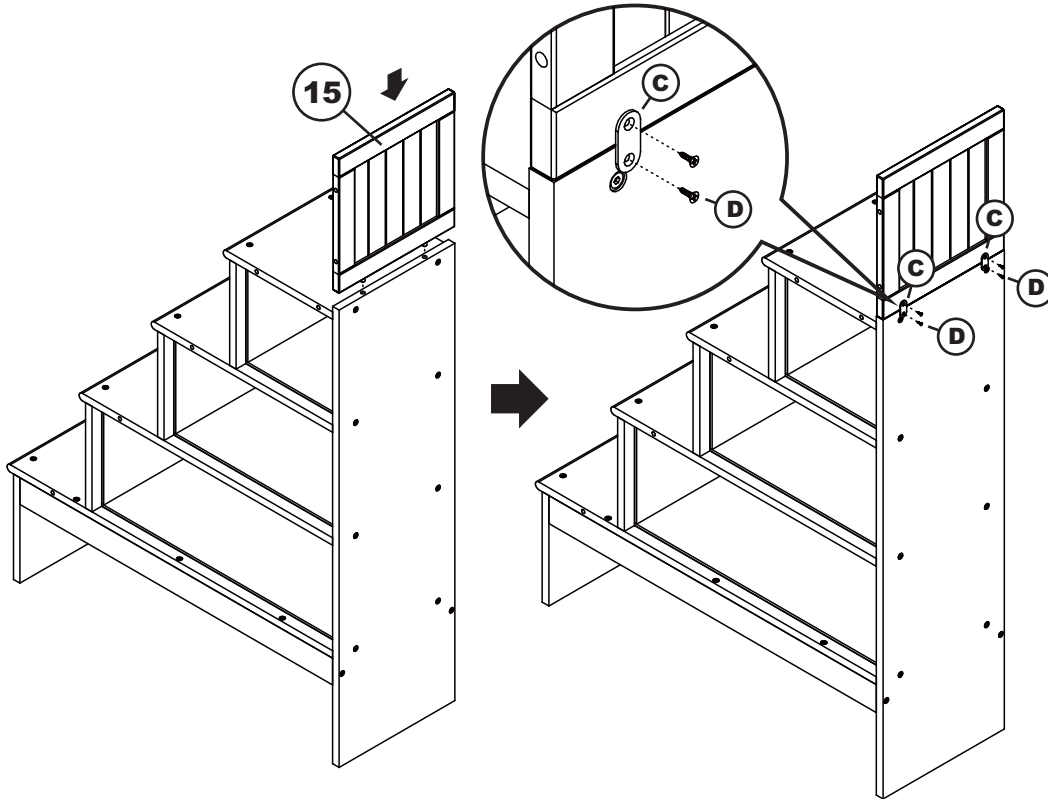

STEP 8

Attach side guard rail (14) to the staircase bookshelf assemblies. Using JCB M6 X 1 3/8" (B) tighten with allen wrench (F). Attach hand guardrail (13) onto side guardrail and use JCB M6 X 1 3/8" (B). Using flat bracket (C) and wood screw (D) tighten with Phillips head screwdriver. (Customer supplied). Recheck that all JCB and screws are tight.

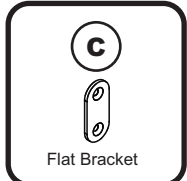
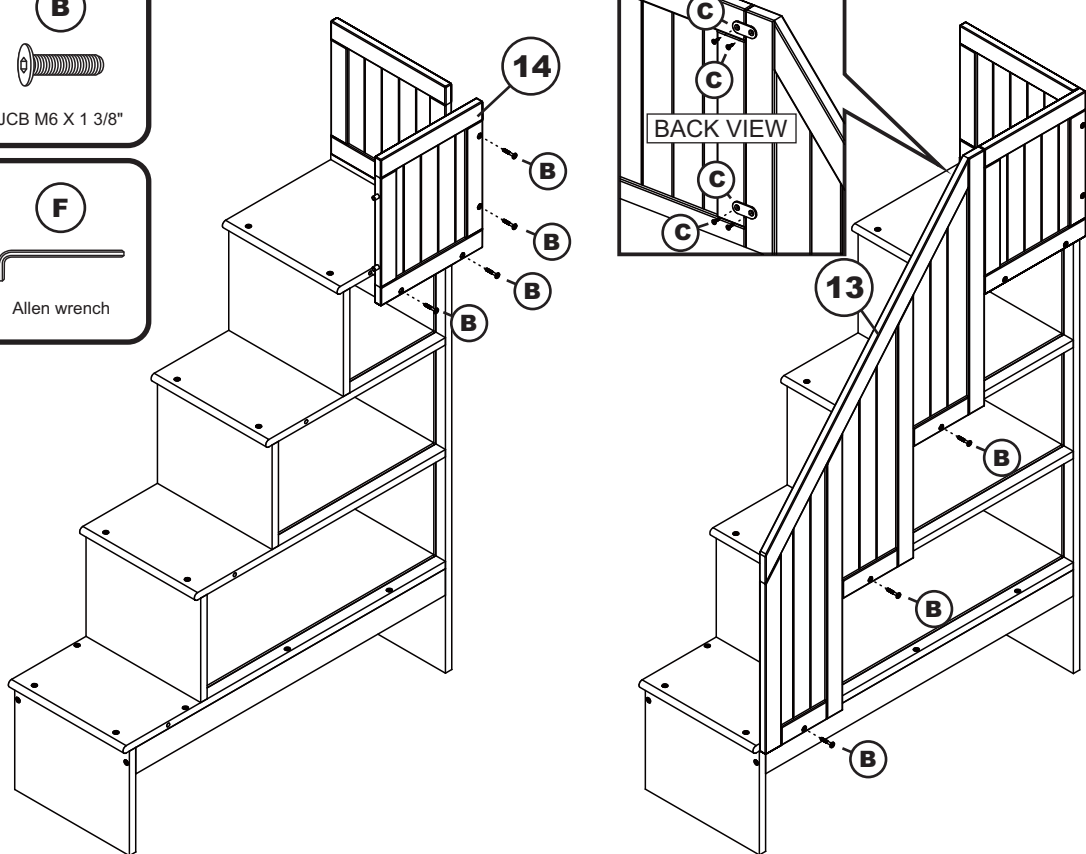
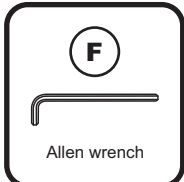
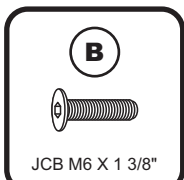

STEP 9

Move the bunk bed and staircase bookshelf assemblies where you want to place them in the room. Attach staircase bookshelf assembly to the bunk bed assembly as shown below. Fix L bracket (E) to upper, lower bunk panel using wood screws (D) as shown. Tighten with Phillips head screw driver. (Customer supplied)

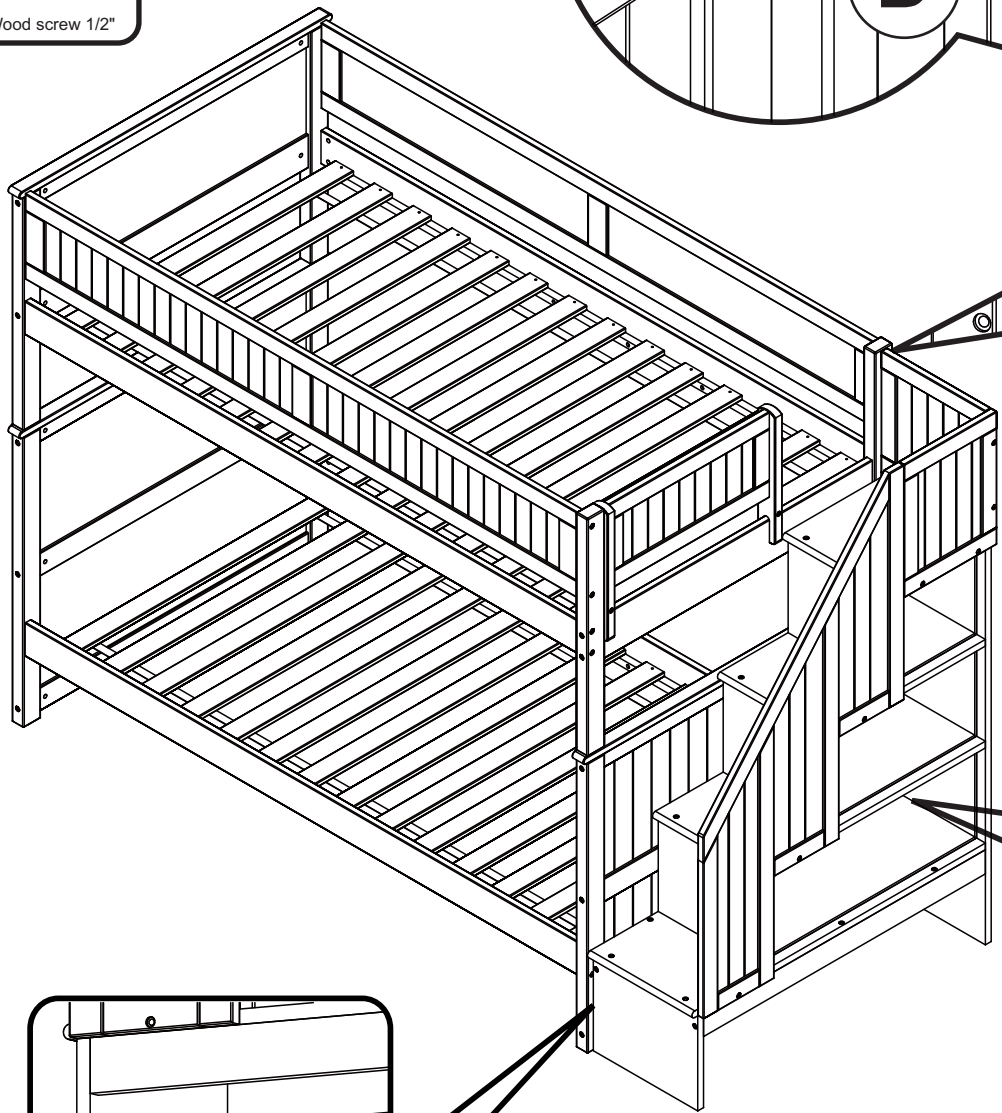
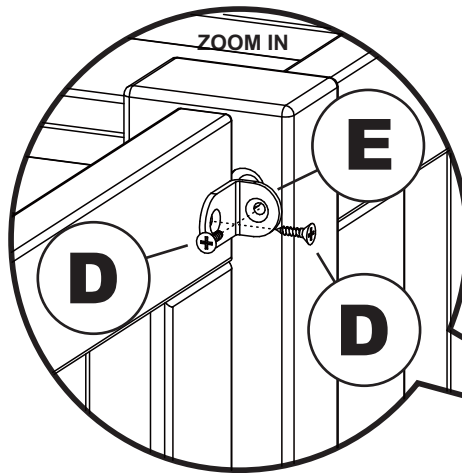
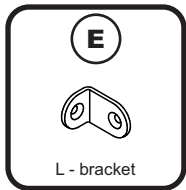

BACK TOP VIEW

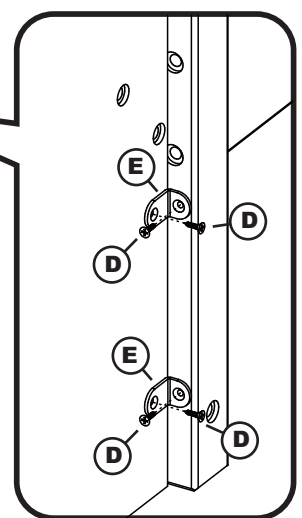

BACK BOTTOM VIEW

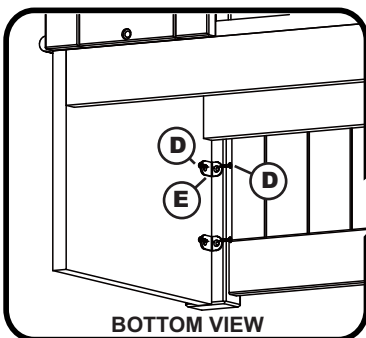

BOTTOM VIEW

STEP 10

Lastly, slide Trundle bed under the bed and drawer under the bookshelf as shown below.

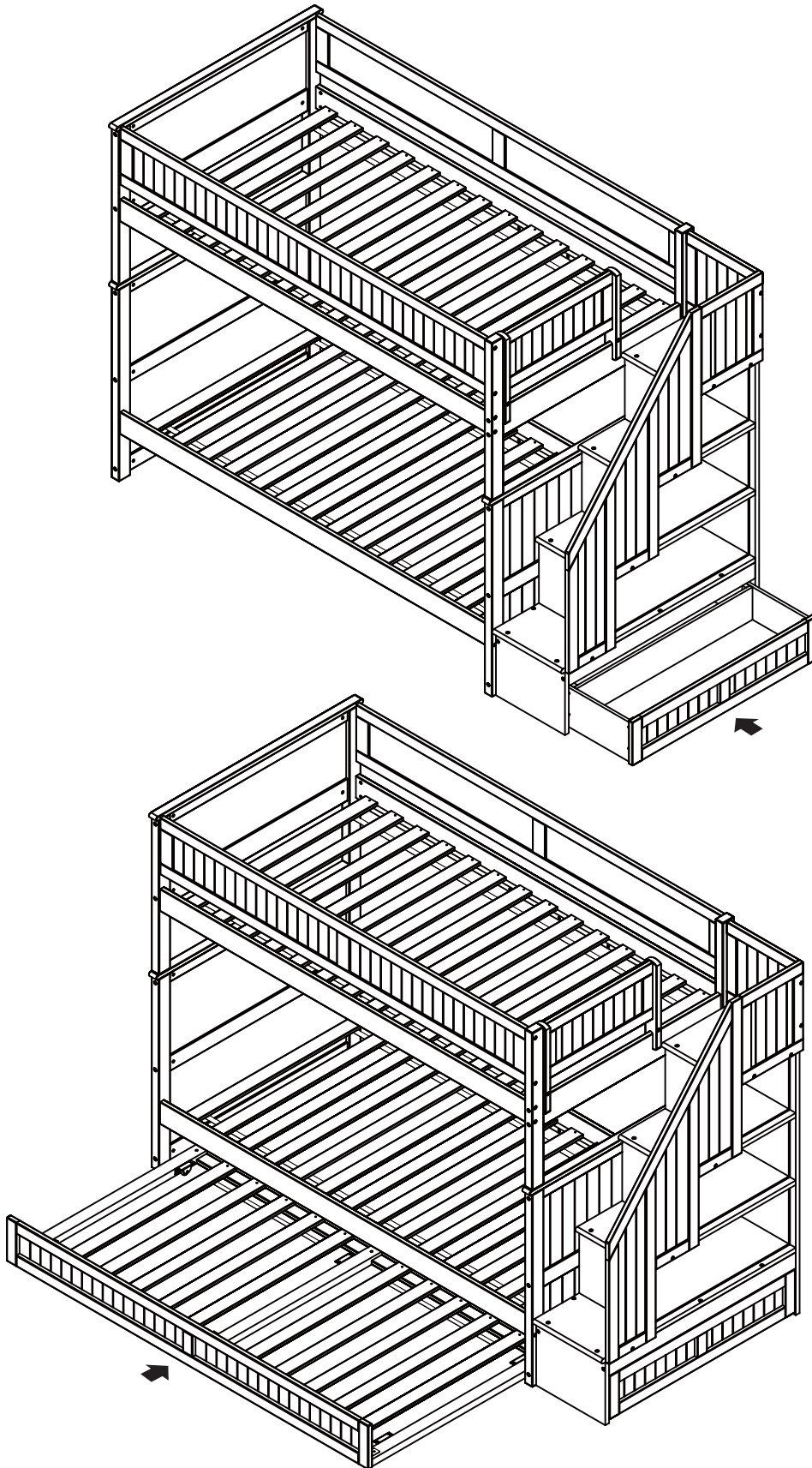

Congratulations!

Your staircase bookshelf bunk bed is now ready for use. We recommend that you periodically check that all screws are tight and all parts are secure to ensure lasting safety.