

## TWIN XL

### ASSEMBLY INSTRUCTIONS

Before assembling your bed frame, please read through these instructions carefully and familiarize yourself with the different parts.







**ATTENTION!** If you receive a damaged or defective item, please contact afifurnishings at [customerservice@afifurnishings.com](mailto:customerservice@afifurnishings.com) or 1-800-955-3726

#### PARTS LIST

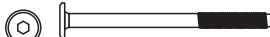
- |   |                   |              |
|---|-------------------|--------------|
| ① | <b>FOOT RAIL</b>  | <b>1 PC</b>  |
| ② | <b>LEFT LEG</b>   | <b>1 PC</b>  |
| ③ | <b>RIGHT LEG</b>  | <b>1 PC</b>  |
| ④ | <b>SIDE RAILS</b> | <b>2 PCS</b> |
| ⑤ | <b>SLAT KIT</b>   | <b>2 SET</b> |

#### HARDWARE

- |  |  |
|--|--|
| <b>A</b>  JCB M6 X 100mm (4") - 2 pcs<br>Spare - 1 pc           | <b>E</b>  Wood screw(1 1/4") - 12 pcs<br>Spare - 1 pc |
| <b>B</b>  Barrel nut - 2 pcs                                    | <b>F</b>  Allen wrench M4 - 1 pc<br>Spare - 1 pc      |
| <b>C</b>  Wood dowel 10 X 40mm( 1 5/8") - 4 pcs<br>Spare - 1 pc |  |
| <b>D</b>  Wood button - 2 pcs<br>Spare - 1 pc                   |  |

NOTE: WE INCLUDE SPARE HARDWARE IN CASE DAMAGE OCCURS DURING ASSEMBLY.

#### Step 1

Attach the legs (2) and (3) to foot rail (1), using wood dowel (C) JCB M6 X 100mm (A) and barrel nut (B).  
Tighten with the Allen wrench (F).  
Cover holes with wood button (D) as shown.

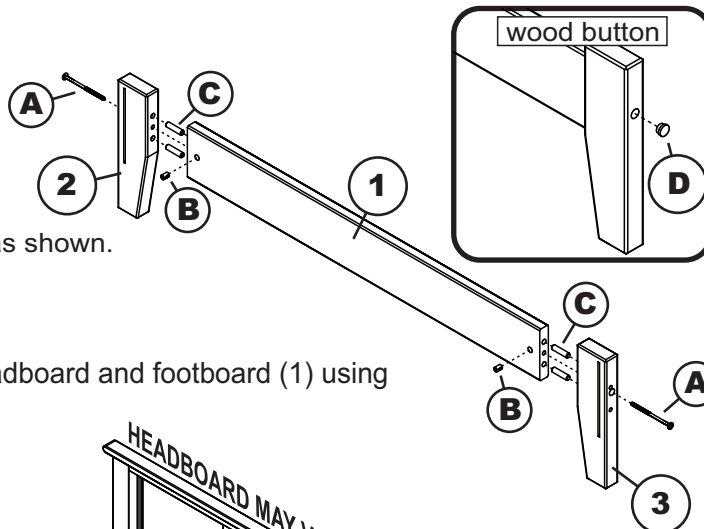

#### Step 2

Attach the side rails (04) to the headboard and footboard (1) using the bed hook as shown below.

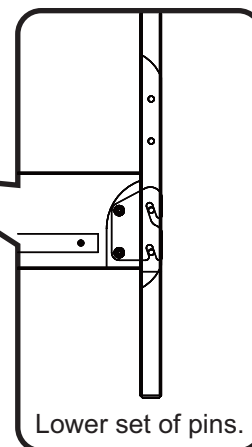
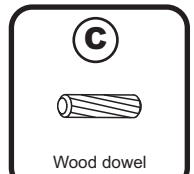
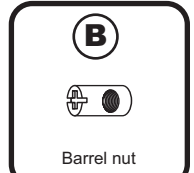
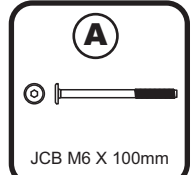
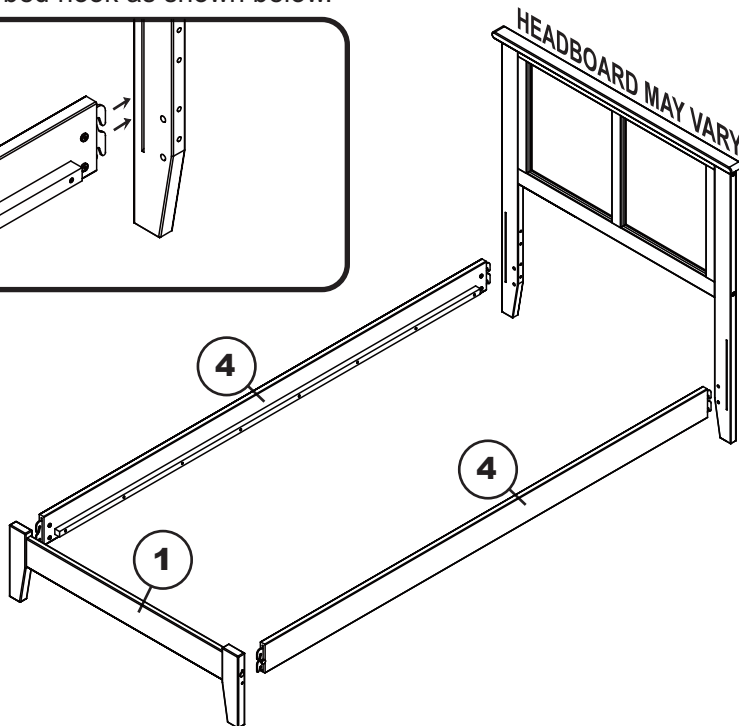
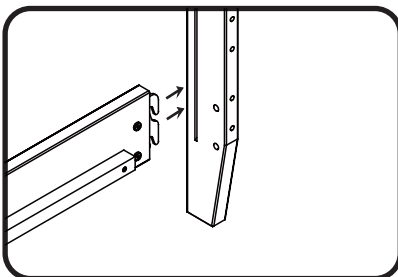

**PO:**

<b>CODE</b>	<b>ITEM</b>
FR-UBN2-LOO	R-26621X

## TWIN XL

### Step 3

Attach slat kit (5) to the bed as shown below. Using wood screw (E) tighten with Phillips head screwdriver. ( Customer supplied )

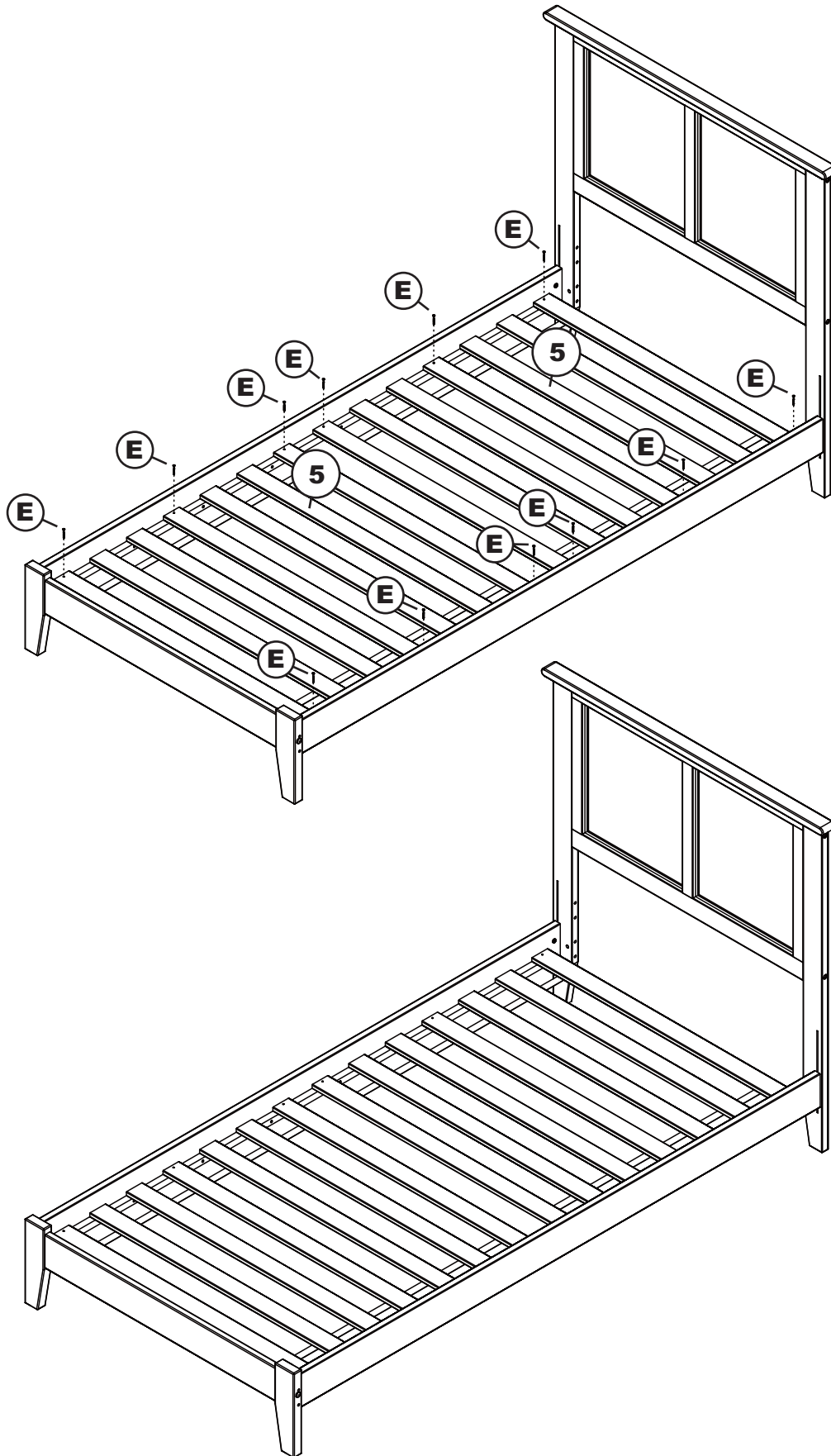

**Congratulations!**

Your bed is now ready for use.

We recommend that you periodically recheck that all screws are tight to ensure lasting safety.

## ASSEMBLY INSTRUCTIONS

Before assembling your headboard, please read through these instructions carefully and familiarize yourself with the different parts.

**ATTENTION!** If you receive a damaged or defective item, please contact afifurnishings at [customerservice@afifurnishings.com](mailto:customerservice@afifurnishings.com) or 1-800-955-3726



### PARTS LIST

- ① HEADBOARD PANEL 1 PC
- ② LEFT LEG 1 PC
- ③ RIGHT LEG 1 PC
- ④ SPACER BLOCK 2 PCS
- ⑤ PACKING STICK 2 PCS

Instructions apply for bed sizes  
TWIN > FULL

### HARDWARE

- |   |   |   |
|---|---|---|
| <ul style="list-style-type: none"> <li>① Wooden dowel - 4 pcs<br/>Spare - 1 pc</li> <li>② JCB M6 X 70mm (2 3/4") - 4 pcs<br/>Spare - 1 pc</li> <li>③ Barrel nut - 4 pcs<br/>Spare - 1 pc</li> </ul> | <ul style="list-style-type: none"> <li>④ Wood screw - 4 pcs<br/>Spare - 1 pc</li> <li>⑤ Allen wrench - 1 pc<br/>Spare - 1 pc</li> </ul> | <p><b>HARDWARE FOR METAL BED FRAME</b></p> <ul style="list-style-type: none"> <li>⑥ JCB M6 X 25mm (1") - 4 pcs<br/>Spare - 1 pc</li> <li>⑦ Flat washer - 4 pcs<br/>Spare - 1 pc</li> <li>⑧ Split washer - 4 pcs<br/>Spare - 1 pc</li> </ul> |
|---|---|---|

NOTE: WE INCLUDE SPARE HARDWARE IN CASE DAMAGE OCCURS DURING ASSEMBLY.

### Step 1

Remove packing stick (5) from headboard panel (1) and **DISCARD**. Insert wooden dowels (A) to the locator holes on spacer block (4). Attach the spacer blocks (4) to the legs (2) and (3), using wood screws (D), as shown below. Tighten with Phillips screwdriver. (customer supplied)

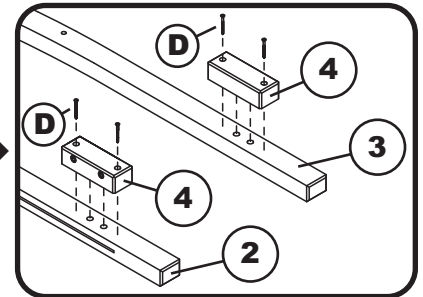
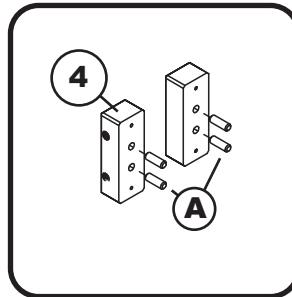
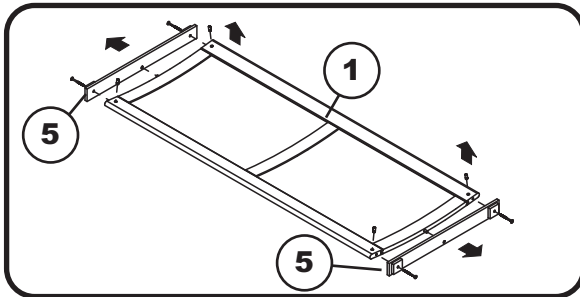

### Step 2

Attach the legs (2) and (3) to the headboard panel (1), using JCB (B) and barrel nut (C). Tighten with the Allen wrench (H).

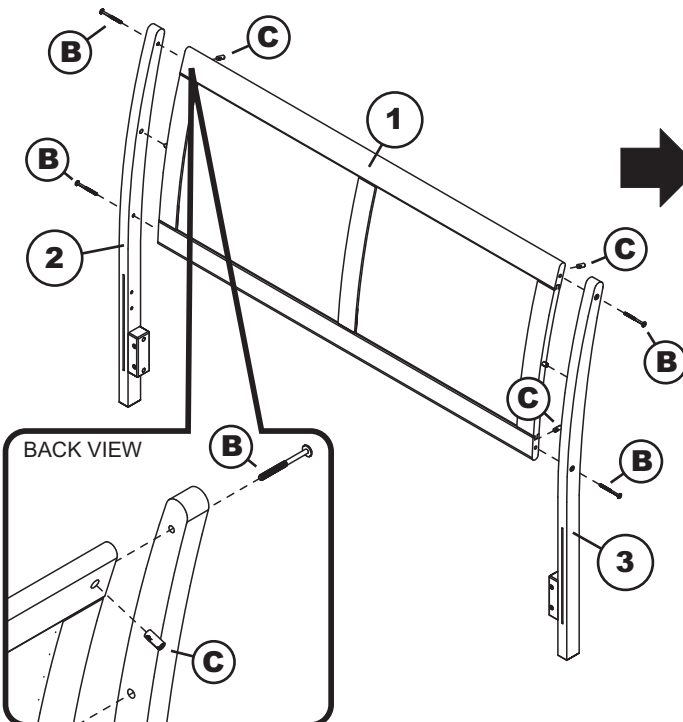

CODE	ITEM	ITEM
HB-POR	R-28982X	R-28983X

PO :

If you purchased a wood headboard to attach to metal bed frame, please refer to page 2.

**ASSEMBLY INSTRUCTIONS**

Before assembling your bed, please read through these instructions carefully and familiarize yourself with the different parts.

Instructions apply for bed sizes  
**Twin > Full**



Metal bed frames are sold separately from wood headboards. The hardware shown on this page is supplied with your wood headboard for attaching the bed frame to the headboard. The metal bed frame is supplied with its own assembly instructions and hardware.

**Step 1** Attach the headboard assembly to the metal frame using JCB (E), flat washer (F), and split washer (G) then tighten with Allen wrench (H), as shown below.

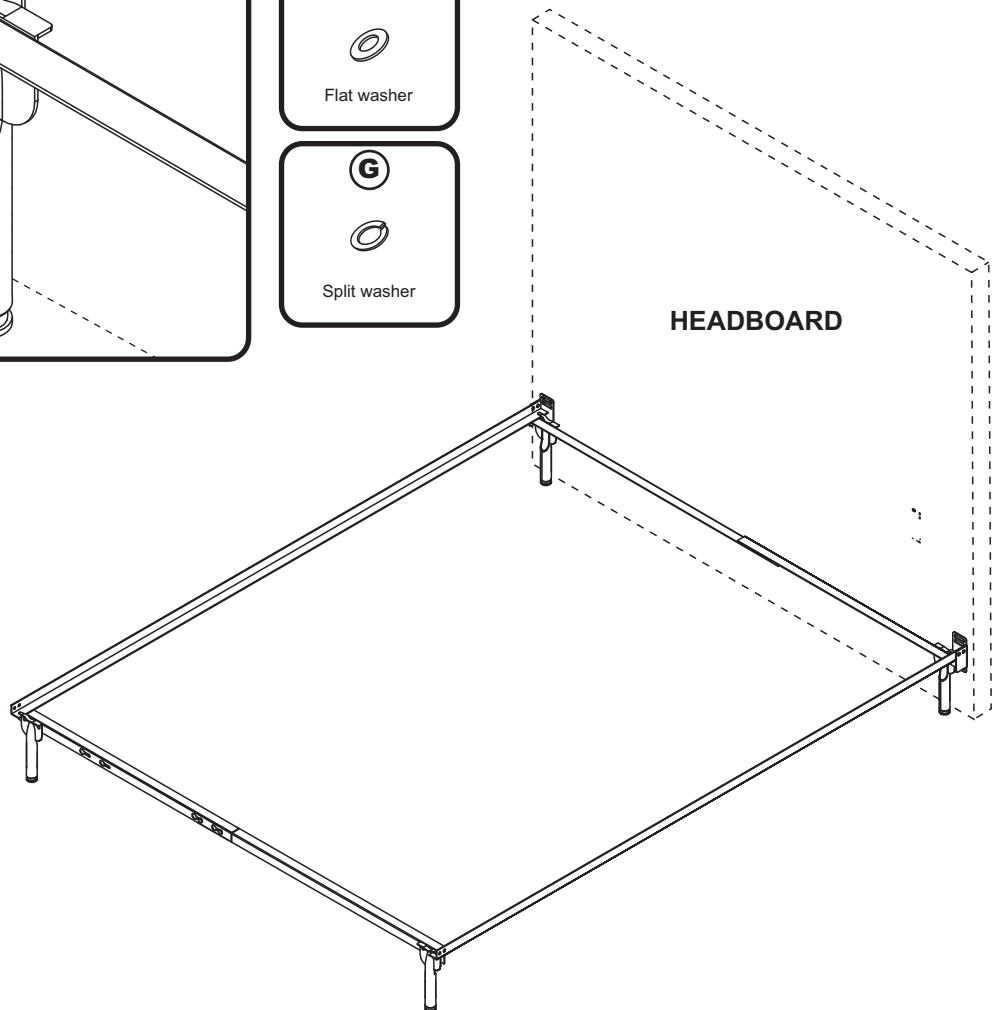
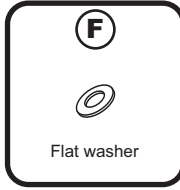
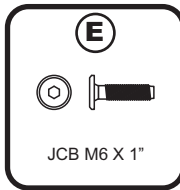
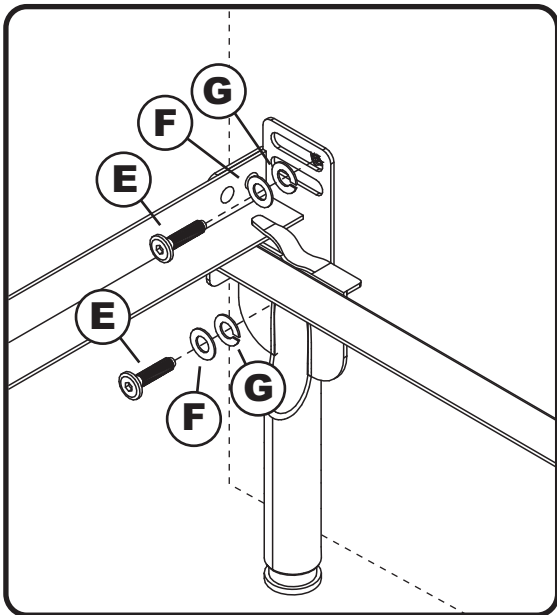

**Congratulations!**

Your Bed is now ready for use.  
To ensure lasting safety, we recommend that you periodically check that all screws are tight and all parts are secure.