

## ASSEMBLY INSTRUCTIONS

Before assembling your headboard, please read through these instructions carefully and familiarize yourself with the different parts.

**ATTENTION!** If you receive a damaged or defective item, please contact afifurnishings at [customerservice@afifurnishings.com](mailto:customerservice@afifurnishings.com) or 1-800-955-3726



### PARTS LIST

①	LEFT POST	1 PC
②	RIGHT POST	1 PC
③	TOP RAIL	1 PC
④	CENTER RAIL	3 PCS
⑤	BOTTOM RAIL	1 PC
⑥	SPACER BLOCK	2 PCS
⑦	SUPPORT RAIL	1 PC

Instructions apply for bed sizes  
**QUEEN > KING**

### HARDWARE

<b>A</b> JCB M8 X 40mm (1 1/2") - 4 pcs Spare - 1 pc	<b>D</b> Wood button - 4 pcs Spare - 1 pc	<b>G</b> JCB M6 X 25mm (1") - 4 pcs Spare - 1 pc
<b>B</b> JCB M6 X 40mm (1 1/2") - 2 pcs Spare - 1 pc	<b>E</b> Allen wrench M4 - 1pc	<b>H</b> Flat washer - 4 pcs Spare - 1 pc
<b>C</b> JCB M6 X 30mm (1 1/4") - 5 pcs Spare - 1 pc	<b>F</b> Allen wrench M5 - 1pc	<b>I</b> Split washer - 4 pcs Spare - 1 pc

#### HARDWARE FOR METAL BED FRAME

NOTE: WE INCLUDE SPARE HARDWARE IN CASE DAMAGE OCCURS DURING ASSEMBLY.

### Step 1

Attach spacer block (6) to left right post (1)(2), using JCB (B). Tighten with the Allen wrench (E).

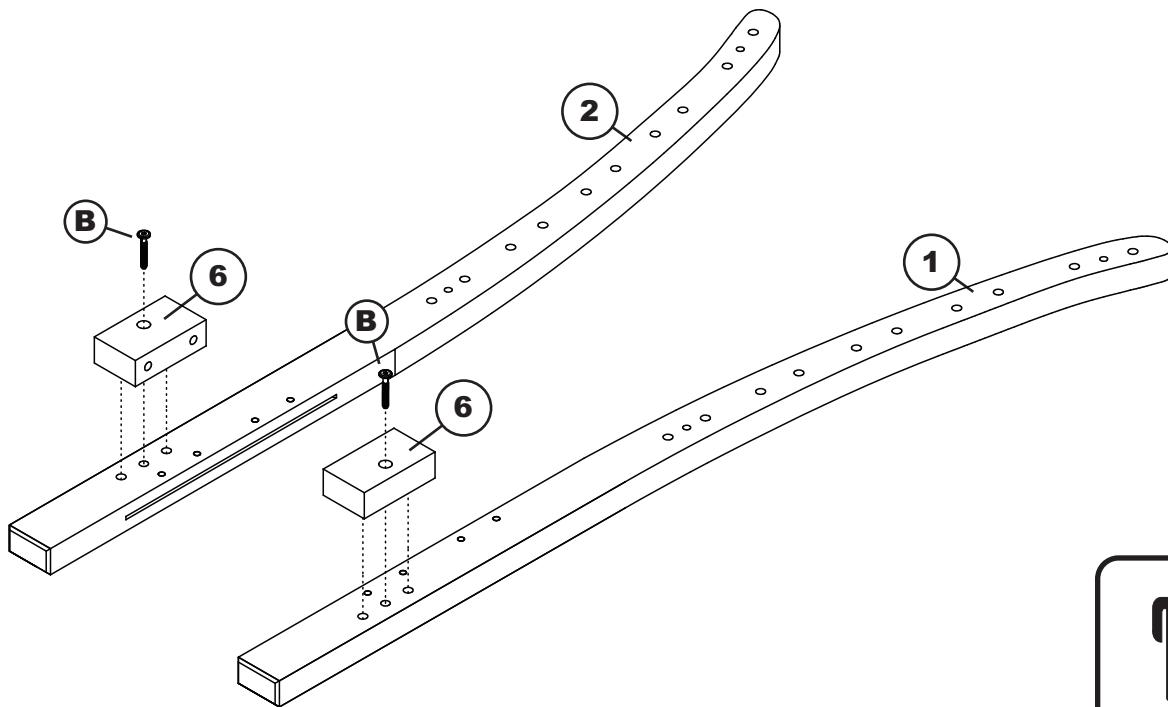

Adult assembly

**B**



JCB M6 X 40mm

**E**



Allen wrench M4

PO:

CODE	ITEM	ITEM
HB-SAV	R-29784X	R-29785X

QUEEN > KING

**Step 2**

Attach top rail (3) center rails (4) and bottom rail (5) to the left right post (1)(2) as shown below. Using JCB (A) tighten with Allen wrench (F).

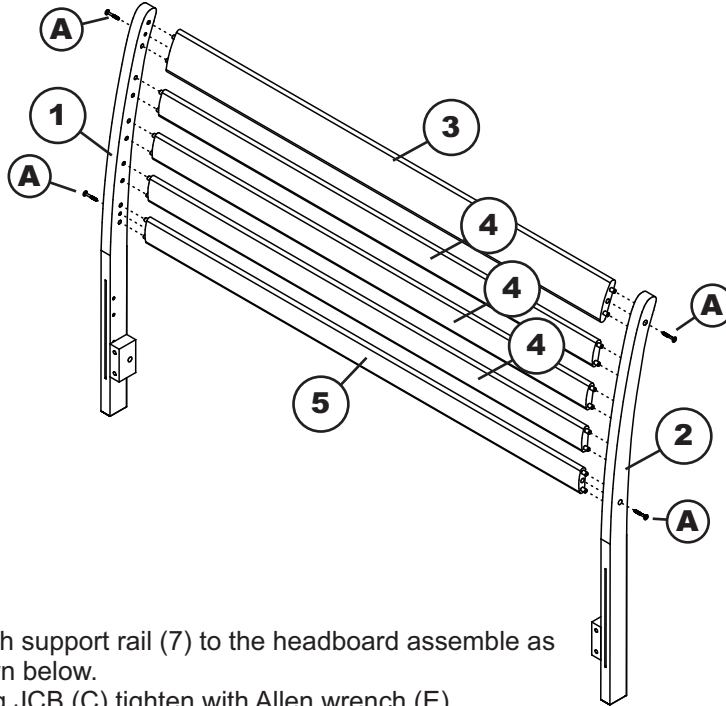

**Step 3**

Attach support rail (7) to the headboard assemble as shown below. Using JCB (C) tighten with Allen wrench (E).

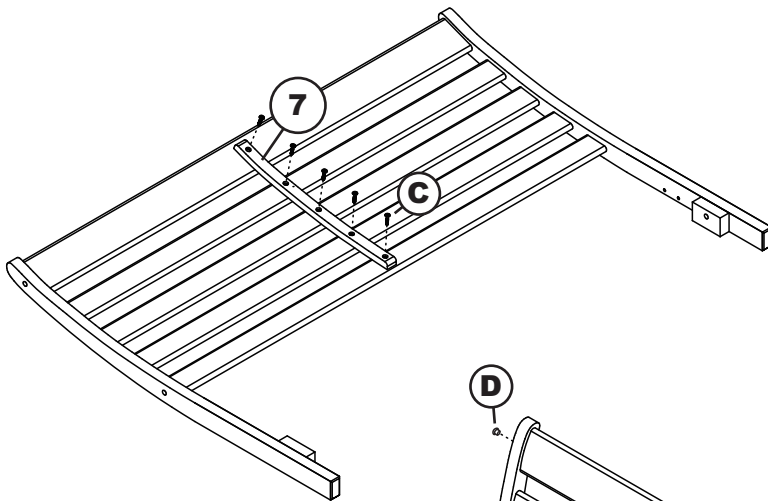

**Step 4**

Lastly, cover holes with wood button (D).

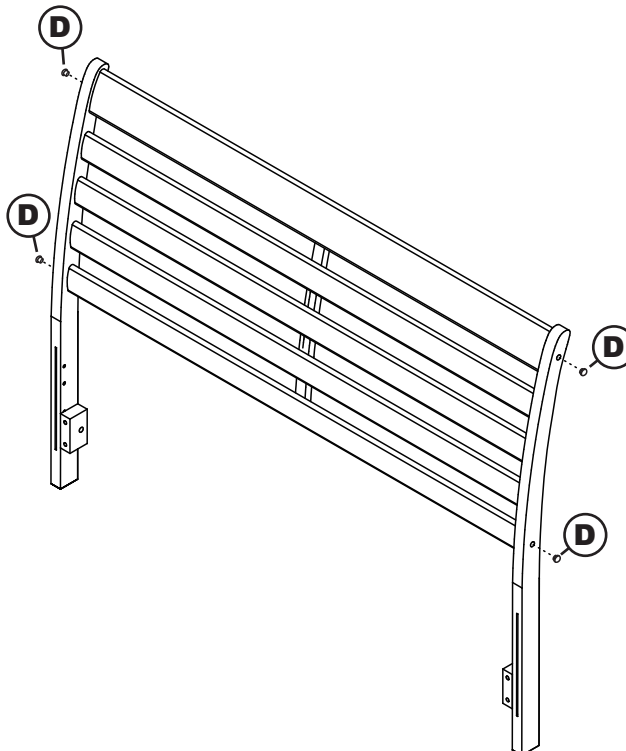

Adult assembly

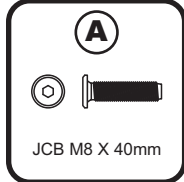

JCB M8 X 40mm

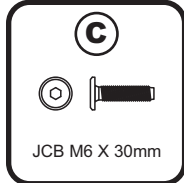

JCB M6 X 30mm



Wood button

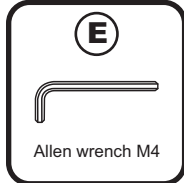

Allen wrench M4

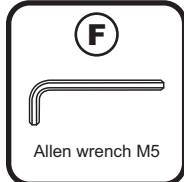

Allen wrench M5

If you purchased a wood headboard to attach to metal bed frame, please refer to page 3.

## QUEEN

### ASSEMBLY INSTRUCTIONS

Before assembling your bed frame, please read through these instructions carefully and familiarize yourself with the different parts.



**ATTENTION!** If you receive a damaged or defective item, please contact afifurnishings at [customerservice@afifurnishings.com](mailto:customerservice@afifurnishings.com) or 1-800-955-3726

#### PARTS LIST

- |   |                 |       |
|---|-----------------|-------|
| 1 | FOOT RAIL       | 1 PC  |
| 2 | LEFT LEG        | 1 PC  |
| 3 | RIGHT LEG       | 1 PC  |
| 4 | SIDE RAILS      | 2 PCS |
| 5 | SLAT KIT        | 2 SET |
| 6 | HB SUPPORT RAIL | 1 PC  |
| 7 | FB SUPPORT RAIL | 1 PC  |
| 8 | SUPPORT LEGS    | 3 PCS |

#### HARDWARE

- |   |   |   |   |
|---|---|---|---|
| A | JCB M6 X 70mm (2 3/4") - 2 pcs<br>Spare - 1 pc        | F | Cap Nut - 6 pcs                                 |
| B | Barrel nut - 2 pcs                                    | G | JCB M8 X 40mm ( 1 5/8") - 3 pcs<br>Spare - 1 pc |
| C | Wood dowel 10 X 30mm( 1 1/4") - 4 pcs<br>Spare - 1 pc | H | Wood screw(1 1/4") - 14 pcs<br>Spare - 1 pc     |
| D | Wood button - 2 pcs<br>Spare - 1 pc                   | I | Allen wrench M4 - 1pc<br>Spare - 1pc            |
| E | JCB M6 X 30mm ( 1 1/8") - 6 pcs<br>Spare - 1 pc       | J | Allen wrench M5 - 1pc                           |

NOTE: WE INCLUDE SPARE HARDWARE IN CASE DAMAGE OCCURS DURING ASSEMBLY.

#### Step 1

Attach the legs (2) and (3) to foot rail (1), using wood dowel (C) JCB M6 X 70mm (A) and barrel nut (B).  
Tighten with the Allen wrench (I).  
Cover holes with wood button (D) as shown.

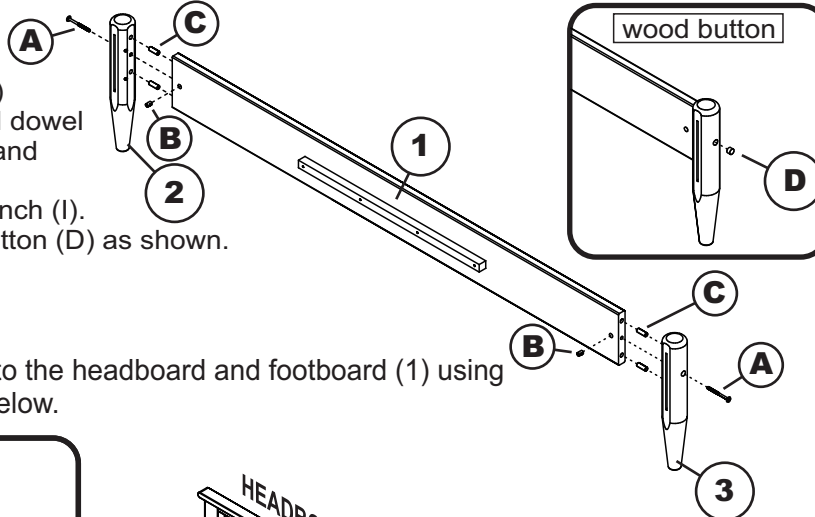

#### Step 2

Attach the side rails (04) to the headboard and footboard (1) using the bed hook as shown below.

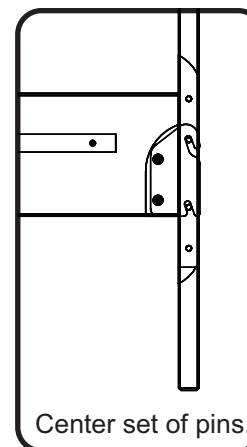
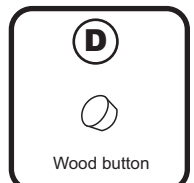
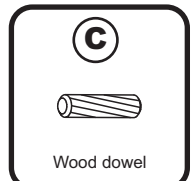
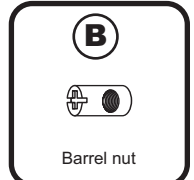
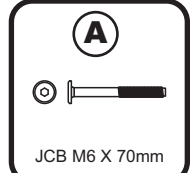
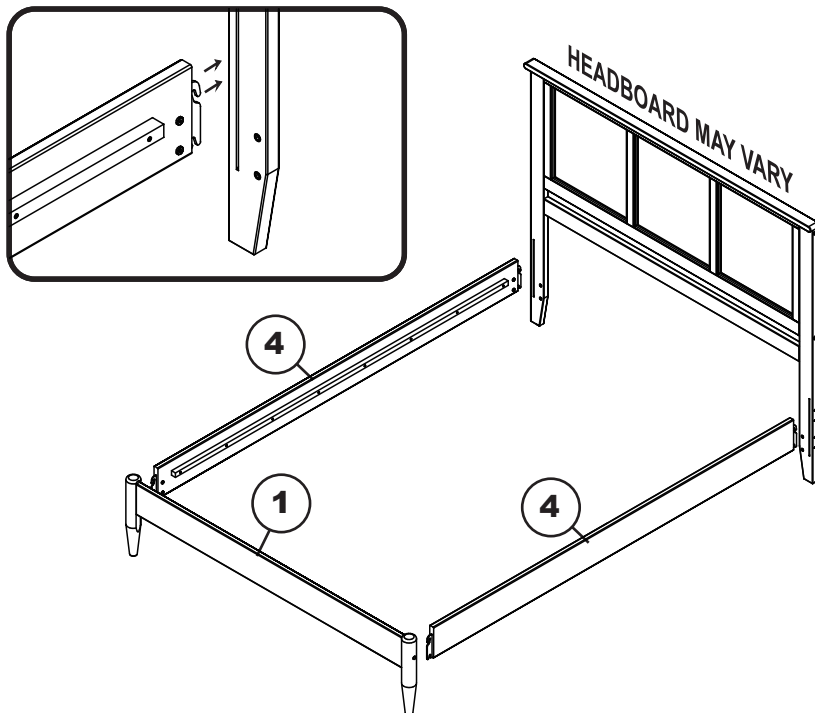

PO:

CODE	ITEM
FR-PDA-STO	R-21034X

# QUEEN

## Step 3

Attach support leg (8) to support rail (6)(7) as shown below. Using JCB M8 (G) tighten with Allen wrench M5 (J).

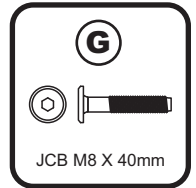
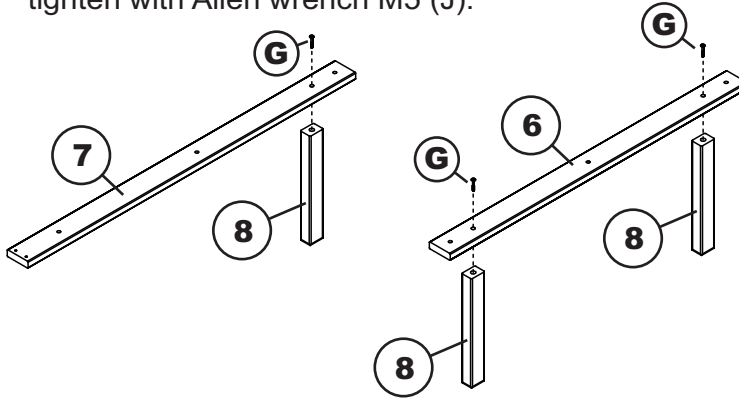

## Step 4

Attach HB support rail (6) and FB support rail (7) to the slat kit (5) as shown below using JCB M6 X 30mm (E) and cap nut (F). Tighten with Allen wrench M4 (I). Using wood screw (H) tighten with Phillips head screwdriver. (Customer supplied)

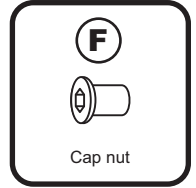
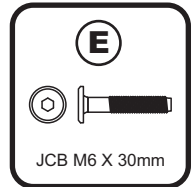
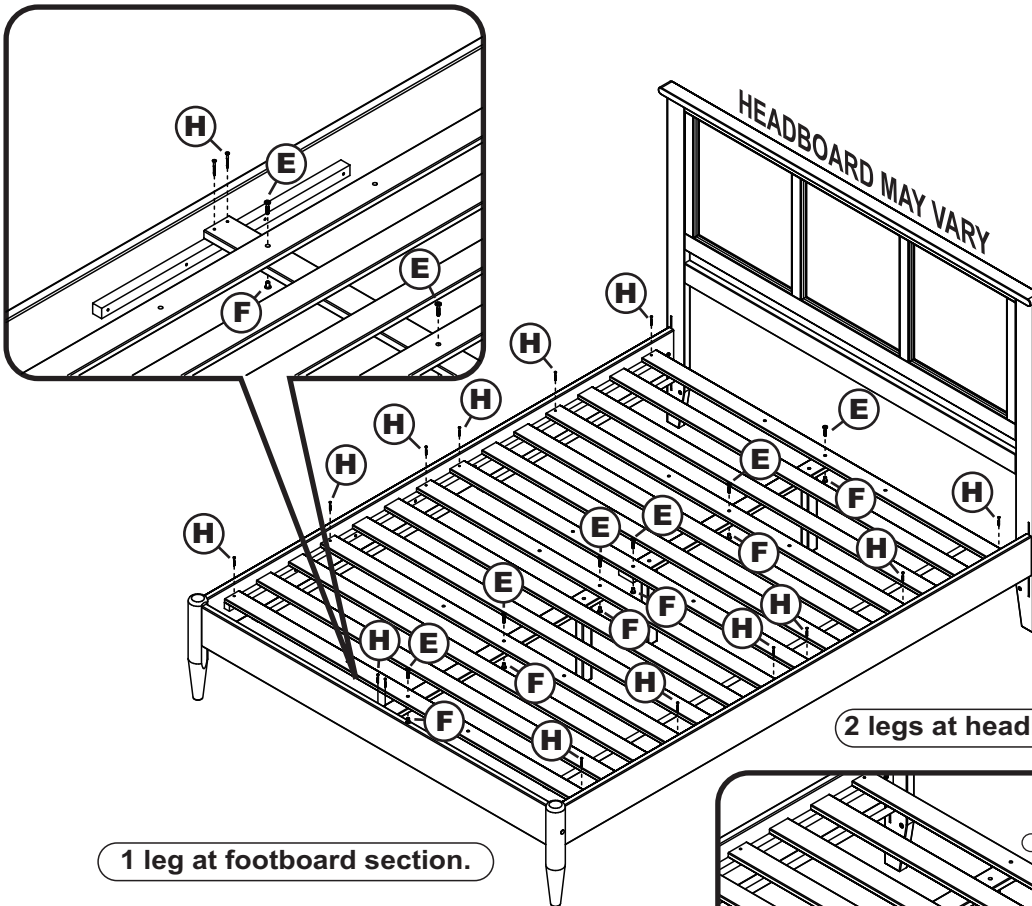

2 legs at headboard section.

1 leg at footboard section.

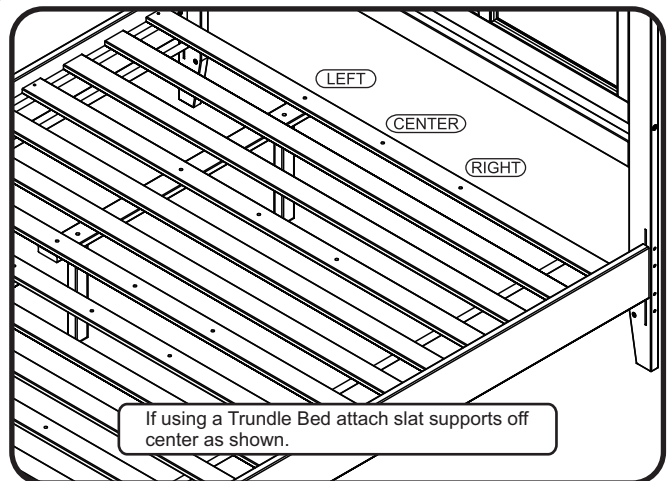

If using a Trundle Bed attach slat supports off center as shown.

## Congratulations!

Your bed is now ready for use.

We recommend that you periodically recheck that all screws are tight to ensure lasting safety.