

## ASSEMBLY INSTRUCTIONS

Before assembling your headboard, please read through these instructions carefully and familiarize yourself with the different parts.

**ATTENTION!** If you receive a damaged or defective item, please contact afifurnishings at [customerservice@afifurnishings.com](mailto:customerservice@afifurnishings.com) or 1-800-955-3726



### PARTS LIST

- ① LEFT POST 1 PC
- ② RIGHT POST 1 PC
- ③ TOP RAIL 1 PC
- ④ MID RAIL 1 PC
- ⑥ BOTTOM RAIL 1 PC

Instructions apply for bed sizes  
TWIN > FULL > QUEEN

### HARDWARE

- ⓐ JCB M6 X 110mm - 4 pcs  
Spare - 1 pc
- ⓑ Barrel Nut - 4 pcs  
Spare - 1 pc
- ⓒ JCB M8 X 15mm ( 5/8" ) - 4 pcs  
*Assembly headboard to open bed frame*
- ⓓ Wood Dowel - 10 pcs  
Spare - 1 pc
- ⓔ Allen wrench - 1pc  
Spare - 1pc

#### HARDWARE FOR METAL BED FRAME

- ⓕ JCB M6 X 25mm (1") - 4 pcs  
Spare - 1 pc
- ⓖ Flat washer - 4 pcs  
Spare - 1 pc
- ⓗ Split washer - 4 pcs  
Spare - 1 pc

NOTE: WE INCLUDE SPARE HARDWARE IN CASE DAMAGE OCCURS DURING ASSEMBLY.

### Step 1

Insert all wooden dowels (D) into the locator holes on (3)(4) and(5) as shown below.

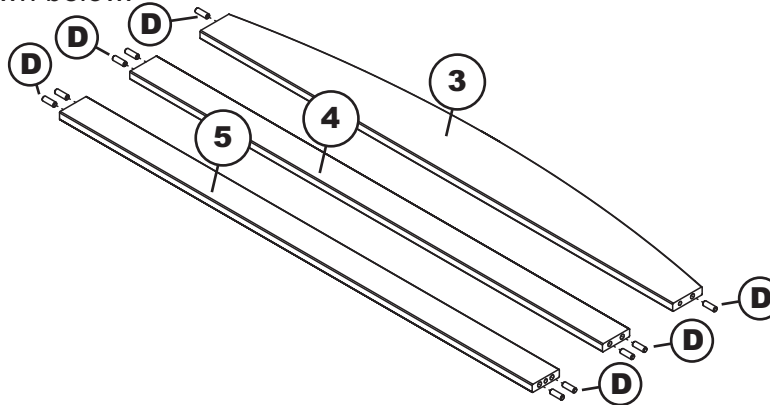

Adult assembly

ⓓ



Wood Dowel

### Step 2

Lay the left post (1) bracket face down on smooth surface. Connect top rail (3), mid rail (4) and bottom rail (5) as shown below, using JCB M6 X 110mm (A) and barrel nut (B). Tighten with the Allen wrench (E).

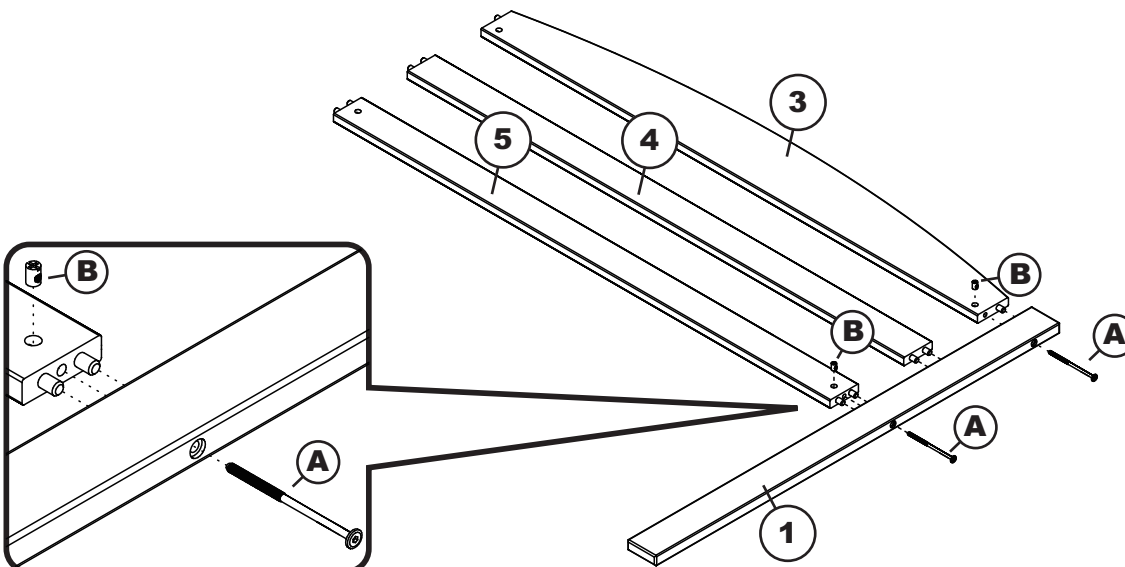

Adult assembly

ⓐ



JCB M6 X 110mm

ⓑ



Barrel Nut

PO:

CODE	ITEM	ITEM	ITEM
HB-ISL-WRN	G-11902X	G-11903X	G-11904X

### Step 3

Attach the right post (2) to headboard assembly as shown below, using JCB M6 X 110mm (A) and barrel nut (B). Tighten with Allen wrench (E)

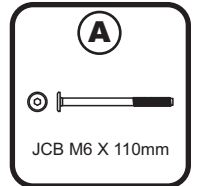
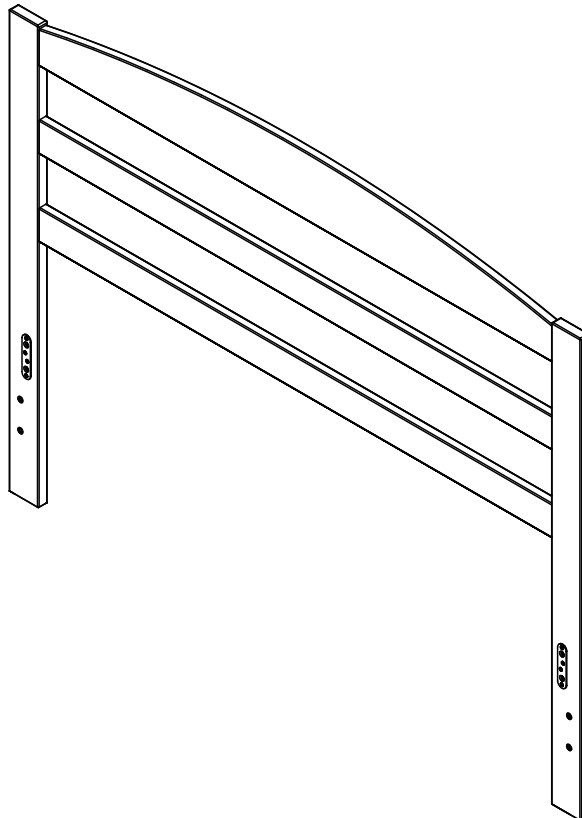
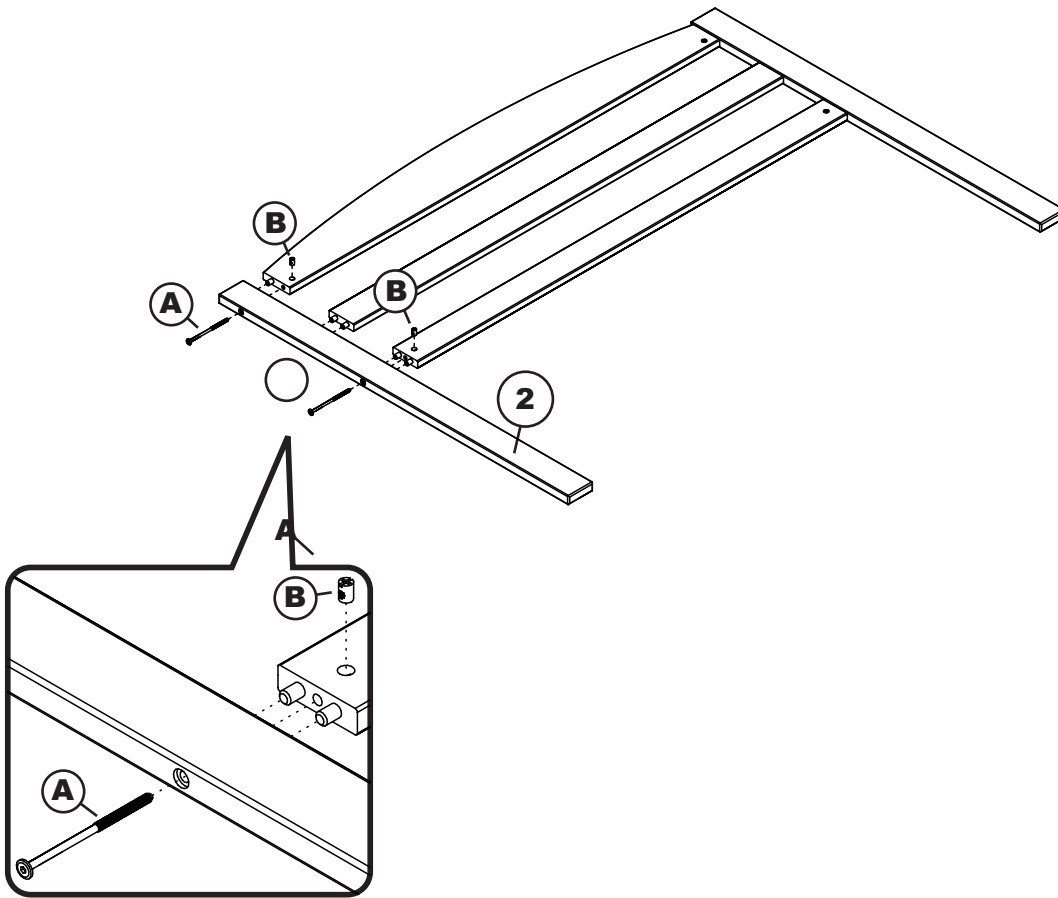

FOR BED FRAME ASSEMBLY follow assembly instructions included with your bed frame.  
If you purchased a wood headboard to attach to metal bed frame, please refer to page 3.

## QUEEN

### ASSEMBLY INSTRUCTIONS

Before assembling your bed frame, please read through these instructions carefully and familiarize yourself with the different parts.



**ATTENTION!** If you receive a damaged or defective item, please contact afifurnishings at customerservice@afifurnishings.com or 1-800-955-3726

#### PARTS LIST

①	<b>FOOT RAIL</b>	<b>1 PC</b>
②	<b>LEFT LEG</b>	<b>1 PC</b>
③	<b>RIGHT LEG</b>	<b>1 PC</b>
④	<b>SIDE RAILS</b>	<b>2 PCS</b>
⑤	<b>SLAT KIT</b>	<b>2 SETS</b>
⑥	<b>SLAT SUPPORT 1</b>	<b>1 PC</b>
⑦	<b>SLAT SUPPORT 2</b>	<b>1 PC</b>
⑧	<b>SUPPORT LEGS</b>	<b>3 PCS</b>

#### HARDWARE

①	JCB M6 X 110mm (4 3/8") - 2 pcs	Spare - 1 pc	⑤	JCB M6 X 30mm (1 1/4") - 6pcs
②	Barrel nut - 2 pcs		⑥	Cap nut - 6pcs
③	JCB M8 X 15mm (5/8") - 4 pcs		⑦	Allen wrench M6 - 1pc
④	Wood screw (1 1/4") - 29 pcs	Spare - 2 pcs	⑧	Allen wrench M4 - 1pc
			⑨	Split washer - 3pcs
			⑩	Spare - 1pc
			⑪	Flat washer - 3pcs
			⑫	Spare - 1pc

NOTE: WE INCLUDE SPARE HARDWARE IN CASE DAMAGE OCCURS DURING ASSEMBLY.

#### Step 1

Attach the legs (2) and (3) to foot rail (1), using JCB M6 X 110mm (A) and barrel nut (B).  
Tighten with the Allen wrench M4 (I).

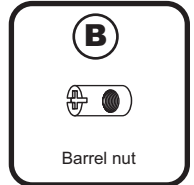
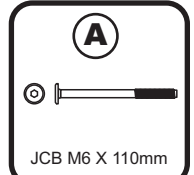
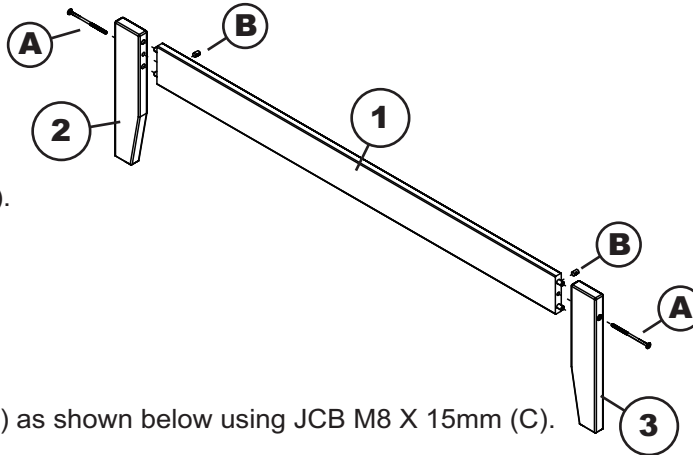

#### Step 2

Attach side rails (4) to the foot rail (1) as shown below using JCB M8 X 15mm (C).  
Tighten with Allen wrench M6 (H).

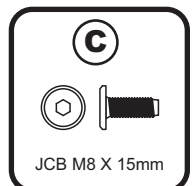
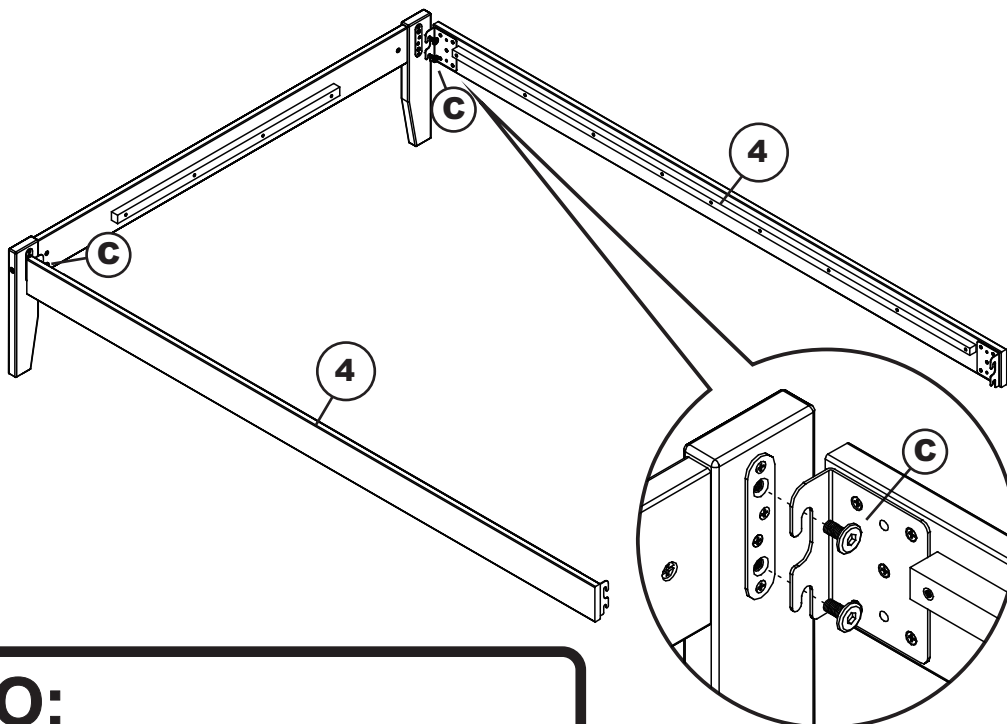

**PO:**

## QUEEN



### Step 3

Attach open bed frame to the headboard as shown below using 4 JCB M8 X 15mm bolts that are supplied with your headboard. Tighten with the Allen wrench M6 (H).

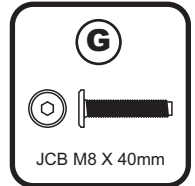
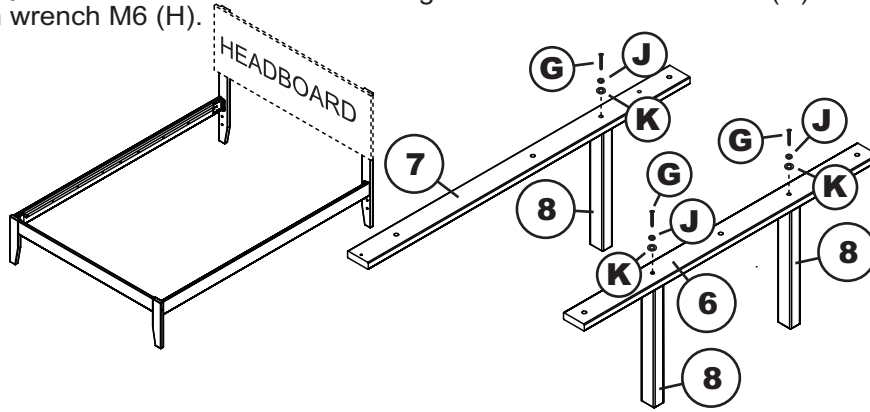
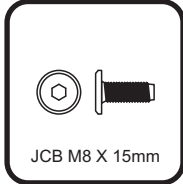

### Step 5

Attach slat support 1 (6) and slat support 2 (7) to the slat kit (5) as shown below using JCB M6 X 30mm (E) and cap nut (F). Tighten with Allen wrench M4 (I).

2 legs at headboard section.

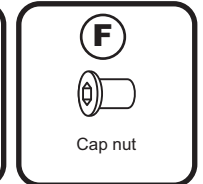
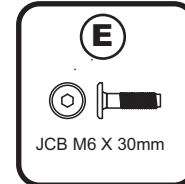
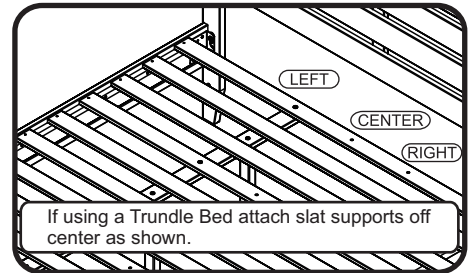
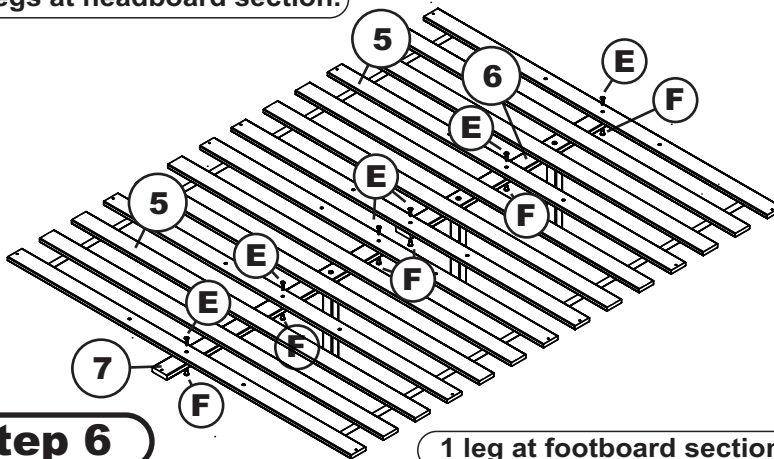

### Step 6

Attach 2 slat kits (5) to the open bed frame as shown below using wood screws 1 1/4" (D). Tighten with Phillips head screw driver. (customer supplied)

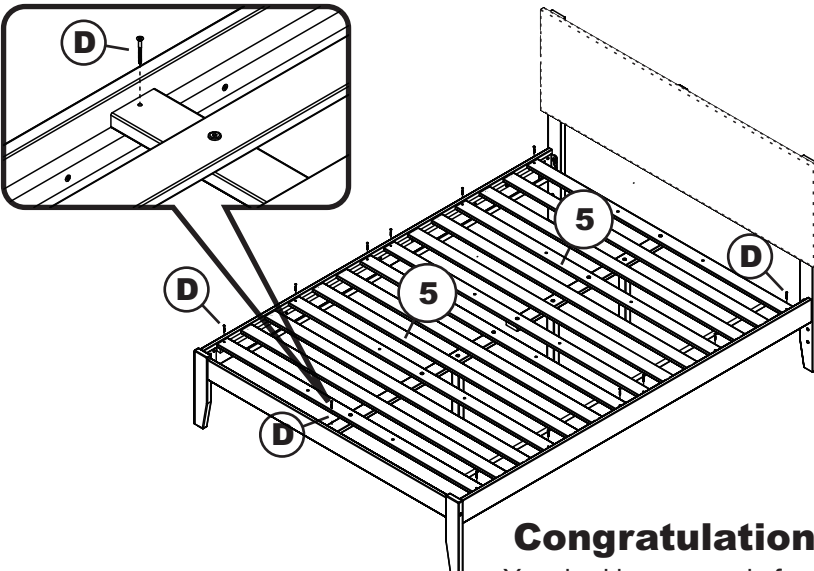

**Congratulations!**

Your bed is now ready for use.

We recommend that you periodically recheck that all screws are tight to ensure lasting safety.