

TWIN XL

ASSEMBLY INSTRUCTIONS

Before assembling your murphy bed, please read through these instructions carefully and familiarize yourself with the different parts.

ATTENTION! If you receive a damaged or defective item, please contact affurnishings at customerservice@afifurnishings.com or 1-800-955-3726

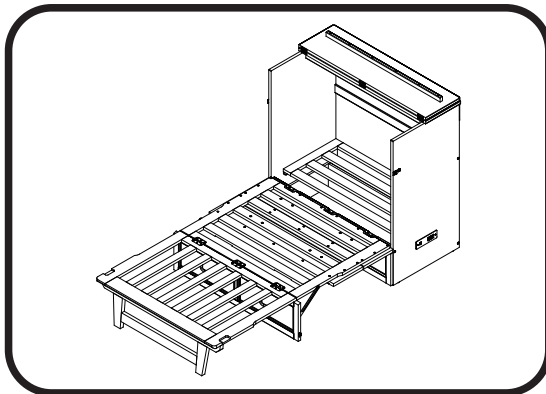
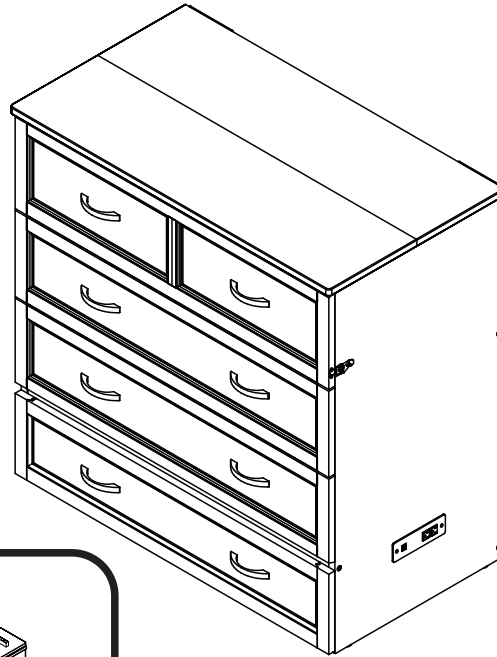

CODE	ITEM
MB-DP-NFD	C-5817X
MB-CB-NFD	C-5819X

PO :

HARDWARE

NOTE: WE INCLUDE SPARE HARDWARE IN CASE DAMAGE OCCURS DURING ASSEMBLY.

- A** 8 X 30mm Wood dowel - 26 pcs
Spare - 2 pcs
- B** JCB M6 X 25mm (1") - 10 pcs
Spare - 1 pc
- C** JCB M6 X 30mm (1 1/4") - 6 pcs
Spare - 1 pc
- D** JCB M6 X 60mm (2 3/8") - 8 pcs
Spare - 1 pc
- E** Barrel Nut - 6 pcs
Spare - 1 pc
- F** Wood screw 1" - 17 pcs
Spare - 2 pcs
- G** Wood screw 1 1/2" - 2 pcs
Spare - 1 pc
- H** Allen wrench - 1 pc
Spare - 1 pc
- I** Triangle Bracket - 2 pcs
- J** USB Charger - 1 pc
Black wood screw 5/8" - 4 pcs
Set with screw and cable fastener

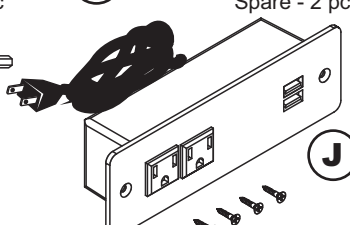
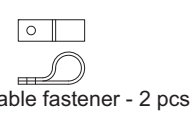
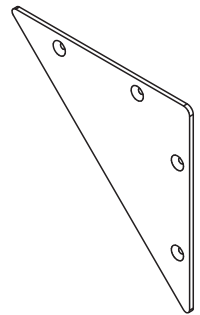

TWIN XL PARTS LIST

- 01 HARDWARE
- 02 TOP PANEL
- 03 LEFT SIDE PANEL
- 04 RIGHT SIDE PANEL
- 05 FRONT RAIL
- 06 SHELF
- 07 MIDDLE BACK RAIL
- 08 BOTTOM BACK RAIL
- 09 BACK PANEL
- 10 DOOR PANEL
- 11 DRAWER FACE
- 12 DRAWER SIDE
- 13 DRAWER BACK
- 14 DRAWER PANEL
- 15 DRAWER PANEL SUPPORT
- 16 DRAWER SIDE BLOCK
- 17 FOLDING MATTRESS

C-5819X
1 BOX

C-5817X
1 BOX

1 BOX

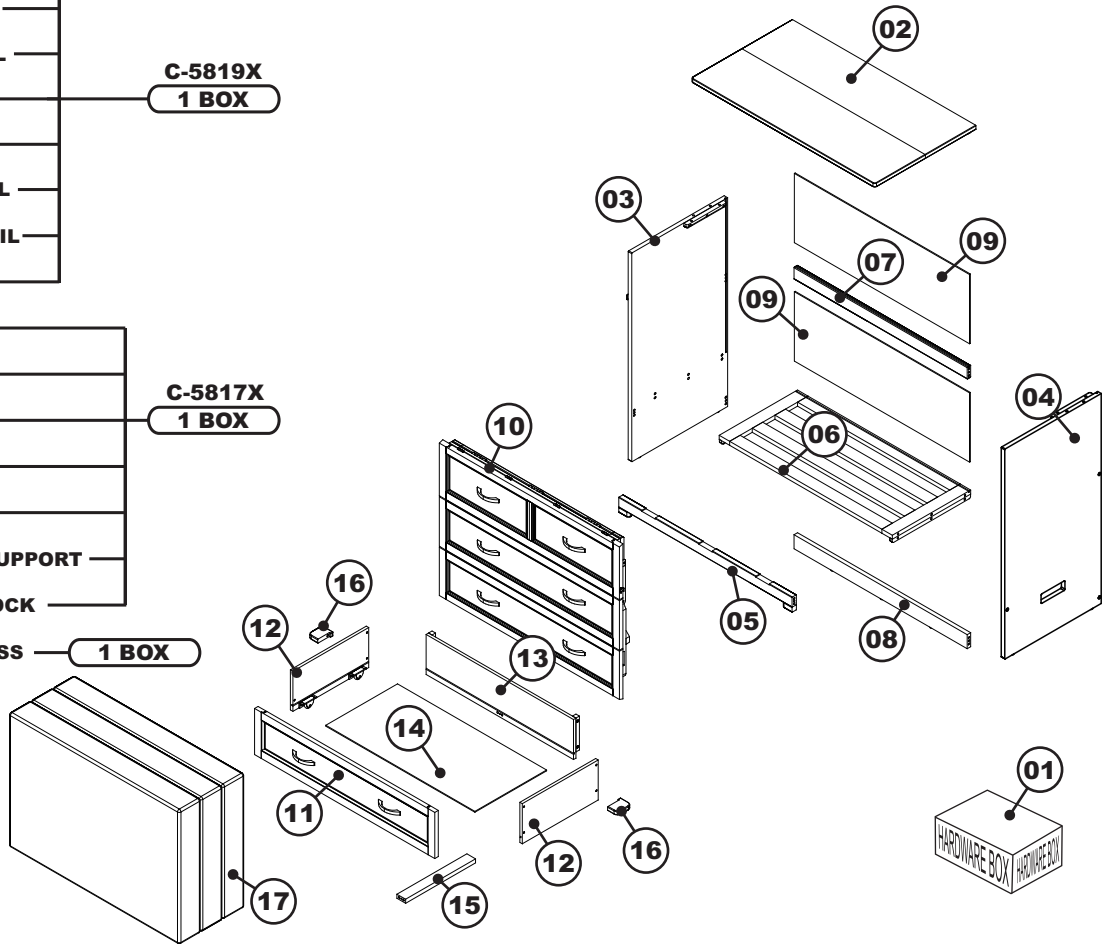

STEP 1

Insert all wooden dowels (A) into the locator holes on (03)(04)(05)(06)(07)(08) and (15). Install USB charger (J) as shown below. Using black wood screw and cable fastener tighten with phillips head screw driver. (Customer Supplied)

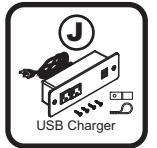
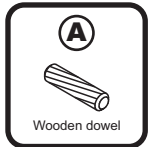
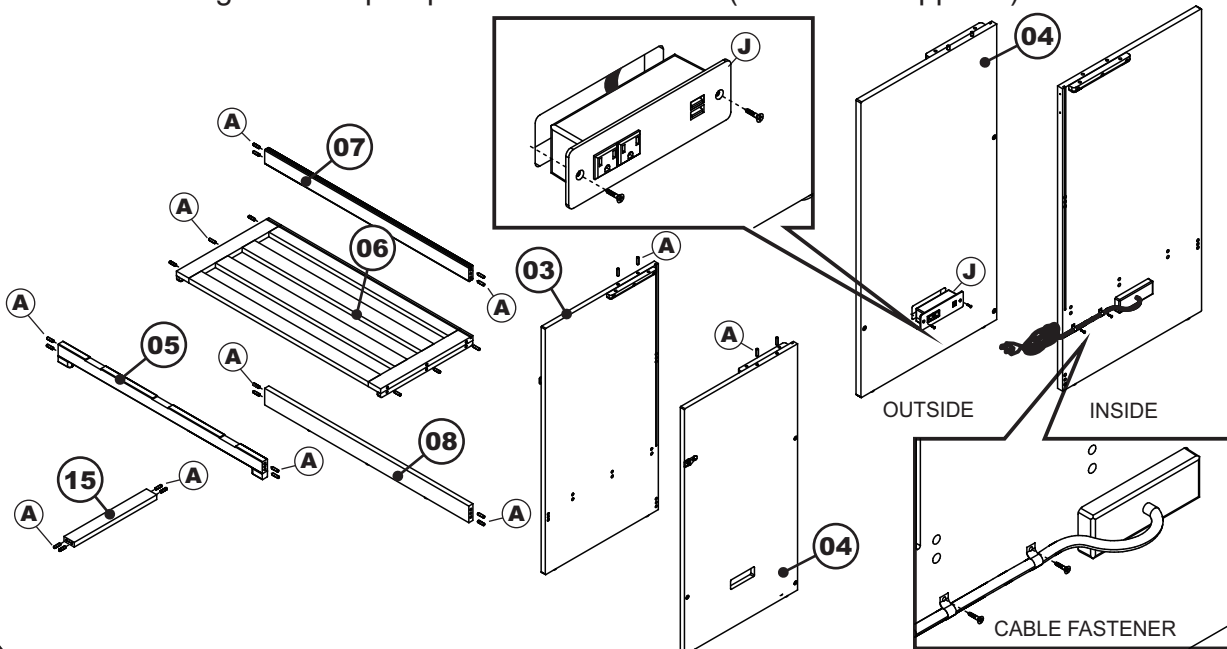

TWIN XL

STEP 2

Attach left side panels (03) to the shelf (06), front rail (05), middle back rail (07) and bottom back rail (08) as shown below. Use JCB (B)(D) and barrel nut (E). Tighten with Allen wrench (H)

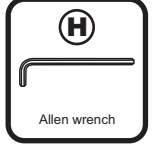
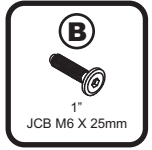
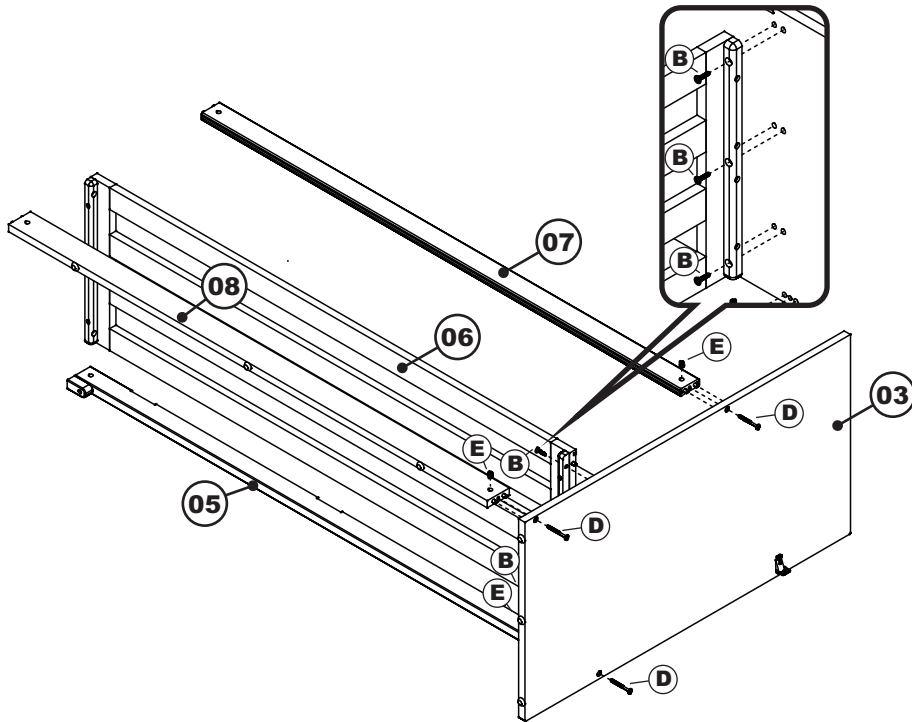

STEP 3

Guide the back panel (09) in carefully so that it won't jump out of its grooves. Be sure it fits fully into its groove at the bottom (in the side panel) before fitting the other side panel.

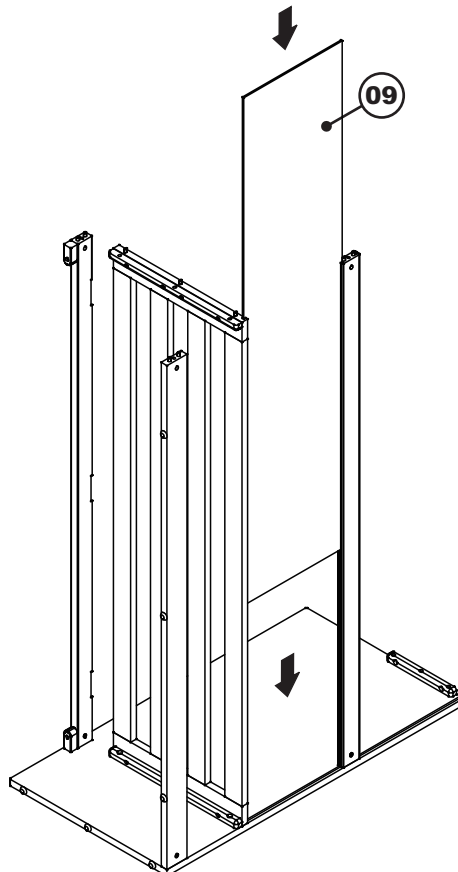

TWIN XL

STEP 4

Attach right side panels (04) to cabinet assembly as shown below. Use JCB (B)(D) and barrel nut (E). Tighten with Allen wrench (H). Be sure it fits fully into its groove at the bottom (in the side panel) before fitting the side panel.

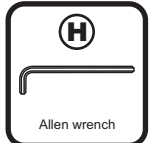
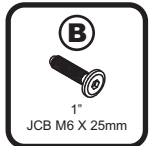
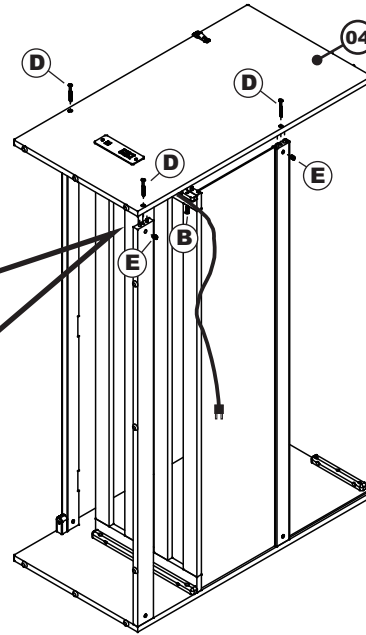
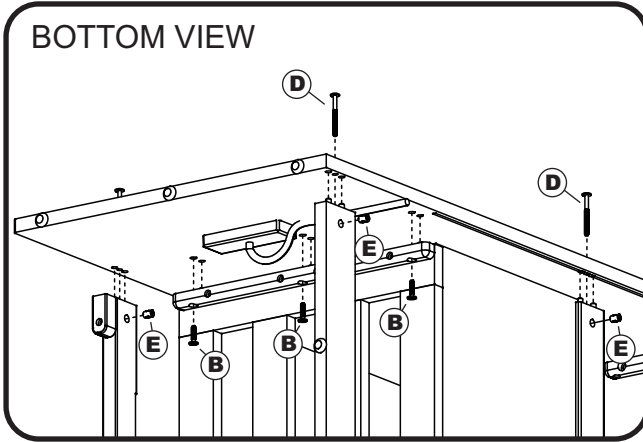

STEP 5

Guide the back panel (09) in carefully so that it won't jump out of its grooves. Be sure it fits fully into its groove at the middle rail before fitting the top panel.

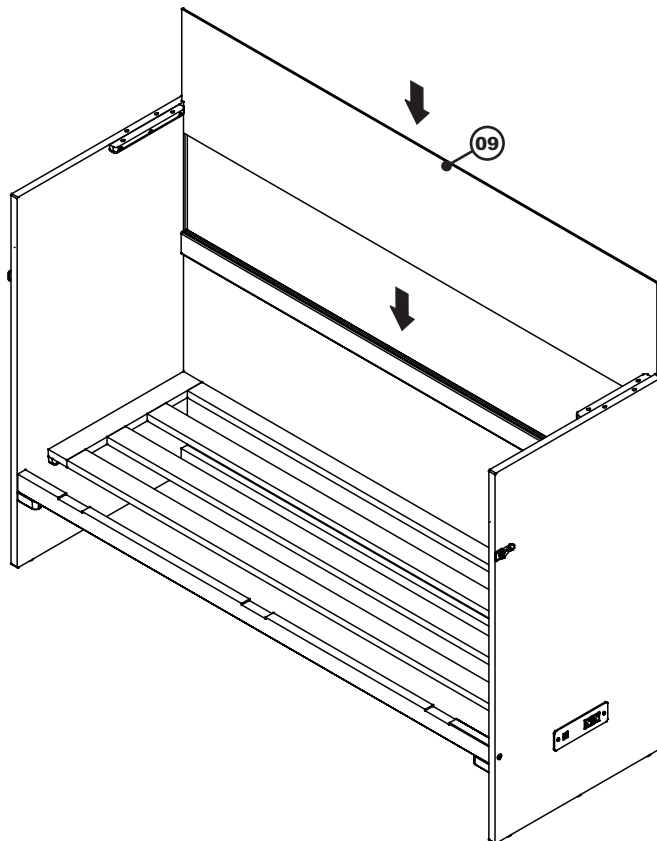

TWIN XL

STEP 6

Attach top panel (02) to cabinet assembly as shown below. Use JCB (B). Tighten with Allen wrench (H)

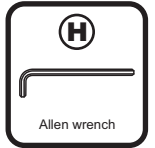
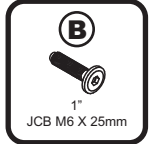
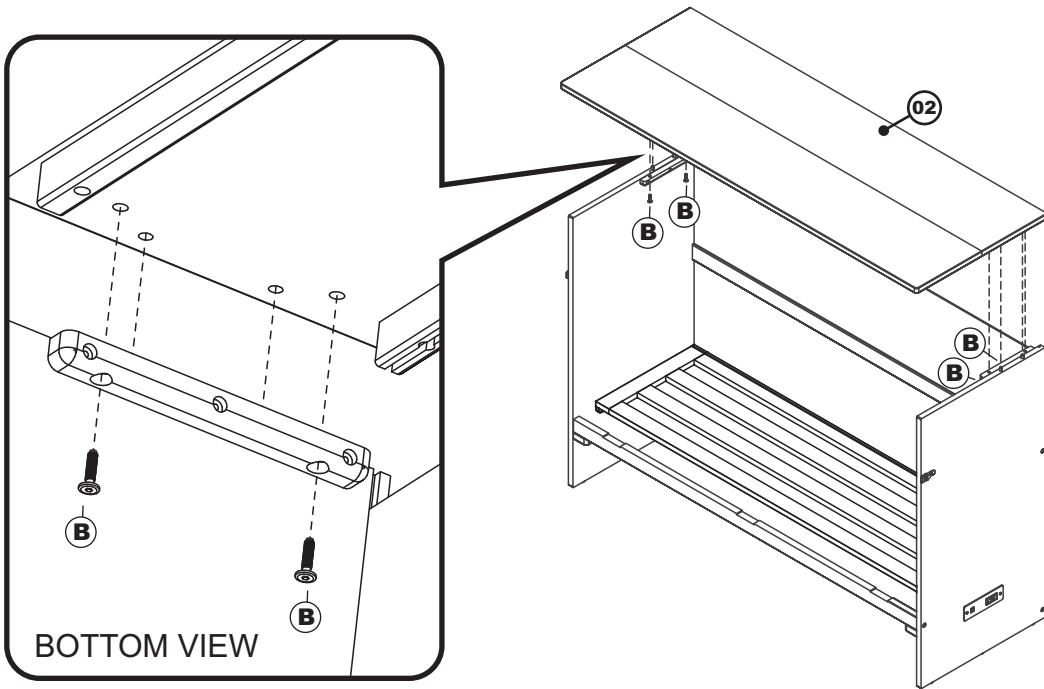

STEP 7

Open top drawer folding leg until lock of metal support as shown below.

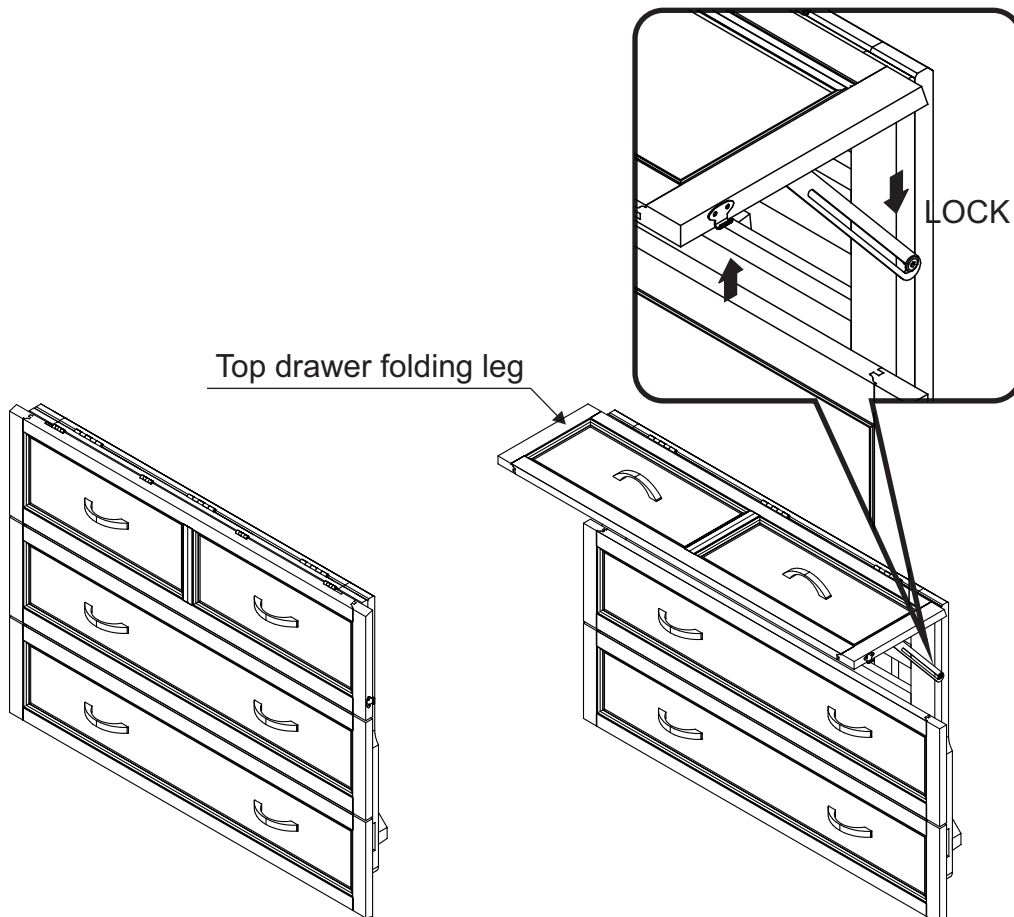

TWIN XL

STEP 8

Attach door panel to cabinet assembly as shown below. Use wood screw (F) tighten with Phillips head screwdriver. (customer supplied). Be sure to align with cabinet.

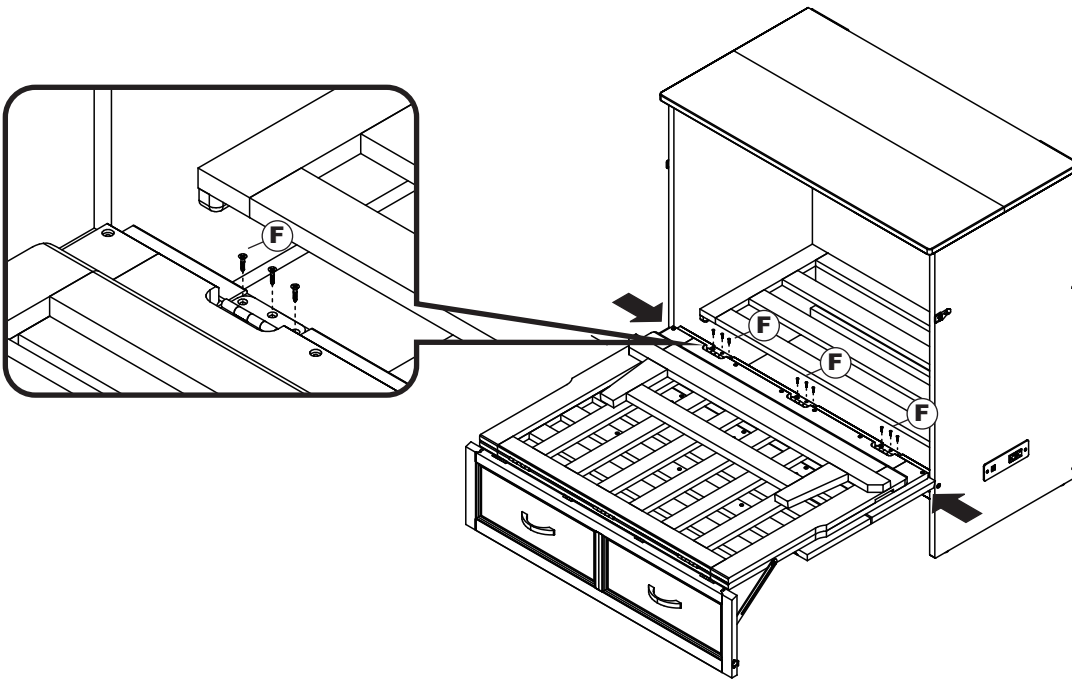

STEP 9

Lift the door and push the metal support. Push the door closed and latch both sides as shown below.

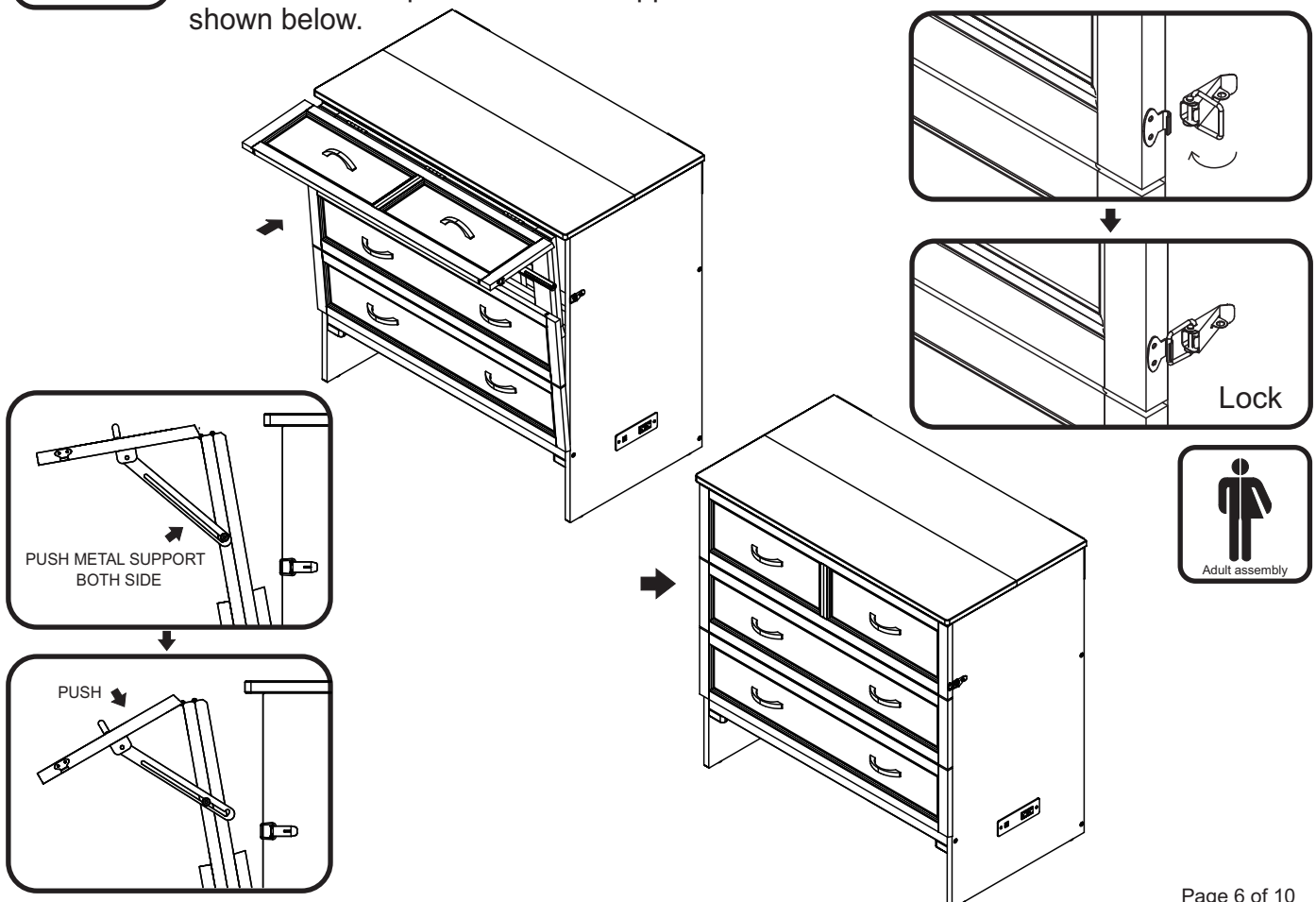

TWIN XL

STEP 10

Attach triangle bracket (I) to the back of cabinet as shown below. Use wood screw (F) tighten with Phillips head screwdriver. (customer supplied).

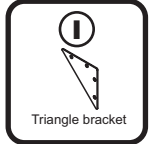
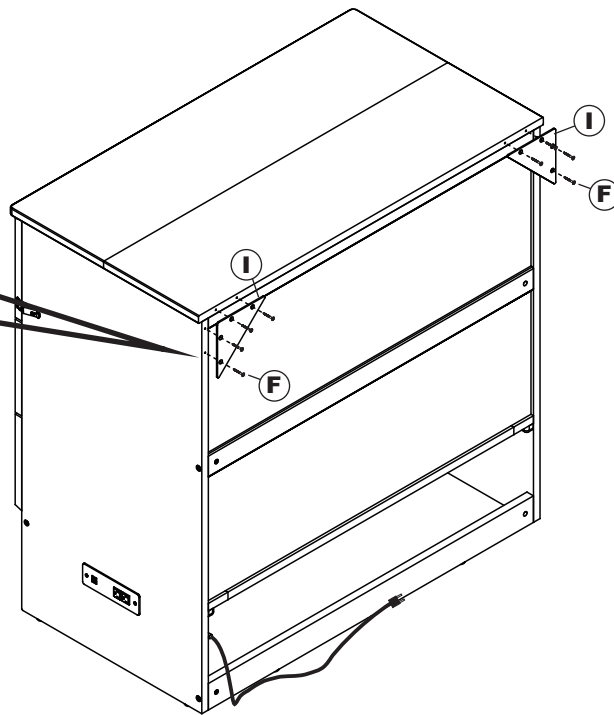
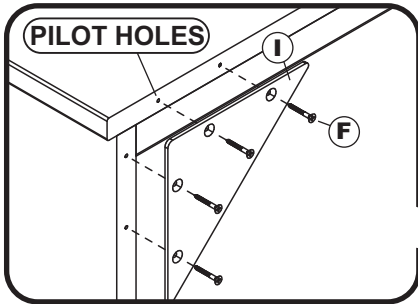

STEP 11

Lay the drawer face (11) on smooth, flat surface so the groove is facing upwards. Fit the drawer side (12) to drawer face (11), Use JCB (C), align groove inside panel with groove in drawer face. Tighten with Allen wrench (H).

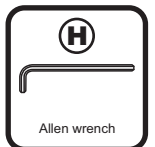
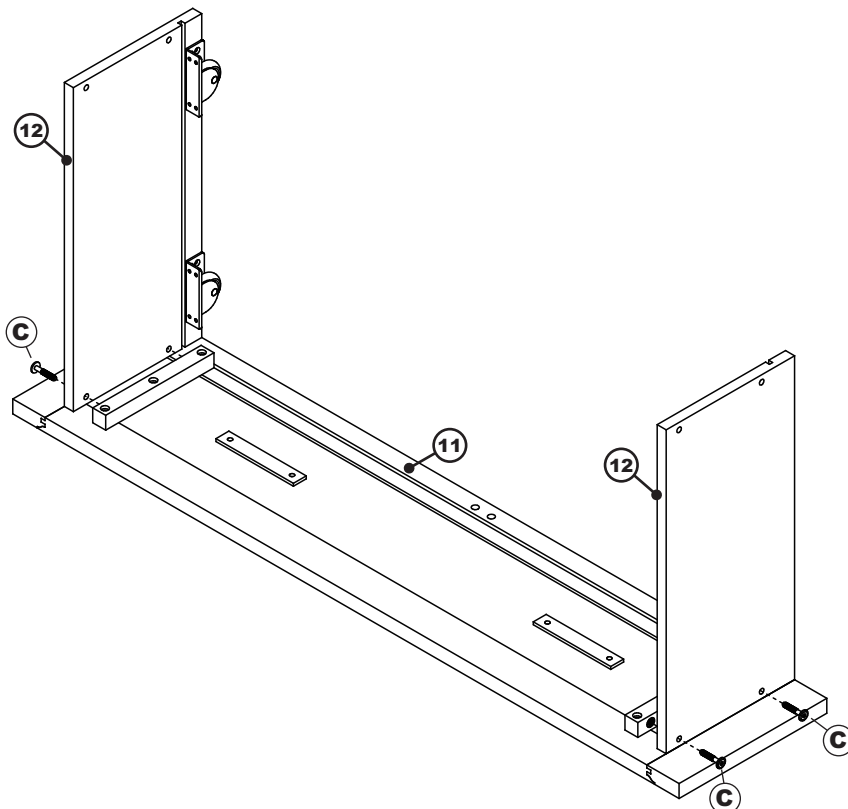

TWIN XL

STEP 12

Guide the drawer panel (14) in carefully so that it won't jump out of its grooves. Be sure it fits fully into its groove at the bottom (in the drawer face) before fitting the drawer back. Attach drawer panel support (15) to the drawer face as shown below.

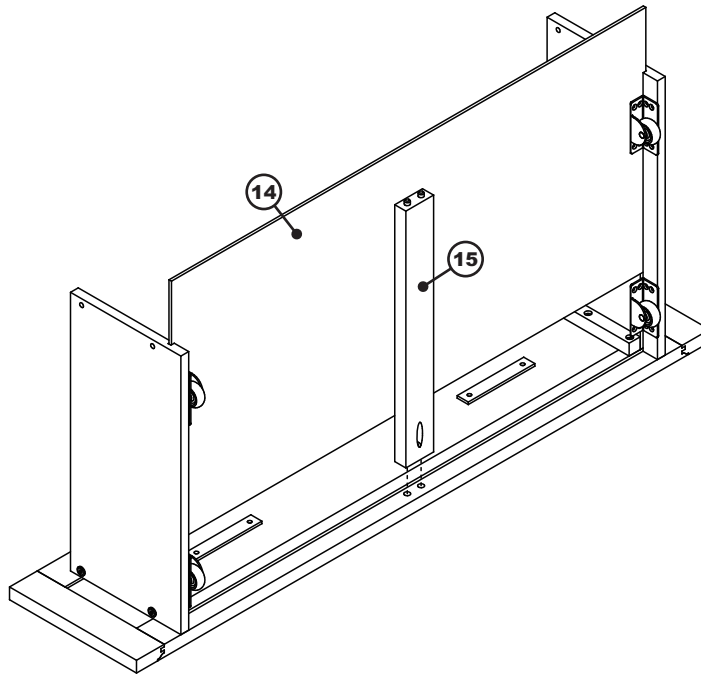

Adult assembly

STEP 13

Attach drawer back (13) and drawer side block (16) to bed drawer assembly as shown below. Use JCB (C)(D). Tighten with Allen wrench (H). Use wood screw (G) tighten with Phillips head screwdriver (customer supplied).

Phillips screwdriver



Customer supplied

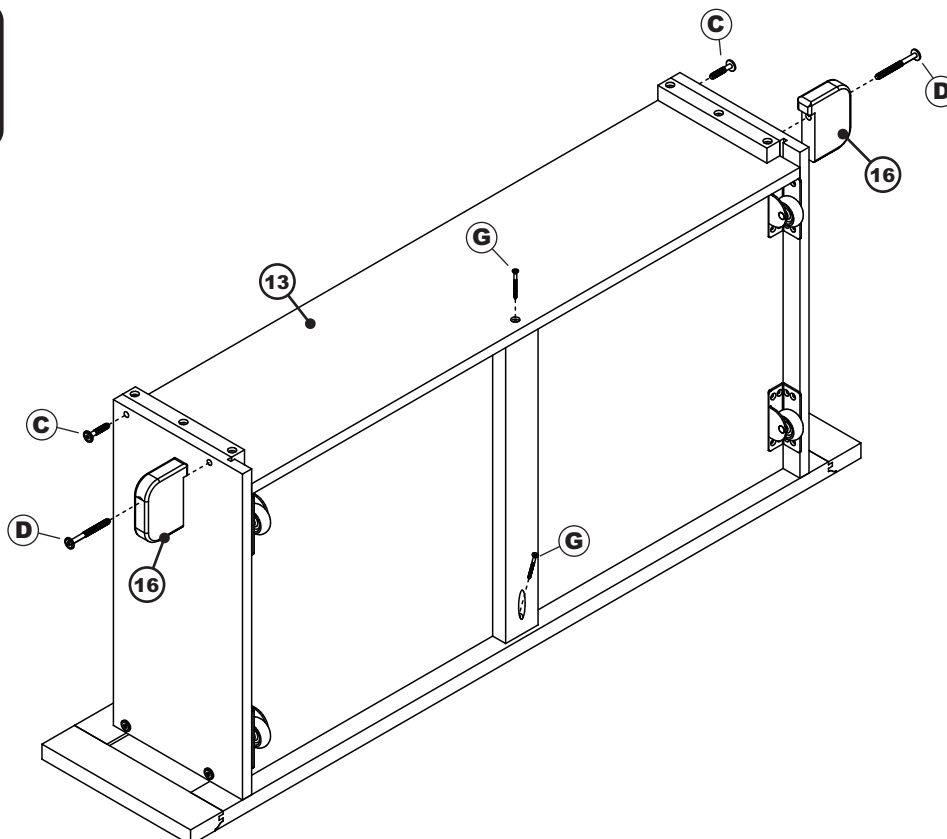

Adult assembly



1 1/4"
JCB M6 X 30mm



2 3/8"
JCB M6 X 60mm



Wood screw 1 1/2"



Allen wrench

TWIN XL

STEP 14

Move the murphy bed where you want to place them in the room. Push drawer assembly in as shown below. Be sure to align with cabinet.

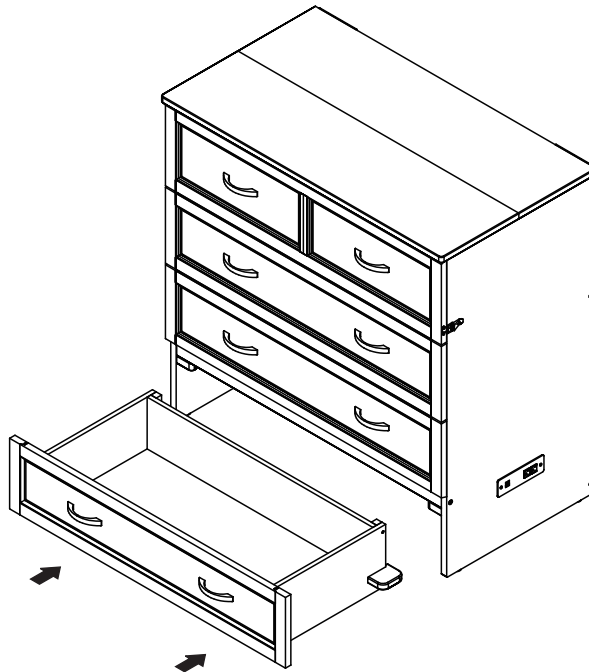

STEP 15

Unlatch the door and open top drawer folding leg until lock of metal support, folding down as shown.

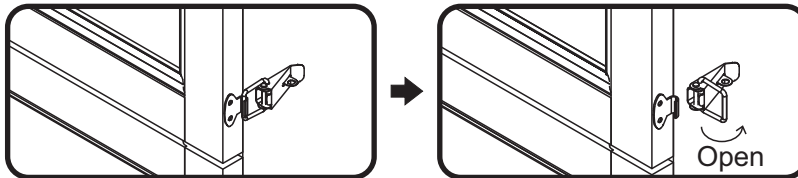

TOP DRAWER FOLDING LEG

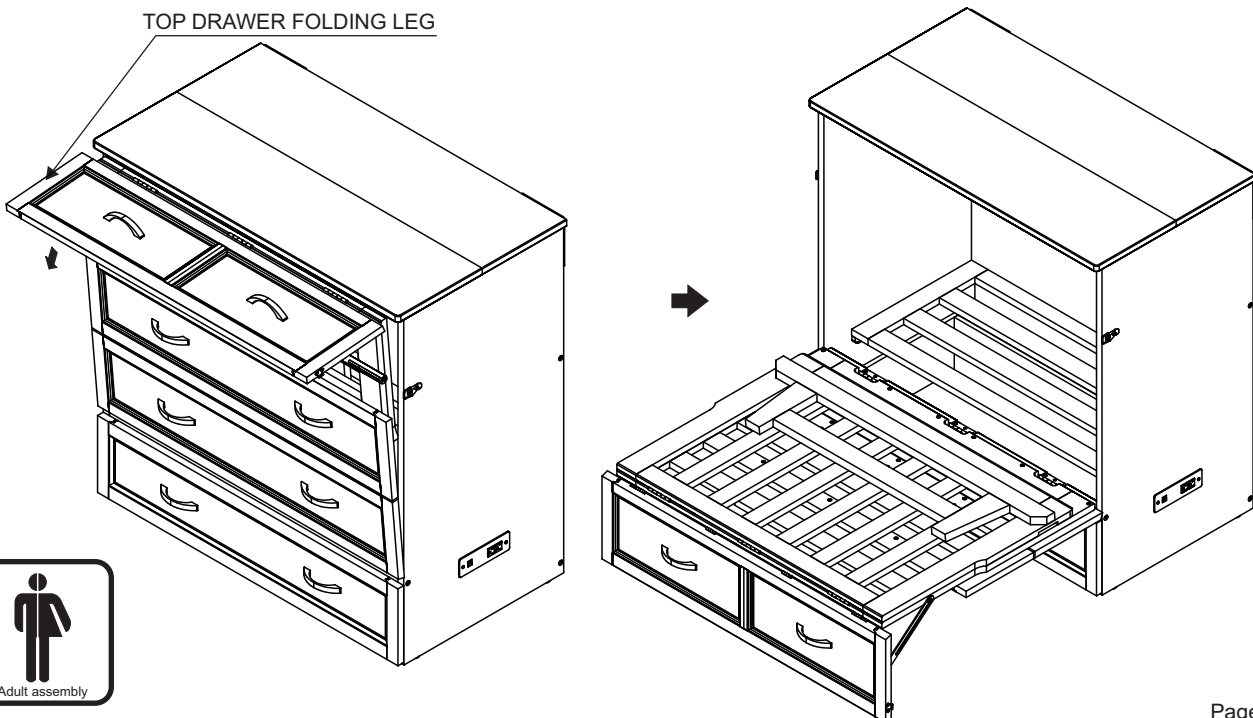

TWIN XL

STEP 16 Open and pull footboard frame and open footboard leg as shown below.

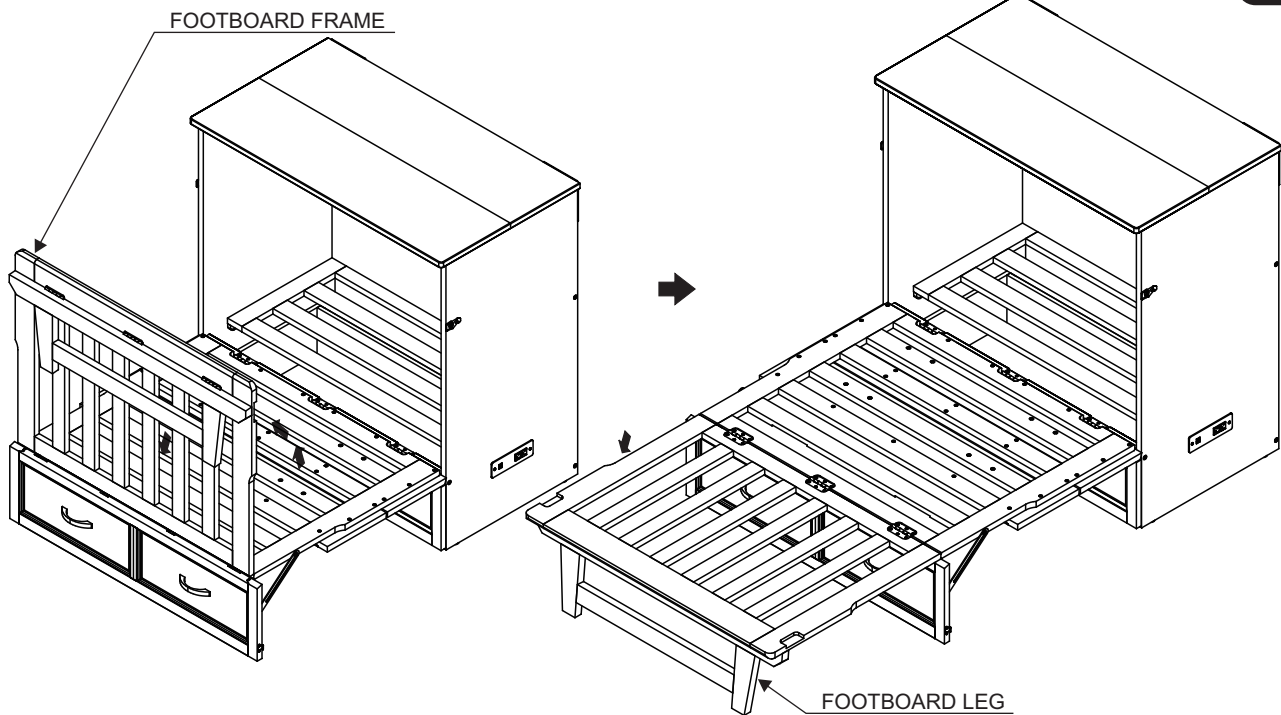

STEP 17 Install folding mattress (17) to the bed. Open top panel as shown below.

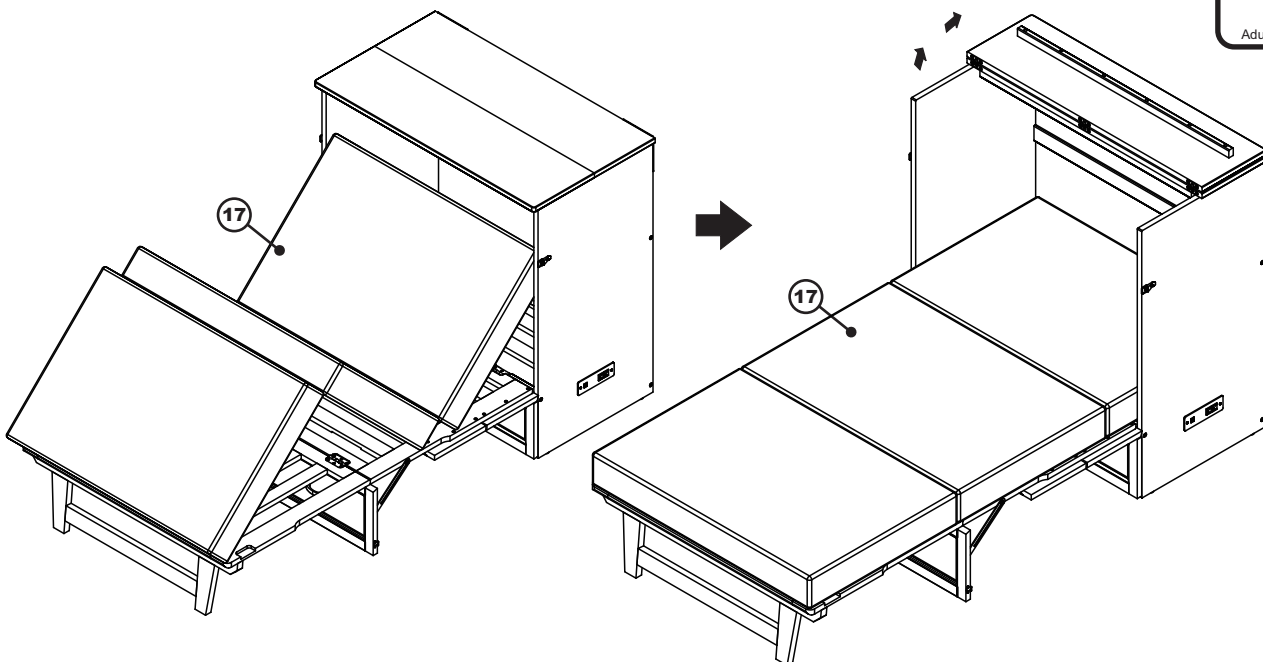

Congratulations!

Your Murphy bed is now ready for use.

We recommend that you recheck that all screws are tight, and that all parts are secure before use to ensure lasting Safety.