

## ASSEMBLY INSTRUCTIONS

Before assembling your headboard, please read through these instructions carefully and familiarize yourself with the different parts.

**ATTENTION!** If you receive a damaged or defective item, please contact afifurnishings at [customerservice@afifurnishings.com](mailto:customerservice@afifurnishings.com) or 1-800-955-3726



### PARTS LIST

①	LEFT POST	1 PC
②	RIGHT POST	1 PC
③	HB TOP RAIL	1 PC
④	MID RAIL	1 PC
⑤	HB BOTTOM RAIL	1 PC
⑥	FOOTBOARD PANEL	1 PC
⑦	LEFT LEG	1 PC
⑧	RIGHT LEG	1 PC
⑨	FB TOP RAIL	1 PC
⑩	FB BOTTOM RAIL	1 PC

Instructions apply for bed sizes  
**FULL > QUEEN**

### HARDWARE

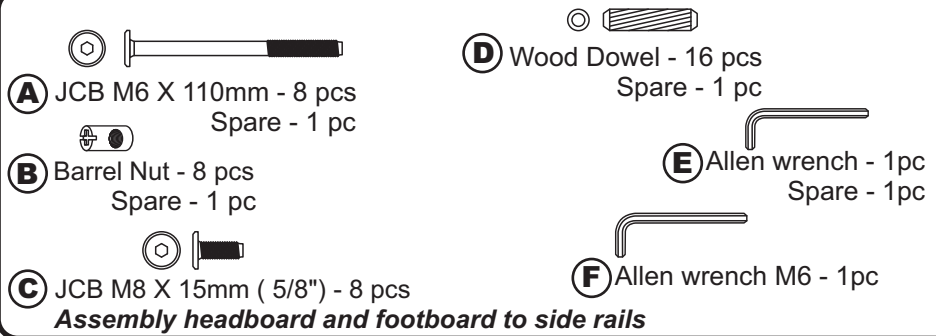

NOTE: WE INCLUDE SPARE HARDWARE IN CASE DAMAGE OCCURS DURING ASSEMBLY.

### Step 1

Insert all wooden dowels (D) into the locator holes on (3)(4)(5)(9) and(10) as shown below.

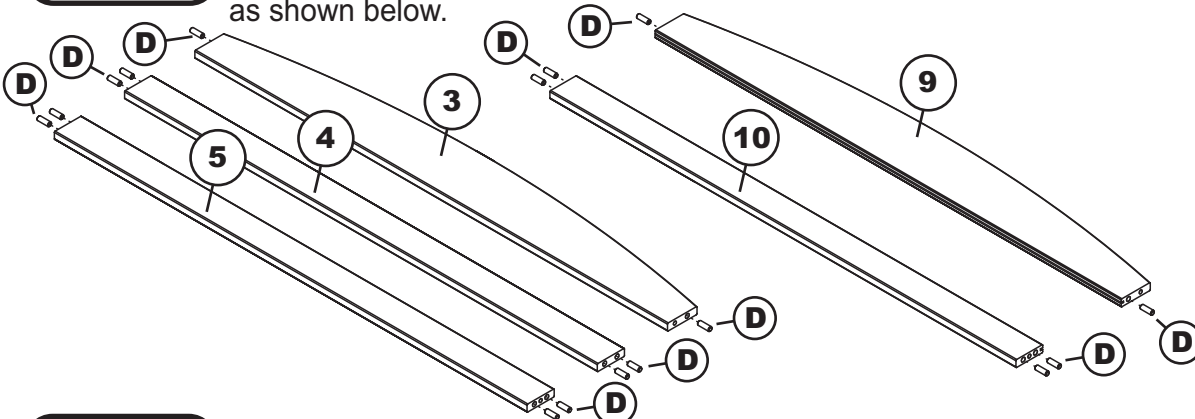

Adult assembly

**(D)**



Wood Dowel

### Step 2

Lay the left and right post (1)(2) bracket face down on smooth surface. Connect HB top rail (3), mid rail (4) and HB bottom rail (5) as shown below, using JCB M6 X 110mm (A) and barrel nut (B). Tighten with the Allen wrench (E).

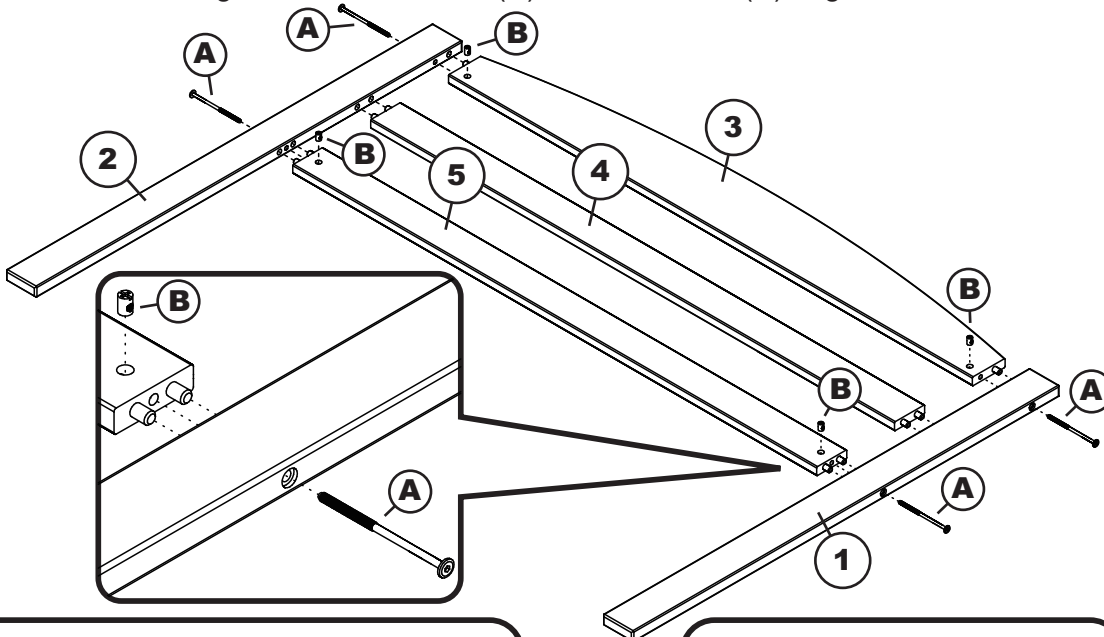

Adult assembly

**(A)**



JCB M6 X 110mm

**(B)**



Barrel Nut

PO:

CODE	ITEM	ITEM
HBFB-ISL-WRN	G-12903X	G-12904X

**Step 3**

Lay the left leg (7) bracket face up on smooth surface. Connect FB top rail (9) and FB bottom rail (10) as shown below, using JCB M6 X 110mm (A) and barrel nut (B). Tighten with the Allen wrench (E).

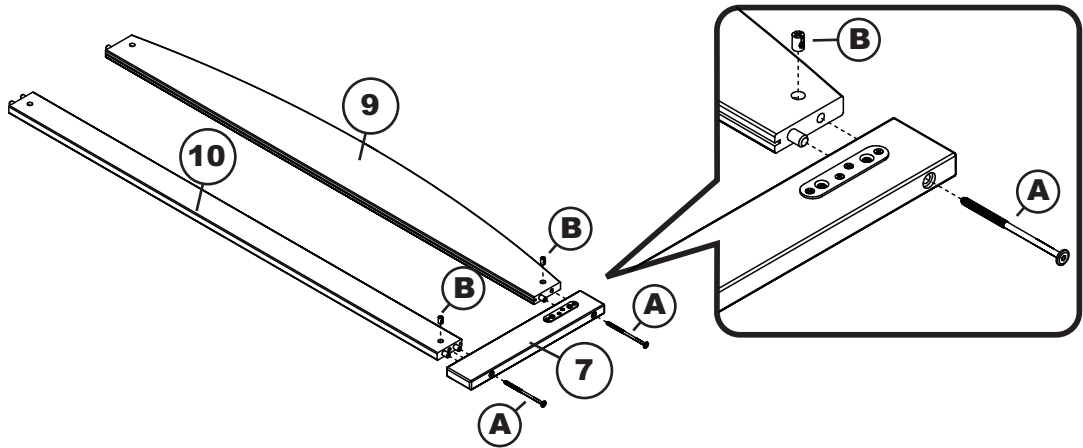
**Step 4**

Guide the footboard panel (6) in carefully so that it won't jump out of its grooves. Be sure it fits fully into the groove at the end (in the leg) before fitting the other leg.

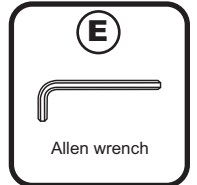
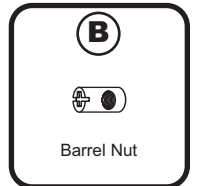
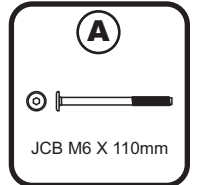
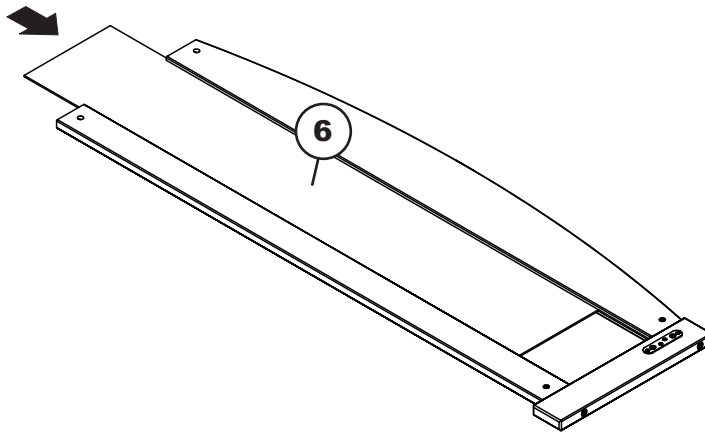
**Step 5**

Attach the right leg (8) to footboard assembly as shown below, using JCB M6 X 110mm (A) and barrel nut (B). Tighten with Allen wrench (E)

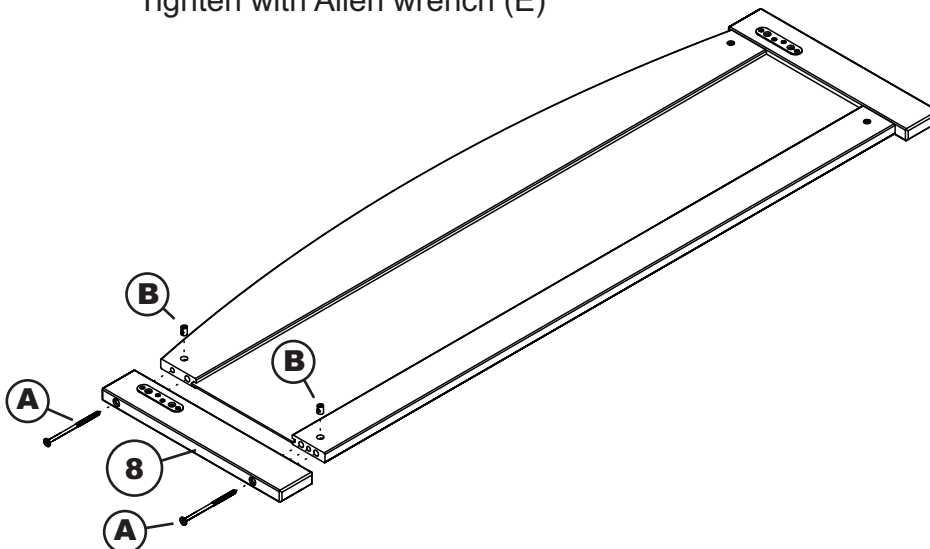

FULL > QUEEN

- 01 HARDWARE
  - 02 HEADBOARD
  - 03 FOOTBOARD
- BOX 1

- 01 HARDWARE
  - 04 SIDE RAILS
  - 05 SLAT KIT
- BOX 2

**Step 1**

Attach the side rails (04) to the headboard (02) and footboard (03) using JCB M8 X 15mm (C). Tighten with Allen wrench M6 (F).

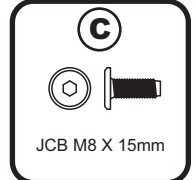
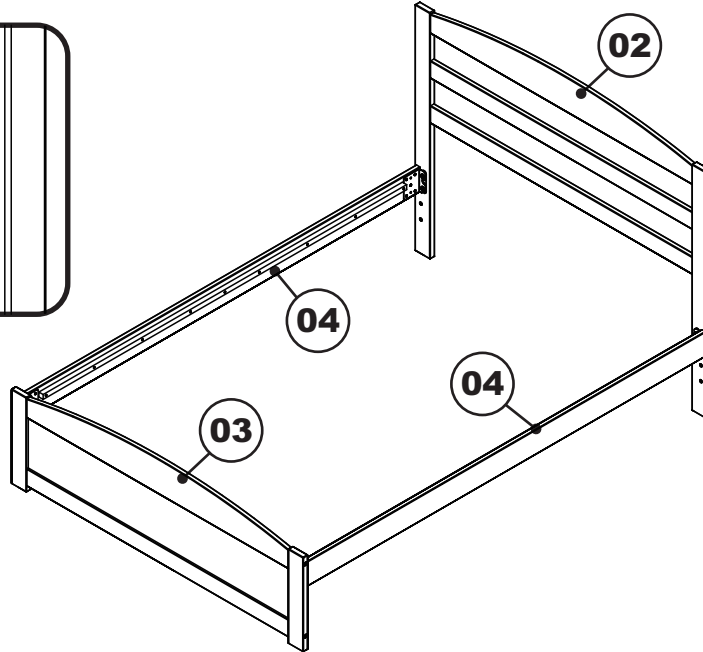
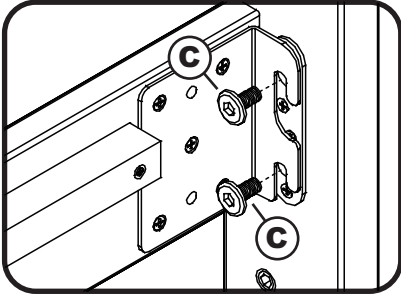

**Step 2**

Attach slat kit (05) onto the bed using wood screws. Tighten with Phillips head screw driver. (customer supplied) For assembly of slat kit, follow the assembly instructions included with bed frame.

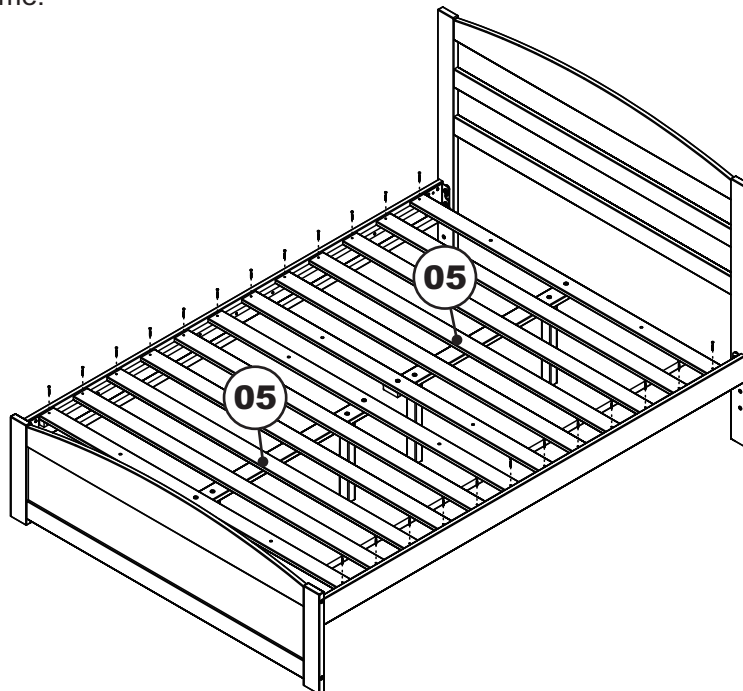

**Congratulations!**

Your bed is now ready for use.

We recommend that you periodically recheck that all screws are tight to ensure lasting safety.

## QUEEN ASSEMBLY INSTRUCTIONS

Before assembling your bed frame, please read through these instructions carefully and familiarize yourself with the different parts.



**ATTENTION!** If you receive a damaged or defective item, please contact [afifurnishings.com](mailto:customerservice@afifurnishings.com) at [customerservice@afifurnishings.com](mailto:customerservice@afifurnishings.com) or 1-800-955-3726

### PARTS LIST

- |   |                         |               |
|---|-------------------------|---------------|
| 1 | <b>SIDE RAIL</b>        | <b>2 PCS</b>  |
| 2 | <b>SLAT KIT</b>         | <b>2 SETS</b> |
| 3 | <b>SLAT SUPPORT</b>     | <b>2 PCS</b>  |
| 4 | <b>SLAT SUPPORT LEG</b> | <b>4 PCS</b>  |

- |          |  |          |                                      |                 |                                     |
|----------|--|----------|--------------------------------------|-----------------|-------------------------------------|
| <b>A</b> | Wood screw (1 1/4") - 12 pcs<br>Spare - 1 pc | <b>D</b> | JCB M8 X 40mm - 4 pcs                | <b>HARDWARE</b> |                                     |
| <b>B</b> | JCB M6 X 30mm - 6 pcs                        | <b>E</b> | Split washer - 4 pcs<br>Spare - 1 pc | <b>F</b>        | Flat washer - 4 pcs<br>Spare - 1 pc |
| <b>C</b> | Cap nut - 6 pcs                              |          |                                      |                 |                                     |

NOTE: WE INCLUDE SPARE HARDWARE IN CASE DAMAGE OCCURS DURING ASSEMBLY.

### Step 1

Attach side rails (1) to the headboard and footboard. For assembly, follow the assembly instructions included with your headboard and footboard.

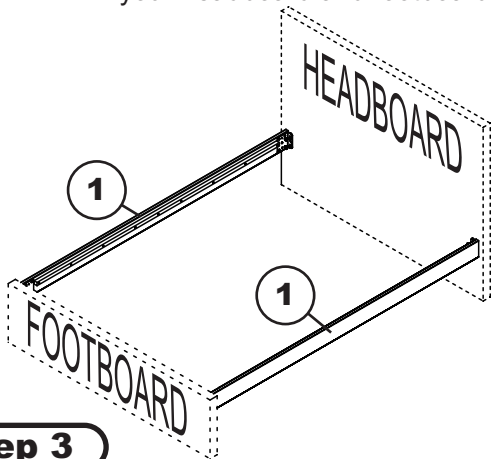

### Step 2

Attach slat support legs (4) to slat support (3) as shown below using JCB M8 X 40mm (D) split and flat washer (E)(F) tighten with Allen wrench M6.

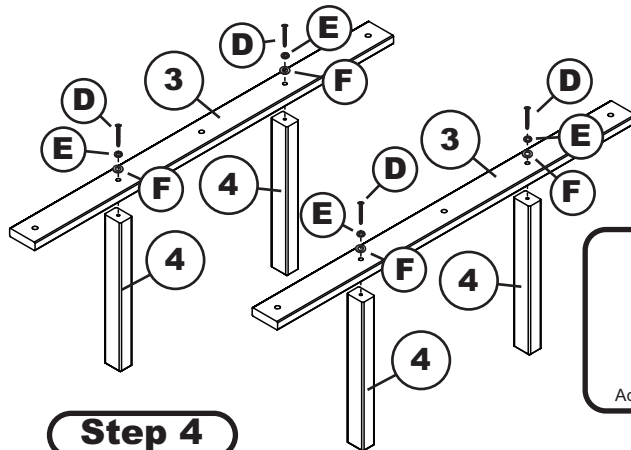

### Step 3

Attach slat support (3) to the slat kit (2) as shown below using JCB M6 X 30mm (B) and cap nut (C). Tighten with Allen wrench M4.

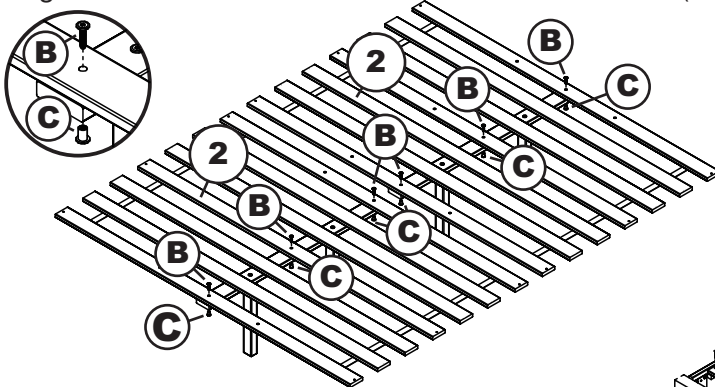

### Step 4

Attach the slat kit (2) onto the bed using wood screws 1 1/4" (A). Tighten with Phillips head screw driver. (customer supplied)

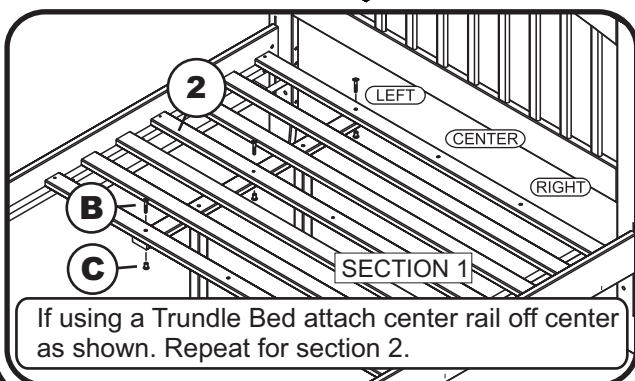
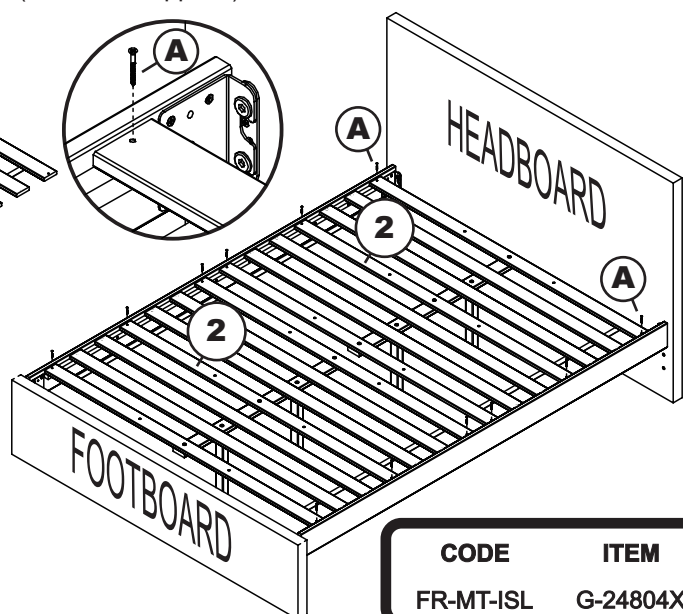

If using a Trundle Bed attach center rail off center as shown. Repeat for section 2.

CODE	ITEM
FR-MT-ISL	G-24804X

**PO:**