

ASSEMBLY INSTRUCTIONS

Before assembling your headboard, please read through these instructions carefully and familiarize yourself with the different parts.

ATTENTION! If you receive a damaged or defective item, please contact afifurnishings at customerservice@afifurnishings.com or 1-800-955-3726



PARTS LIST

- ① LEFT POST 1 PC
- ② RIGHT POST 1 PC
- ③ TOP RAIL 1 PC
- ④ MID RAIL 1 PC
- ⑥ BOTTOM RAIL 1 PC

Instructions apply for bed sizes
TWIN > FULL > QUEEN

HARDWARE

- Ⓐ JCB M6 X 110mm - 4 pcs
Spare - 1 pc
- Ⓑ Barrel Nut - 4 pcs
Spare - 1 pc
- Ⓒ JCB M8 X 15mm (5/8") - 4 pcs
Assembly headboard to open bed frame
- Ⓓ Wood Dowel - 10 pcs
Spare - 1 pc
- Ⓔ Allen wrench - 1pc
Spare - 1pc

- HARDWARE FOR METAL BED FRAME
- Ⓕ JCB M6 X 25mm (1") - 4 pcs
Spare - 1 pc
 - Ⓖ Flat washer - 4 pcs
Spare - 1 pc
 - Ⓗ Split washer - 4 pcs
Spare - 1 pc

NOTE: WE INCLUDE SPARE HARDWARE IN CASE DAMAGE OCCURS DURING ASSEMBLY.

Step 1

Insert all wooden dowels (D) into the locator holes on (3)(4) and(5) as shown below.

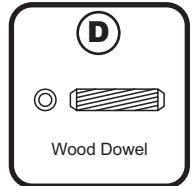
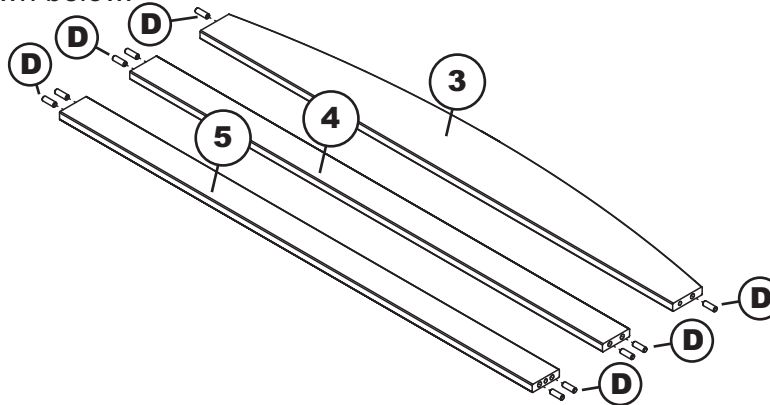

Step 2

Lay the left post (1) bracket face down on smooth surface. Connect top rail (3), mid rail (4) and bottom rail (5) as shown below, using JCB M6 X 110mm (A) and barrel nut (B). Tighten with the Allen wrench (E).

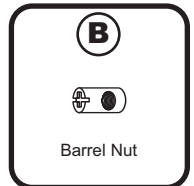
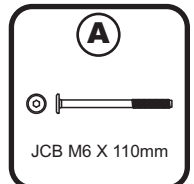
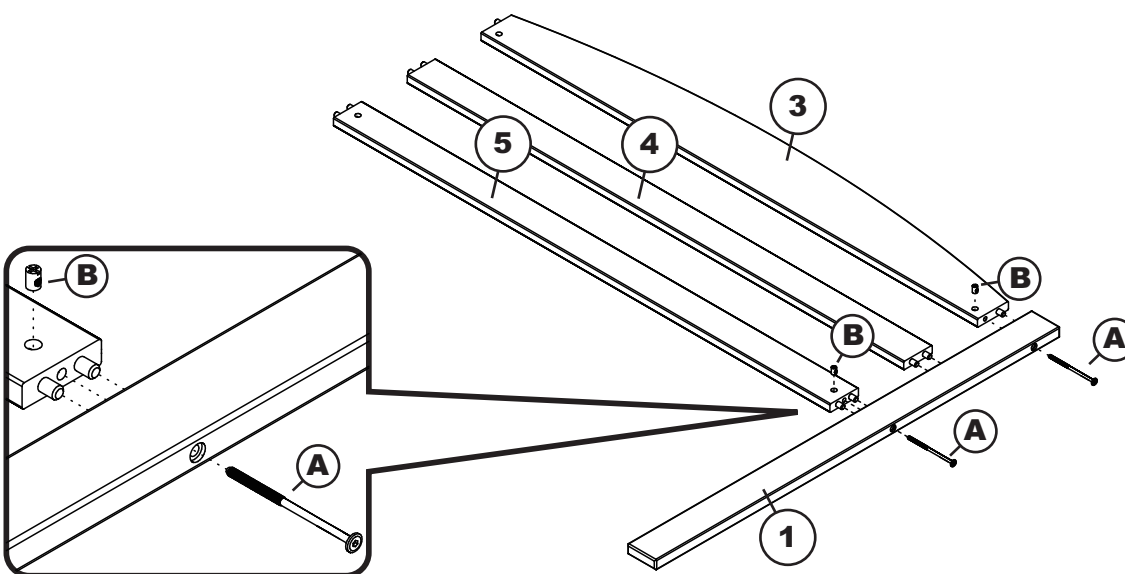

PO:

CODE	ITEM	ITEM	ITEM
HB-ISL-WRN	G-11902X	G-11903X	G-11904X

Step 3

Attach the right post (2) to headboard assembly as shown below, using JCB M6 X 110mm (A) and barrel nut (B). Tighten with Allen wrench (E)

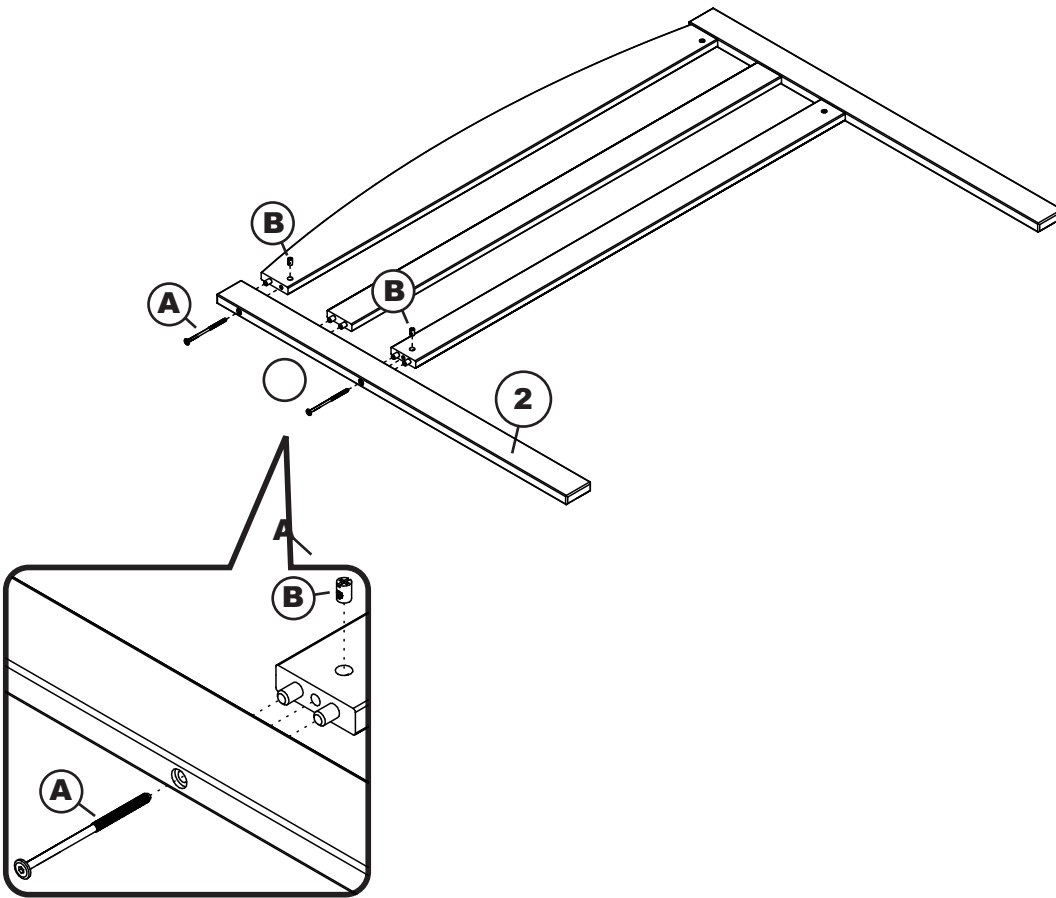

Adult assembly

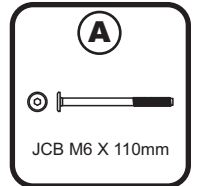

JCB M6 X 110mm

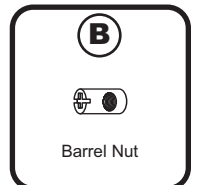

Barrel Nut

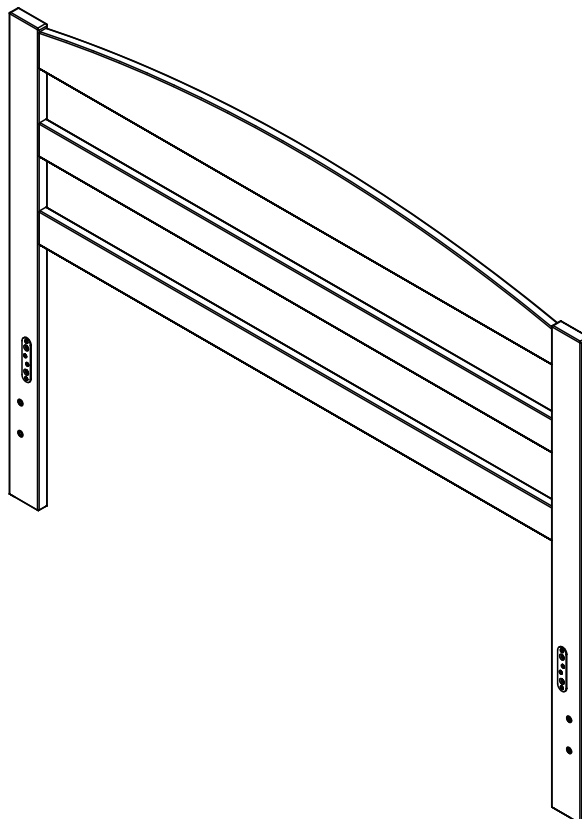

FOR BED FRAME ASSEMBLY follow assembly instructions included with your bed frame.
If you purchased a wood headboard to attach to metal bed frame, please refer to page 3.

TWIN>TWIN XL ASSEMBLY INSTRUCTIONS

Before assembling your bed frame, please read through these instructions carefully and familiarize yourself with the different parts.



ATTENTION! If you receive a damaged or defective item, please contact afifurnishings at customerservice@afifurnishings.com or 1-800-955-3726

PARTS LIST

- ① **FOOT RAIL** 1 PC
- ② **LEFT LEG** 1 PC
- ③ **RIGHT LEG** 1 PC
- ④ **SIDE RAIL** 2 PCS
- ⑤ **SLAT KIT** 2 SETS

HARDWARE

- Ⓐ JCB M6 X 110mm (4 3/8") - 2 pcs
Spare - 1 pc
- Ⓑ Barrel nut - 2 pcs
- Ⓒ JCB M8 X 15mm (5/8") - 4 pcs
- Ⓓ Wood screw(1 1/4") - 24 pcs
Spare - 2 pcs
- Ⓔ Allen wrench M6 - 1pc
- Ⓕ Allen wrench M4 - 1pc
Spare - 1pc

NOTE: WE INCLUDE SPARE HARDWARE IN CASE DAMAGE OCCURS DURING ASSEMBLY.

Step 1

Attach the legs (2) and (3) to foot rail (1), using JCB M6 X 110mm (A) and barrel nut (B).
Tighten with the Allen wrench M4 (F).

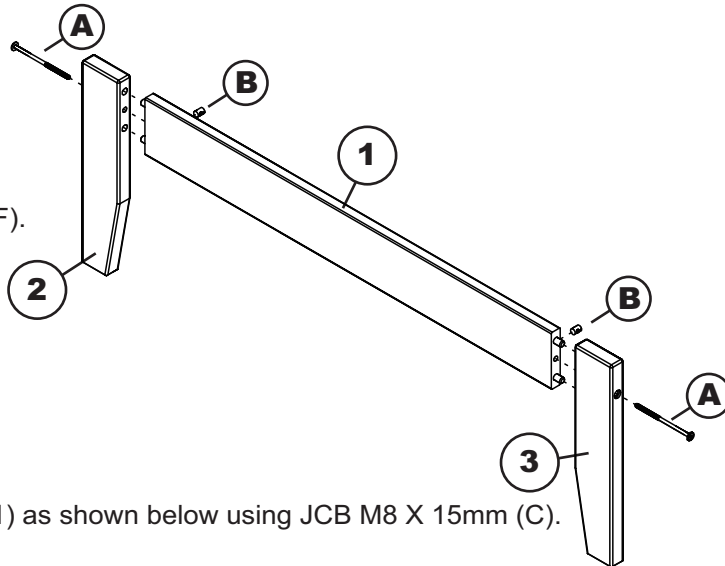

Adult assembly

Ⓐ



JCB M6 X 110mm

Ⓑ



Barrel nut

Step 2

Attach side rails (4) to the foot rail (1) as shown below using JCB M8 X 15mm (C).
Tighten with Allen wrench M6 (E).

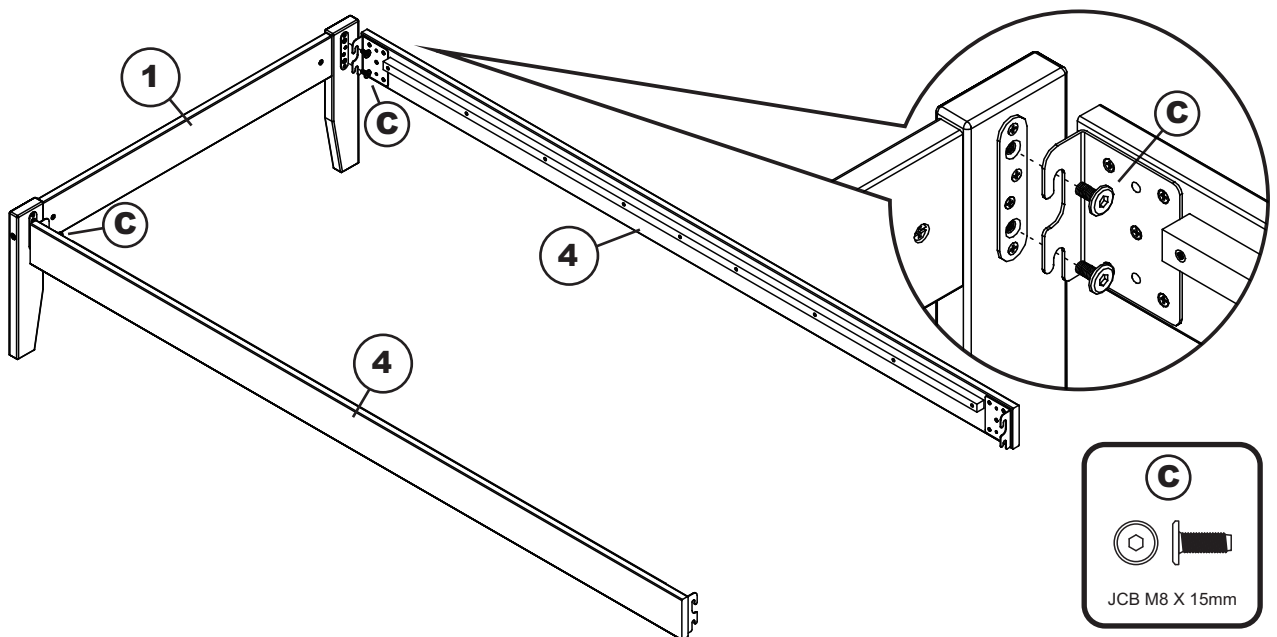

Ⓒ



JCB M8 X 15mm

PO:

CODE	ITEM	ITEM
FR-OP-ISL	G-21801X	G-21802X

Step 3

Attach open bed frame to the headboard as shown below using 4 JCB M8 X 15mm bolts that are supplied with your headboard. Tighten with the Allen wrench M6 (E).

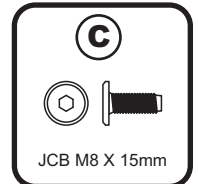
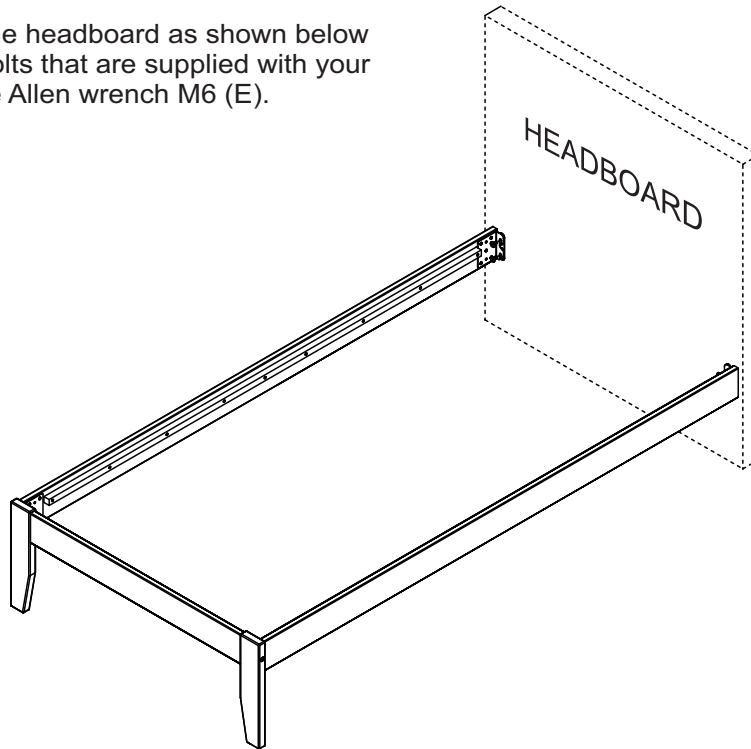

Step 4

Attach 2 slat kit (5) to the open bed as shown below using wood screws 1 1/4" (D). Tighten with Phillips head screw driver. (customer supplied)

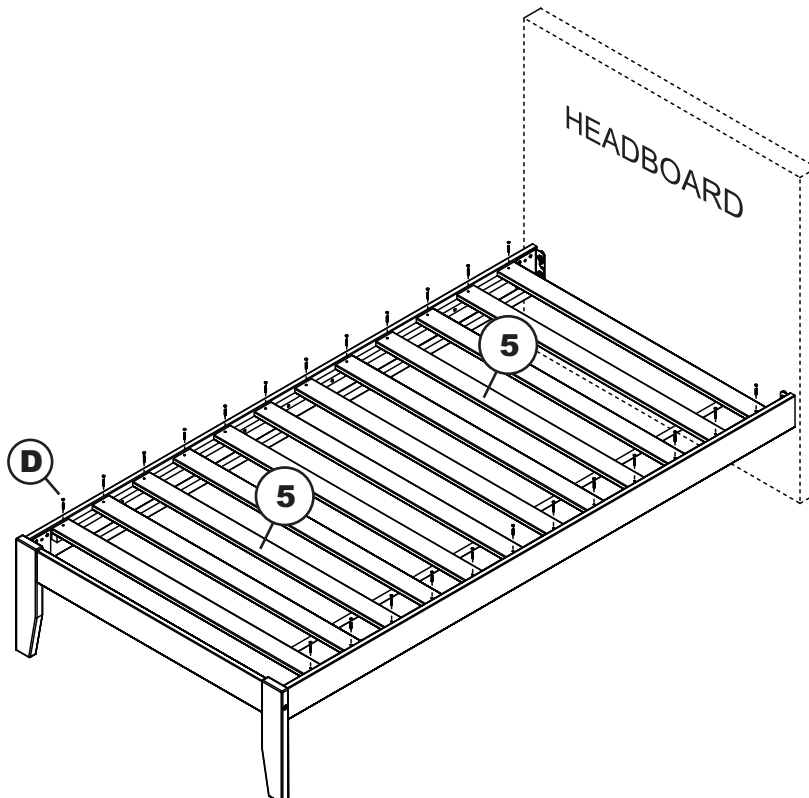

Congratulations!

Your bed is now ready for use.

We recommend that you periodically recheck that all screws are tight to ensure lasting safety.

TWIN XL

ASSEMBLY INSTRUCTIONS

Before assembling your Trundle bed, please read through these instructions carefully. Familiarize yourself with the different parts.



ATTENTION! If you receive a damaged or defective item, please contact afifurnishings at customerservice@afifurnishings.com or 1-800-955-3726

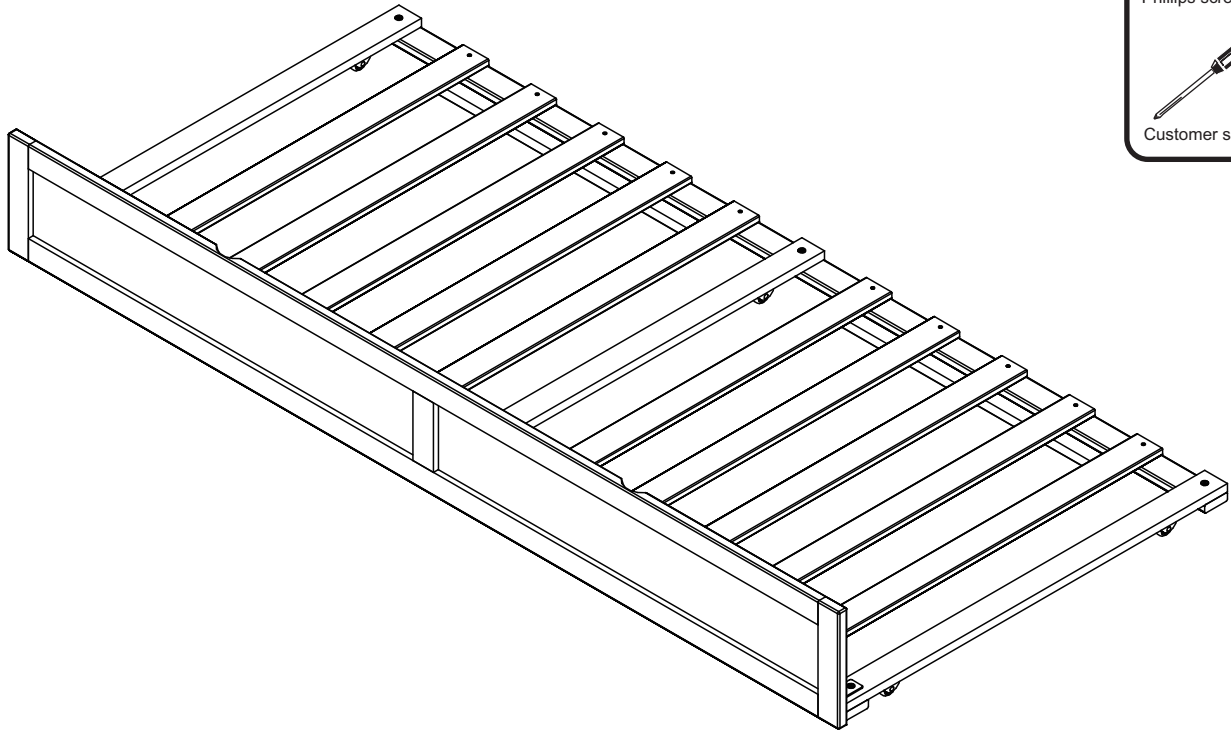

CODE	ITEM
ST-TD-ISL	G-35801X

PO :

HARDWARE

NOTE: WE INCLUDE SPARE HARDWARE IN CASE DAMAGE OCCURS DURING ASSEMBLY.

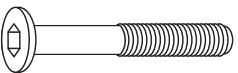
A  JCB M6 X 1 5/8" (40mm) - 9 pcs
Spare - 1 pc

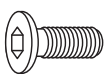
B  JCB M6 X 5/8" (15mm) - 6 pcs
Spare - 1 pc
Fix L bracket to front panel

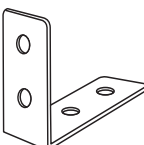
C  L Bracket - 3 pcs

D  Wood screw - 20 pcs
Spare - 2 pcs

E  Allen wrench - 1 pc
Spare - 1 pc

TWIN XL

PARTS LIST

- | | | | | | |
|----|-------------|-------|----|-----------------------|--------|
| 01 | HARDWARE | 1 BOX | 05 | LEFT, RIGHT, MID RAIL | 3 PCS |
| 02 | FRONT PANEL | 1 PC | 06 | SLAT KIT WITH WEBBING | 2 SETS |
| 03 | FRONT RAIL | 1 PC | | | |
| 04 | BACK RAIL | 1 PC | | | |

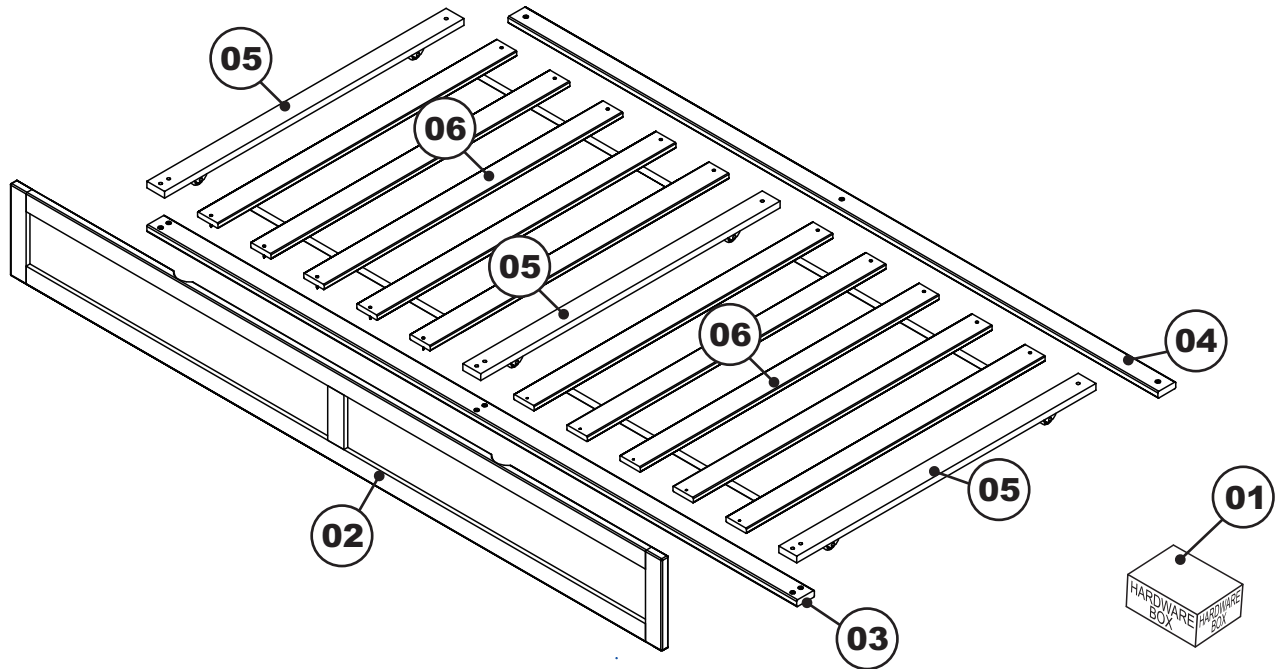

Step 1

Attach the left, right and mid rails (05) to the front rail (03) using L bracket (C) and JCB M6 X 1 5/8" (A). Attach left, right and mid rails (05) to the back rail (04) using JCB M6 X 1 5/8" (A). Tighten with the Allen wrench (E).

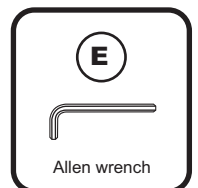
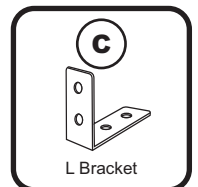
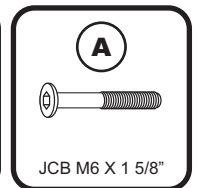
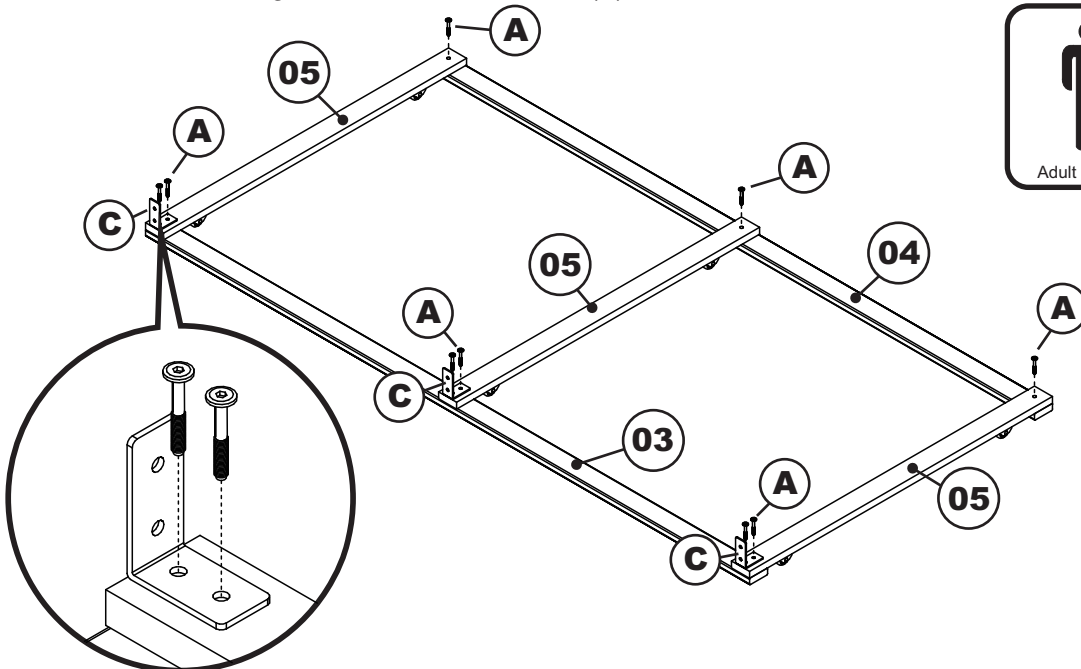

TWIN XL

Step 2

Attach the front panel (02) to the front rail (03) as shown, using JCB M6 X 5/8" (B). Tighten with the Allen wrench (E).

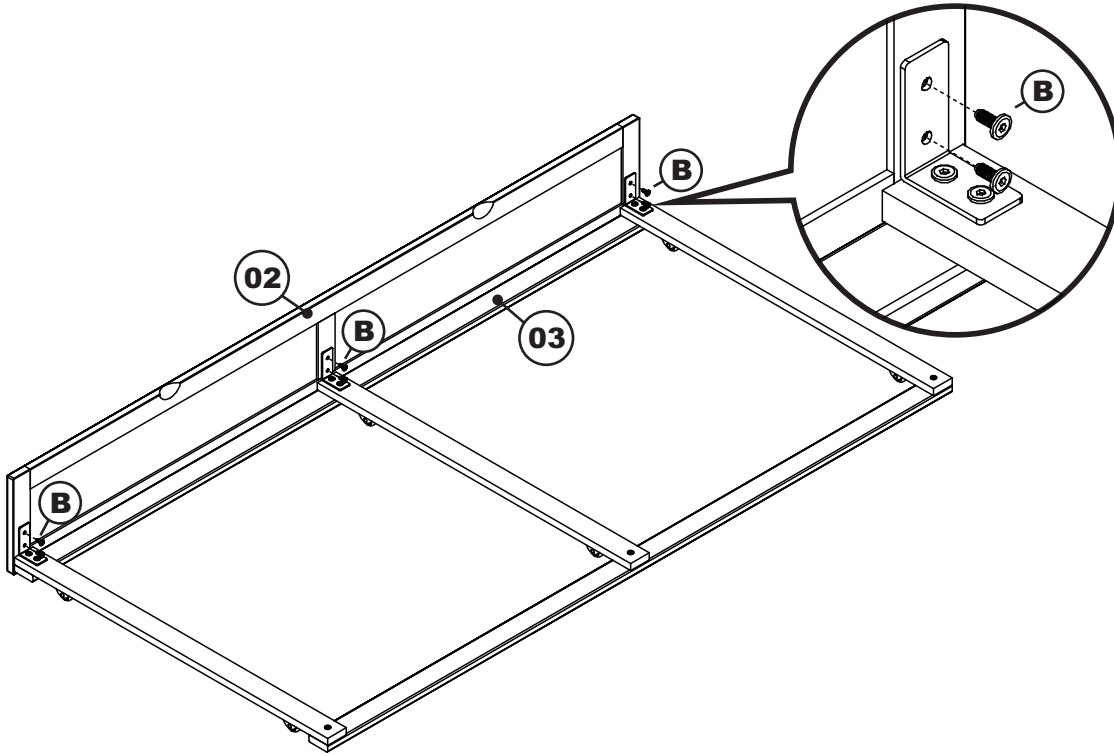

Adult assembly

B



JCB M6 X 5/8"

E



Allen wrench

Step 3

Lay the slat kits (06) webbing side down onto the rail assembly as shown. Attach using wood screw (D) and tighten with the Phillips head screw driver. (customer supplied)

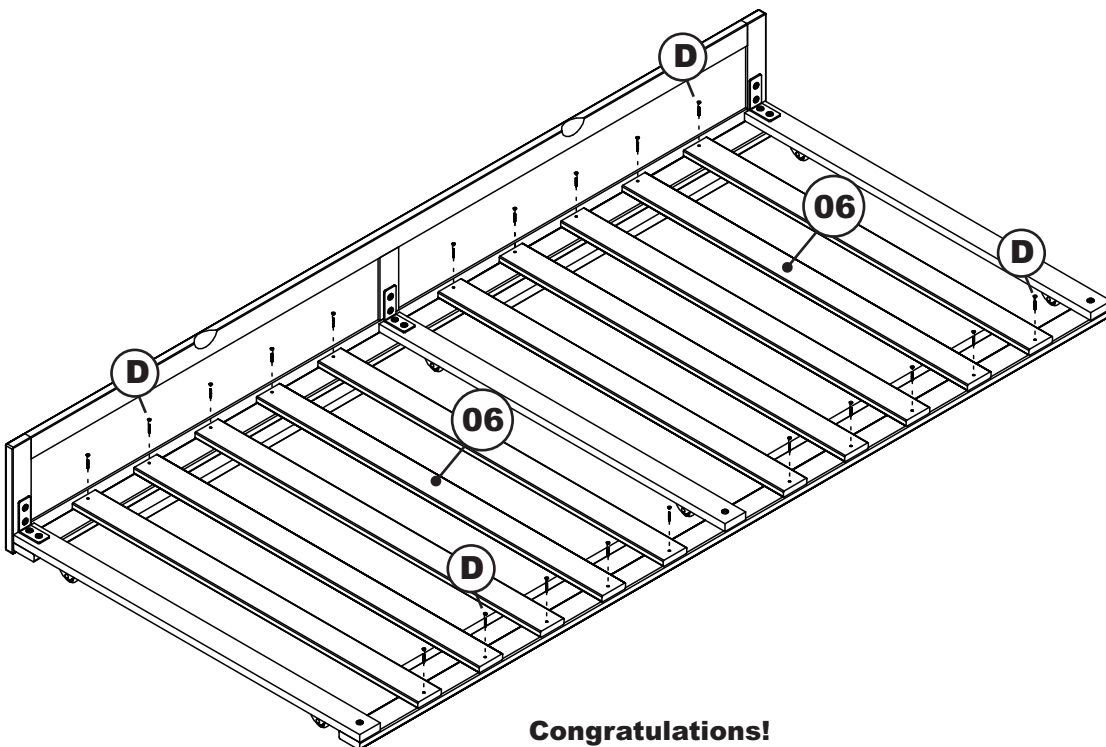

Adult assembly

D

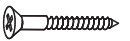

Wood screw

Phillips screwdriver



Customer supplied

Congratulations!

Your Trundle bed is now ready for use.

We recommend that you periodically check that all screws are tight and all parts are secure to ensure lasting safety.