

## ASSEMBLY INSTRUCTIONS

Before assembling your headboard, please read through these instructions carefully and familiarize yourself with the different parts.

**ATTENTION!** If you receive a damaged or defective item, please contact afifurnishings at [customerservice@afifurnishings.com](mailto:customerservice@afifurnishings.com) or 1-800-955-3726



### PARTS LIST

- ① HEADBOARD PANEL 2 PCS
- ② LEFT POST 1 PC
- ③ RIGHT POST 1 PC
- ④ HB TOP RAIL 1 PC
- ⑤ MID RAIL 1 PC
- ⑥ HB BOTTOM RAIL 1 PC
- ⑦ FOOTBOARD PANEL 1 PC
- ⑧ LEFT LEG 1 PC
- ⑨ RIGHT LEG 1 PC
- ⑩ FB TOP RAIL 1 PC
- ⑪ FB BOTTOM RAIL 1 PC

Instructions apply for bed sizes  
**TWIN**

### HARDWARE

- ① JCB M6 X 110mm - 8 pcs  
Spare - 1 pc
- ② Barrel Nut - 8 pcs  
Spare - 1 pc
- ③ JCB M8 X 15mm ( 5/8" ) - 8 pcs  
*Assembly headboard and footboard to side rails*
- ④ Wood Dowel - 16 pcs  
Spare - 1 pc
- ⑤ Allen wrench - 1pc  
Spare - 1pc
- ⑥ Allen wrench M6 - 1pc

NOTE: WE INCLUDE SPARE HARDWARE IN CASE DAMAGE OCCURS DURING ASSEMBLY.

### Step 1

Insert all wooden dowels (D) into the locator holes on (4)(5)(6)(10) and(11) as shown below.

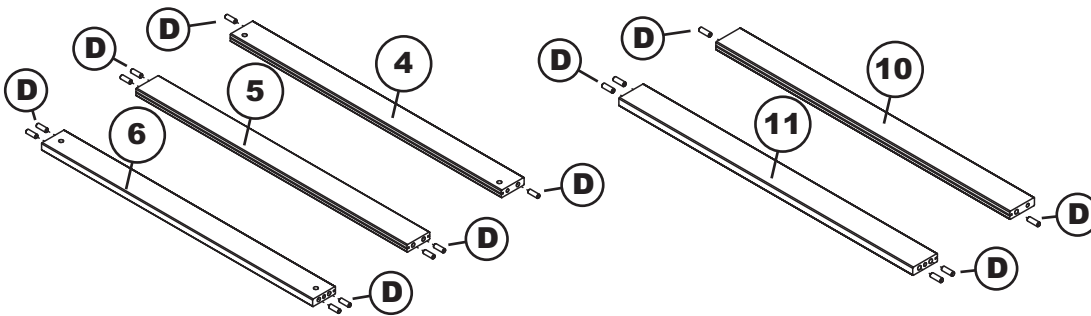

Adult assembly

④



Wood Dowel

### Step 2

Lay the left post (2) bracket face down on smooth surface. Connect HB top rail (4), mid rail (5) and HB bottom rail (6) as shown below, using JCB M6 X 110mm (A) and barrel nut (B). Tighten with the Allen wrench (E).

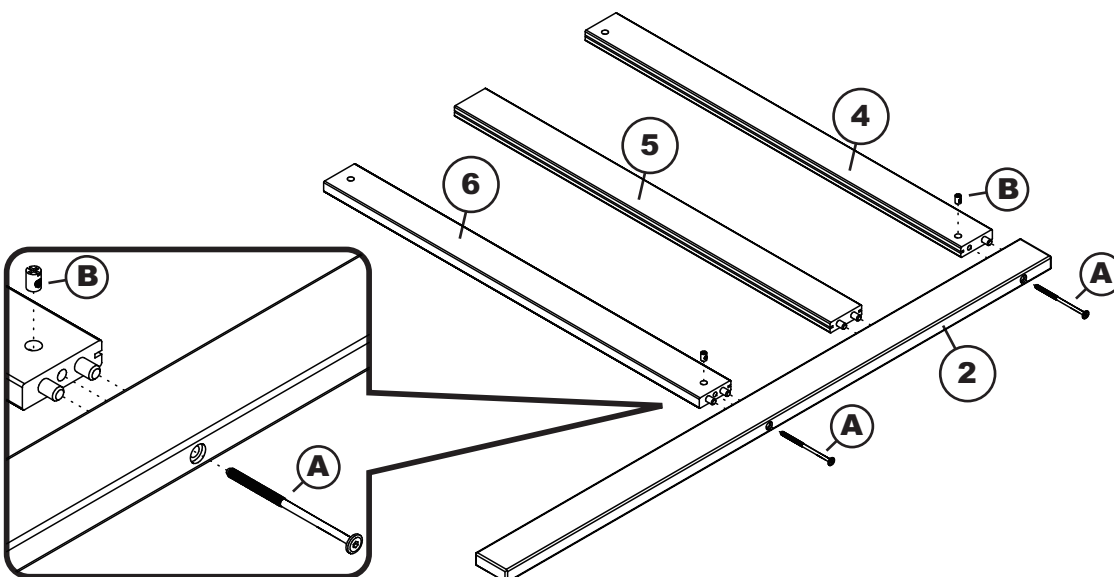

Adult assembly

①

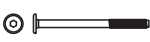

JCB M6 X 110mm

②



Barrel Nut

PO:

CODE  
HBFB-ISL-NOHO

ITEM  
G-12912X

**Step 3**

Guide the headboard panel (1) in carefully so that it won't jump out of its grooves. Be sure it fits fully into the groove at the end (in the post) before fitting the other post.

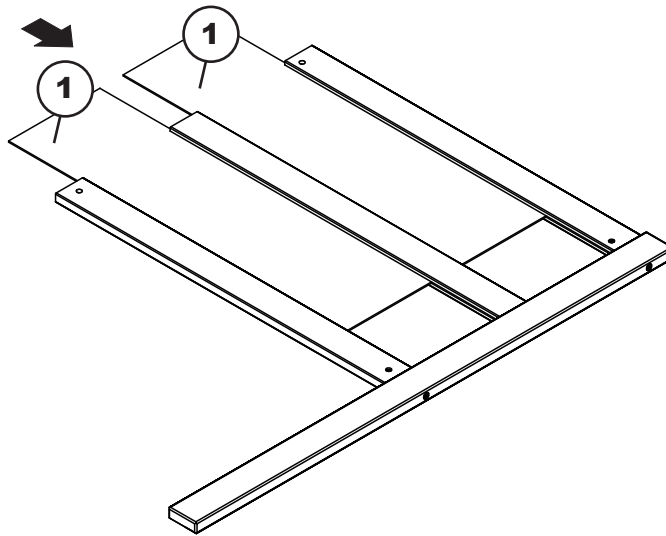

**Step 4**

Attach the right post (3) to headboard assembly as shown below, using JCB M6 X 110mm (A) and barrel nut (B). Tighten with Allen wrench (E)

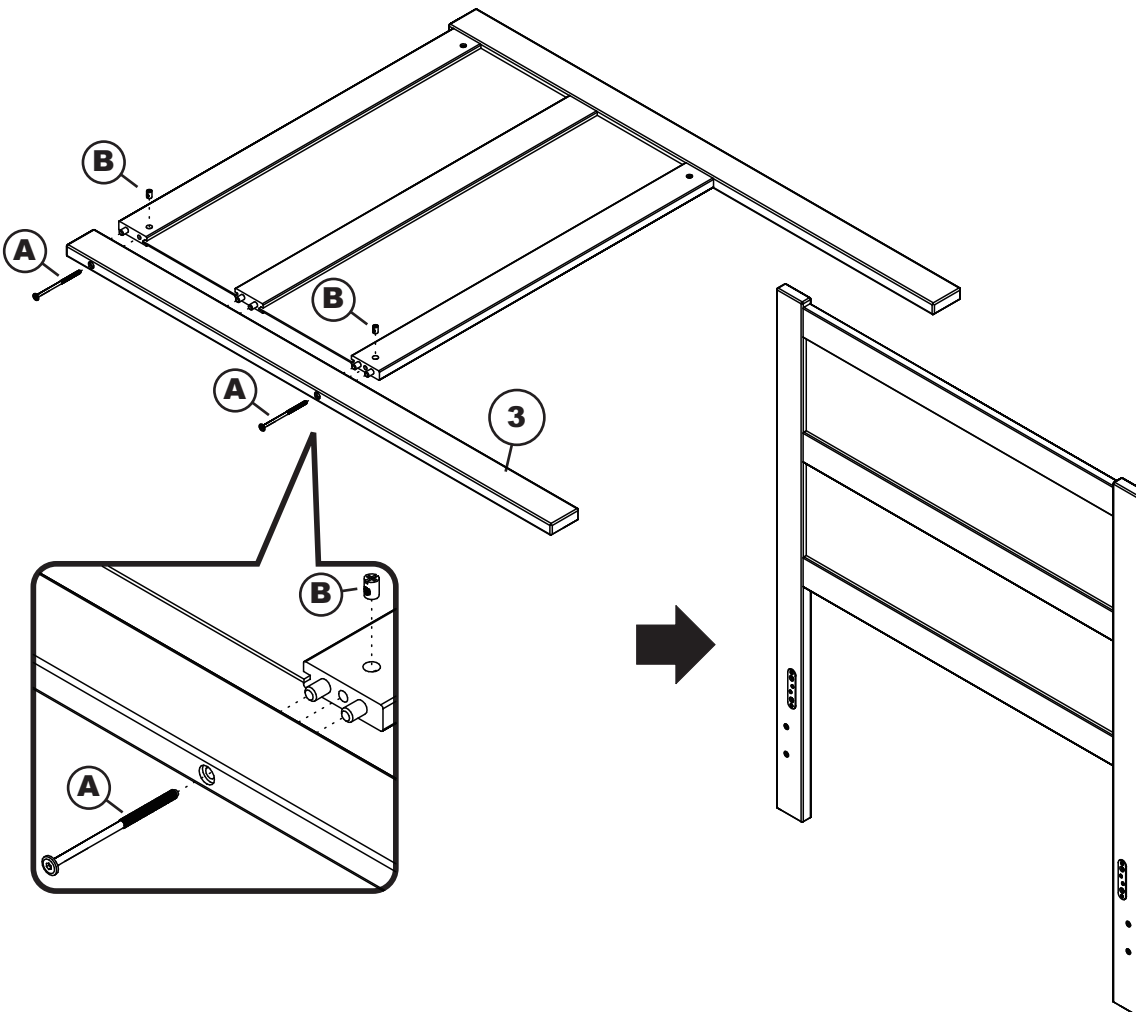

Adult assembly

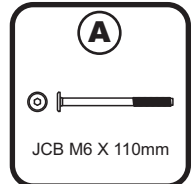

JCB M6 X 110mm

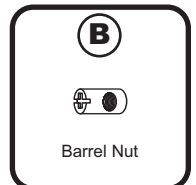

Barrel Nut

**Step 5**

Lay the left leg (8) bracket face up on smooth surface. Connect FB top rail (10) and FB bottom rail (11) as shown below, using JCB M6 X 110mm (A) and barrel nut (B). Tighten with the Allen wrench (E).

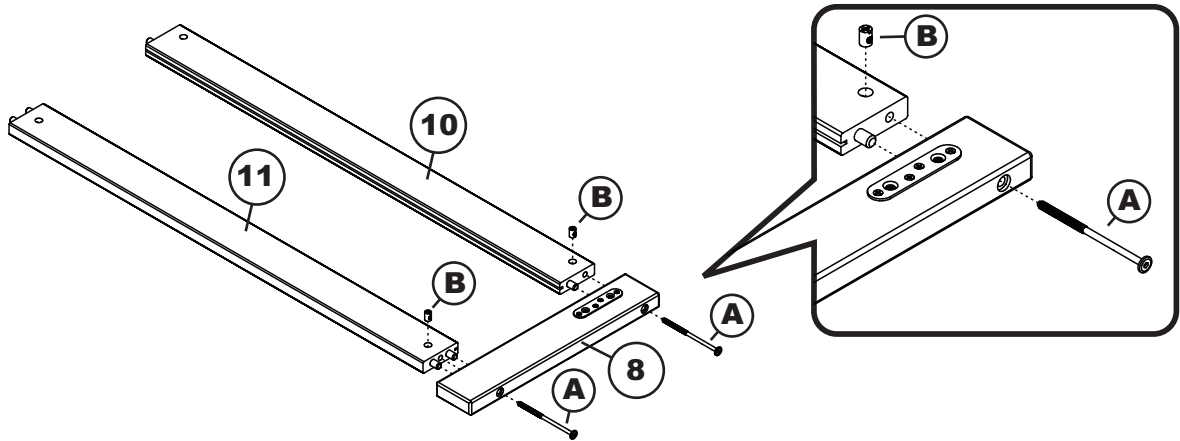
**Step 6**

Guide the footboard panel (7) in carefully so that it won't jump out of its grooves. Be sure it fits fully into the groove at the end (in the leg) before fitting the other leg.

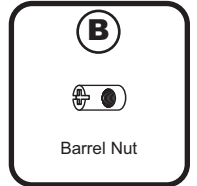
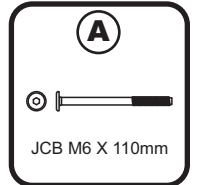
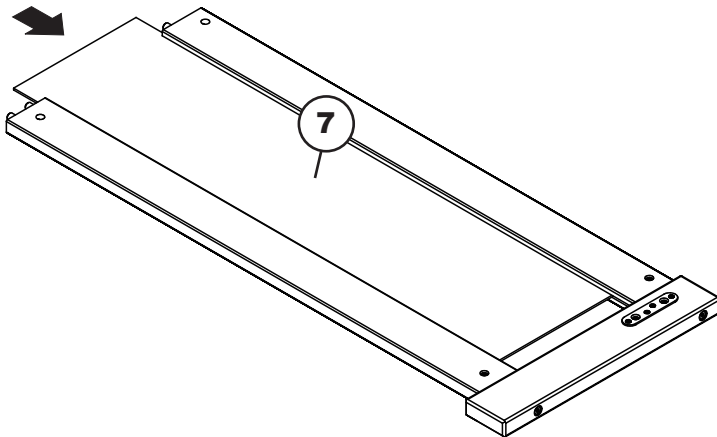
**Step 7**

Attach the right leg (9) to footboard assembly as shown below, using JCB M6 X 110mm (A) and barrel nut (B). Tighten with Allen wrench (E)

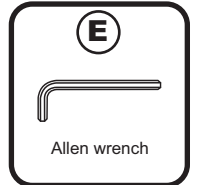
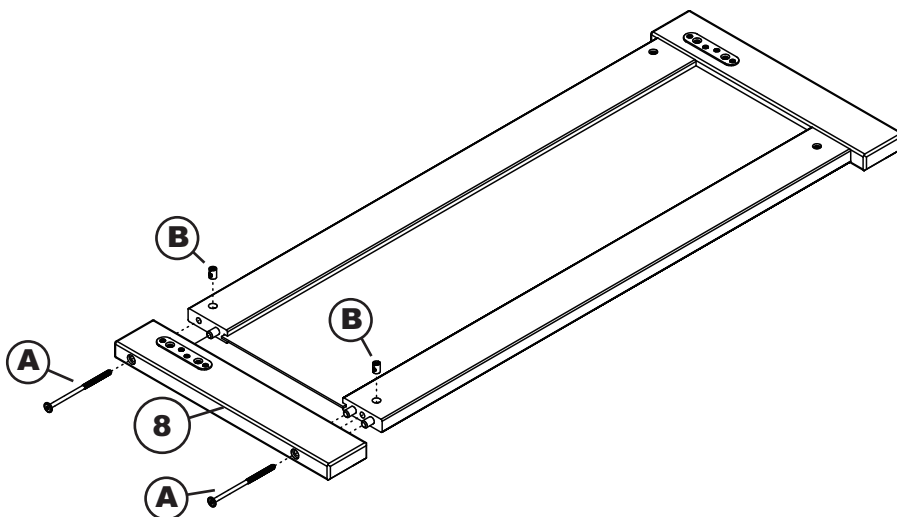

TWIN

- 01 HARDWARE
  - 02 HEADBOARD
  - 03 FOOTBOARD
- BOX 1

- 01 HARDWARE
  - 04 SIDE RAILS
  - 05 SLAT KIT
- BOX 2

**Step 1**

Attach the side rails (04) to the headboard (02) and footboard (03) using JCB M8 X 15mm (C). Tighten with Allen wrench M6 (F).

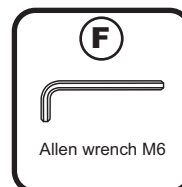
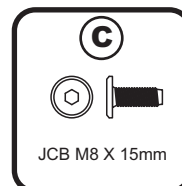
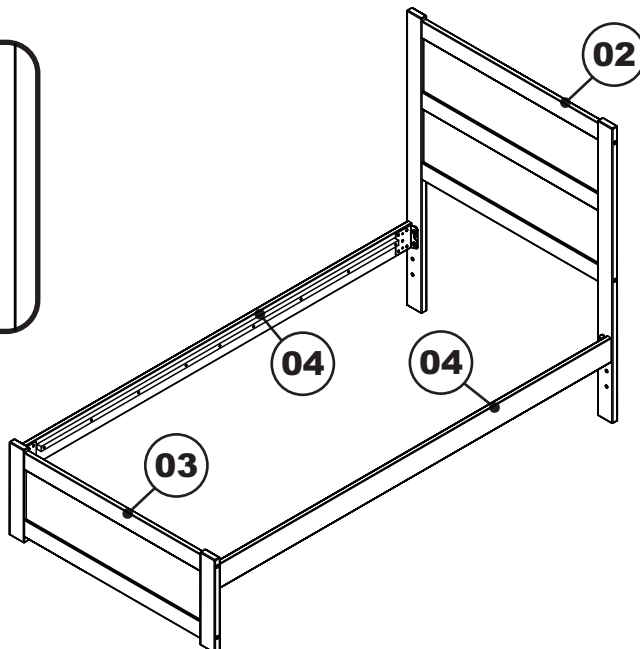
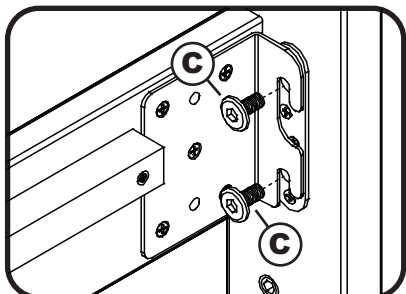

**Step 2**

Attach slat kit (05) onto the bed using wood screws. Tighten with Phillips head screw driver. (customer supplied) For assembly of slat kit, follow the assembly instructions included with bed frame.

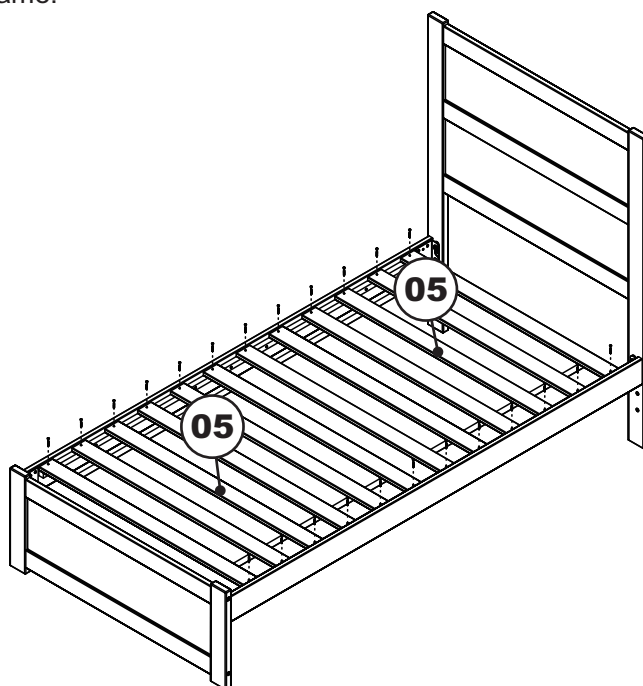

**Congratulations!**

Your bed is now ready for use.

We recommend that you periodically recheck that all screws are tight to ensure lasting safety.

## TWIN XL ASSEMBLY INSTRUCTIONS

Before assembling your bed frame, please read through these instructions carefully and familiarize yourself with the different parts.



**ATTENTION!** If you receive a damaged or defective item, please contact afifurnishings at customerservice@afifurnishings.com or 1-800-955-3726

### PARTS LIST

- ① **SIDE RAIL 2 PCS**
- ② **SLAT KIT 2 SETS**

### HARDWARE

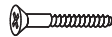
- Ⓐ  Wood screw(1 1/4") - 28 pcs  
Spare - 2 pcs

NOTE: WE INCLUDE SPARE HARDWARE IN CASE DAMAGE OCCURS DURING ASSEMBLY.

### Step 1

Attach side rails (1) to the headboard and footboard. For assembly, follow the assembly instructions included with your headboard and footboard.

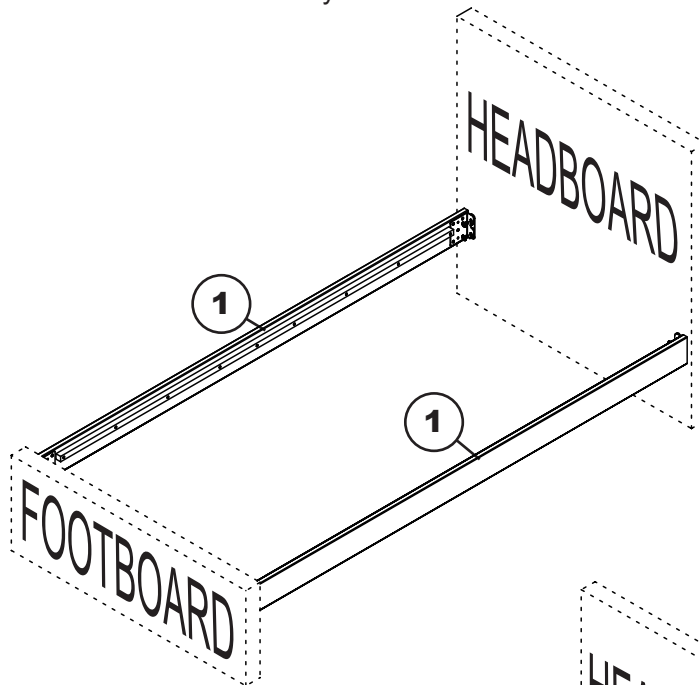

### Step 2

Attach the slat kit (2) onto the bed using wood screws 1 1/4" (A). Tighten with Phillips head screw driver. (customer supplied)

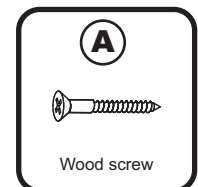
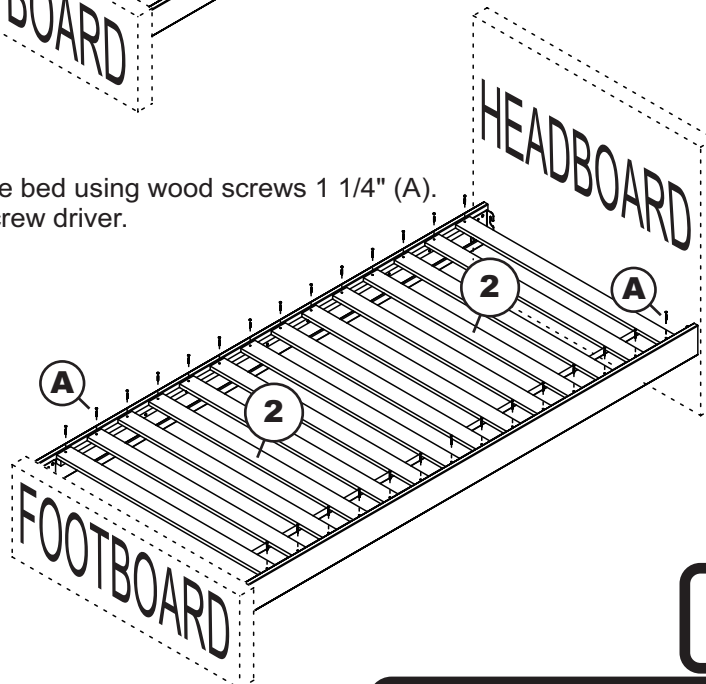
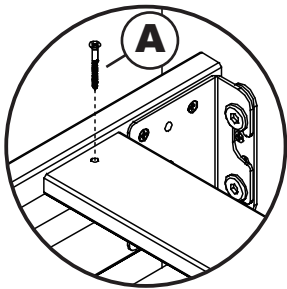

CODE	ITEM
FR-MT-ISL	G-24801X

**PO:**

## TWIN XL / QUEEN ASSEMBLY INSTRUCTIONS

Before assembling your bed drawer, please read through these instructions carefully, familiarize yourself with the different parts.

**ATTENTION!** If you receive a damaged or defective item, please contact afifurnishings at customerservice@afifurnishings.com or 1-800-955-3726

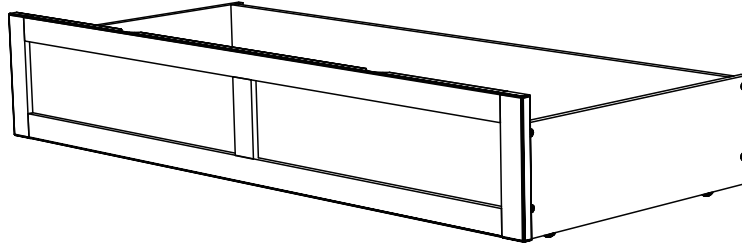
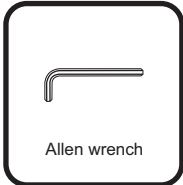

**NOTE: WE INCLUDE SPARE HARDWARE IN CASE DAMAGE OCCURS DURING ASSEMBLY.**

**HARDWARE**



**(A)** JCB M6 X 1" ( 25mm ) - 16 pcs  
Spare - 1 pc



**(B)** Wood Screw X 1 1/4" ( 32mm ) - 4 pcs  
Spare - 1 pc



**(C)** Allen wrench - 1 pc  
Spare - 1 pc

### PARTS LIST

- (01) HARDWARE 1 BOX**
- (02) DRAWER FACE 1 PC**
- (03) DRAWER SIDE 2 PCS**
- (04) DRAWER BACK 1 PC**
- (05) DRAWER BOTTOM 2 PCS**
- (06) DRAWER MIDDLE 1 PC**
- (07) DRAWER CENTER SUPPORT 1 PC**

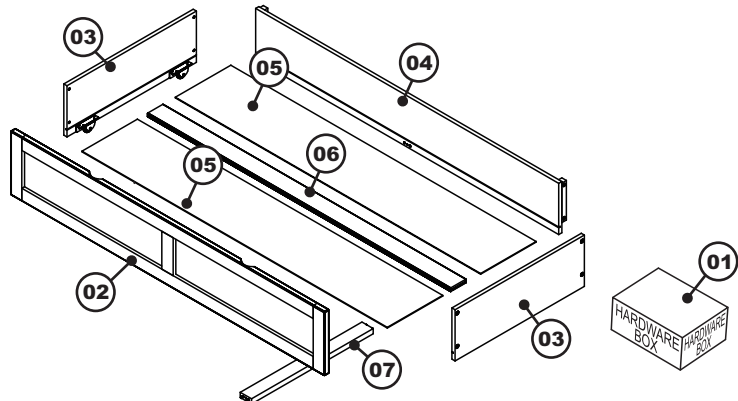

**Step 1** Lay the drawer face (02) on smooth, flat surface so the drawer bottom (05) groove is facing upwards. Attach the drawer sides (03) to drawer face (02) using JCB M6 X 1" (A). Align groove inside drawer side with groove in drawer face. Tighten with Allen wrench (C).

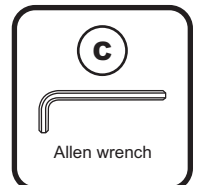
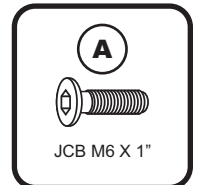
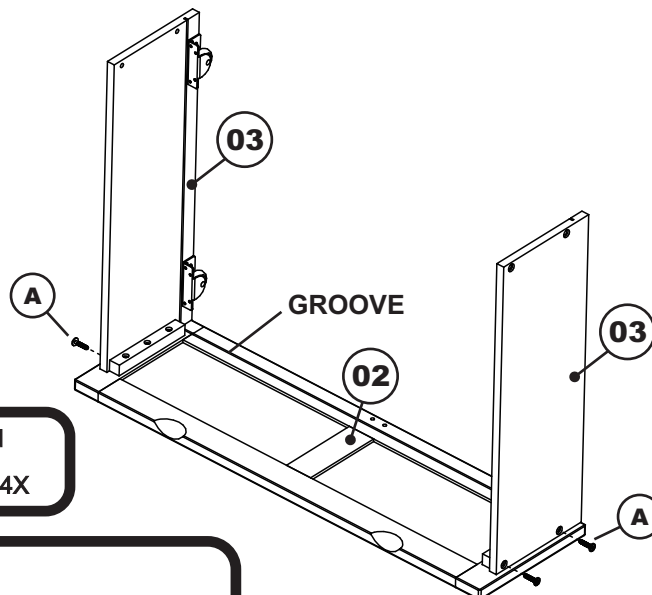

CODE	ITEM
ST-DR2-ISL	G-32804X

**PO :**

## TWIN XL / QUEEN

### Step 2

Guide the drawer bottoms (05) and drawer middle (06) in carefully so that they align inside grooves. Be sure it fits fully into the face and side groove before attaching the drawer back (04). Attach drawer center support (07) to bottom of drawer face using wood screw 1 1/4" (B). Tighten with Phillips head screw driver. (Customer supplied)

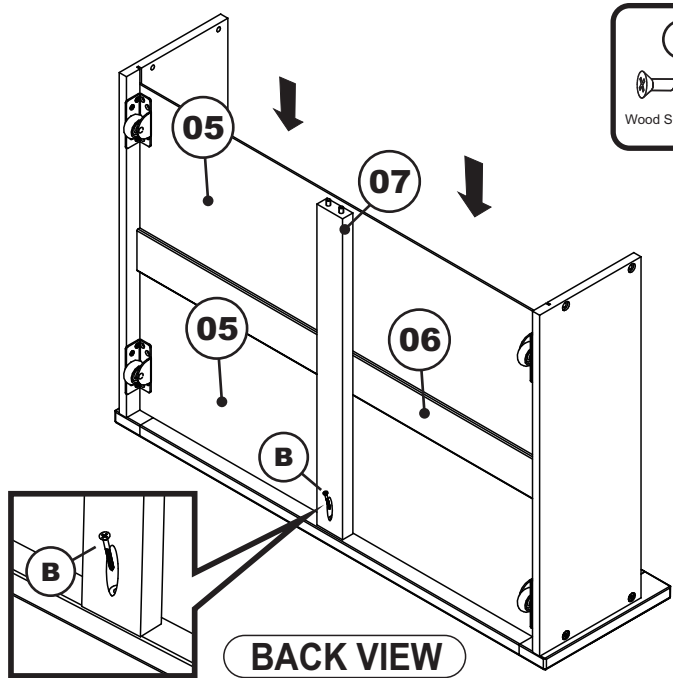
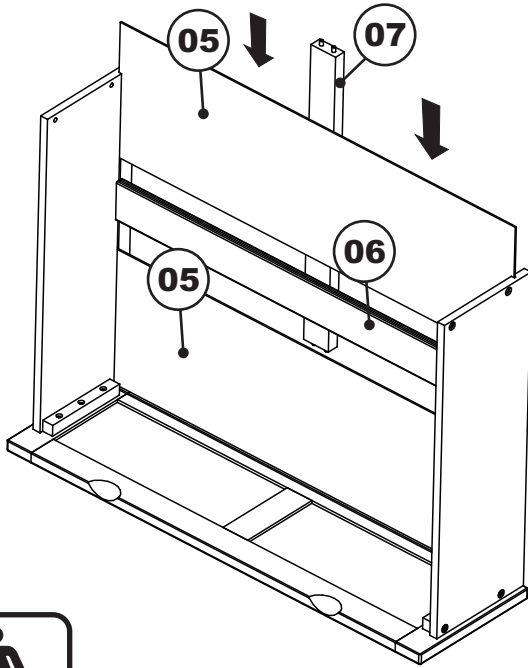

### Step 3

Attach drawer back (04) to bed drawer assembly as shown. Use JCB M6 X 1" (A). Tighten with Allen wrench (C). Use wood screws 1 1/4" (B) to finish attaching drawer center support (07) to drawer back (04). Tighten with Phillips head screw driver. (customer supplied)

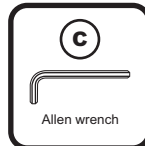
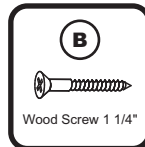
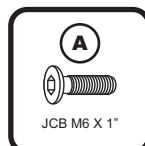
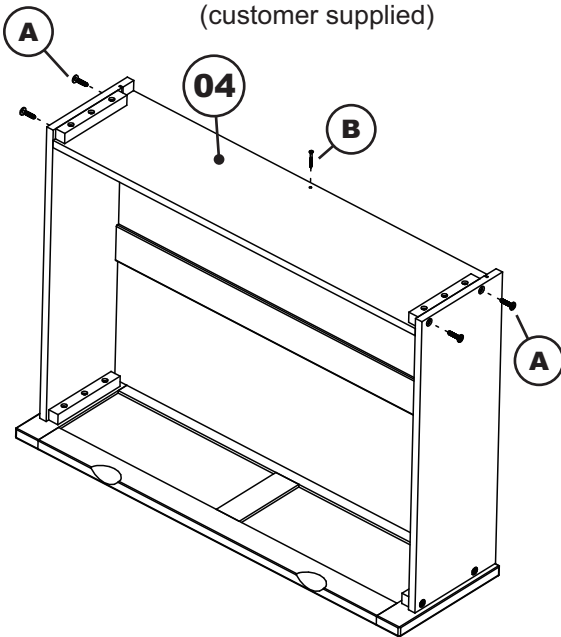

## Congratulations!

Your bed drawer is now ready for use.  
We recommend that you periodically recheck that all screws are tight to ensure lasting safety.

