

ASSEMBLY INSTRUCTIONS

Before assembling your headboard, please read through these instructions carefully and familiarize yourself with the different parts.

ATTENTION! If you receive a damaged or defective item, please contact afifurnishings at customerservice@afifurnishings.com or 1-800-955-3726



PARTS LIST

- ① HEADBOARD PANEL BOARDS 4 PCS
- ② LEFT LEG 1 PC
- ③ RIGHT LEG 1 PC
- ④ HEADBOARD SUPPORT 1 PC

Instructions apply for bed sizes
FULL > QUEEN

HARDWARE

- ① JCB M6 X 35mm - 16 pcs
Spare - 1 pc
- ② JCB M8 X 15mm (5/8") - 4 pcs
Assembly headboard to open bed frame
- ③ Wood screw 1 1/4" - 4 pcs
Spare - 1 pc
- ④ Allen wrench - 1 pc
Spare - 1 pc

- HARDWARE FOR METAL BED FRAME
- ① JCB M6 X 25mm (1") - 4 pcs
Spare - 1 pc
 - ② Flat washer - 4 pcs
Spare - 1 pc
 - ③ Split washer - 4 pcs
Spare - 1 pc

NOTE: WE INCLUDE SPARE HARDWARE IN CASE DAMAGE OCCURS DURING ASSEMBLY.

Step 1

Attach the legs (2) and (3) to headboard panel boards (1) using JCB M6 X 35mm (A). Tighten with the Allen wrench (G).

Step 2

Attach headboard support (4) to headboard panel boards using wood screw 1 1/4" (C) Tighten with the Phillips head screw driver. (Customer supplied)

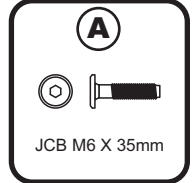
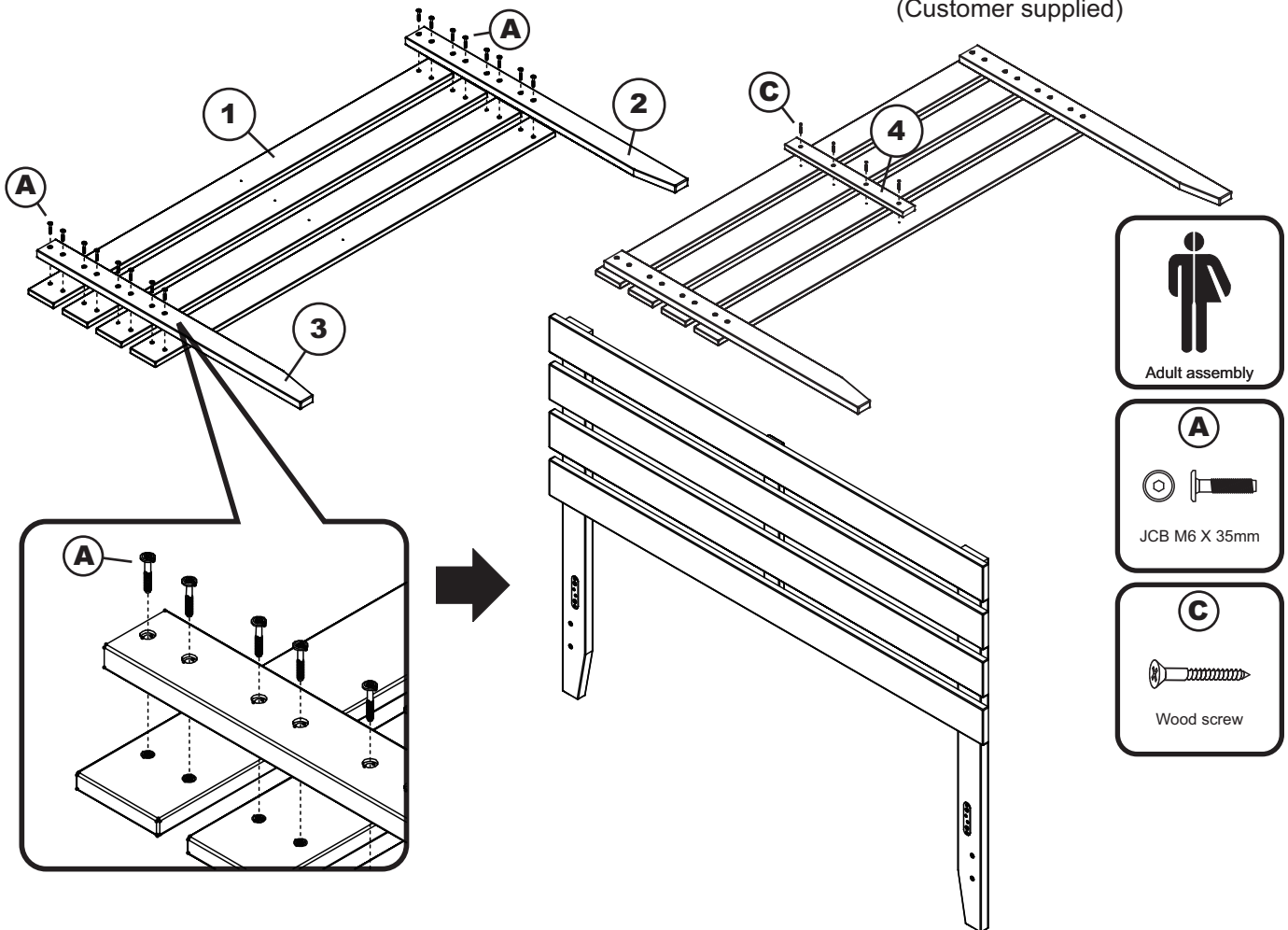

FOR BED FRAME ASSEMBLY follow assembly instructions included with your bed frame. If you purchased a wood headboard to attach to metal bed frame, please refer to page 2.

PO:

| CODE | ITEM | ITEM |
|------------|----------|----------|
| HB-ISL-OXD | G-11833X | G-11834X |

QUEEN

ASSEMBLY INSTRUCTIONS

Before assembling your bed frame, please read through these instructions carefully and familiarize yourself with the different parts.



ATTENTION! If you receive a damaged or defective item, please contact afifurnishings at customerservice@afifurnishings.com or 1-800-955-3726

PARTS LIST

| | | |
|---|-----------------------|---------------|
| ① | FOOT RAIL | 1 PC |
| ② | LEFT LEG | 1 PC |
| ③ | RIGHT LEG | 1 PC |
| ④ | SIDE RAILS | 2 PCS |
| ⑤ | SLAT KIT | 2 SETS |
| ⑥ | SLAT SUPPORT 1 | 1 PC |
| ⑦ | SLAT SUPPORT 2 | 1 PC |
| ⑧ | SUPPORT LEGS | 3 PCS |

HARDWARE

| | | | | |
|---|---------------------------------|---------------|---|-------------------------------|
| ① | JCB M6 X 110mm (4 3/8") - 2 pcs | Spare - 1 pc | ⑤ | JCB M6 X 30mm (1 1/4") - 6pcs |
| ② | Barrel nut - 2 pcs | | ⑥ | Cap nut - 6pcs |
| ③ | JCB M8 X 15mm (5/8") - 4 pcs | | ⑦ | Allen wrench M6 - 1pc |
| ④ | Wood screw (1 1/4") - 29 pcs | Spare - 2 pcs | ⑧ | Allen wrench M4 - 1pc |
| | | | ⑨ | Split washer - 3pcs |
| | | | ⑩ | Spare - 1pc |
| | | | ⑪ | Flat washer - 3pcs |
| | | | ⑫ | Spare - 1pc |

NOTE: WE INCLUDE SPARE HARDWARE IN CASE DAMAGE OCCURS DURING ASSEMBLY.

Step 1

Attach the legs (2) and (3) to foot rail (1), using JCB M6 X 110mm (A) and barrel nut (B).
Tighten with the Allen wrench M4 (I).

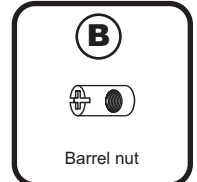
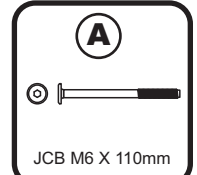
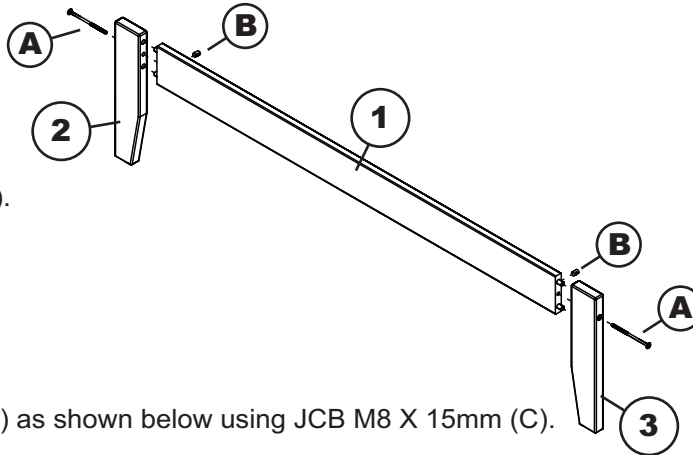

Step 2

Attach side rails (4) to the foot rail (1) as shown below using JCB M8 X 15mm (C).
Tighten with Allen wrench M6 (H).

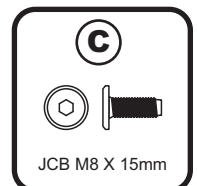
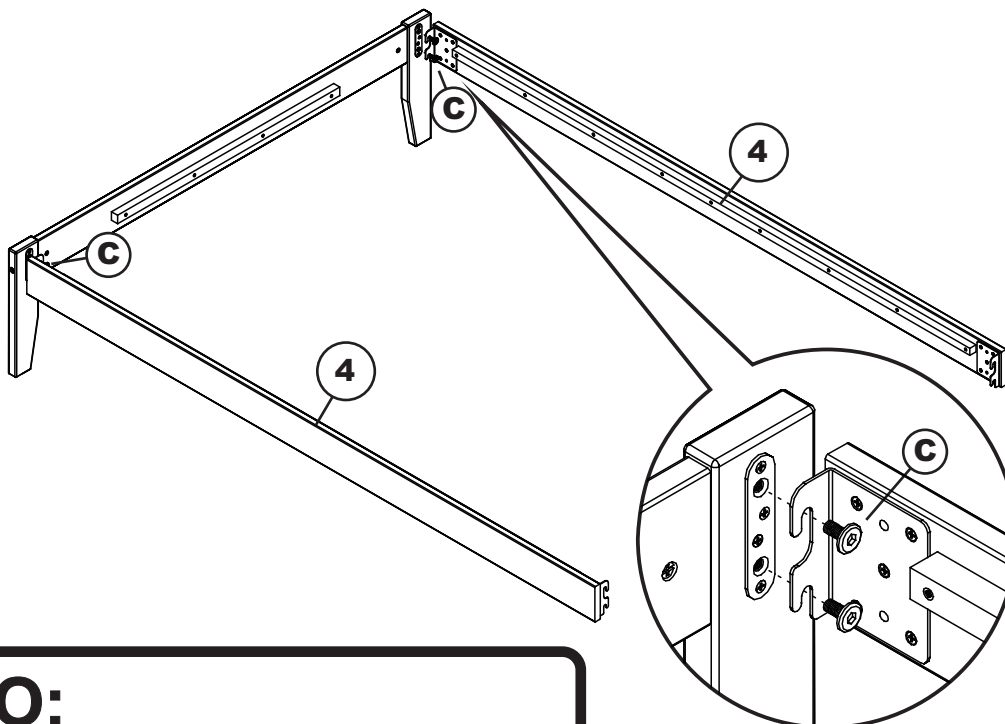

PO:

QUEEN



Step 3

Attach open bed frame to the headboard as shown below using 4 JCB M8 X 15mm bolts that are supplied with your headboard. Tighten with the Allen wrench M6 (H).

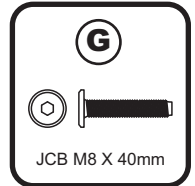
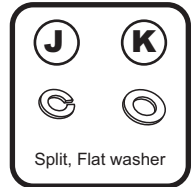
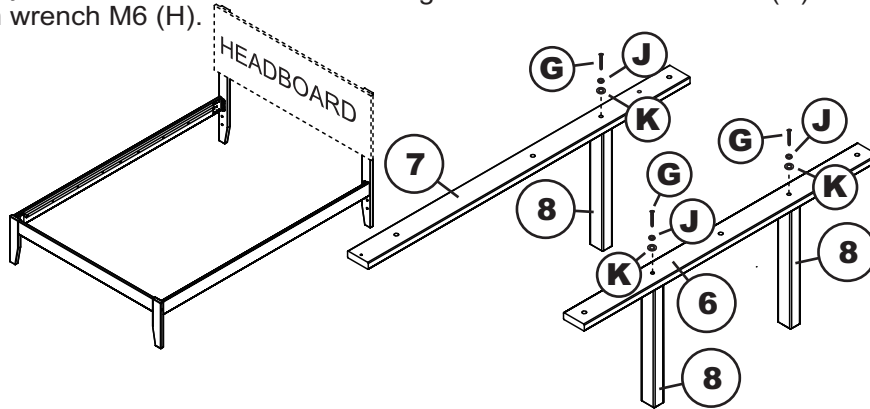
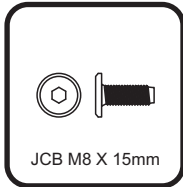

Step 5

Attach slat support 1(6) and slat support 2 (7) to the slat kit (5) as shown below using JCB M6 X 30mm (E) and cap nut (F). Tighten with Allen wrench M4 (I).

2 legs at headboard section.

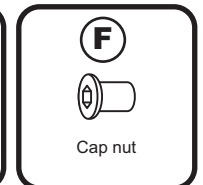
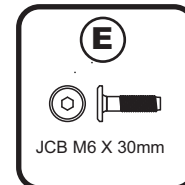
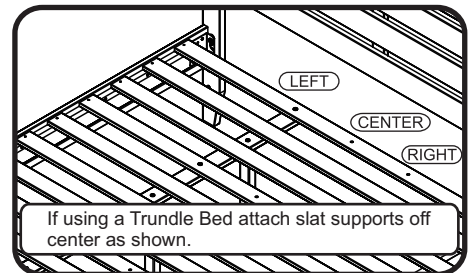
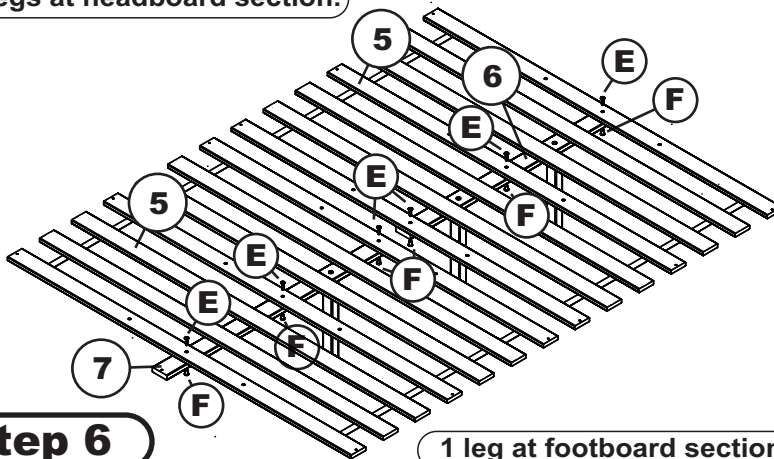

Step 6

Attach 2 slat kits (5) to the open bed frame as shown below using wood screws 1 1/4" (D). Tighten with Phillips head screw driver. (customer supplied)

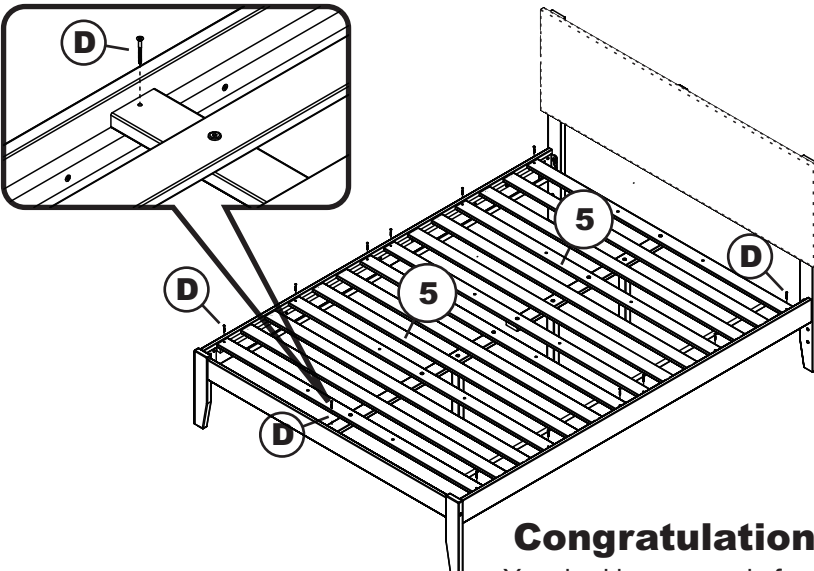

Congratulations!

Your bed is now ready for use.

We recommend that you periodically recheck that all screws are tight to ensure lasting safety.