

Size of Mattress and Foundation

The length and width of the upper and lower bunk mattress and foundation are as follows :

<u>Size</u>	<u>Length</u>	<u>Width</u>	<u>Thickness</u>
Twin	74" - 75"	37 ½" - 38 ½"	9 ½" max
Full	74" - 75"	52" - 53"	9 ½" max

You must use only this size mattress.

Ensure thickness of upper and lower mattress and foundation combined does not exceed 9 ½" and that the mattress is at least 5" below upper edge of guardrails.

This Bunk Bed uses a slat kit for mattress foundation.

Replacement Parts

Replacement parts, including additional guardrails, may be obtained from any affurnishings dealer



SAFETY WARNINGS



- (1) Follow the information on the warnings appearing on the upper bunk end structure and on the carton. Do not remove warning label from bed.
- (2) Always use the recommended size mattresses or mattress support, or both, to help prevent the likelihood of entrapment or falls.
- (3) Surface of mattress must be at least 5 in. (127mm) below the upper edge of guardrails.
- (4) Do not allow children under 6 years of age to use the upper bunk.
- (5) Periodically check and ensure that the guardrail, ladder, and other component are in their proper position, free from damage, and that all connectors are tight.
- (6) Do not allow horseplay on or under the bed and prohibit jumping on the bed.
- (7) Always use ladder for entering or leaving upper bunk.
- (8) Do not use substitute parts. Contact the manufacturer or dealer for replacement parts.
- (9) Use of a night light may provide added safety precaution for a child using the upper bunk.
- (10) Always use guardrails on both long sides of the upper bunk. If the bunk bed will be placed next to the wall, the guardrail that runs the full length of the bed should be placed against the wall to prevent entrapment between the bed and the wall.
- (11) The use of water or sleep flotation mattresses is prohibited.
- (12) **STRANGULATION HAZARD** : Never attach or hang items to any part of the bunk bed that are not designed for use with the bed; for example, but not limited to, hooks, belts and jump ropes.
- (13) Keep these instructions for future reference.

ASSEMBLY INSTRUCTIONS

(TWIN - TWIN & TWIN - FULL)



Before assembling your staircase bookshelf bunk bed, please read through these instructions carefully. Familiarize yourself with the different parts.

Please note that you will require a phillips screwdriver and an allen wrench.

ATTENTION! If you receive a damaged or defective item, please contact afifurnishings at customerservice@afifurnishings.com or 1-800-955-3726

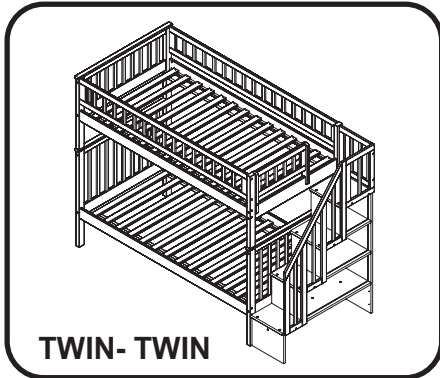

TWIN- TWIN

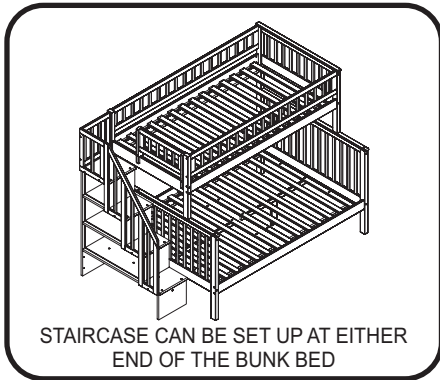
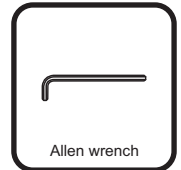
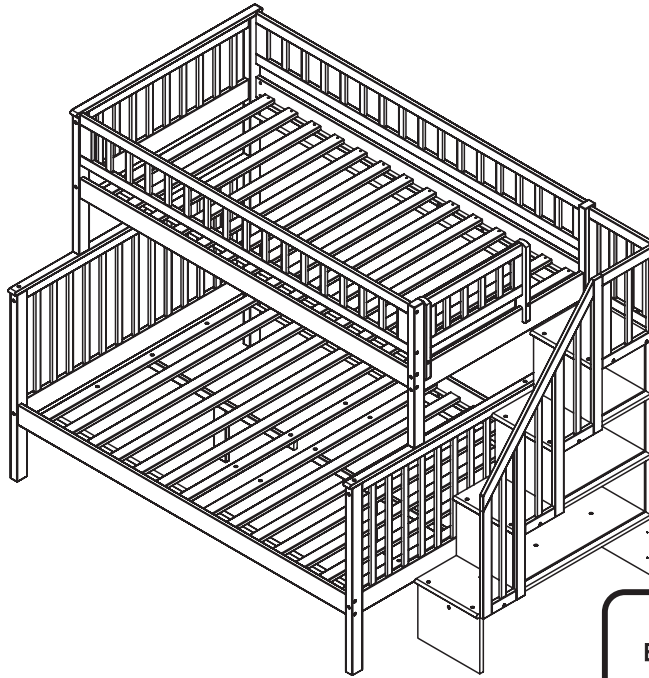

TWIN OVER FULL SHOWN

STAIRCASE CAN BE SET UP AT EITHER END OF THE BUNK BED

CODE	ITEM
BK-SCPL-WDL	B-5621X
BK-SCPL-WDL	B-5651X
BK-SCGR-WDL	B-5611X
BK-SCBS-WDL	B-5411X
BK-SCBS-WDL	B-5221X

PO:

HARDWARE

NOTE: WE INCLUDE SPARE HARDWARE IN CASE DAMAGE OCCURS DURING ASSEMBLY.

- A** JCB M6 X 3 1/8" - 16 pcs
Spare - 2 pcs
- B** Barrel nut - 16 pcs
Spare - 2 pcs
- C** Wooden dowel - 26 pcs
Spare - 2 pcs
- D** Allen screw 2 3/8" - 8 pcs
Spare - 2 pcs
- E** Allen screw 1 5/8" - 36 pcs
Spare - 2 pcs
- F** Allen screw 2 3/4" - 4 pcs
Spare - 2 pcs
- G** Metal pins - 4 pcs
- H** Wood screw 1 1/4" - 2 pcs
Spare - 1 pc
- I** Wood screw 5/8" - 13 pcs
Spare - 2 pcs
- J** L bracket - 4 pcs
- K** Large L bracket - 1 pc
- L** Wood buttons - 4 pcs
- M** Allen wrench - 2 pcs
Spare - 1 pc
- N** Surface Mount Charger - 1 set
Screws 1/2" - 2 pcs
Spare - 1 pc

(TWIN - FULL)

PARTS LIST

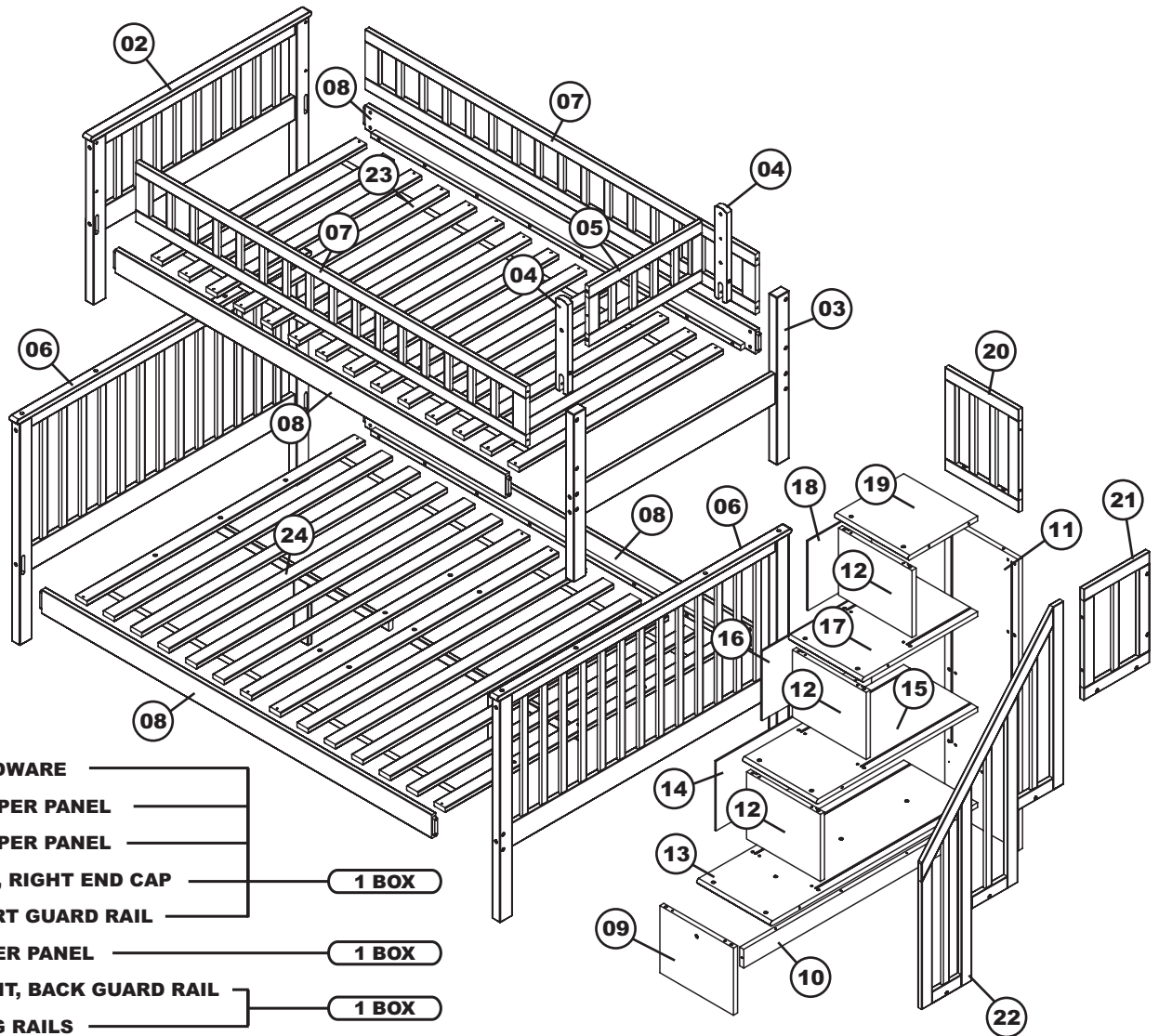

- 01 HARDWARE
- 02 A UPPER PANEL
- 03 B UPPER PANEL
- 04 LEFT, RIGHT END CAP — 1 BOX
- 05 SHORT GUARD RAIL
- 06 LOWER PANEL — 1 BOX
- 07 FRONT, BACK GUARD RAIL — 1 BOX
- 08 LONG RAILS
- 09 FLOOR STORAGE SIDE PANEL
- 10 BOTTOM CROSS BRACE
- 11 LONG SIDE PANEL
- 12 BOOKSHELF SIDE PANEL
- 13 FLOOR STORAGE TOP PANEL
- 14 BOOKSHELF BACK PANEL 1
- 15 BOOKSHELF TOP PANEL 1
- 16 BOOKSHELF BACK PANEL 2 — 1 BOX
- 17 BOOKSHELF TOP PANEL 2
- 18 BOOKSHELF BACK PANEL 3
- 19 BOOKSHELF TOP PANEL 3
- 20 BACK SHORT GUARD RAIL
- 21 SIDE SHORT GUARD RAIL
- 22 HAND GUARD RAIL
- 23 TWIN SLAT KIT — 1 BOX
- 24 FULL LOWER BUNK SLAT KIT — 1 BOX

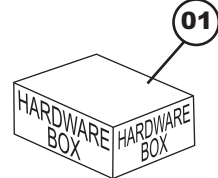

(TWIN - FULL)

STEP 1

Attach the long rails (08) to the upper panels (02)(03), using JCB M6 X 3 1/8" (A) and barrel nut (B). Tighten with the allen wrench (M).

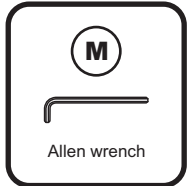
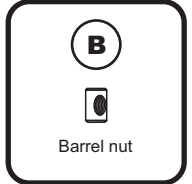
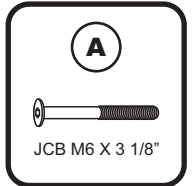
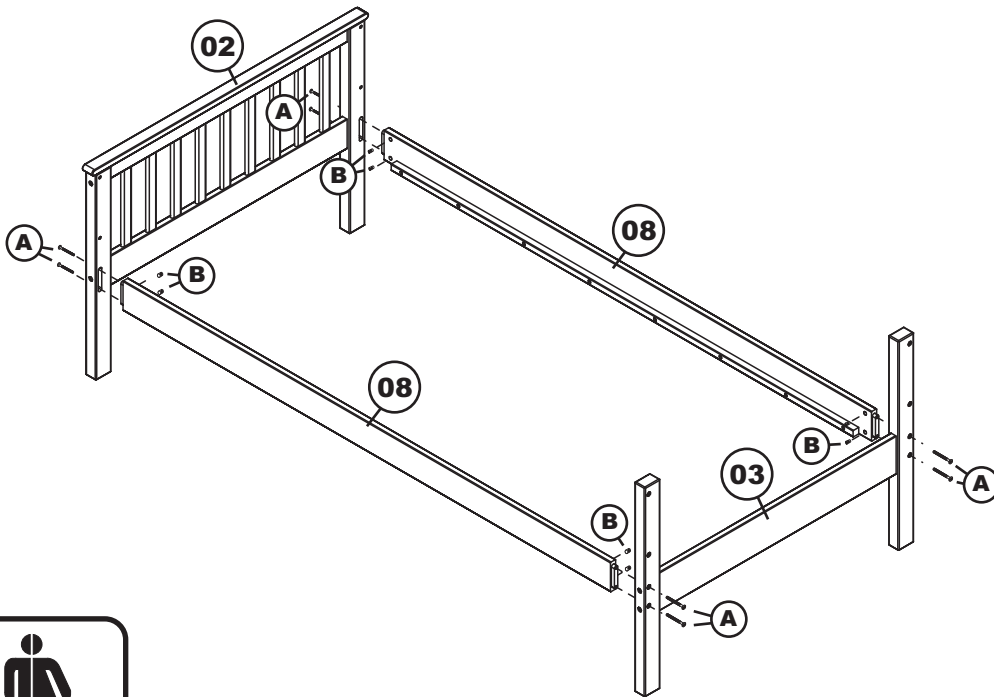

STEP 2

Lay the twin slat kit (23) onto the bed. Fix in place using wood screws provided in the slat kit box. FOR SLAT KIT ASSEMBLY follow assembly instructions included with slat kit.

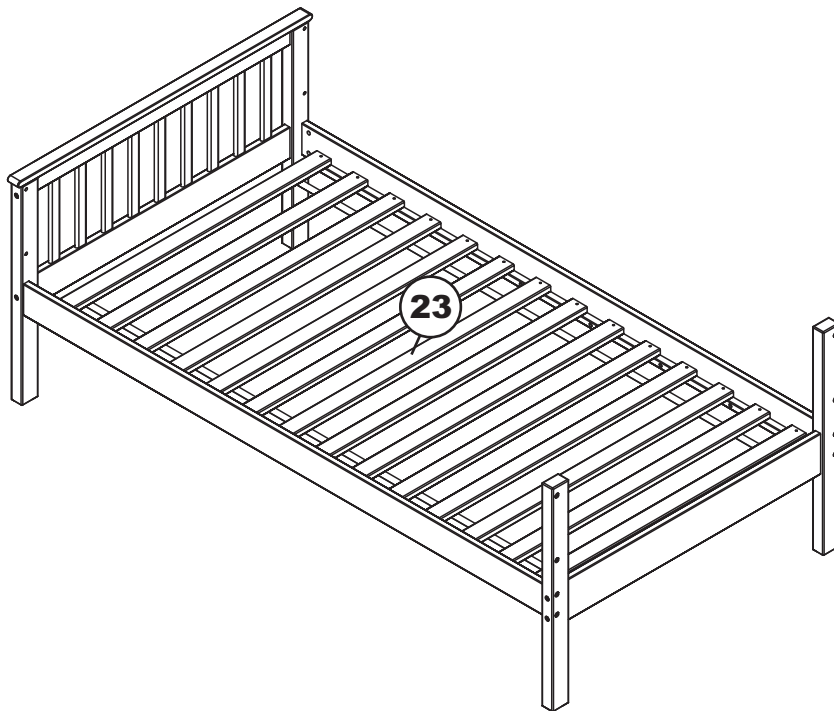

(TWIN - FULL)

STEP 3

Attach the front, back guard rails (07) to the upper panel assemblies using allen screw (D). Tighten with the allen wrench (M).

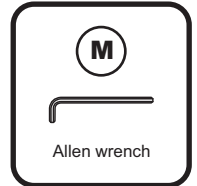
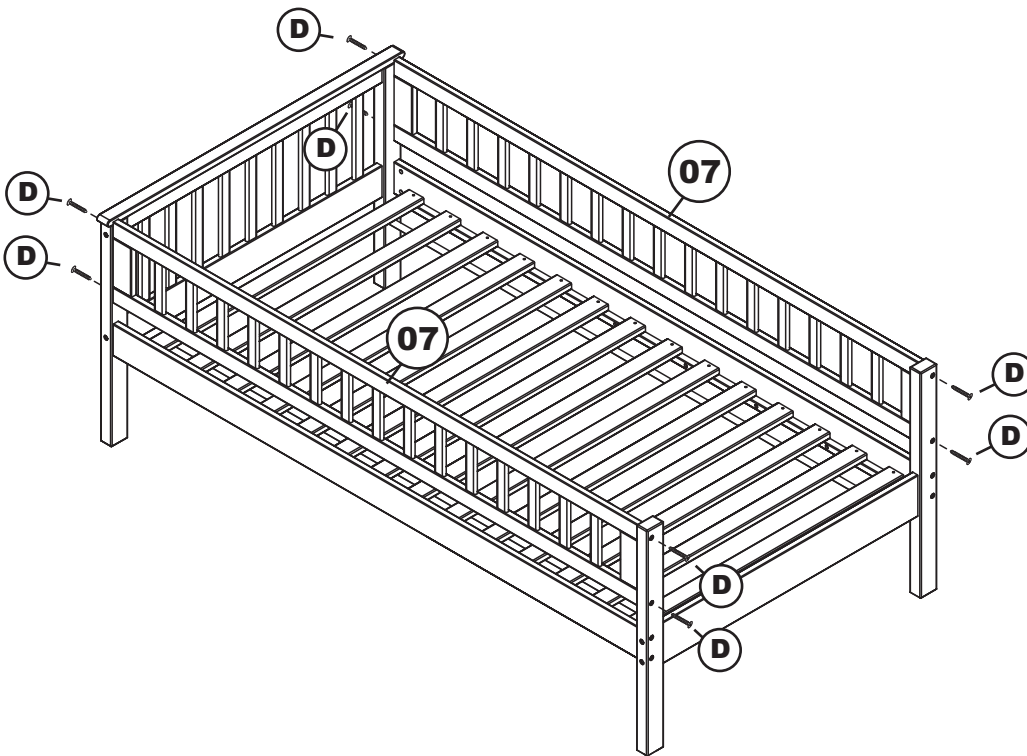

STEP 4

Insert wooden dowel (C) to the locator holes will receive C as shown below. Attach the short guard rail (05) to the left, right end caps (04), using allen screw (E), Tighten with the allen wrench (M).

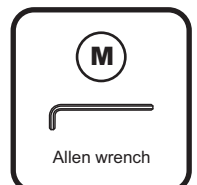
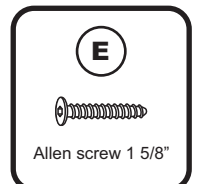
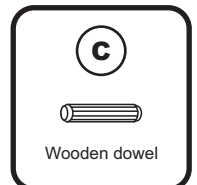
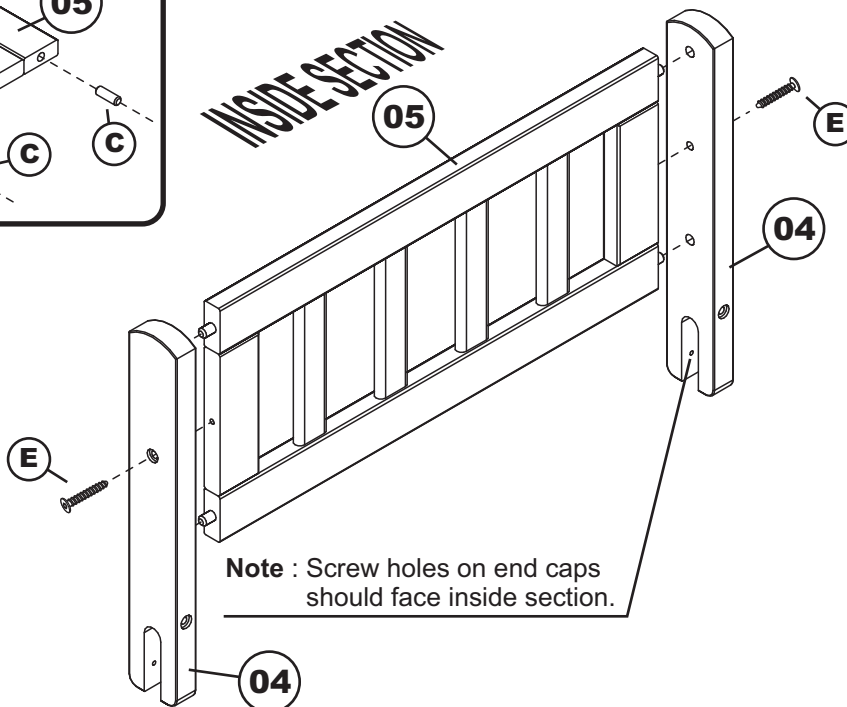
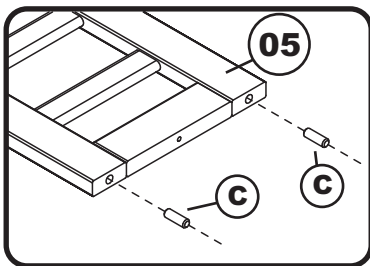

(TWIN - FULL)

STEP 5

Attach the short guard rail assemblies to the upper panel assemblies as shown below, using wood screw (H), tighten with the Phillips screwdriver. (customer supplied)

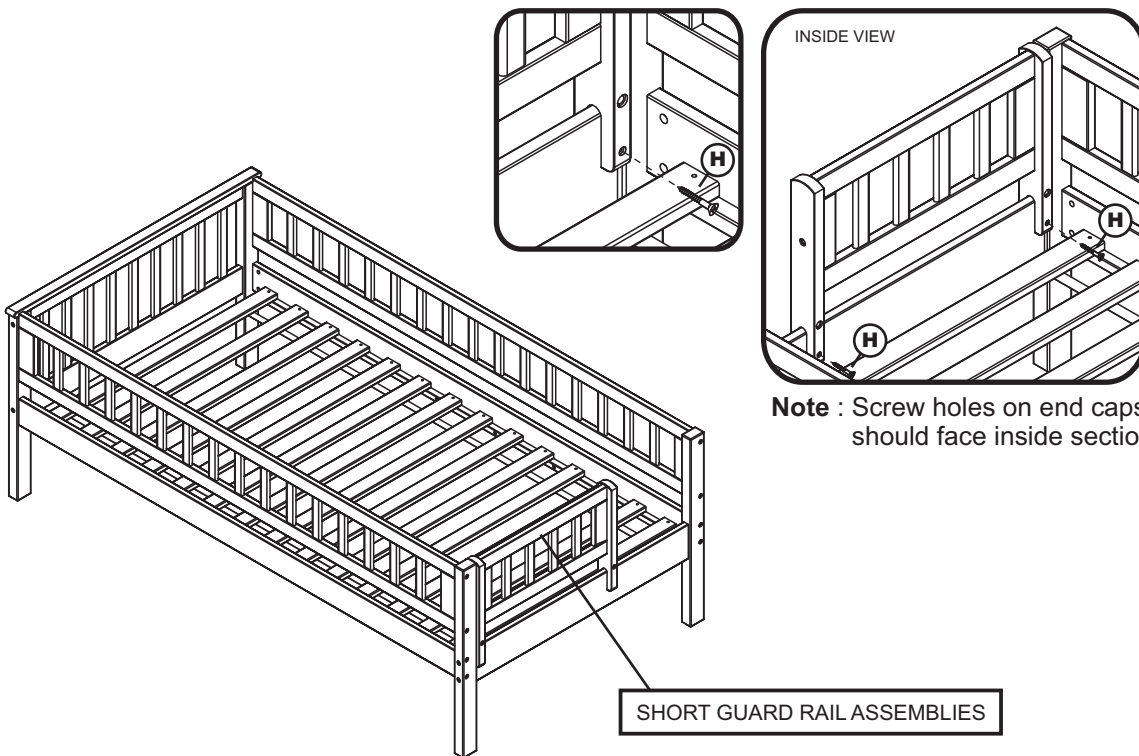

STEP 6

Attach the long rails (08) to the lower panel (06) using JCB M6 X 3 1/2" (A), and barrel nut (B). Tighten with the allen wrench (M).

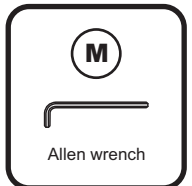
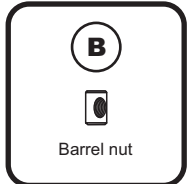
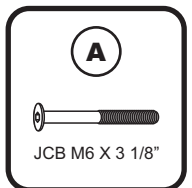
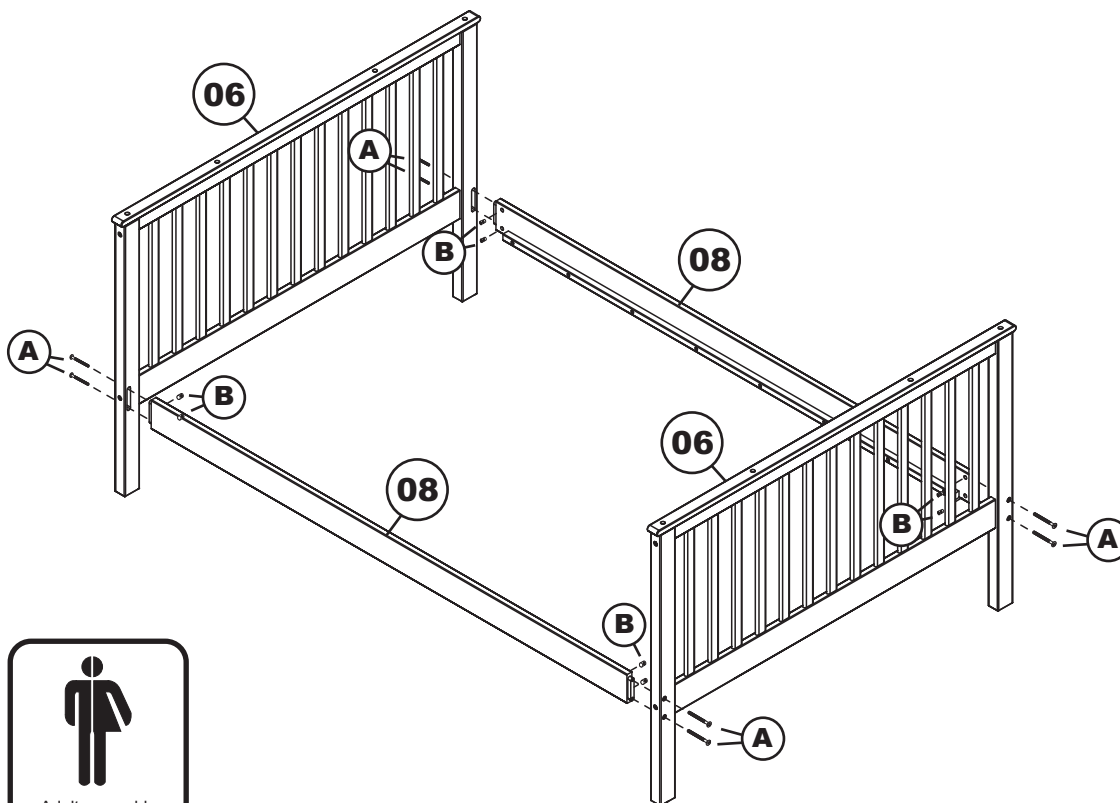

(TWIN - FULL)

STEP 7

Lay the full slat kit (24) onto the bed. Fix in place using wood screws provided in the slat kit box. FOR SLAT KIT ASSEMBLY follow assembly instructions included with slat kit.

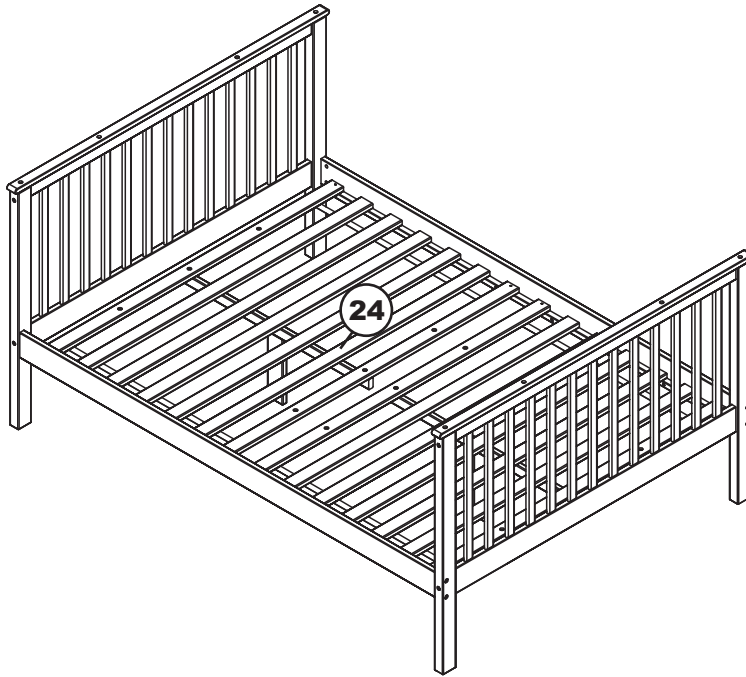

STEP 8

Insert metal pins (G) into the holes on top of the lower panels. Lift the upper panels onto the lower panels as shown, and fit the metal pins into the holes in the bottom of the upper panel legs.

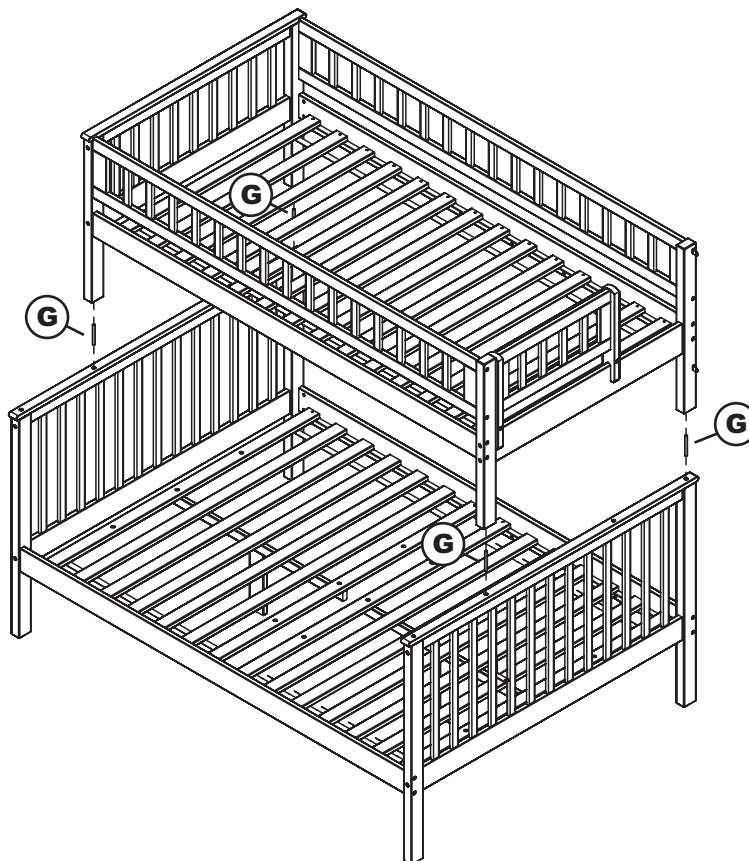
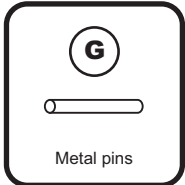

CAUTION
This step requires two strong people.

(TWIN - FULL)

STEP 9

Insert wooden dowel (C) to the locator holes will receive C as shown below.

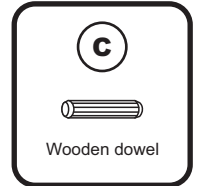
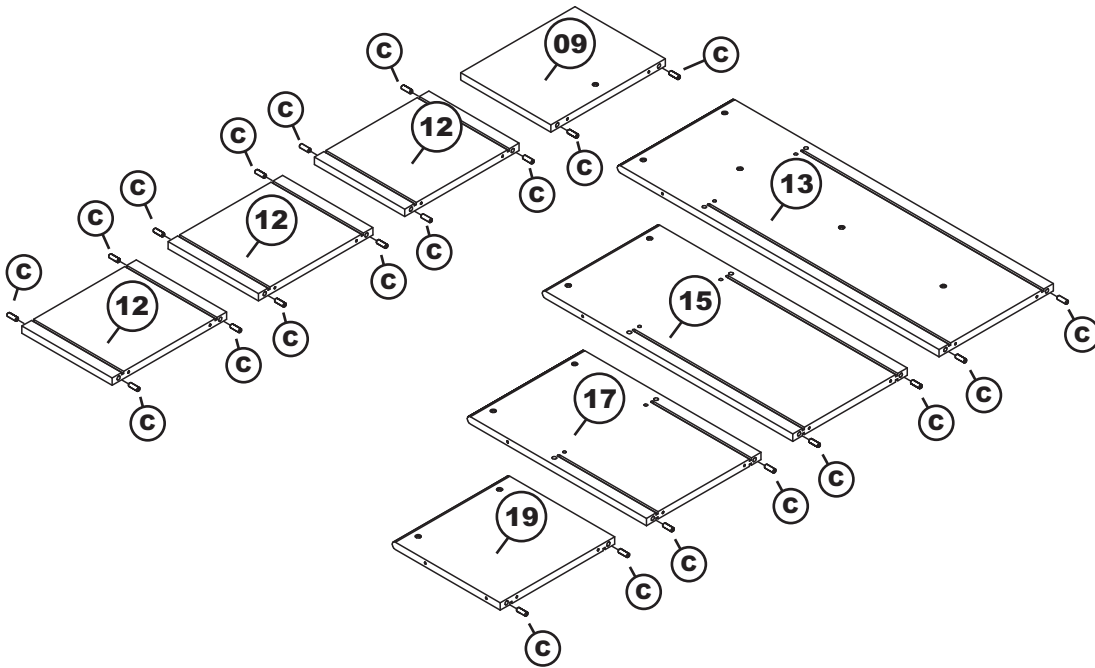

STEP 10

Attach bottom cross brace (10) to the floor storage side panel (09) as shown below. Using allen screw (E). Tighten with allen wrench (M), but don't fully tighten this yet.

Attach floor storage top panel (13) to the floor storage side panel assemblies. Using allen screw (E). Tighten with allen wrench (M).

Attach long side panel (11) to the floor storage side panel assemblies. Using allen screw (E). Tighten with allen wrench (M). After this, tighten allen screw on the floor storage side panel.

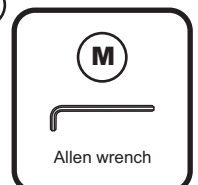
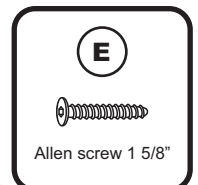
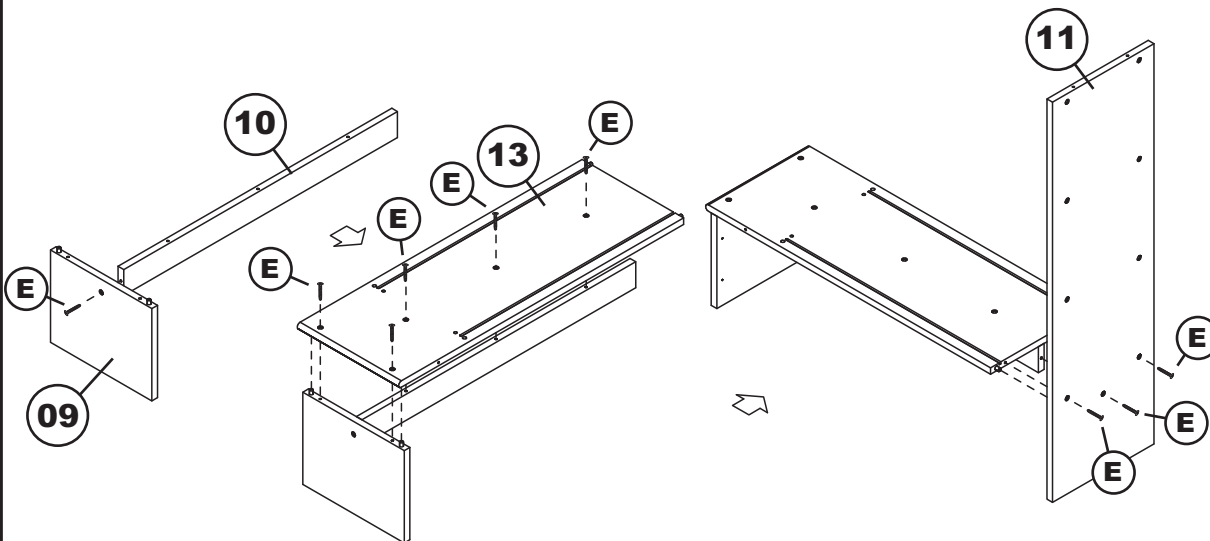

(TWIN - FULL)

STEP 11

Attach bookshelf side panel (12) to the floor storage side panel assemblies as shown below. Using allen screw (E). But don't fully tighten these yet. Leave them a bit loose to make fitting the back panel easier. Guide bookshelf back panel 1 (14) in carefully so that it won't jump out of its grooves. Be sure it fits fully into the groove at the bottom (in floor storage top panel).

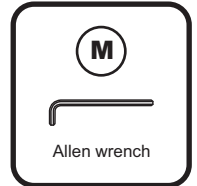
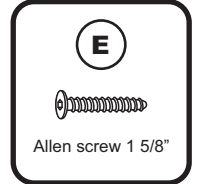
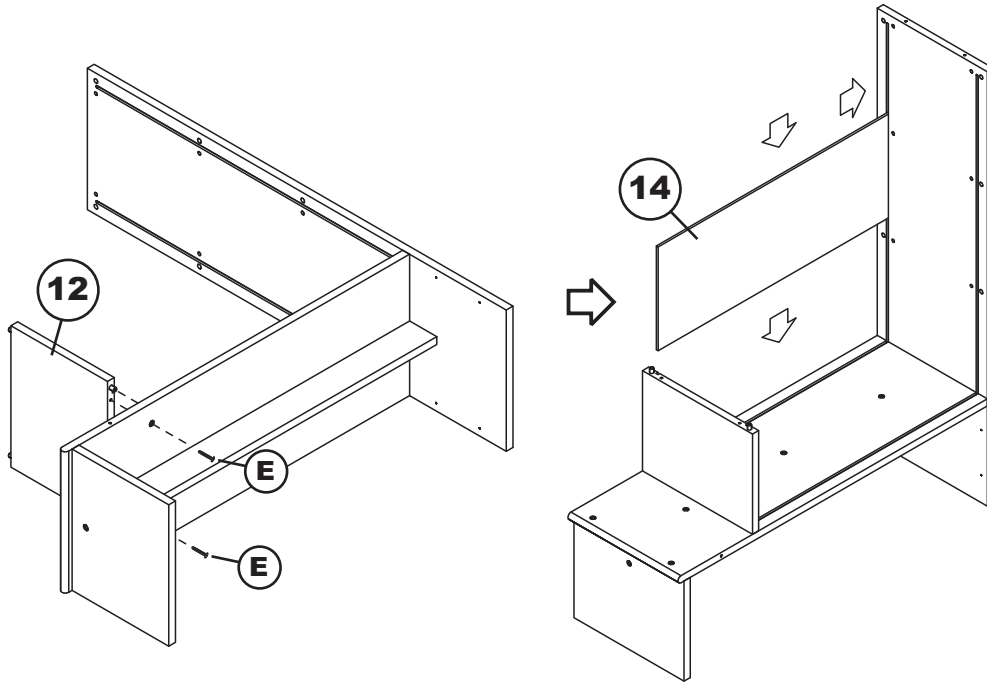

STEP 12

Attach bookshelf top panel 1(15) to the bookshelf side panel (12) using allen screw (E). Tighten with allen wrench (M). Attach bookshelf top panel assemblies to the floor storage assemblies, using allen screw (E). Tighten with allen wrench (M). Guide bookshelf back panel 2 (17) same as step 11.

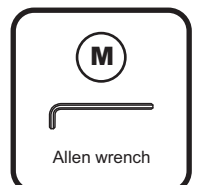
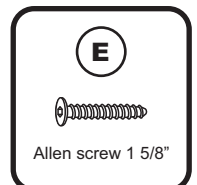
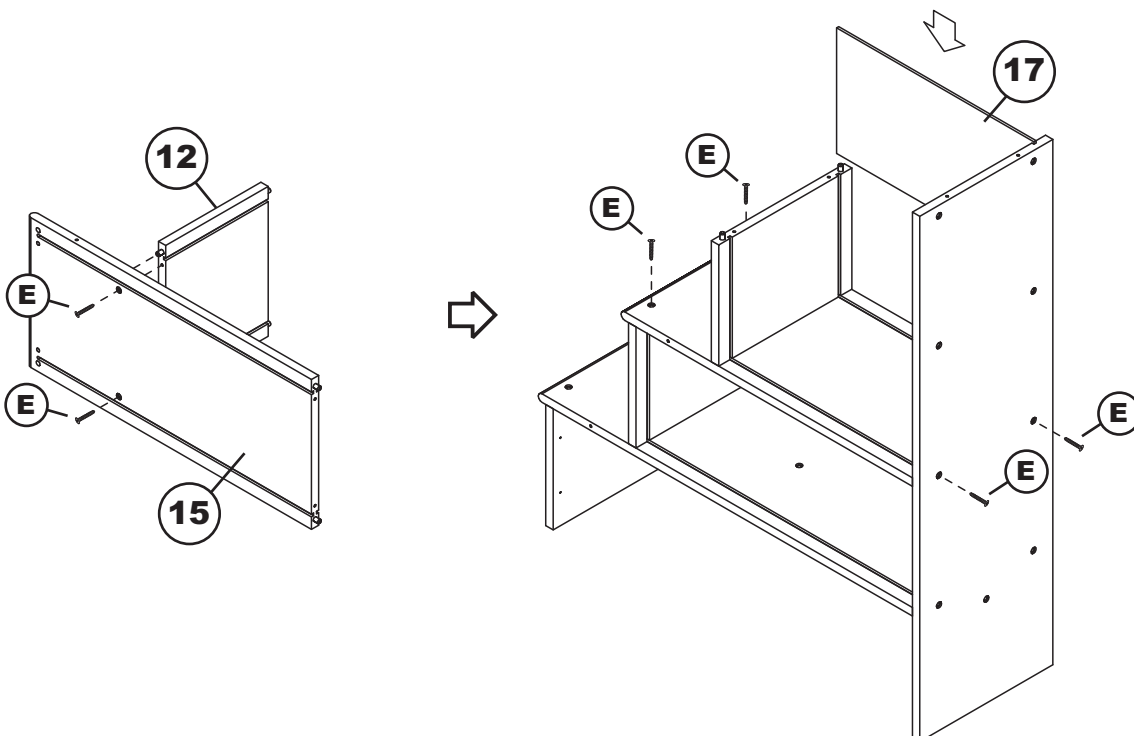

(TWIN - FULL)

STEP 13

Attach bookshelf top panel 2(17) to the bookshelf side panel (12) using allen screw (E). Tighten with allen wrench (M). But don't fully tighten these yet. Leave them a bit loose to make fitting the back panel easier.
Attach bookshelf top panel assemblies to the floor storage assemblies as shown below. Using allen screw (E). Tighten with allen wrench (M).
Install bookshelf back panel 3 (18).
After this, tighten allen screw of bottom section top panel 2.

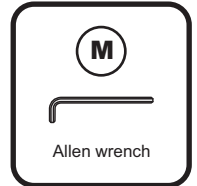
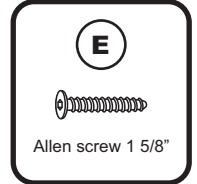
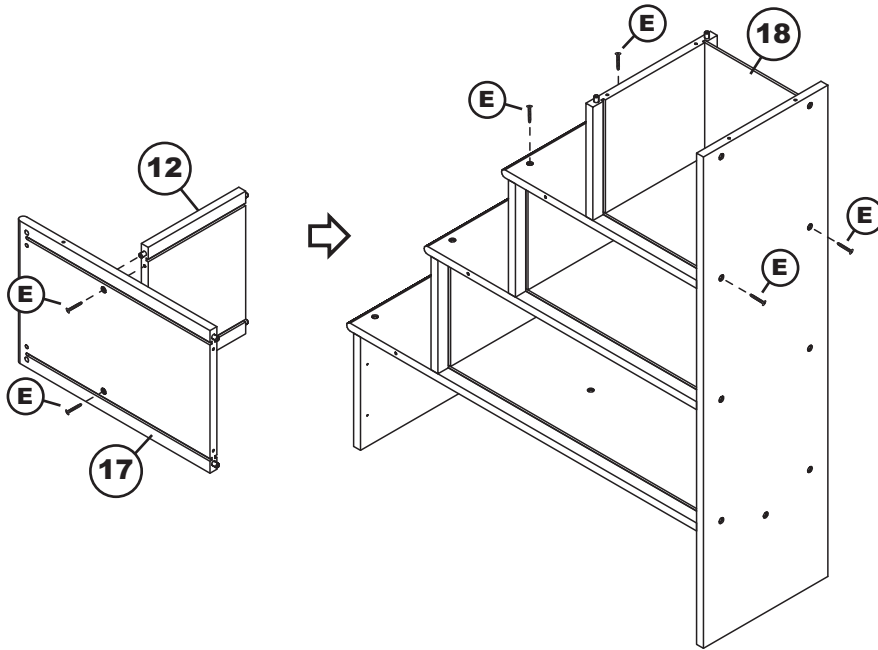

STEP 14

Attach bookshelf top panel 3 (19) to the floor storage assemblies. Using allen screw (E). Tighten with allen screw (M).
Attach back short guard rail (20) to the staircase bookshelf assemblies as shown below. Using allen screw (F). Tighten with allen wrench (M).

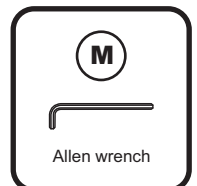
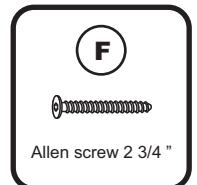
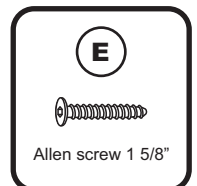
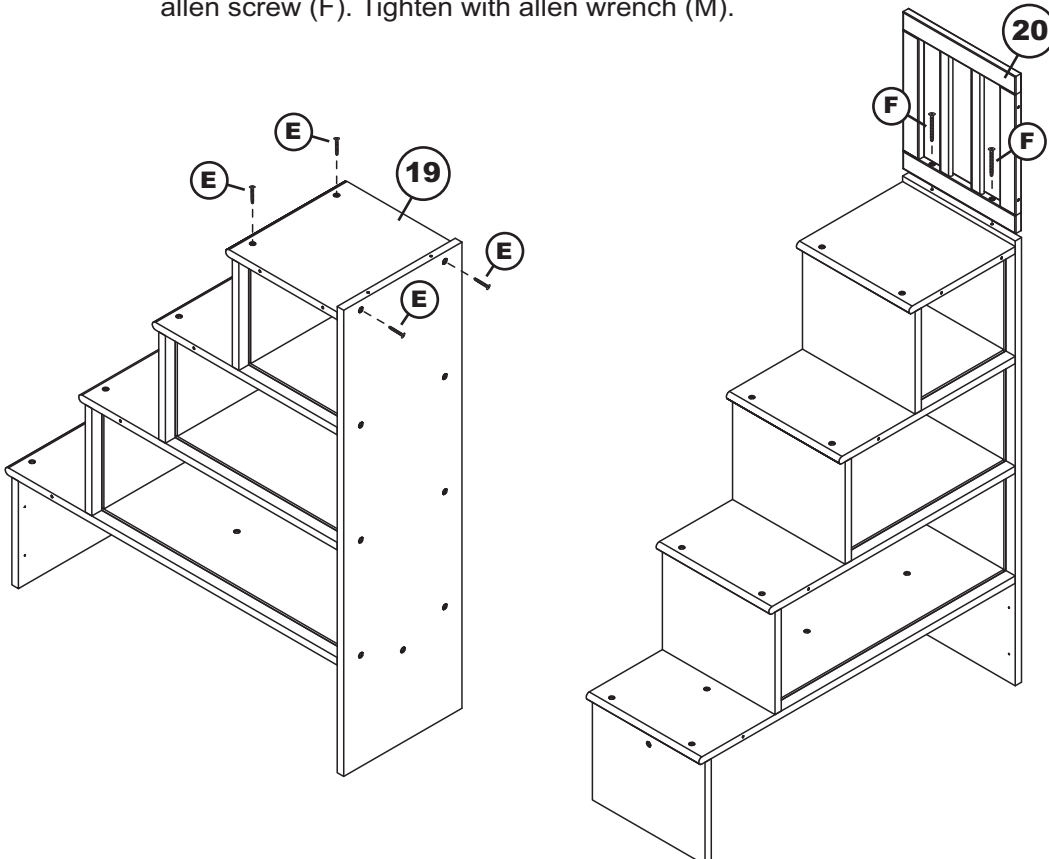

(TWIN - FULL)

STEP 15

Attach side short guard rail (21) to the staircase bookshelf assemblies. Using allen screw (E). Tighten with allen wrench (M).

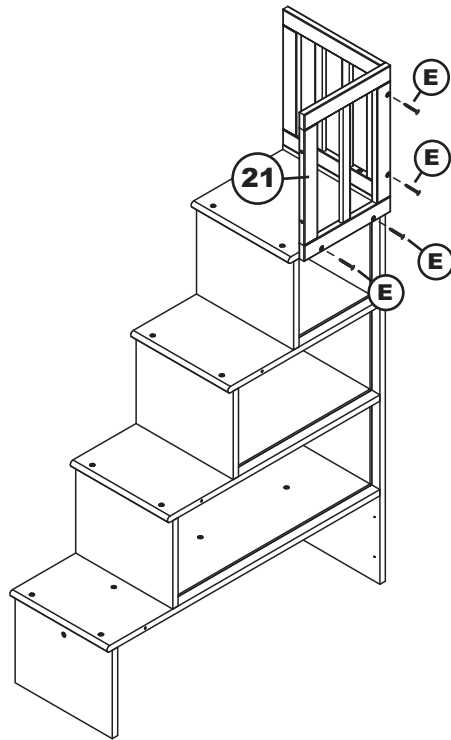

Adult assembly

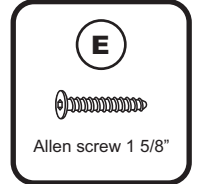

Allen screw 1 5/8"

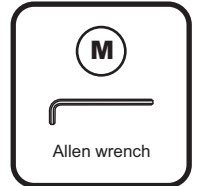

Allen wrench

STEP 16

Attach hand guard rail (22) to the staircase bookshelf assemblies. Using allen screw (E)(F). Tighten with allen wrench (M). Recheck that all screws are tight.

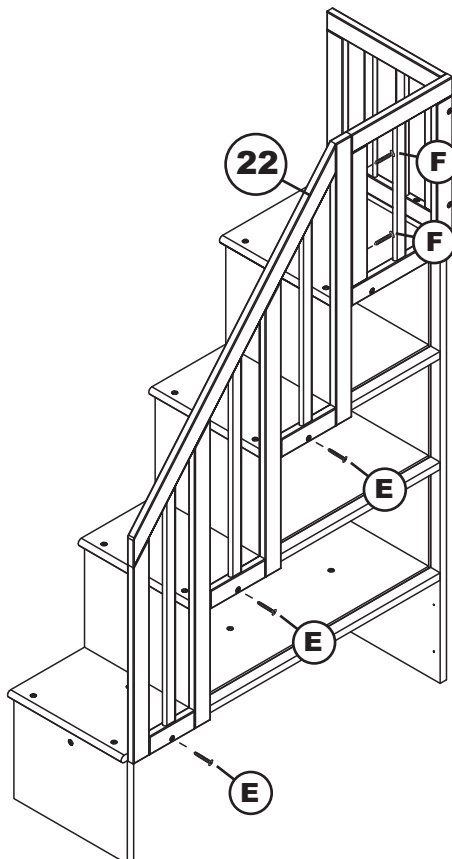

Adult assembly

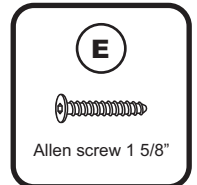

Allen screw 1 5/8"



Allen screw 2 3/4"

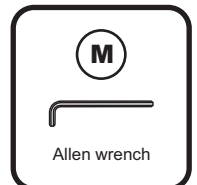

Allen wrench

(TWIN - FULL)

STEP 17

Move the bunk bed and staircase bookshelf assemblies where you want to place them in the room. Attach staircase bookshelf assembly to the bunk bed assembly as shown below. Fix L bracket (J) to upper, lower bunk panel using wood screws (I) as shown. Fix large L bracket (K) as shown. Cover holes with wood buttons (L). Lastly, Install USB charger (N) to the location as shown below. Using 1/2" screws and tighten with Phillips head screw driver. (Customer supplied)

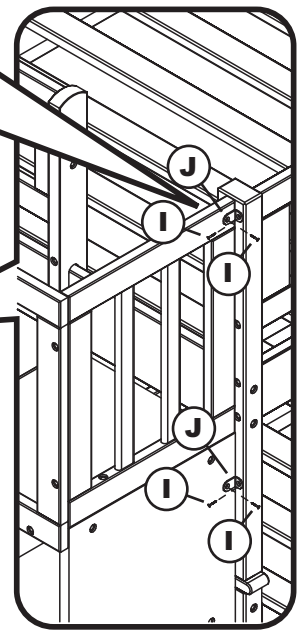
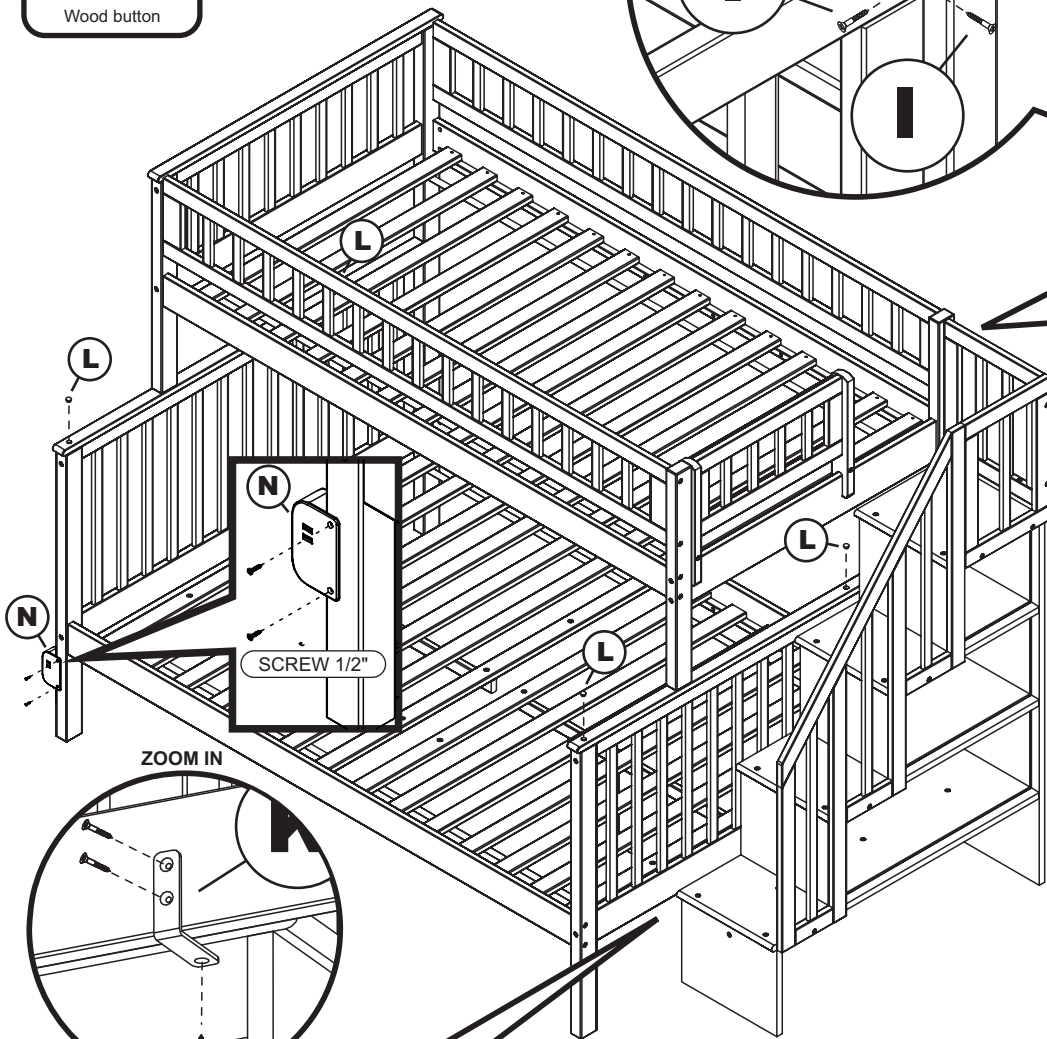
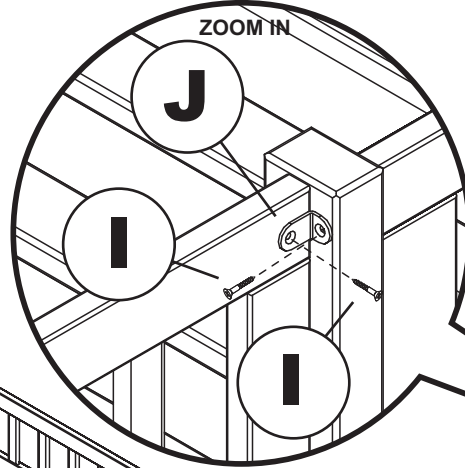
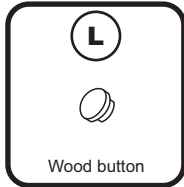
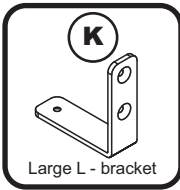
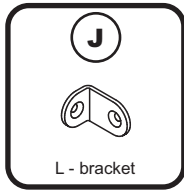

BACK VIEW

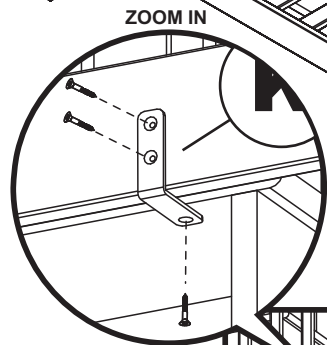

ZOOM IN

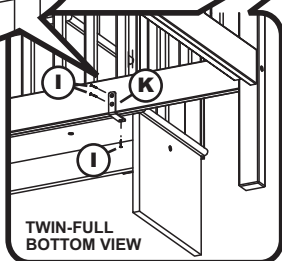

TWIN-FULL
BOTTOM VIEW

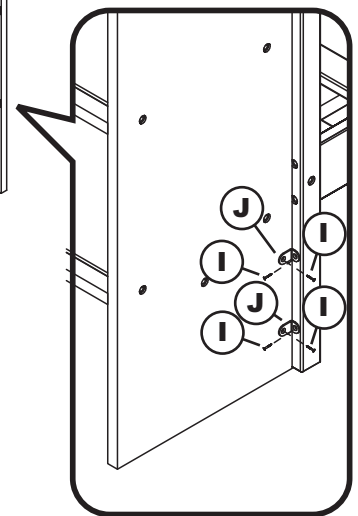

Congratulations!

Your staircase bookshelf bunk bed is now ready for use. We recommend that you periodically check that all screws are tight and all parts are secure to ensure lasting safety.

ASSEMBLY INSTRUCTIONS FULL

Before assembling your Trundle bed, please read through these instructions carefully. Familiarize yourself with the different parts.

ATTENTION! If you receive a damaged or defective item, please contact afifurnishings at customerservice@afifurnishings.com or 1-800-955-3726

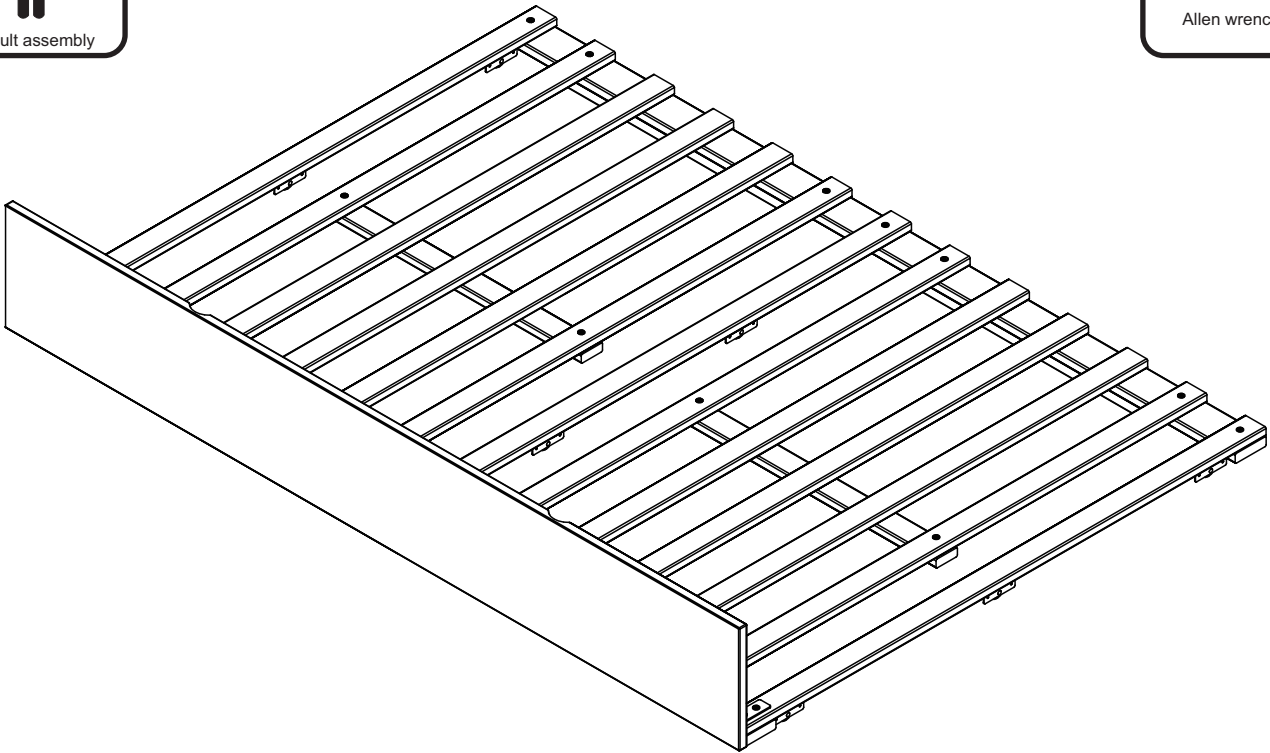
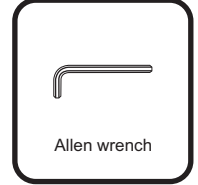

CODE	ITEM
ST-TD-UBN	E-6713X

PO :

HARDWARE

NOTE: WE INCLUDE SPARE HARDWARE IN CASE DAMAGE OCCURS DURING ASSEMBLY.

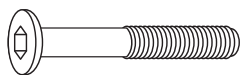
A  JCB M6 X 1 5/8" (40mm) - 21 pcs
Spare - 1 pc

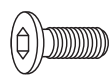
B  JCB M6 X 5/8" (15mm) - 6 pcs
Spare - 1 pc
Fix L bracket to front panel

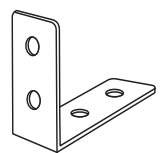
C  L Bracket - 3 pcs

D  Allen wrench - 1 pc
Spare - 1 pc

FULL

PARTS LIST

01	HARDWARE	1 BOX	05	SIDE CROSS RAIL	2 PCS
02	FRONT PANEL	1 PC	06	CENTER CROSS RAIL	1 PC
03	FRONT RAIL	1 PC	07	SLAT KIT	2 SET
04	BACK RAIL	1 PC	08	CENTER SLAT SUPPORT	2 PCS

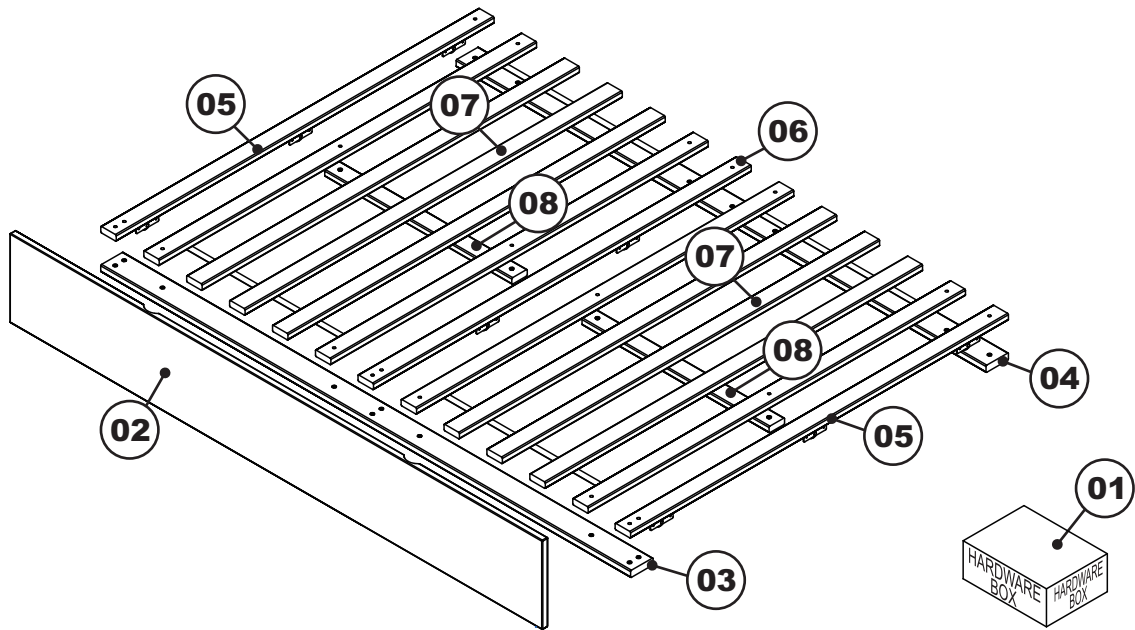

Step 1

Attach the side cross rails (05) and center cross rail (06) to the front and back rail (03)(04), using L bracket (C), JCB M6 X 1 5/8" (A). Tighten with the Allen wrench (D).

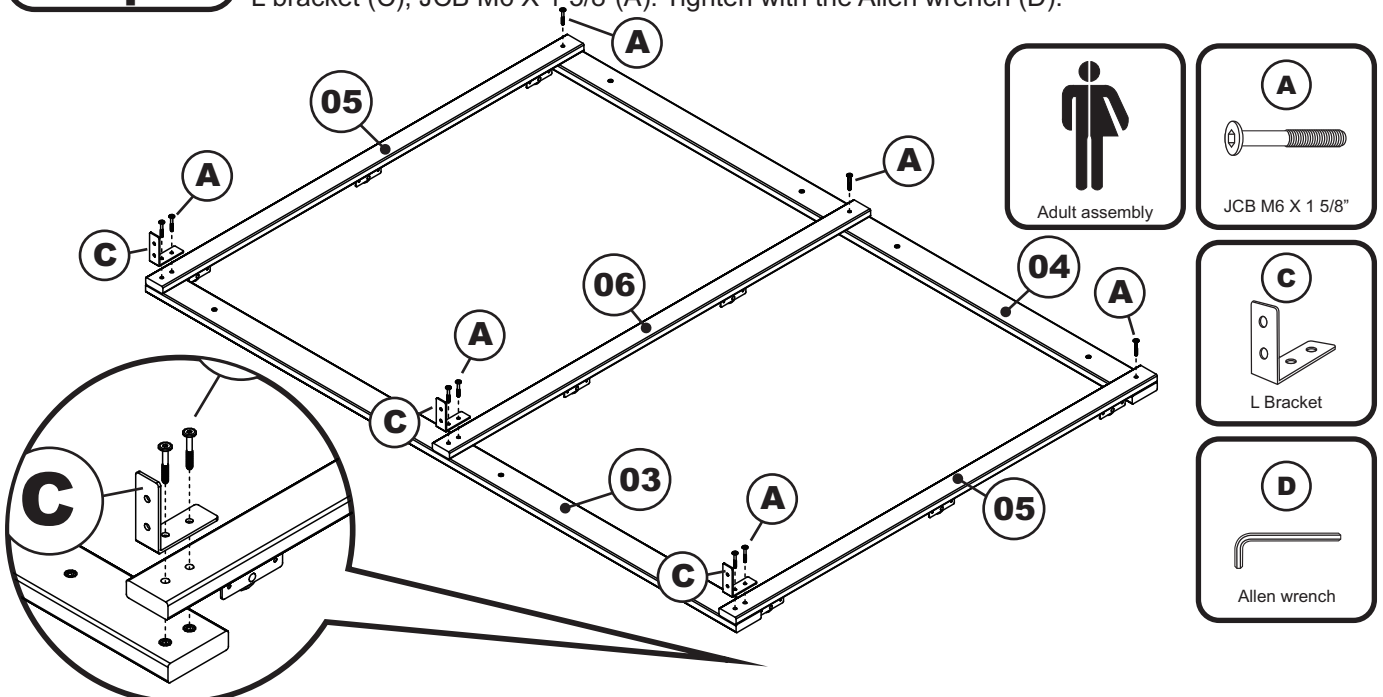

FULL

Step 2

Attach the front panel (02) to the front rail as shown, using JCB M6 X 5/8" (B). Tighten with the Allen wrench (D).

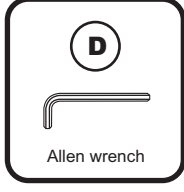
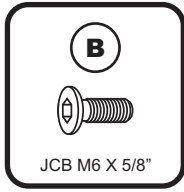
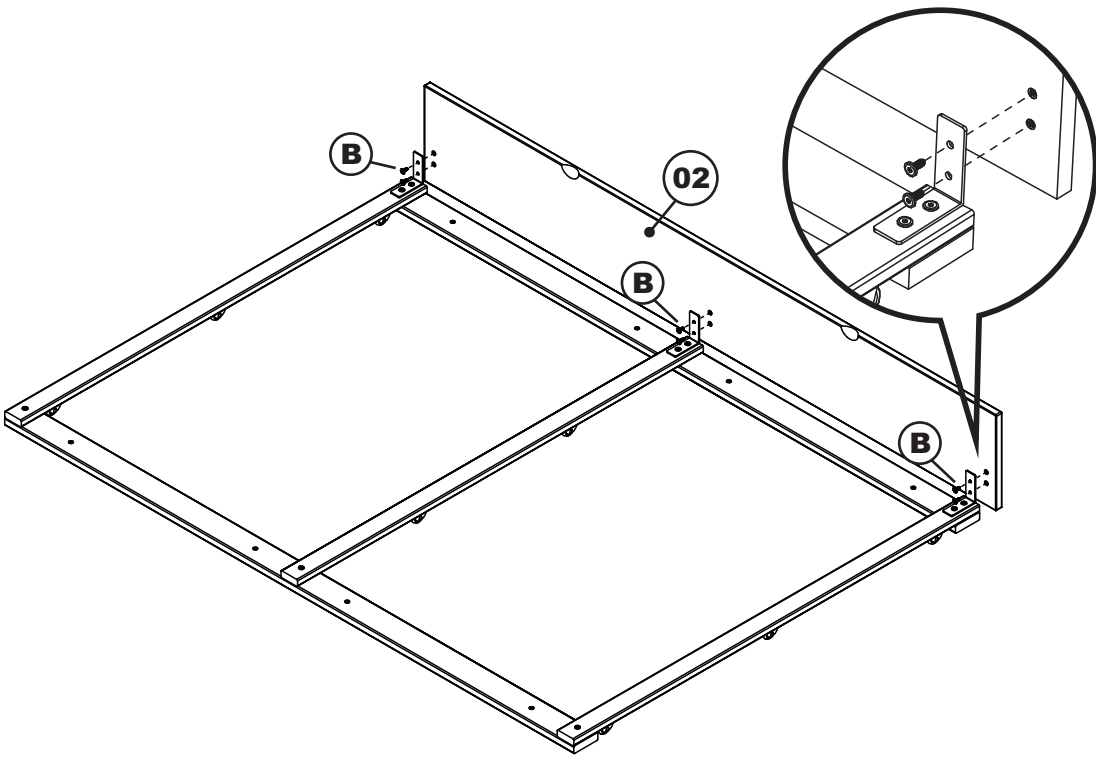

Step 3

Attached center slat support(08) to the slat kit (07) as shown, using JCB M6 X 1 5/8" (A). Tighten with the Allen wrench (D).

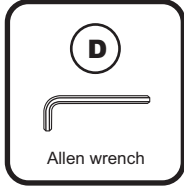
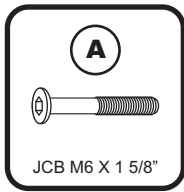
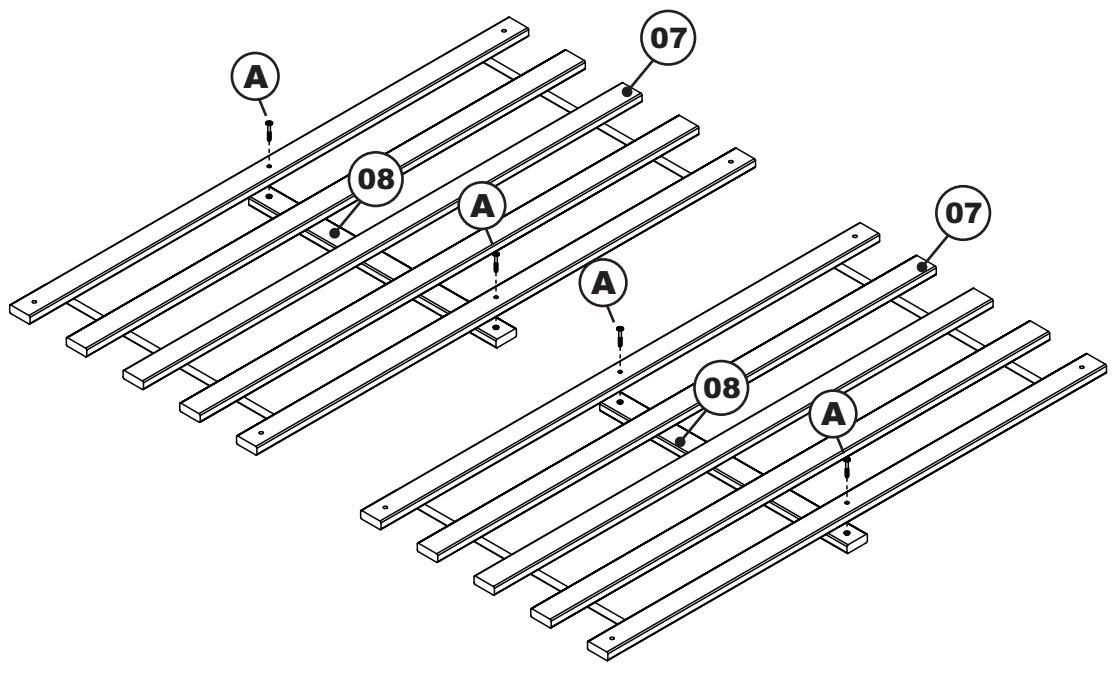

FULL

Step 4

Lay the slat kit (07) onto the rail assembly as shown, using JCB M6 X 1 5/8" (A). Tighten with the Allen wrench (D).

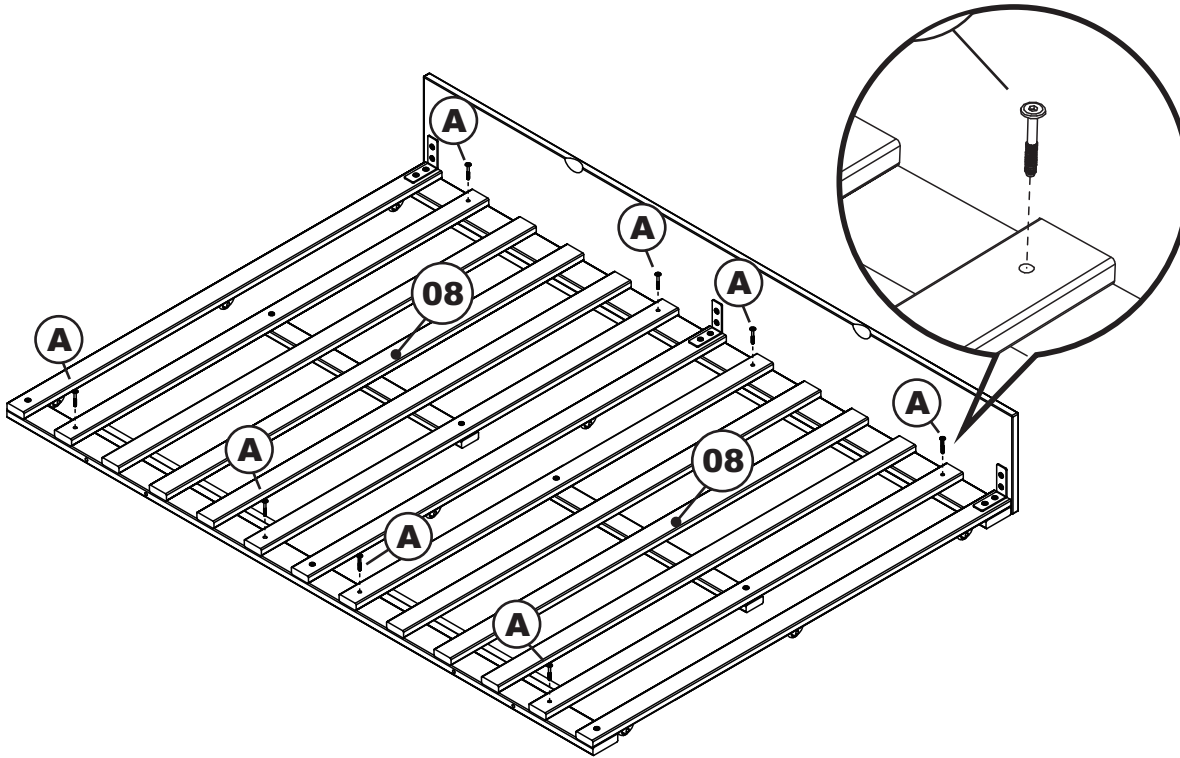

Adult assembly

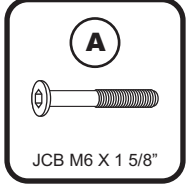

JCB M6 X 1 5/8"

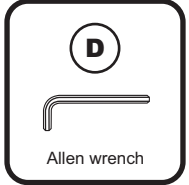

Allen wrench

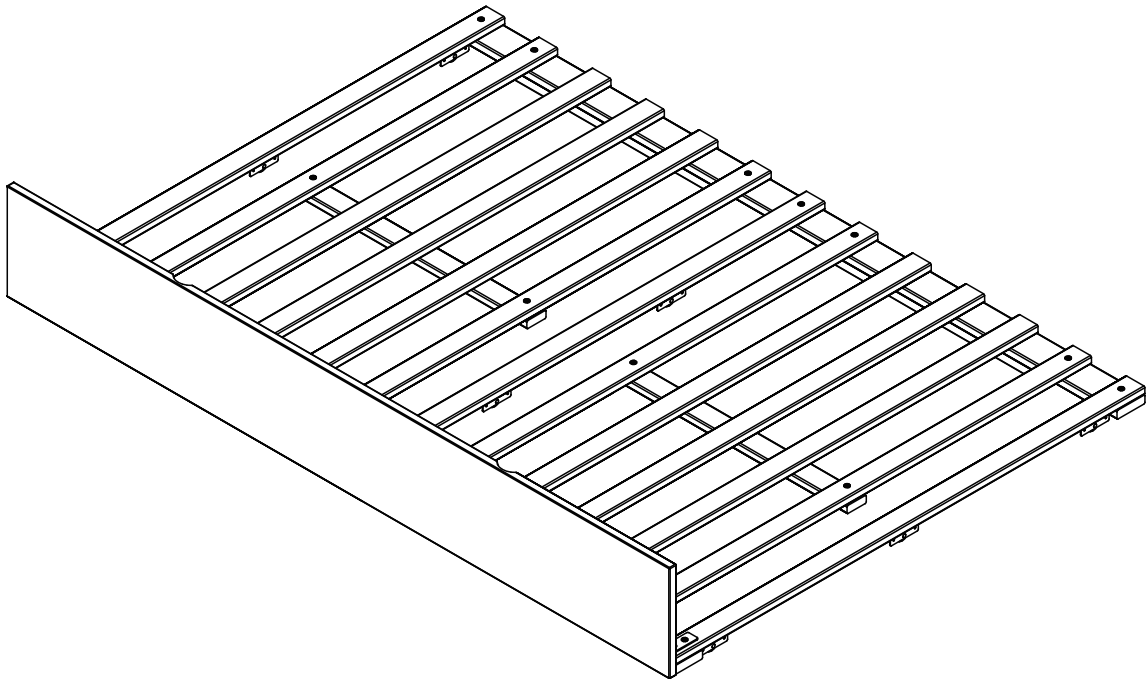

Congratulations!

Your Trundle bed is now ready for use.
We recommend that you periodically check that all screws are tight and all parts are secure to ensure lasting safety.