

COASTER[®]
FINE FURNITURE

122060

29 " BAR CHAIR



www.coastercompany.com

2011/08/08

Assembly Instruction













ASSEMBLY TIPS:

1. Remove hardware from box and sort by size.
2. Please check to see that all hardware and parts are present prior to start of assembly.
3. Please follow attached instructions in the same sequence as numbered to assure fast & easy assembly.



Warning !

1. Don't attempt to repair or modify parts that are broken or defective. Please contact the store immediately
2. This product is for home use only and not intended for commercial establishment.

PARTS IDENTIFICATION		Z	HARDWARE IDENTIFICATION	
			DESCRIPTION	FIGURE Q' TY
A	legs  4PCS	1	1/4 "× 12mm ALLEN BOLT-SMALL	 24 PCS
B	circle  1PC	2	1/4 "× 15mm ALLEN BOLT-MEDIUM	 3 PCS
		3	1/4 "× 30mm ALLEN BOLT-LARGE	 2 PCS
C	frame 1  1PC	4	4 × 30mm SCREW	 4 PCS
		5	4mm ALLEN WRENCH	 1PC
D	frame 2  1PC			
E	plate  1PC			
F	back  1PC			
G	cushion  1PC			

ITEM: 122060

ASSEMBLY INSTRUCTION

STEP 1.

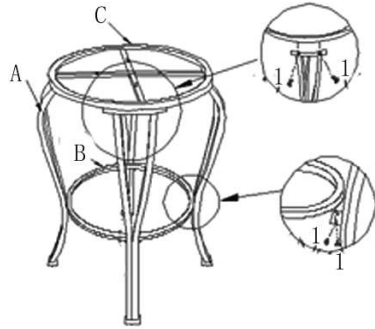

STEP 2.

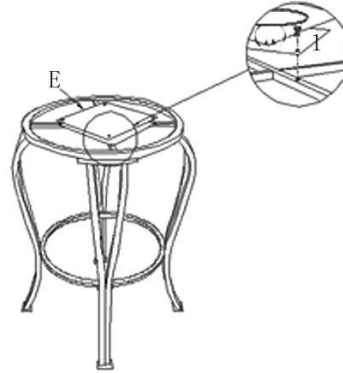

STEP 3.

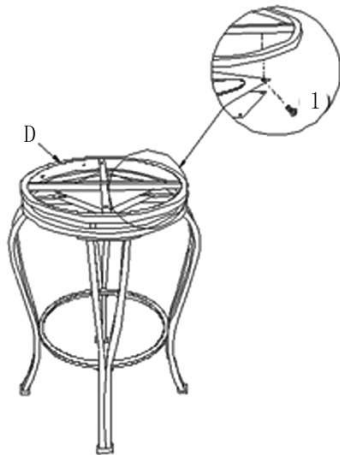

STEP 4.

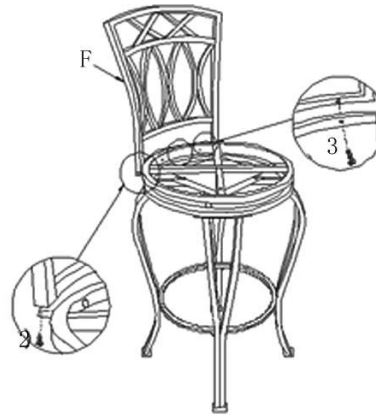

STEP 5.

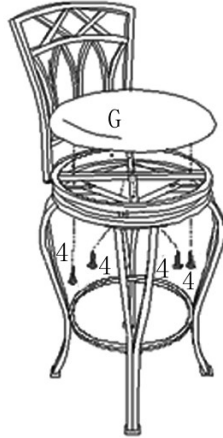

STEP 6.



Step 1: Assemble the legs (A) with seat frame (C) using small Allen bolts (1). Then, affix the circle footrest (B) to the inside of legs (A) using small Allen bolts (1).

Step 2: Affix the swivel plate (E) onto seat frame (C) using small Allen bolts (1).

Step 3: Place the remaining seat frame (D) onto swivel plate (E) and secure using small Allen bolts (1).

Step 4: Attach the seat back (F) to seat frame (D) using medium Allen bolts (2) to screw upwards into the back, and the 3 large Allen bolts (3) to screw into the bottom crossbar of the back.

Step 5: Affix the seat cushion (G) with the seat frame (D) using the screws (4).

Step 6: Tighten all the screws and the product is finished.