

ASSEMBLY INSTRUCTIONS
COASTER FINE FURNITURE



Fine Furniture for every stage of life

802041
Writing Desk

ITEM: **802041**



ASSEMBLY INSTRUCTIONS

ASSEMBLY TIPS:

1. Remove hardware from box and sort by size.
2. Please check to see that all hardware and parts are present prior to start of assembly.
3. Please follow attached instructions in the same sequence as numbered to assure fast & easy assembly.



WARNING!



1. Don't attempt to repair or modify parts that are broken or defective. Please contact the store immediately.
2. This product is for home use only and not intended for commercial establishments.



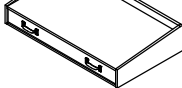
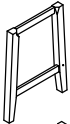
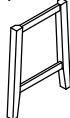

ASSEMBLY TIME

30 MINUTES

PARTS IDENTIFICATION

A	TOP PANEL		1PC
B	LEFT LEG FRAME		1PC
C	RIGHT LEG FRAME		1PC
D	CROSSBAR		1PC

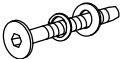
HARDWARE IDENTIFICATION

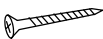
1	ALLEN WRENCH (M4 x 110mm- BLK)		1PC
2	BOLT WITH WASHER (M6 x 60mm - BLK)		4PCS
3	WOOD DOWEL (M8 x 30mm)		2PCS
4	FLAT HEAD SCREW (M4 x 38mm - BLK)		2PCS

NOTE:

Phillips head screw driver is required in the assembly process; however, manufacturer does not provide this item.

ITEM: **802041**

ASSEMBLY INSTRUCTIONS

STEP 1

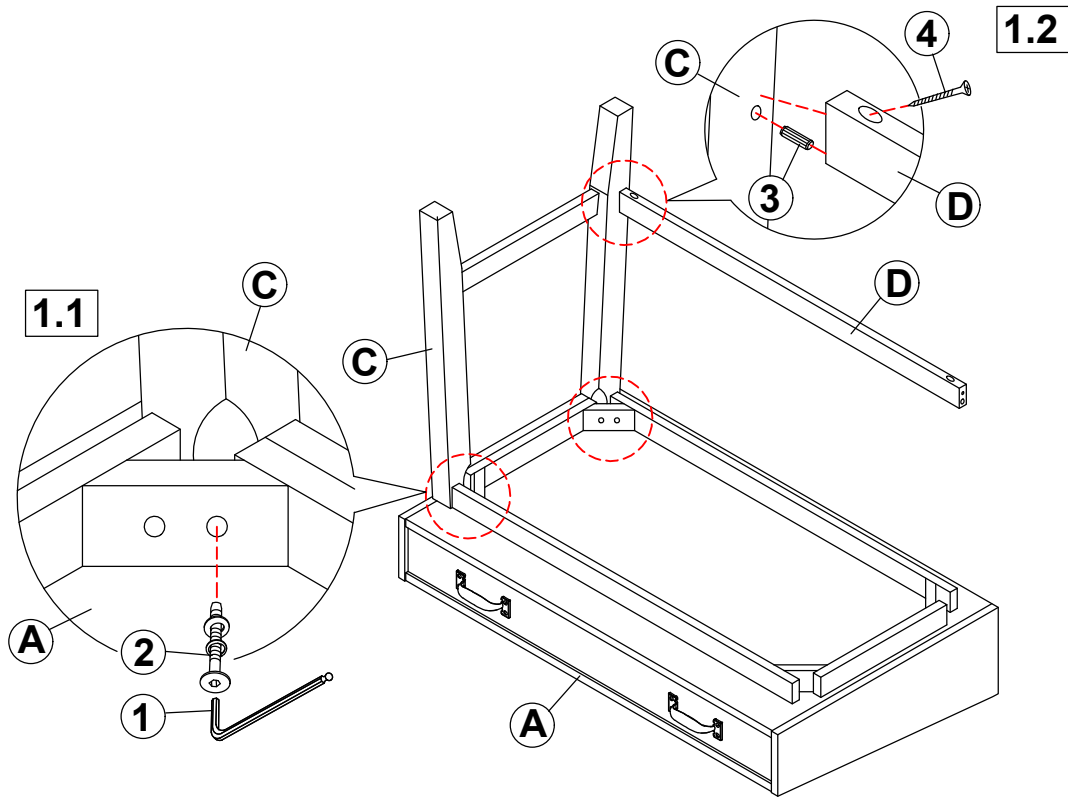

STEP 2

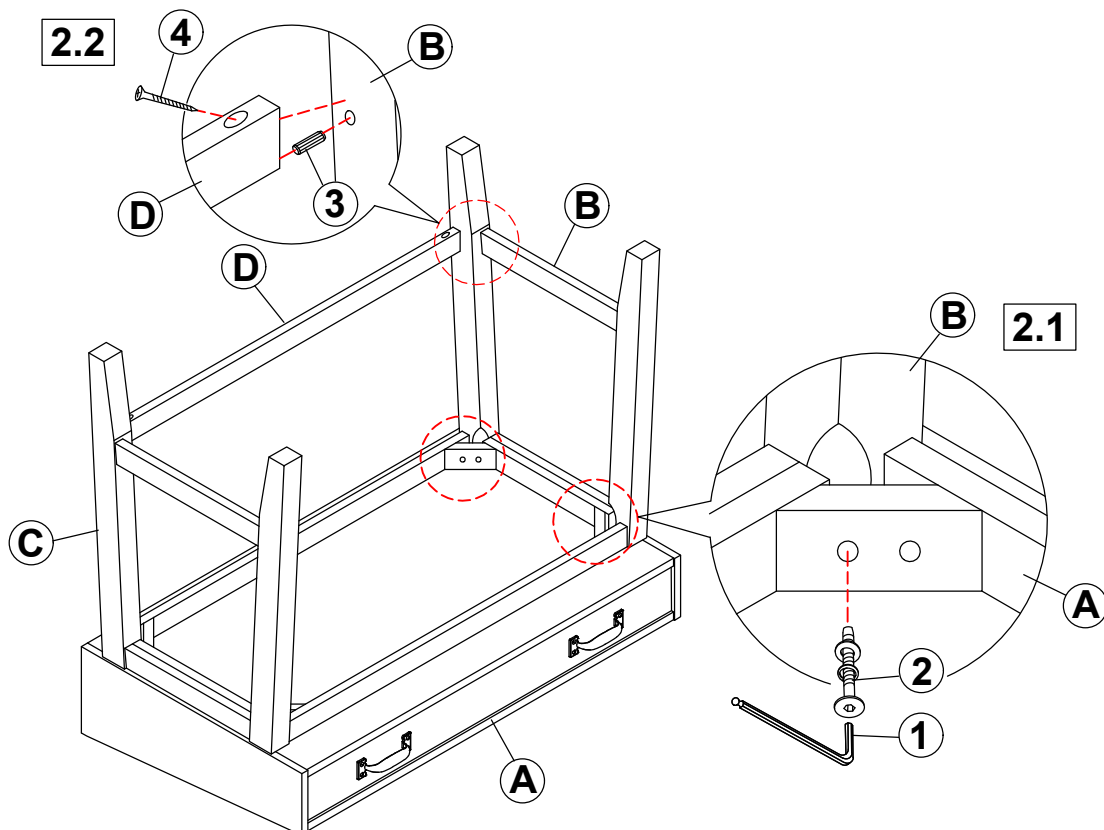

ITEM: **802041**

ASSEMBLY INSTRUCTIONS

STEP 3

COMPLETE

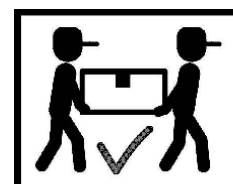
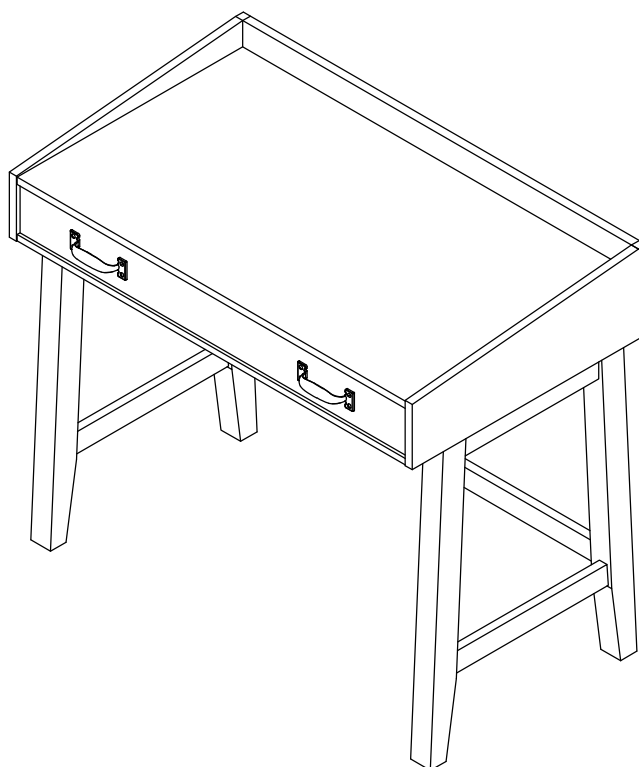

ITEM: **802041**



Inner Size of Drawer : 34.50"W x 12.50"D x 2.75"H x 0.50"T

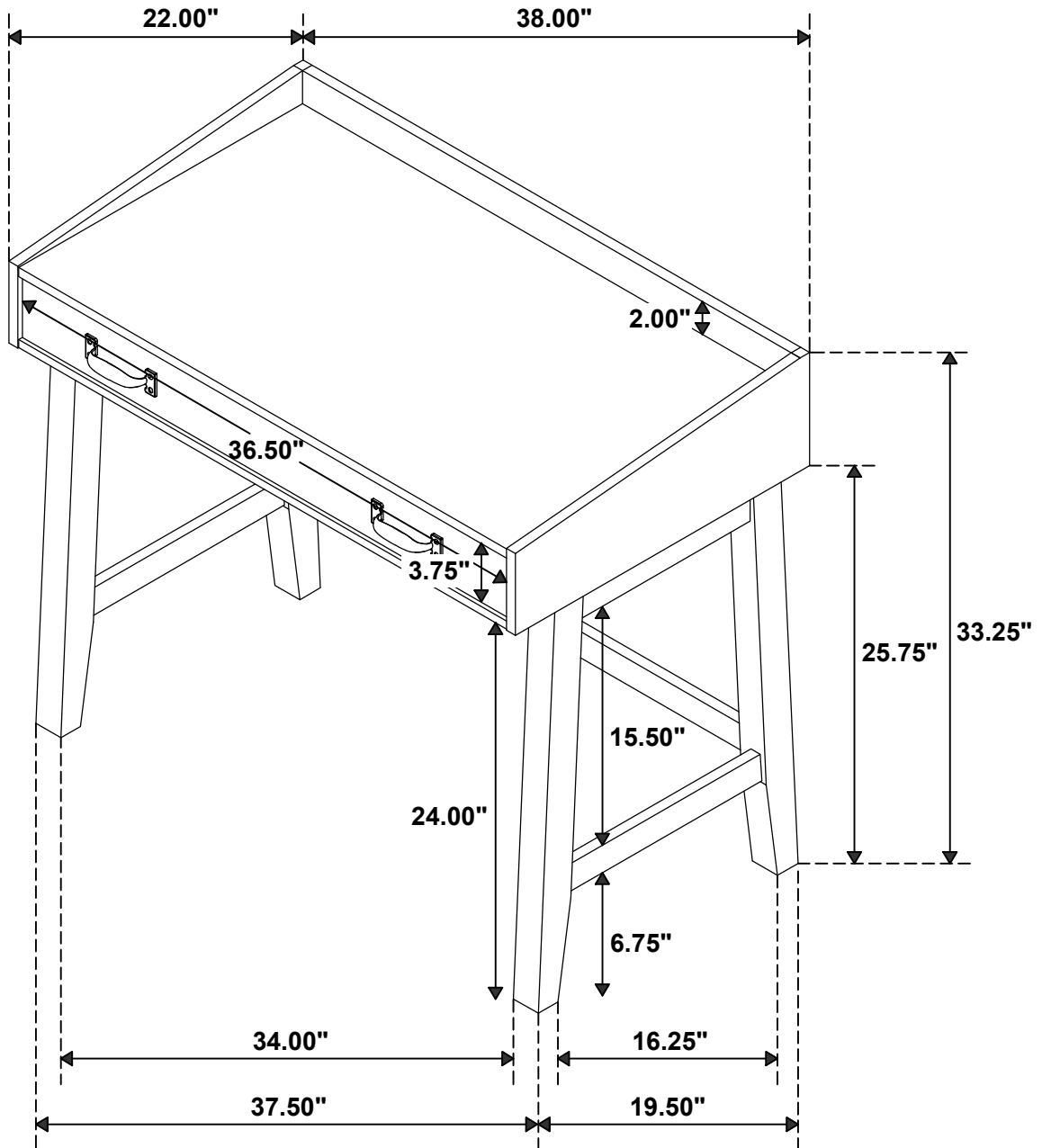

Note : Dimension tolerance $\pm 5\%$

ASSEMBLY INSTRUCTIONS COASTER FINE FURNITURE



Fine Furniture for every stage of life

802043 (B1&B2)
Bookshelves

ITEM: 802043 (B1&B2)



ASSEMBLY INSTRUCTIONS

ASSEMBLY TIPS:

1. Remove hardware from box and sort by size.
2. Please check to see that all hardware and parts are present prior to start of assembly.
3. Please follow attached instructions in the same sequence as numbered to assure fast & easy assembly.



WARNING!

1. Don't attempt to repair or modify parts that are broken or defective. Please contact the store immediately.
2. This product is for home use only and not intended for commercial establishments.



ASSEMBLY TIME

30 MINUTES

PARTS IDENTIFICATION

B1 (BOX 1)

A LEFT SIDE FRAME

2PCS

B RIGHT SIDE FRAME

2PCS



B2 (BOX 2)

C DRAWER UNIT

2PCS

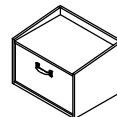

D TOP SHELF

2PCS

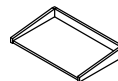

E MIDDLE SHELF

2PCS

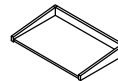

F BOTTOM SHELF

2PCS

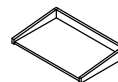

G CROSSBAR

2PCS



H FLAT SUPPORT BAR

2PCS



ITEM: 802043 (B1&B2)



ASSEMBLY INSTRUCTIONS

ASSEMBLY TIPS:

1. Remove hardware from box and sort by size.
2. Please check to see that all hardware and parts are present prior to start of assembly.
3. Please follow attached instructions in the same sequence as numbered to assure fast & easy assembly.







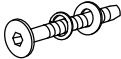

WARNING!

1. Don't attempt to repair or modify parts that are broken or defective. Please contact the store immediately.
2. This product is for home use only and not intended for commercial establishments.

HARDWARE IDENTIFICATION

Z-B1 (BOX 1) - HARDWARE PACK IS LOCATED IN 802043 (B1)

1	ALLEN WRENCH (M4 x 110mm - BLK)		1PC
2	BOLT WITH WASHER (M6 x 60mm - BLK)		4PCS
3	PLASTIC U WASHER (6.5 x 15 x 5.8mm - BLK)		4PCS
4	WOOD DOWEL (M8 x 30mm)		8PCS
5	FLAT HEAD SCREW (M3.5 x 16mm - BLK)		72PCS
6	L BRACKET (C35 - BLK)		36PCS
7	CLIP		4PCS

NOTE:

Phillips head screw driver is required in the assembly process; however, manufacturer does not provide this item.

ITEM: **802043 (B1&B2)**



ASSEMBLY INSTRUCTIONS

STEP 1

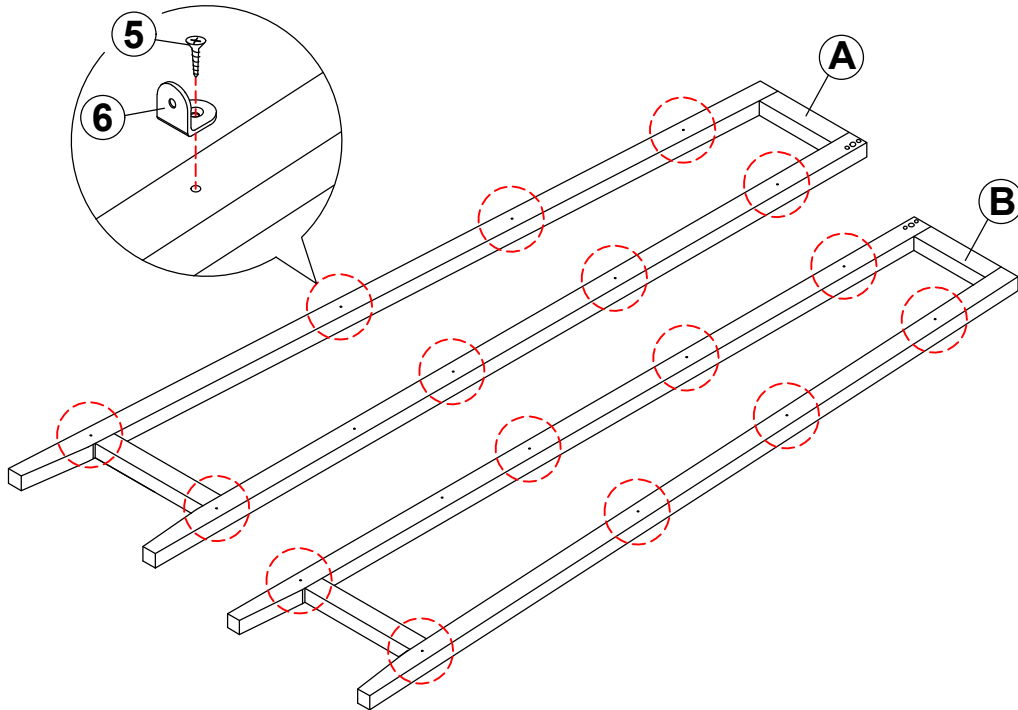

STEP 2

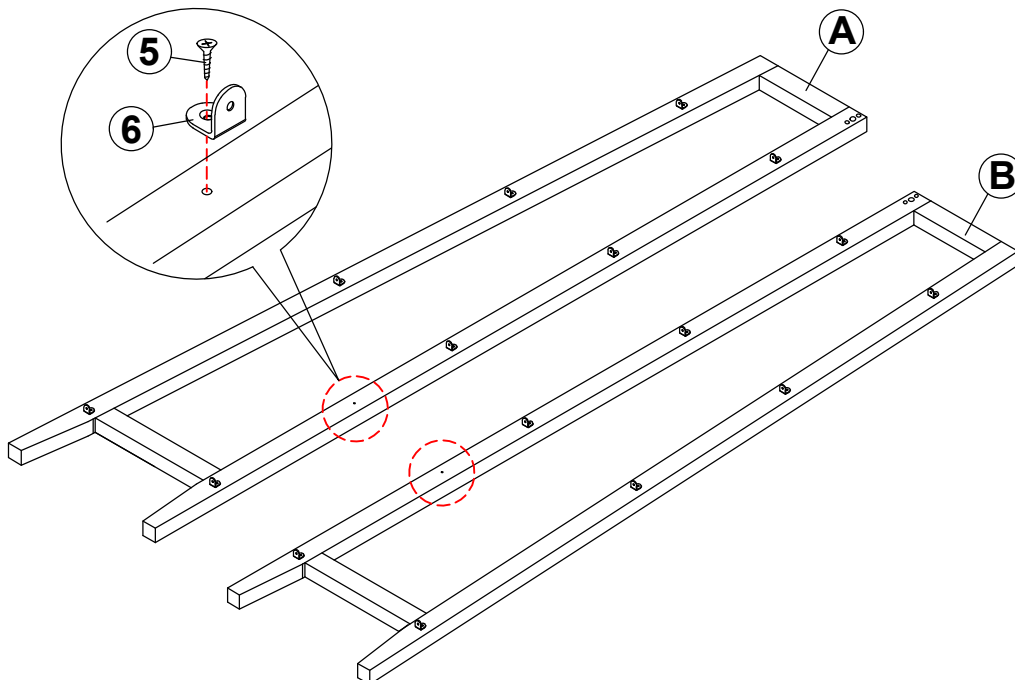

ITEM: **802043 (B1&B2)**



ASSEMBLY INSTRUCTIONS

STEP 3

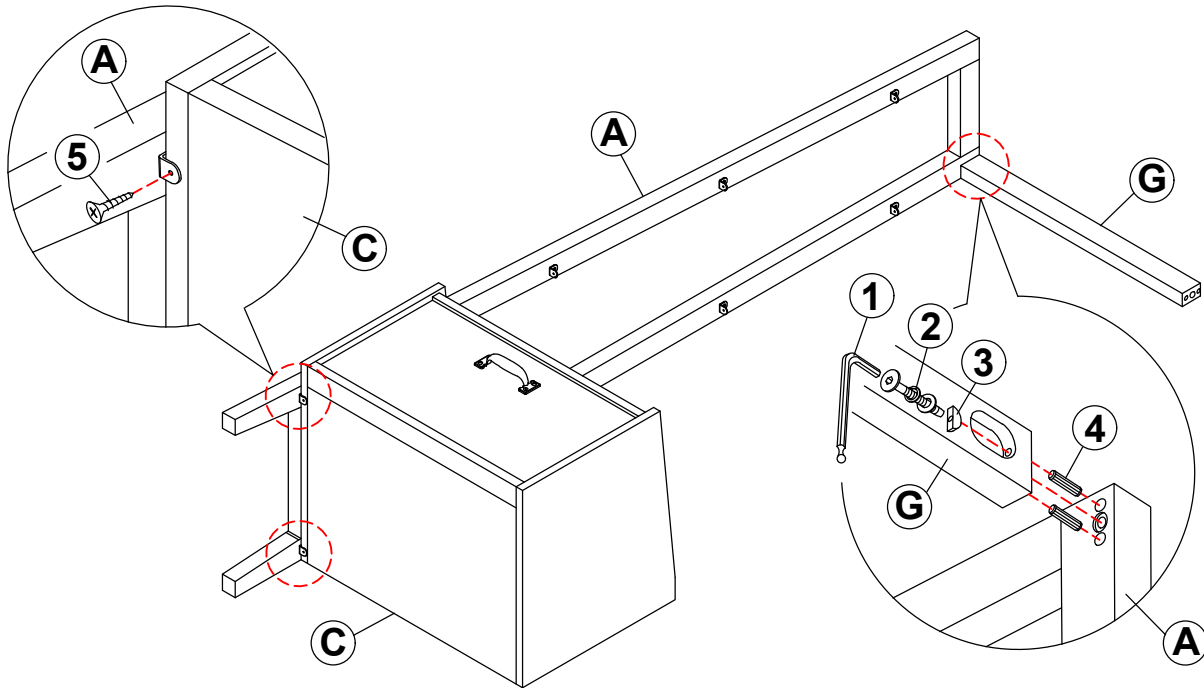

STEP 4

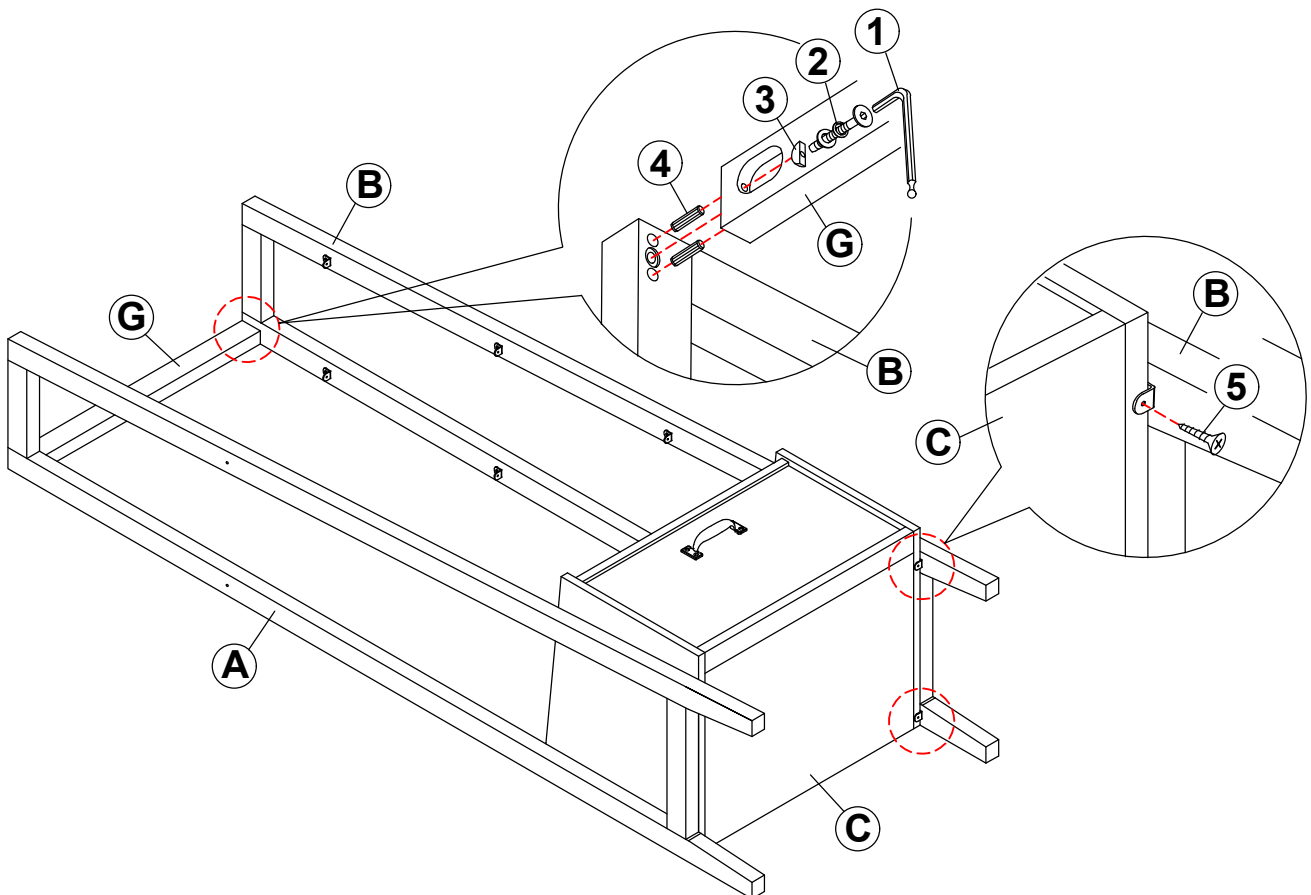

ITEM: **802043 (B1&B2)**

ASSEMBLY INSTRUCTIONS

STEP 5

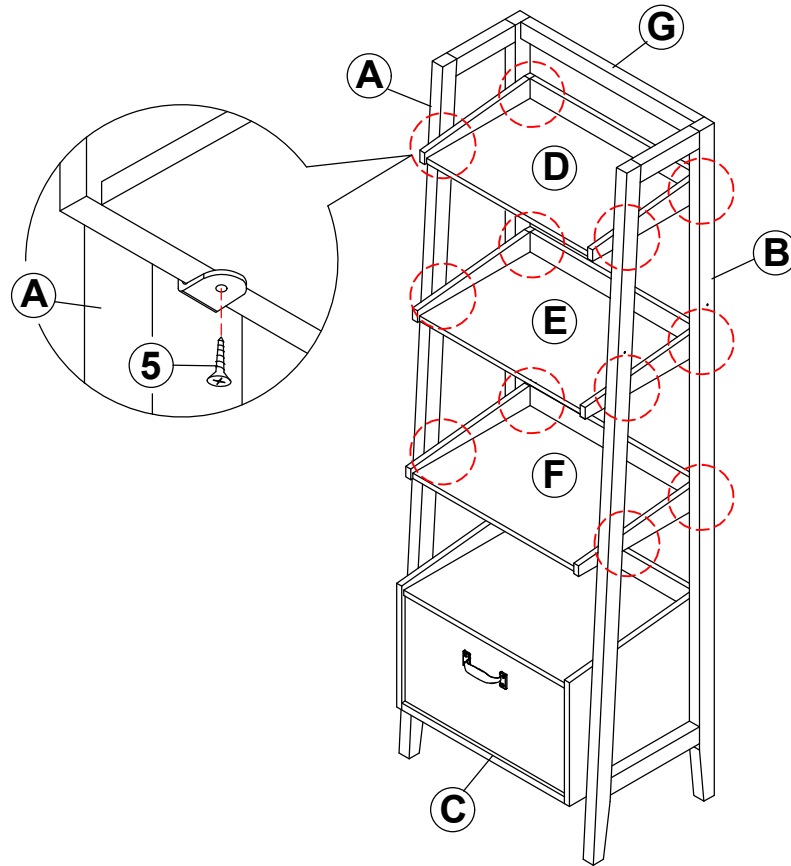

STEP 6

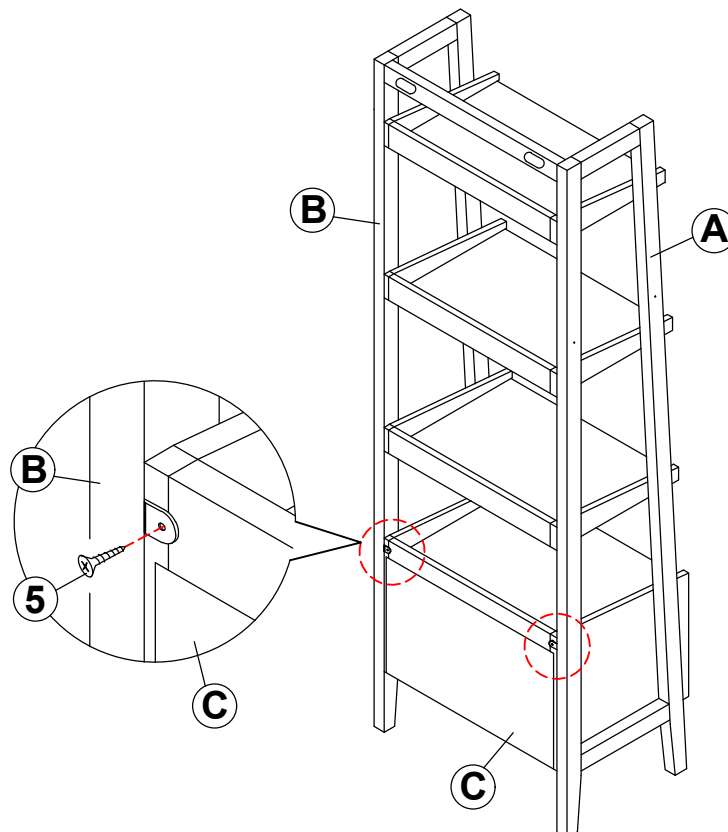

ITEM: **802043 (B1&B2)**



ASSEMBLY INSTRUCTIONS
STEP 7

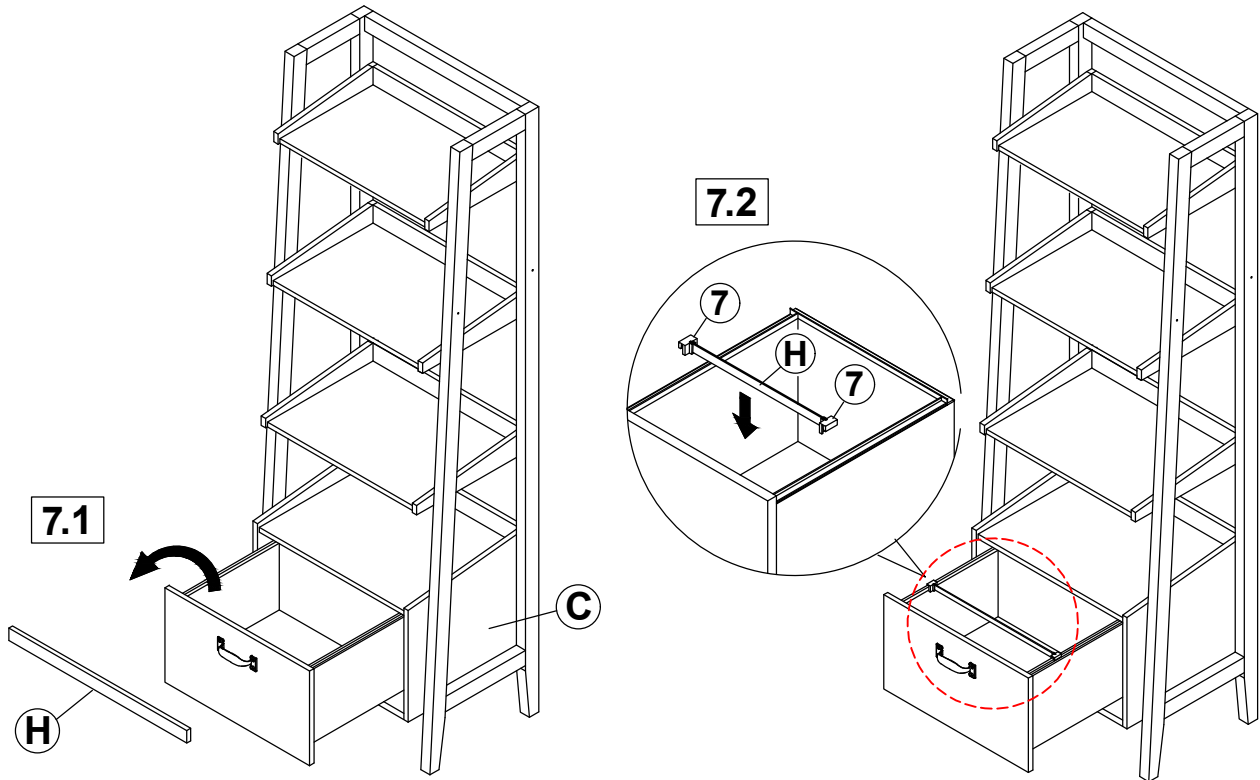

STEP 8
COMPLETE

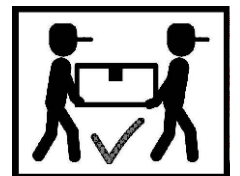
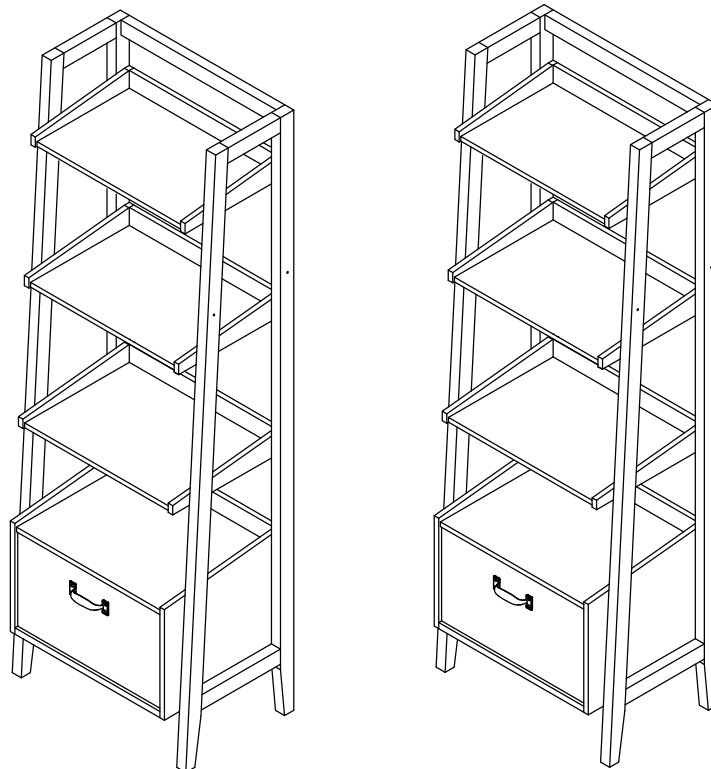

ITEM: 802043 (B1&B2)



Inner Size of Drawer : 18.00"W x 14.00"D x 8.50"H x 0.50"T

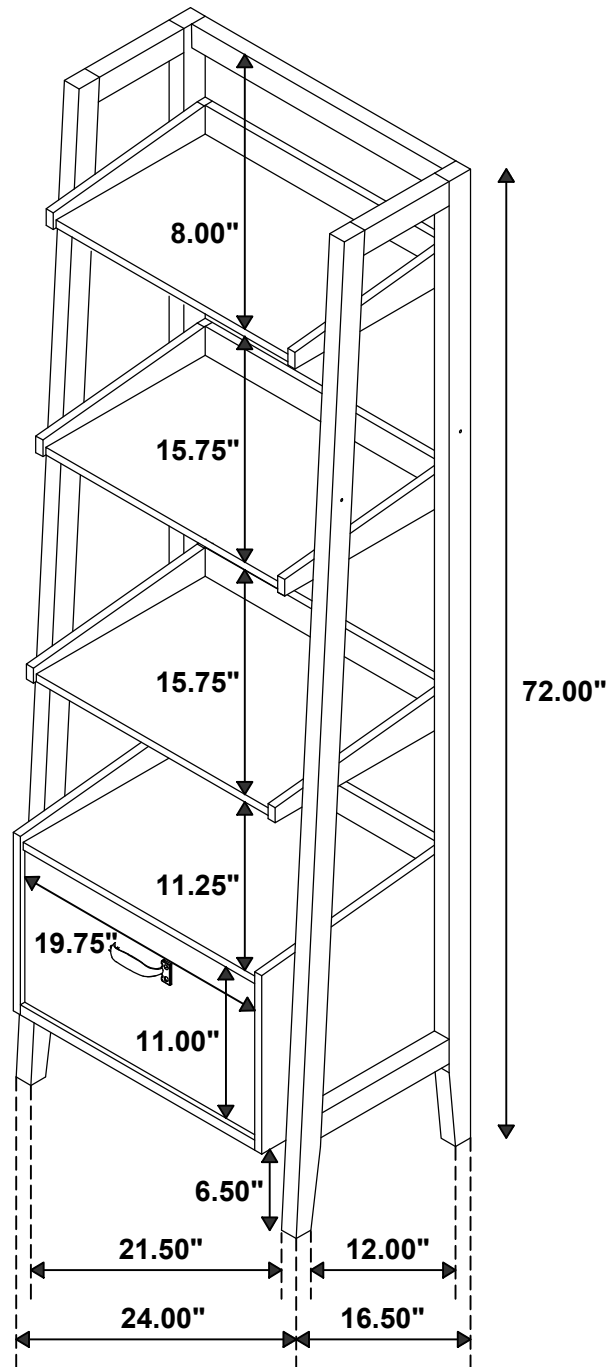

Note : Dimension tolerance $\pm 5\%$

ASSEMBLY INSTRUCTIONS COASTER FINE FURNITURE

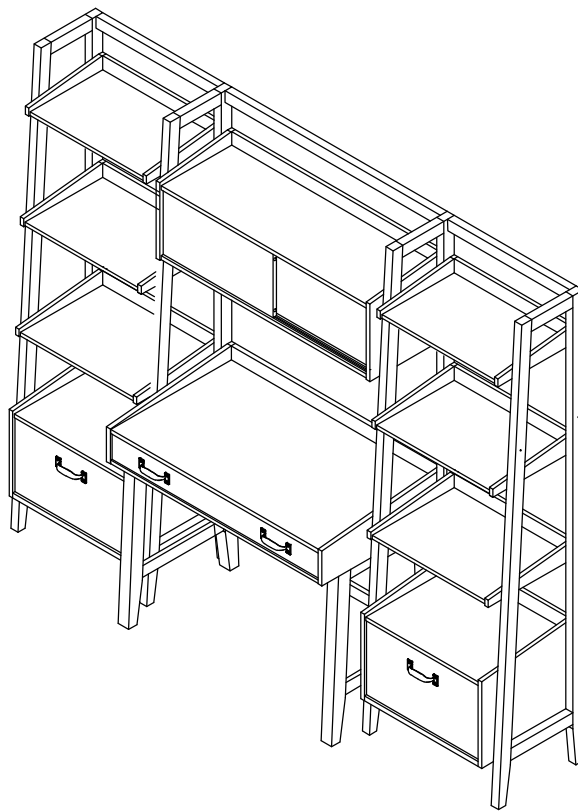

Fine Furniture for every stage of life

802044 *Center Bridge With Storage Cabinets*

ITEM: **802044**



ASSEMBLY INSTRUCTIONS

ASSEMBLY TIPS:

1. Remove hardware from box and sort by size.
2. Please check to see that all hardware and parts are present prior to start of assembly.
3. Please follow attached instructions in the same sequence as numbered to assure fast & easy assembly.



WARNING!

1. Don't attempt to repair or modify parts that are broken or defective. Please contact the store immediately.
2. This product is for home use only and not intended for commercial establishments.



ASSEMBLY TIME

30 MINUTES

PARTS IDENTIFICATION

A STORAGE CABBIES

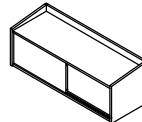

1PC

B BACK RAIL



1PC

C BOOKSHELVES
*FROM BOX ITEM #802043

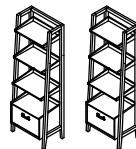

1PC

D WRITING DESK
*FROM BOX ITEM #802041



1PC

HARDWARE IDENTIFICATION

1 L BRACKET
(C35 - BLK)



4PCS

2 FLAT HEAD SCREW
(M3.5 x 16mm - BLK)



8PCS

3 PAN HEAD SCREW
(M4 x 16mm - BLK)



8PCS

4 PLATE
(3 x 25 x 90mm - BLK)

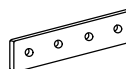

2PCS

NOTE:

Phillips head screw driver is required in the assembly process; however, manufacturer does not provide this item.

ITEM: **802044**



ASSEMBLY INSTRUCTIONS

STEP 1

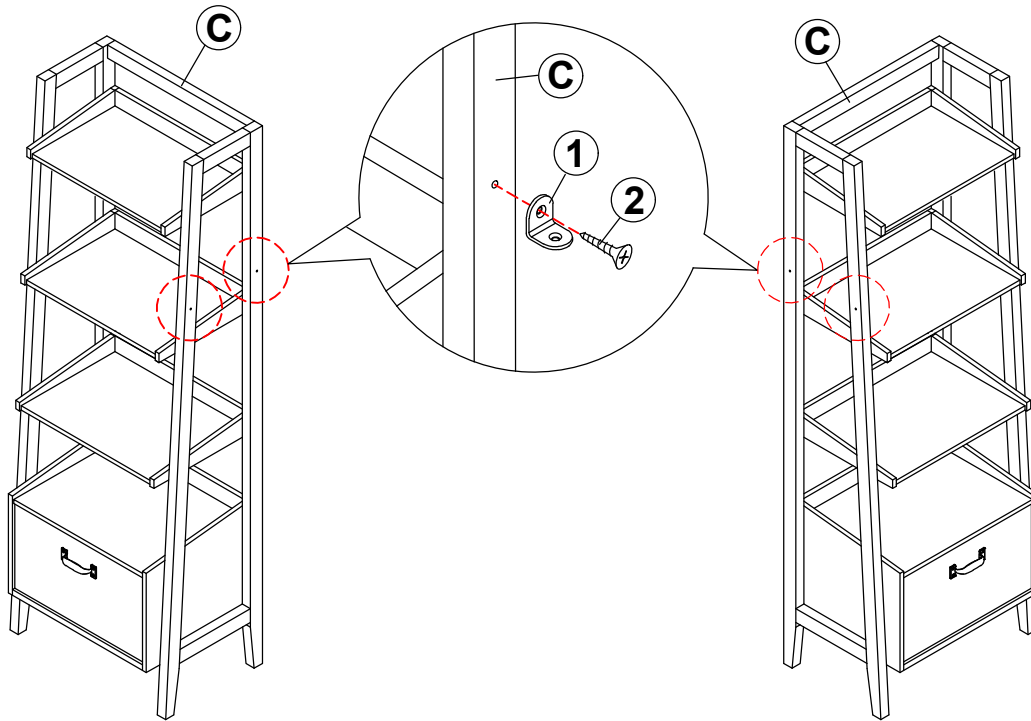

STEP 2

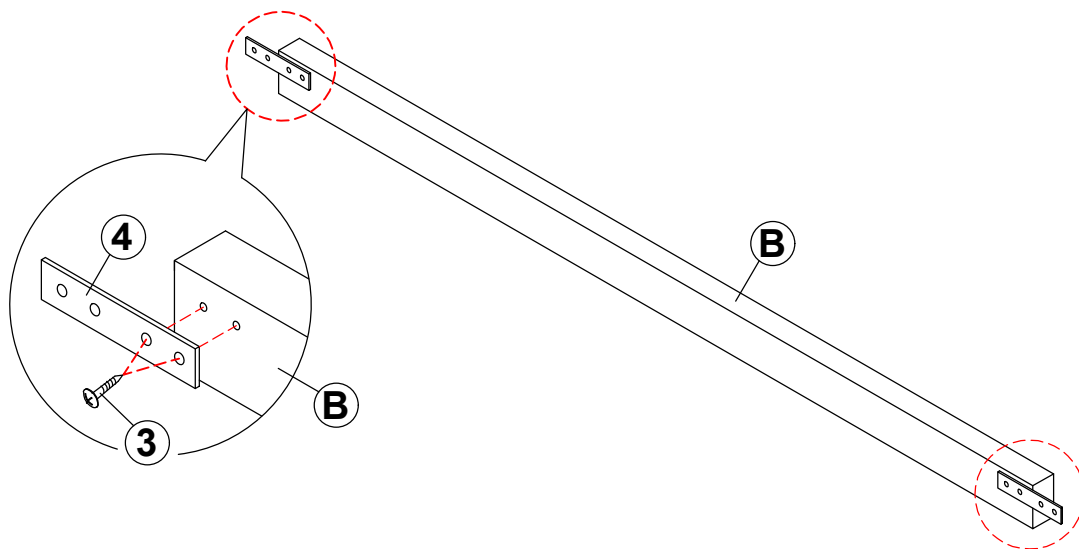

ITEM: **802044**



ASSEMBLY INSTRUCTIONS

STEP 3

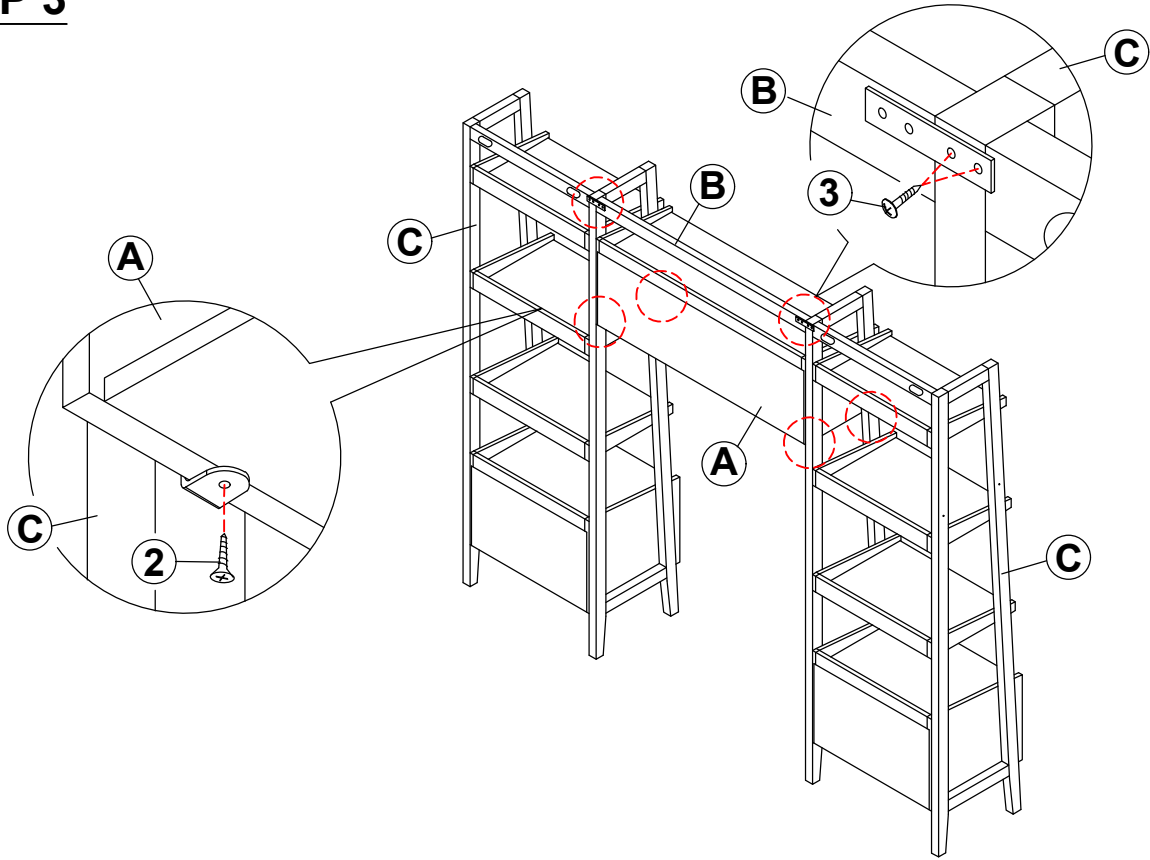

STEP 4

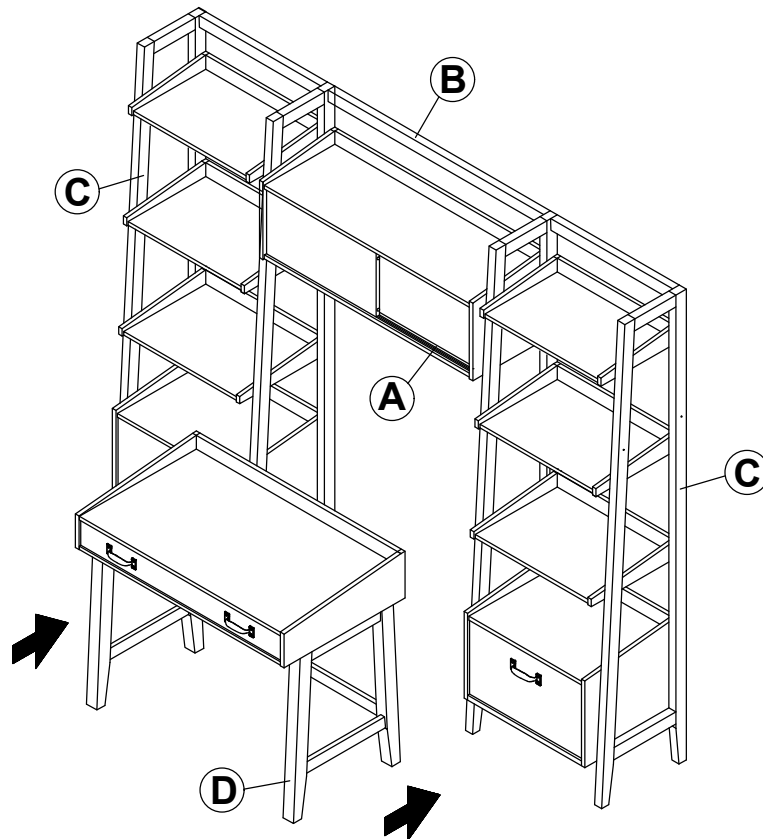

ITEM: **802044**

ASSEMBLY INSTRUCTIONS

STEP 5

COMPLETE

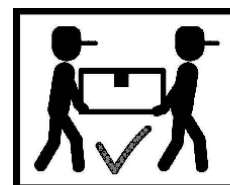
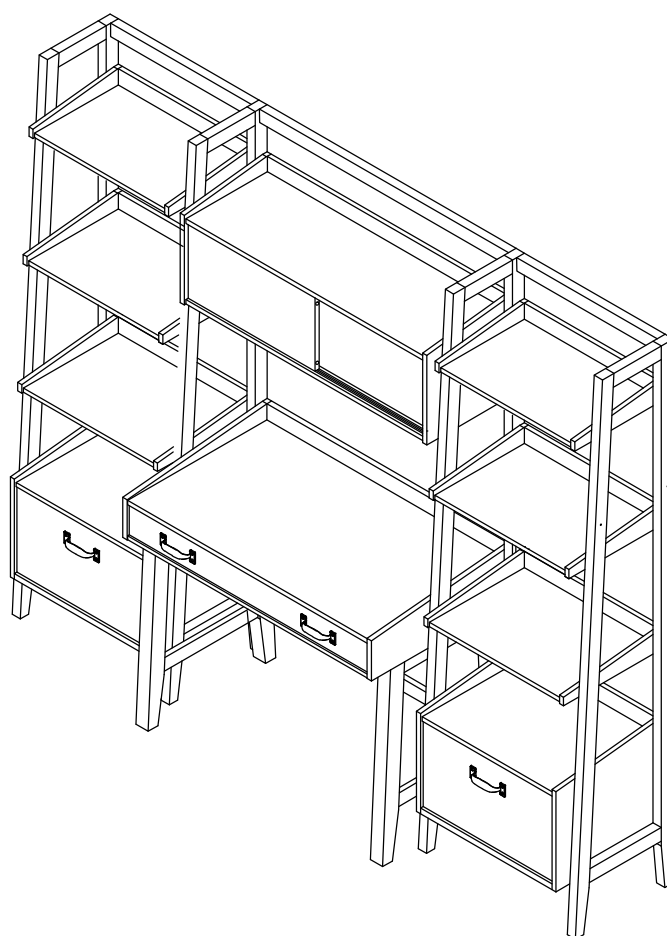

ITEM: **802044**

COASTER
FINE FURNITURE

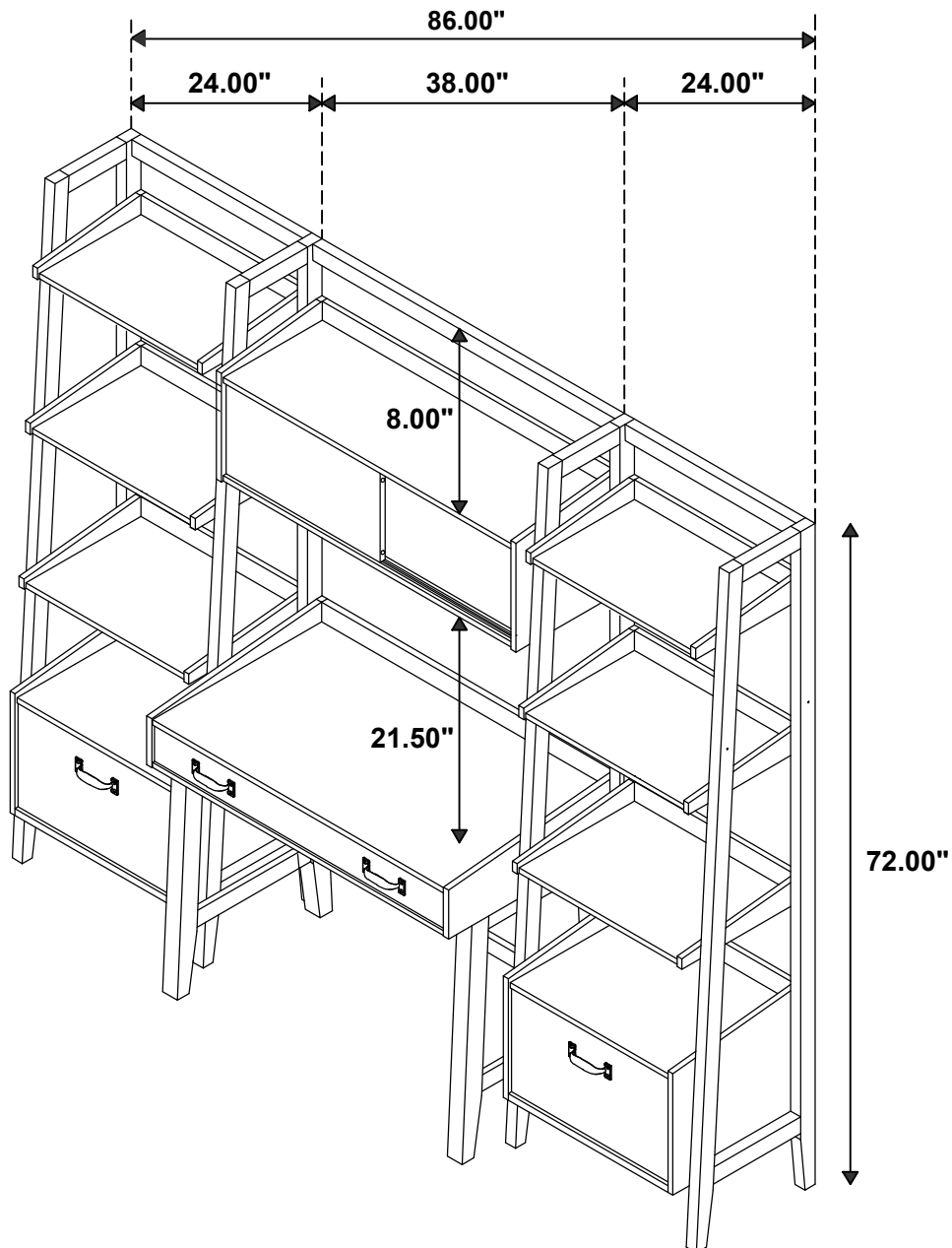

Note : Dimension tolerance $\pm 5\%$