

**ASSEMBLY INSTRUCTIONS**  
**COASTER FINE FURNITURE**



*Fine Furniture for every stage of life*

**801605**  
**Writing Desk**

ITEM: **801605**



## ASSEMBLY INSTRUCTIONS

### ASSEMBLY TIPS:

1. Remove hardware from box and sort by size.
2. Please check to see that all hardware and parts are present prior to start of assembly.
3. Please follow attached instructions in the same sequence as numbered to assure fast & easy assembly.



### WARNING!

1. Don't attempt to repair or modify parts that are broken or defective. Please contact the store immediately.
2. This product is for home use only and not intended for commercial establishments.



ASSEMBLY TIME

30 MINUTES

## PARTS IDENTIFICATION

A TOP

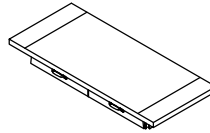

1PC

B LEFT FRONT LEG



1PC

C RIGHT FRONT LEG



1PC

D LEFT BACK LEG



1PC

E RIGHT BACK LEG



1PC

F LEG SUPPORT

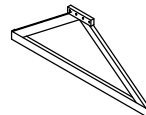

1PC

G LEFT CROSSBAR



1PC

H RIGHT CROSSBAR



1PC

ITEM: **801605**



## ASSEMBLY INSTRUCTIONS

### ASSEMBLY TIPS:





1. Remove hardware from box and sort by size.
2. Please check to see that all hardware and parts are present prior to start of assembly.
3. Please follow attached instructions in the same sequence as numbered to assure fast & easy assembly.



### WARNING!

1. Don't attempt to repair or modify parts that are broken or defective. Please contact the store immediately.
2. This product is for home use only and not intended for commercial establishments.

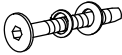
## HARDWARE IDENTIFICATION

|   |  |   |      |
|---|--|---|------|
| 1 | <b>ALLEN WRENCH</b><br>(M4 x 110mm - BLK)          |    | 1PC  |
| 2 | <b>SHORT BOLT WITH WASHER</b><br>(M6 x 40mm - BLK) |    | 2PCS |
| 3 | <b>LONG BOLT WITH WASHER</b><br>(M6 x 50mm - BLK)  |  | 8PCS |
| 4 | <b>WOOD DOWEL</b><br>(M10 x 30mm)                  |  | 8PCS |
| 5 | <b>FLAT HEAD SCREW</b><br>(M4 x 38mm - BLK)        |  | 6PCS |

### NOTE:

Phillips head screw driver is required in the assembly process; however, manufacturer does not provide this item.

ITEM: **801605**



# ASSEMBLY INSTRUCTIONS

## STEP 1

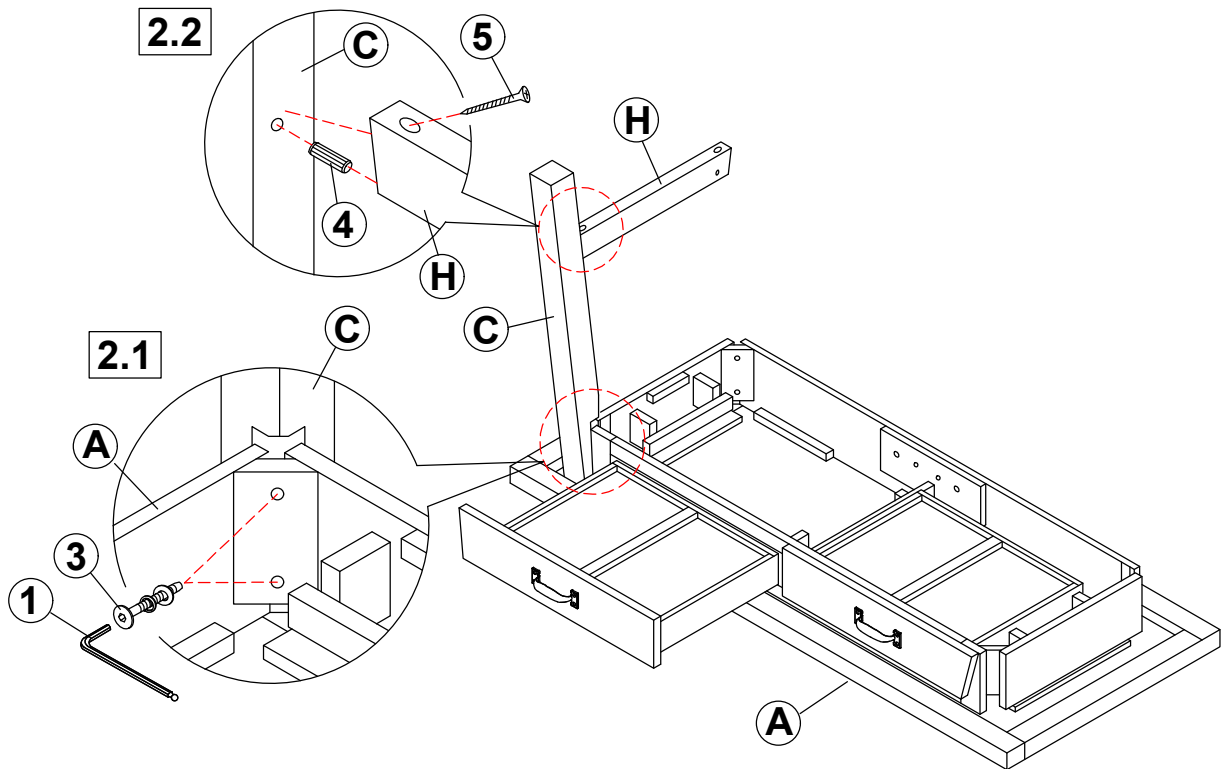

## STEP 2

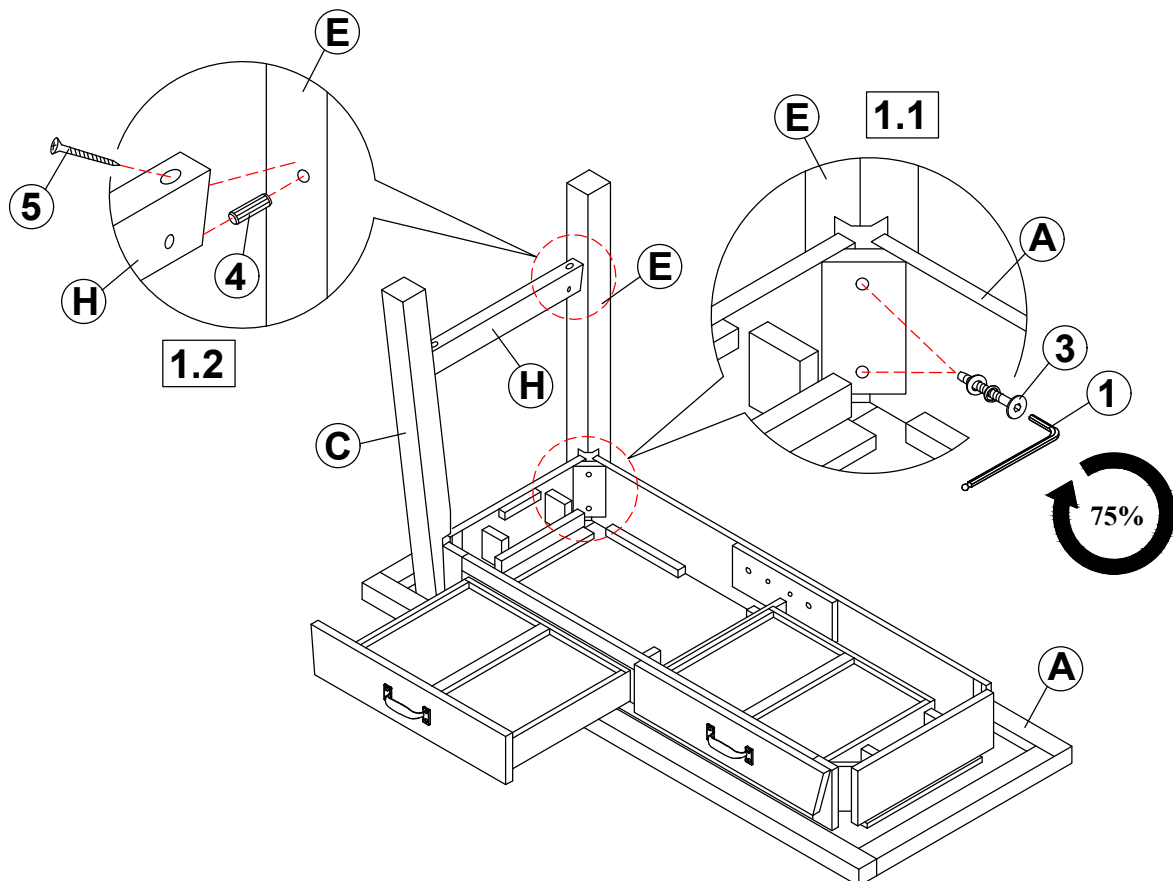

ITEM: **801605**



**ASSEMBLY INSTRUCTIONS**  
**STEP 3**

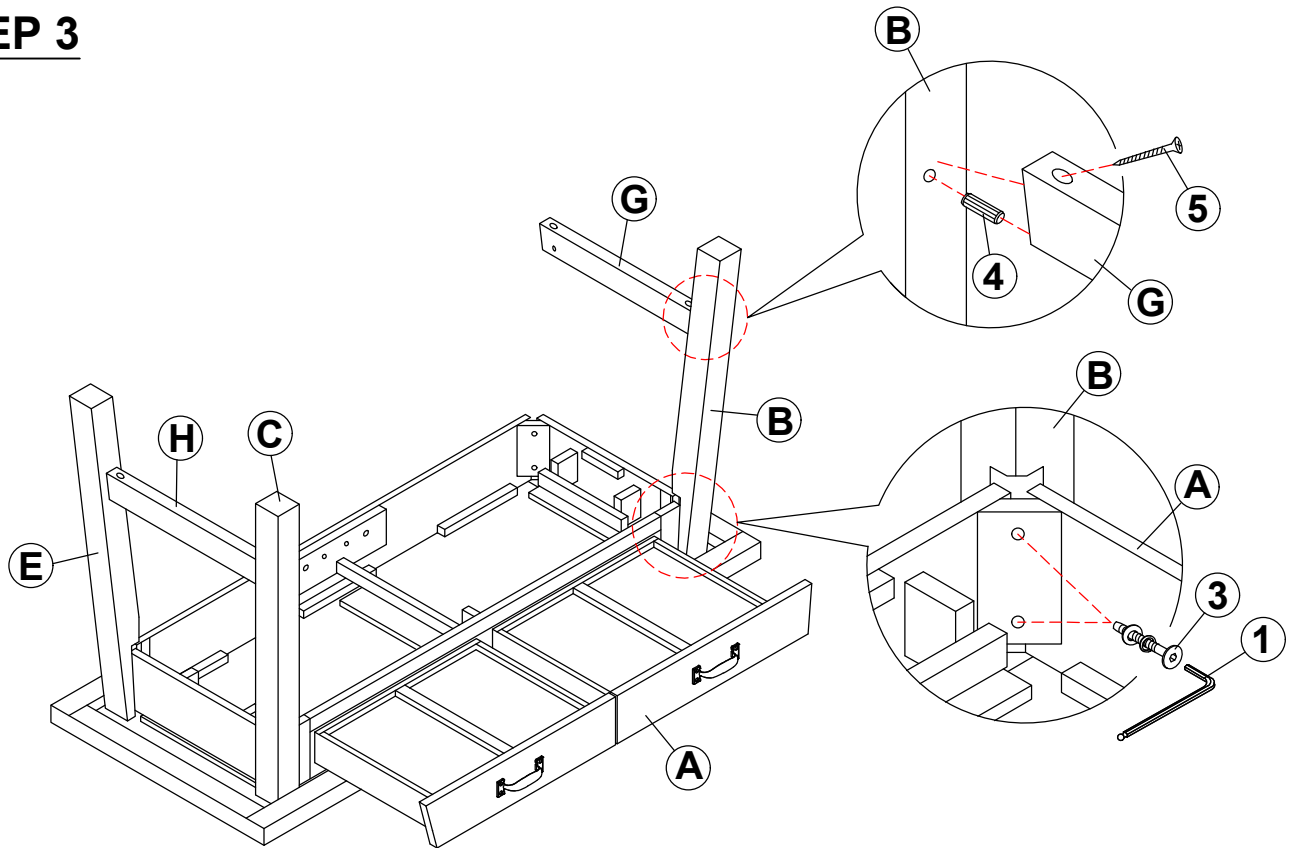

**STEP 4**

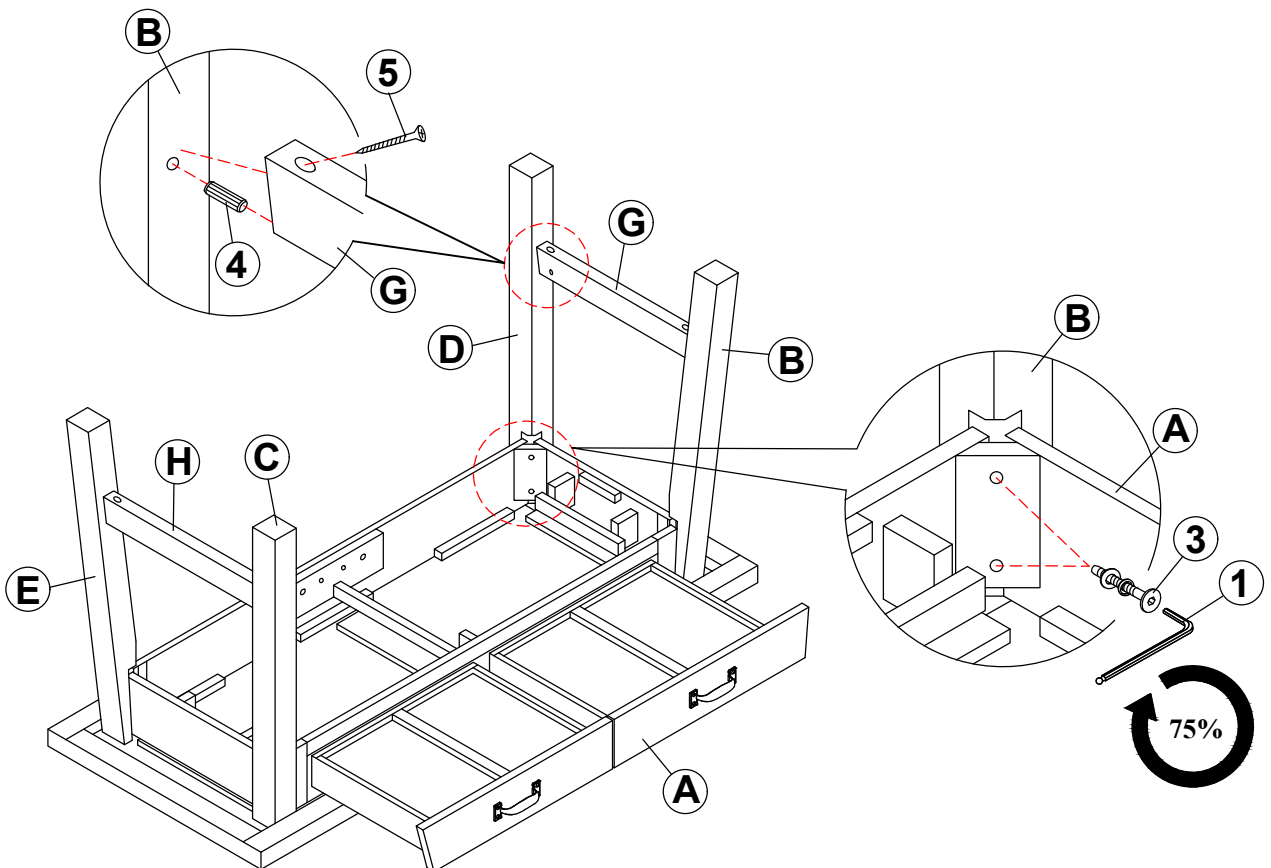

ITEM: **801605**



**ASSEMBLY INSTRUCTIONS**  
**STEP 5**

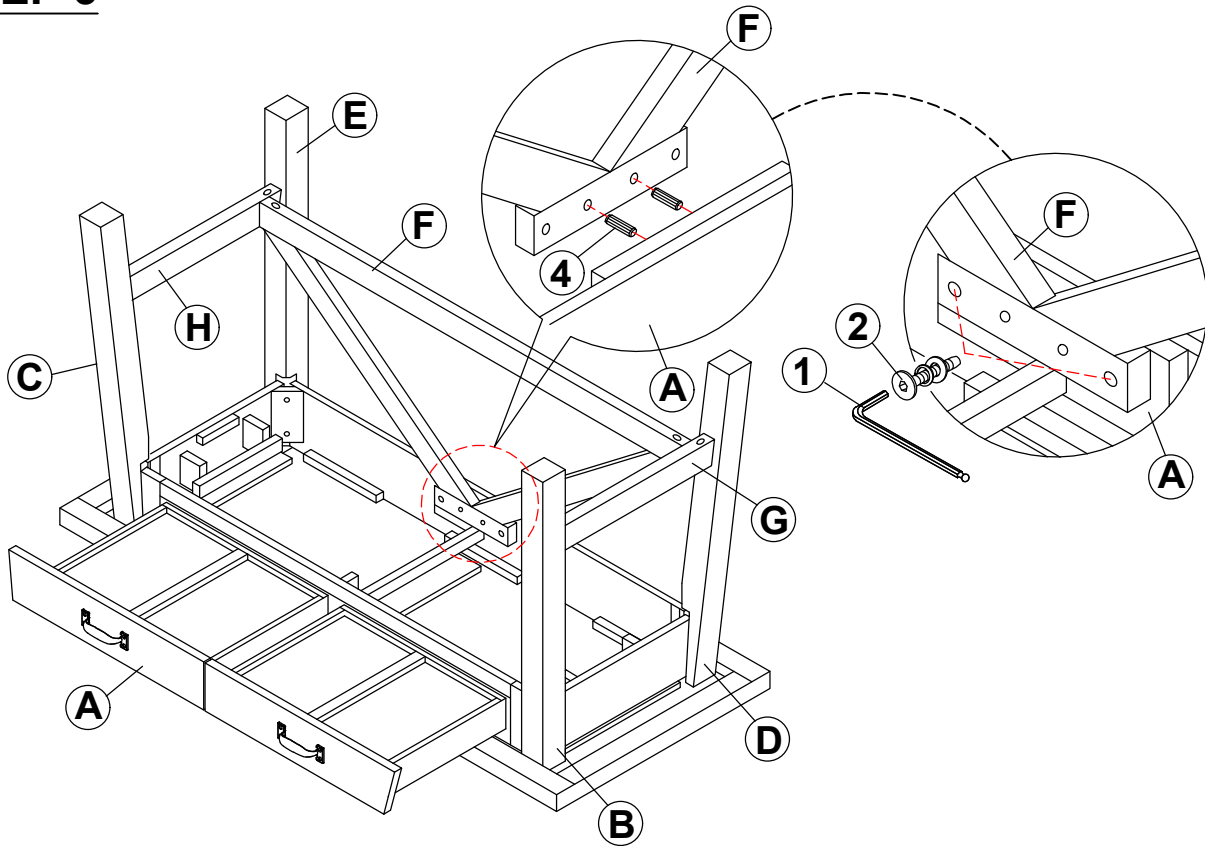

**STEP 6**

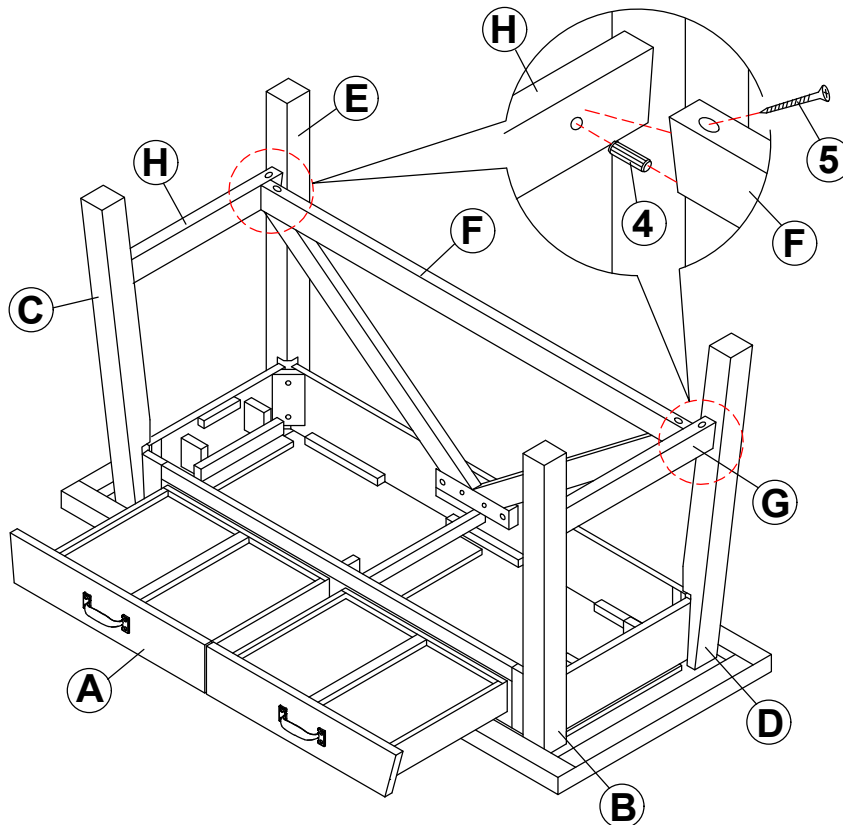

ITEM: **801605**



**ASSEMBLY INSTRUCTIONS**  
**STEP 7**

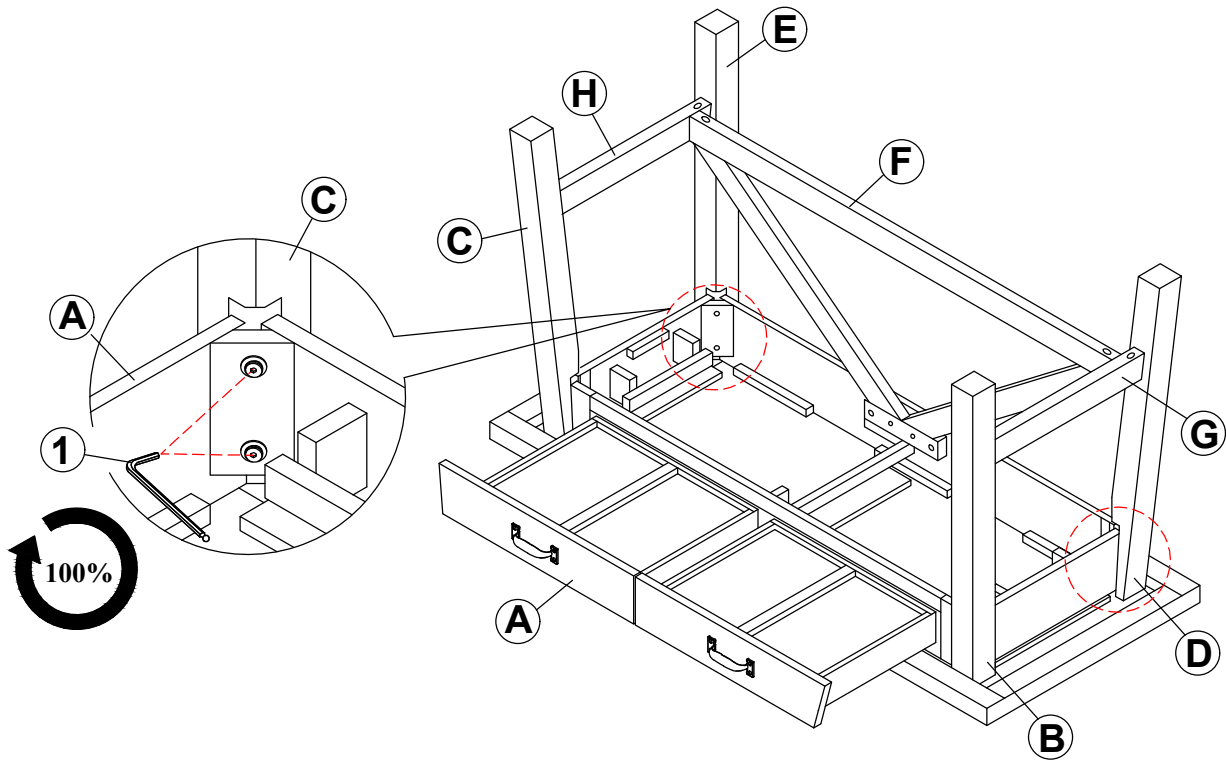

**STEP 8**  
**COMPLETE**

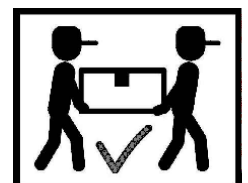
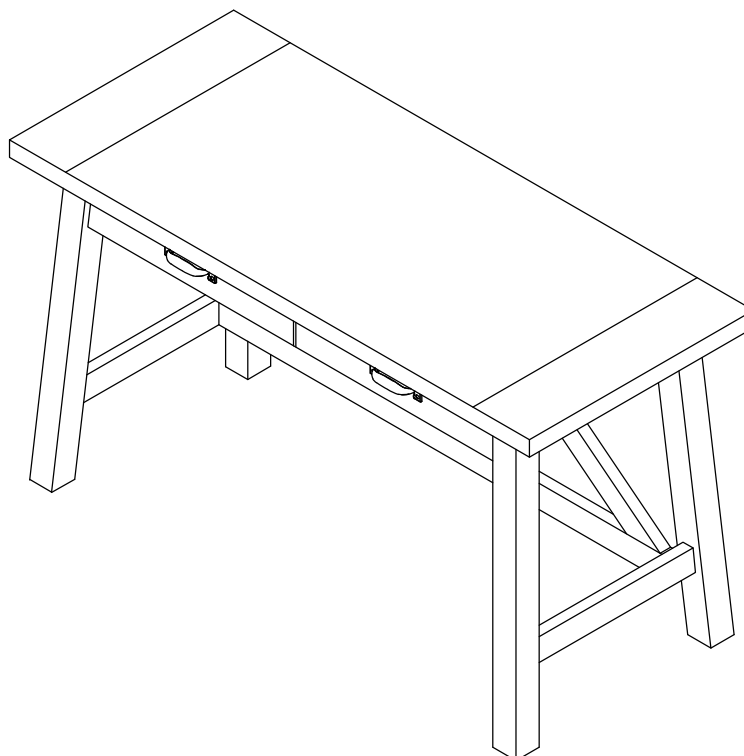

ITEM: **801605**



Inner Size of Drawer : 16.50"W x 12.75"D x 2.00"H x 0.50"T

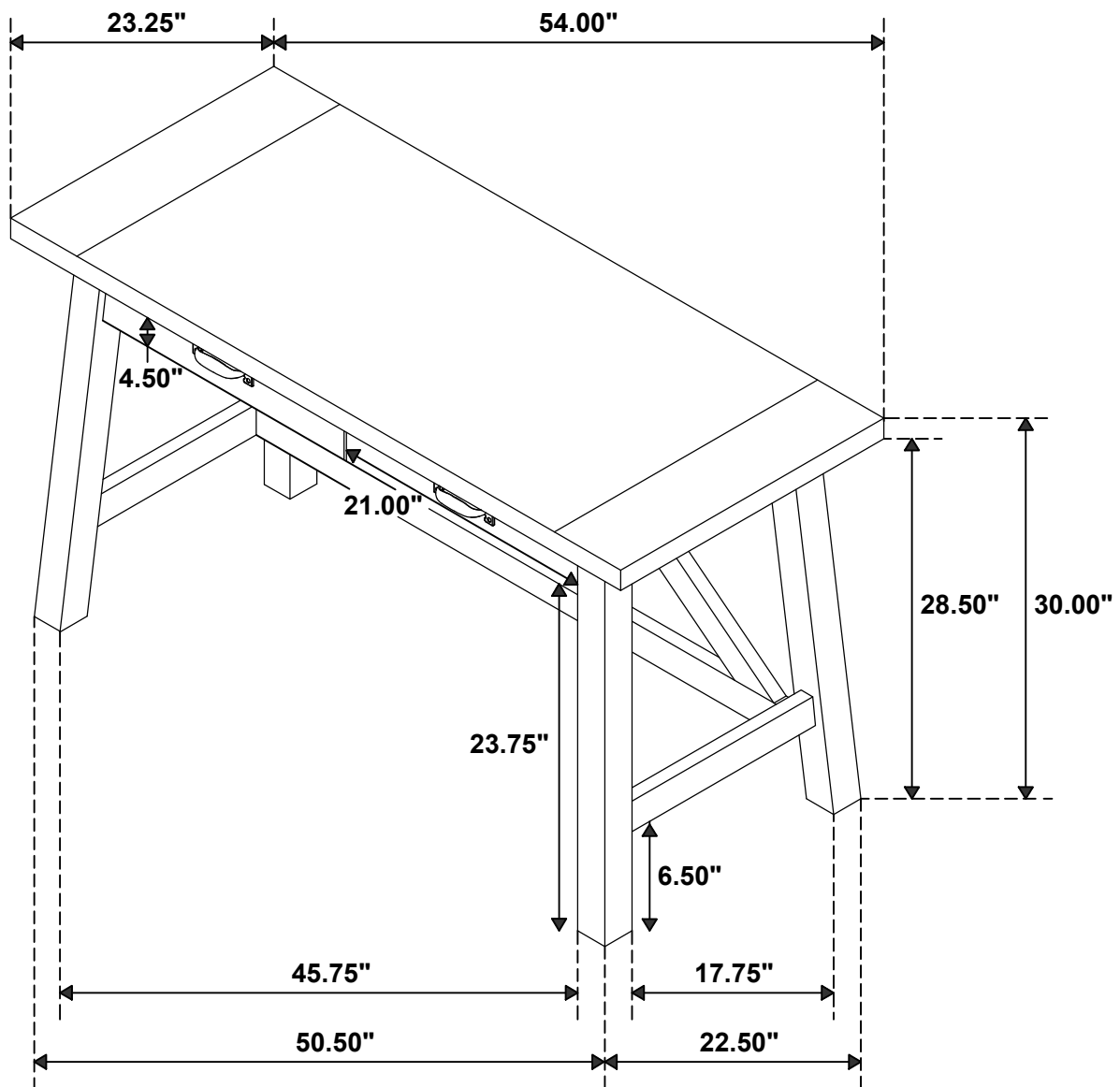

Note : Dimension tolerance  $\pm 5\%$