

*ASSEMBLY INSTRUCTIONS*  
*COASTER FINE FURNITURE*



*Fine Furniture for every stage of life*

**706168**  
**Coffee Table**

ITEM: **706168**



## ASSEMBLY INSTRUCTIONS

### ASSEMBLY TIPS:

1. Remove hardware from box and sort by size.
2. Please check to see that all hardware and parts are present prior to start of assembly.
3. Please follow attached instructions in the same sequence as numbered to assure fast & easy assembly.



### WARNING!

1. Don't attempt to repair or modify parts that are broken or defective. Please contact the store immediately.
2. This product is for home use only and not intended for commercial establishments.



ASSEMBLY TIME

15 MINUTES

## PARTS IDENTIFICATION

A	TOP		1PC
B	LEG		3PCS
C	MOUNTING PLATE		3PCS

## HARDWARE IDENTIFICATION

1	<b>BOLT</b> (M6 X 20mm - BLK)		18PCS
2	<b>FLAT WASHER</b> (M10 X 25mm - BLK)		12PCS
3	<b>ALLEN WRENCH</b> (4mm - BLK)		1PC

ITEM: **706168**

**ASSEMBLY INSTRUCTIONS**

**STEP 1**

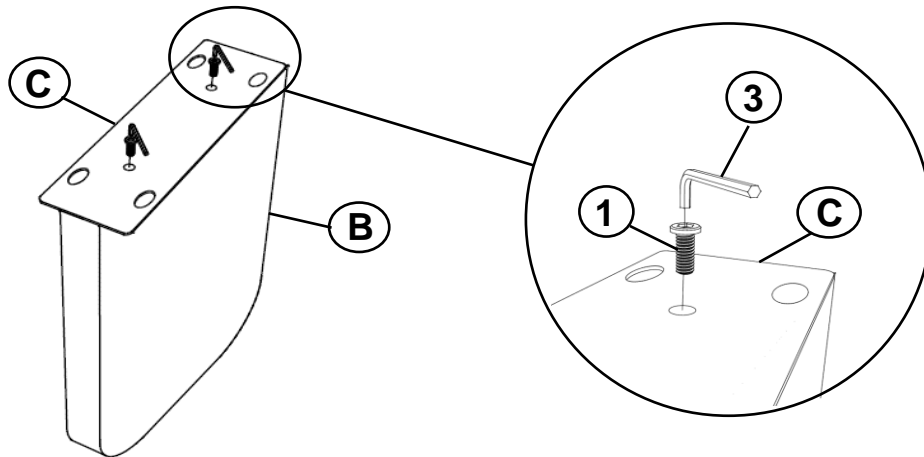

**STEP 2**

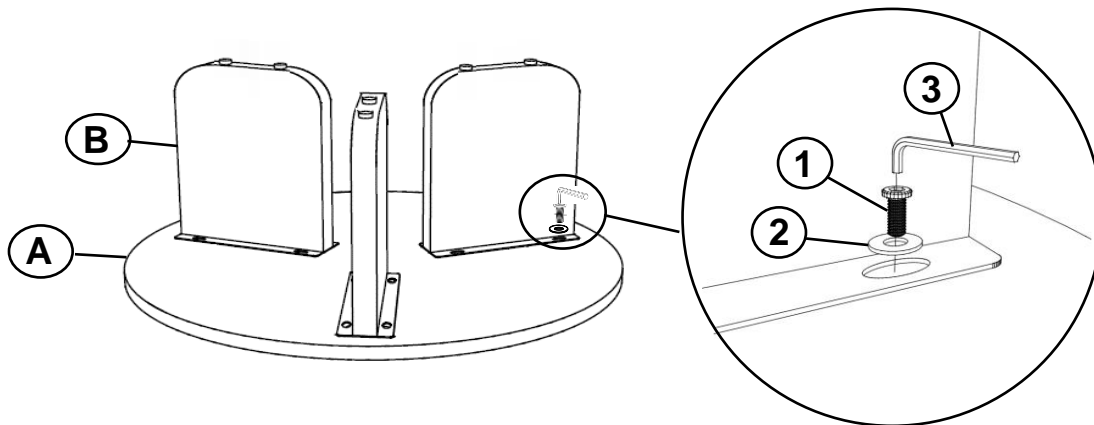

**BOTTOM VIEW**

**STEP 3**  
**COMPLETE**

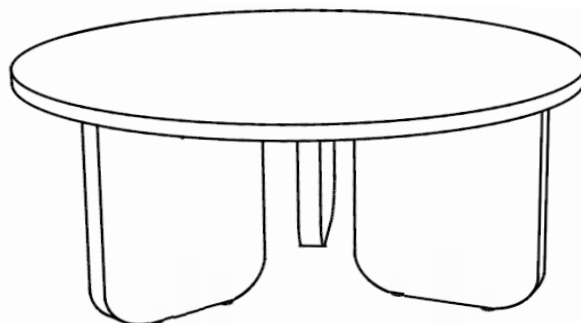

ITEM:706168

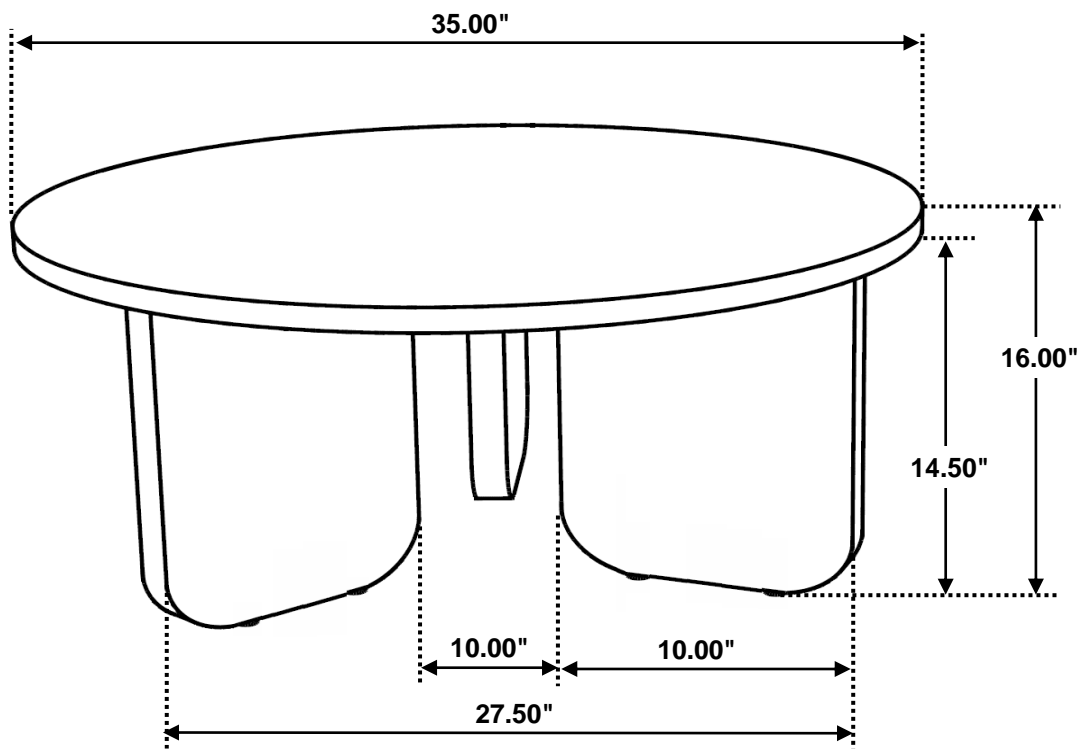

Note : Dimension tolerance  $\pm 5\%$

*ASSEMBLY INSTRUCTIONS*  
*COASTER FINE FURNITURE*



*Fine Furniture for every stage of life*

**706167**  
**End Table**

ITEM: **706167**

## ASSEMBLY INSTRUCTIONS

### ASSEMBLY TIPS:

1. Remove hardware from box and sort by size.
2. Please check to see that all hardware and parts are present prior to start of assembly.
3. Please follow attached instructions in the same sequence as numbered to assure fast & easy assembly.



### WARNING!



1. Don't attempt to repair or modify parts that are broken or defective. Please contact the store immediately.
2. This product is for home use only and not intended for commercial establishments.



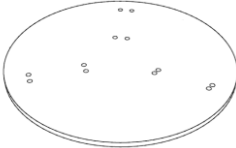
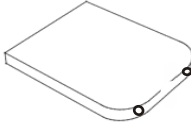

ASSEMBLY TIME

15 MINUTES

## PARTS IDENTIFICATION

A	TOP		1PC
B	LEG		3PCS
C	MOUNTING PLATE		3PCS

## HARDWARE IDENTIFICATION

1	<b>BOLT</b> (M6 X 20mm - BLK)		18PCS
2	<b>FLAT WASHER</b> (M10 X 25mm - BLK)		12PCS
3	<b>ALLEN WRENCH</b> (4mm - BLK)		1PC

ITEM: **706167**

**ASSEMBLY INSTRUCTIONS**



**STEP 1**

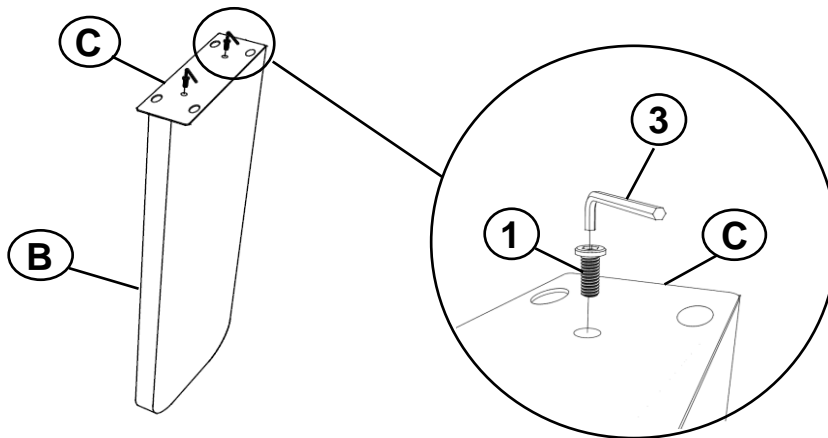

**STEP 2**

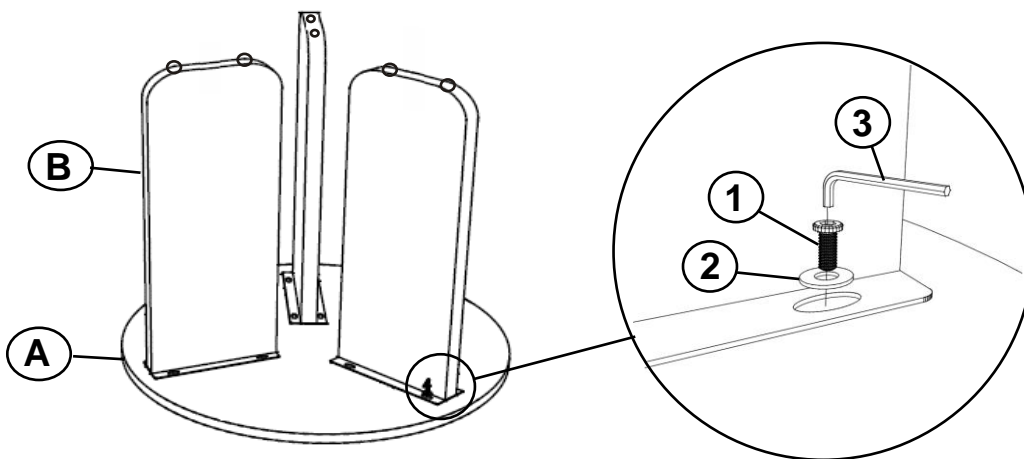

**BOTTOM VIEW**

**STEP 3**  
**COMPLETE**

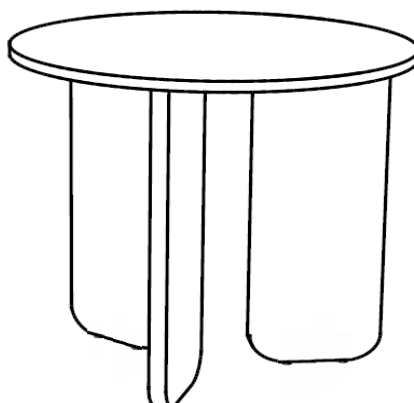

ITEM:706167

**COASTER**  
FINE FURNITURE

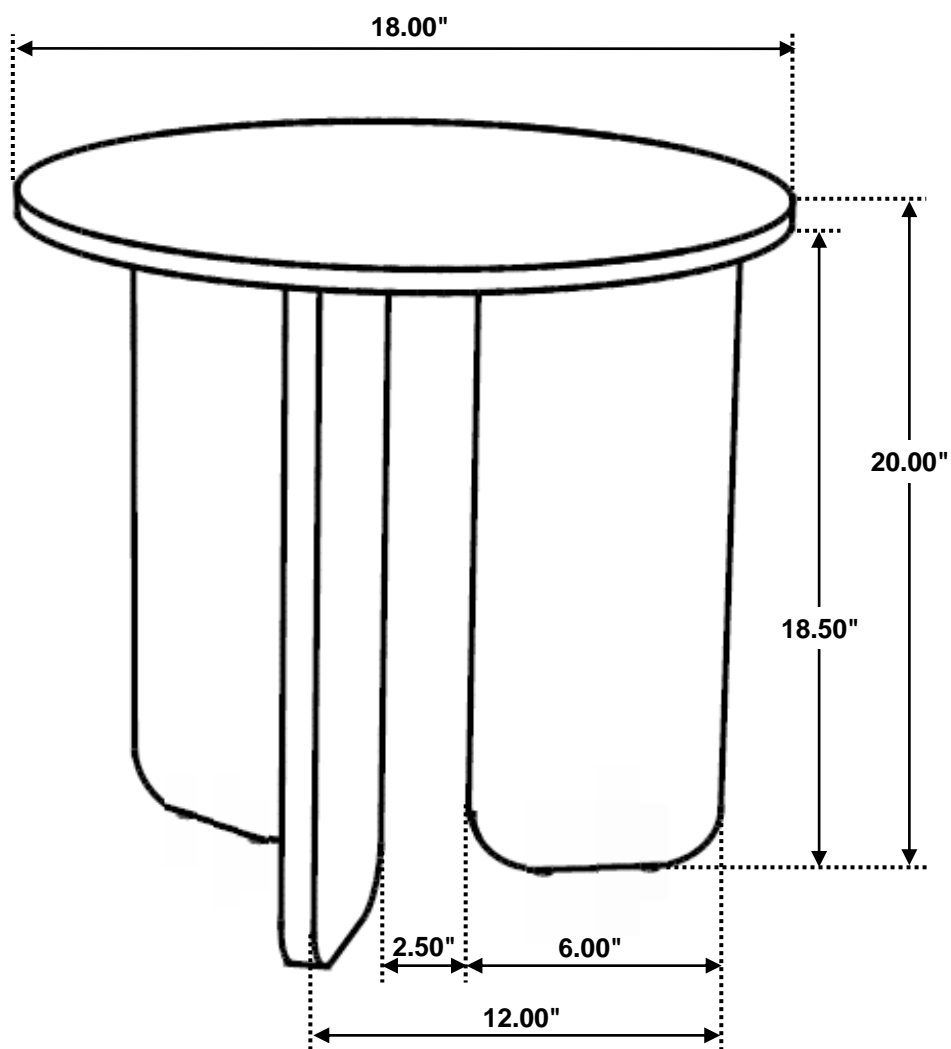

Note : Dimension tolerance  $\pm 5\%$