

ASSEMBLY INSTRUCTIONS
COASTER FINE FURNITURE



Fine Furniture for every stage of life

222801KW(B1-B3)
California King Bed

ITEM: 222801KW(B1-B3)



ASSEMBLY INSTRUCTIONS

ASSEMBLY TIPS:

1. Remove hardware from box and sort by size.
2. Please check to see that all hardware and parts are present prior to start of assembly.
3. Please follow attached instructions in the same sequence as numbered to assure fast & easy assembly.



WARNING!

1. Don't attempt to repair or modify parts that are broken or defective. Please contact the store immediately.
2. This product is for home use only and not intended for commercial establishments.

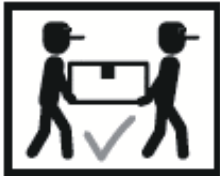

ASSEMBLY TIME

30 MINUTES

PART IDENTIFICATION

B1 (BOX 1)

A	HEADBOARD PANEL		1PC
B	LEFT HEADBOARD LEG		1PC
C	RIGHT HEADBOARD LEG		1PC
D	HEADBOARD BOTTOM RAIL		1PC
E	CONCEAL PANEL		4PCS

B2 (BOX 2)

F	FOOTBOARD		1PC
---	-----------	--	-----

B3 (BOX 3)

G	LEFT BED RAIL		1PC
H	RIGHT BED RAIL		1PC
I	ROLL SLAT (10 PCS)		1SET
J	CENTER RAIL		1PC
K	CENTER RAIL SUPPORT WITH LEVELER		3PCS
HB	222801KW(B1) FROM BOX 1 HEADBOARD COMPLETE		1PC
F	222801KW(B2) FROM BOX 2 FOOTBOARD		1PC

ITEM: 222801KW(B1-B3)

ASSEMBLY INSTRUCTIONS

ASSEMBLY TIPS:

1. Remove hardware from box and sort by size.
2. Please check to see that all hardware and parts are present prior to start of assembly.
3. Please follow attached instructions in the same sequence as numbered to assure fast & easy assembly.







WARNING!



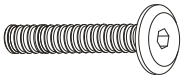



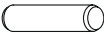

1. Don't attempt to repair or modify parts that are broken or defective. Please contact the store immediately.
2. This product is for home use only and not intended for commercial establishments.

HARDWARE IDENTIFICATION

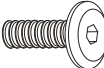
Z-B1 (BOX 1) - HARDWARE PACK IS LOCATED IN 222801KW(B1)

1	LONG BOLT (5/16" x 50mm - BLK)		8PCS
2	LOCK WASHER (1.6 x 14mm - BLK)		8PCS
3	FLAT WASHER (2 x 19mm - BLK)		8PCS
4	ALLEN WRENCH (M5 x 75mm - BLK)		1PC
5	WOOD DOWEL (10 x 40mm - BRW)		8PCS

Z-B3 (BOX 3) - HARDWARE PACK IS LOCATED IN 222801KW(B3)

2	LOCK WASHER (1.6 x 14mm - BLK)		4PCS
3	FLAT WASHER (2 x 19mm - BLK)		4PCS
6	SHORT BOLT (5/16" x 19mm - BLK)		4PCS
7	FLAT HEAD SCREW (8 x 32mm - BLK)		8PCS
8	THREADED BOLT (5/16" x 80mm - WHT)		8PCS
9	HEX NUT (5/16" x 13mm - WHT)		8PCS
10	HALF ROUND NUT (22 x 17 x 10mm - WHT)		8PCS
11	WRENCH (13mm - WHT)		1PC

NOTE :

Philips head screw driver is required in the assembly process; however, manufacturer does not provide this item.

ITEM: 222801KW(B1-B3)

ASSEMBLY INSTRUCTIONS

STEP 1

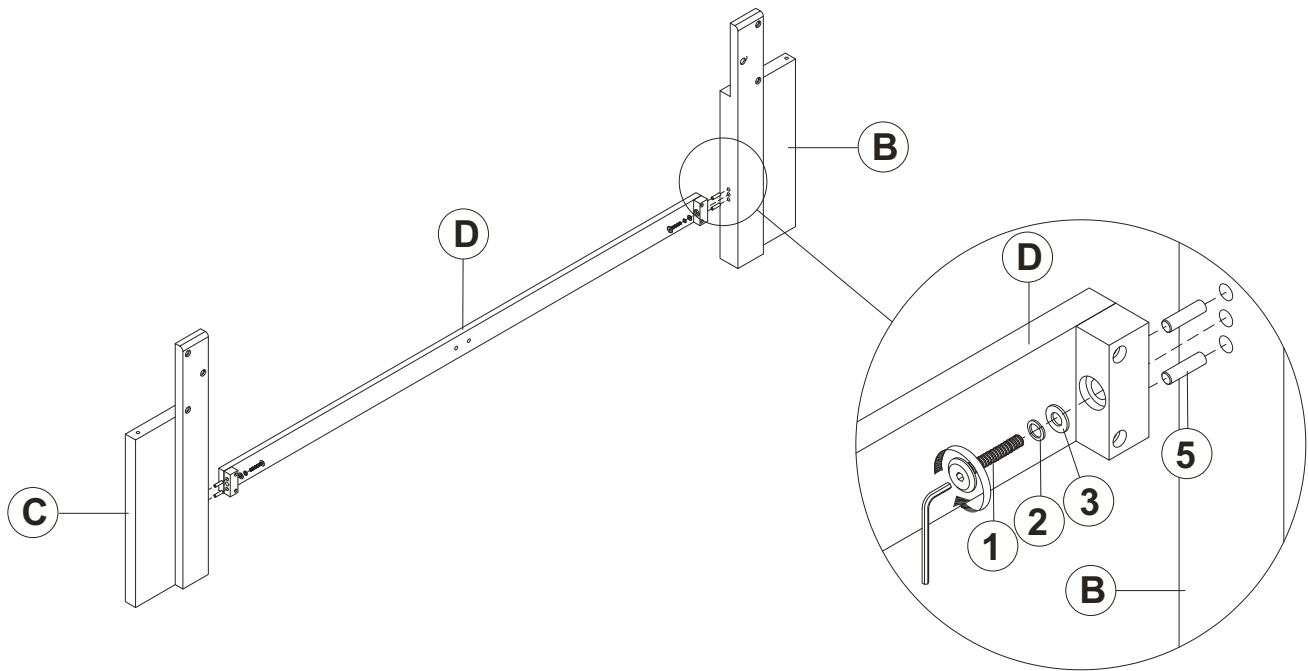

STEP 2

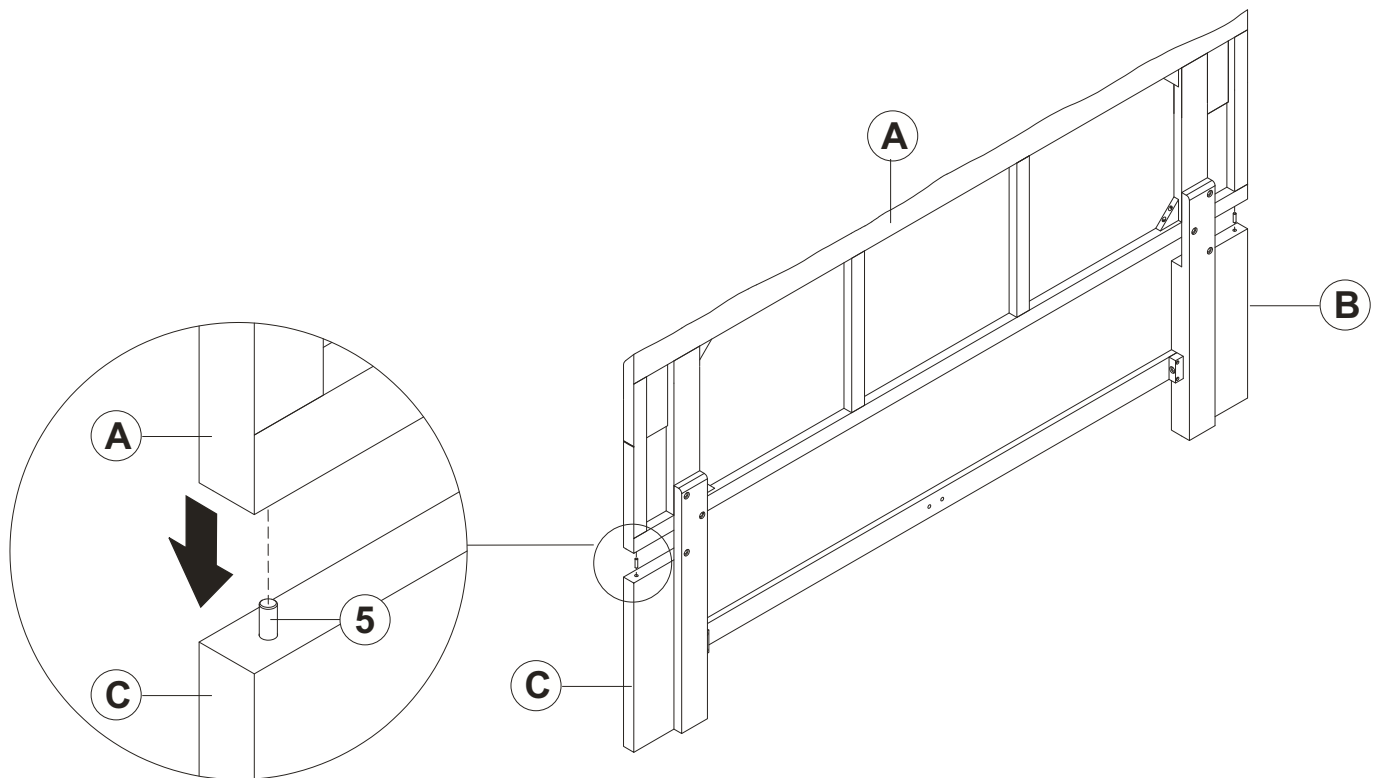

ITEM: 222801KW(B1-B3)

ASSEMBLY INSTRUCTIONS

STEP 3

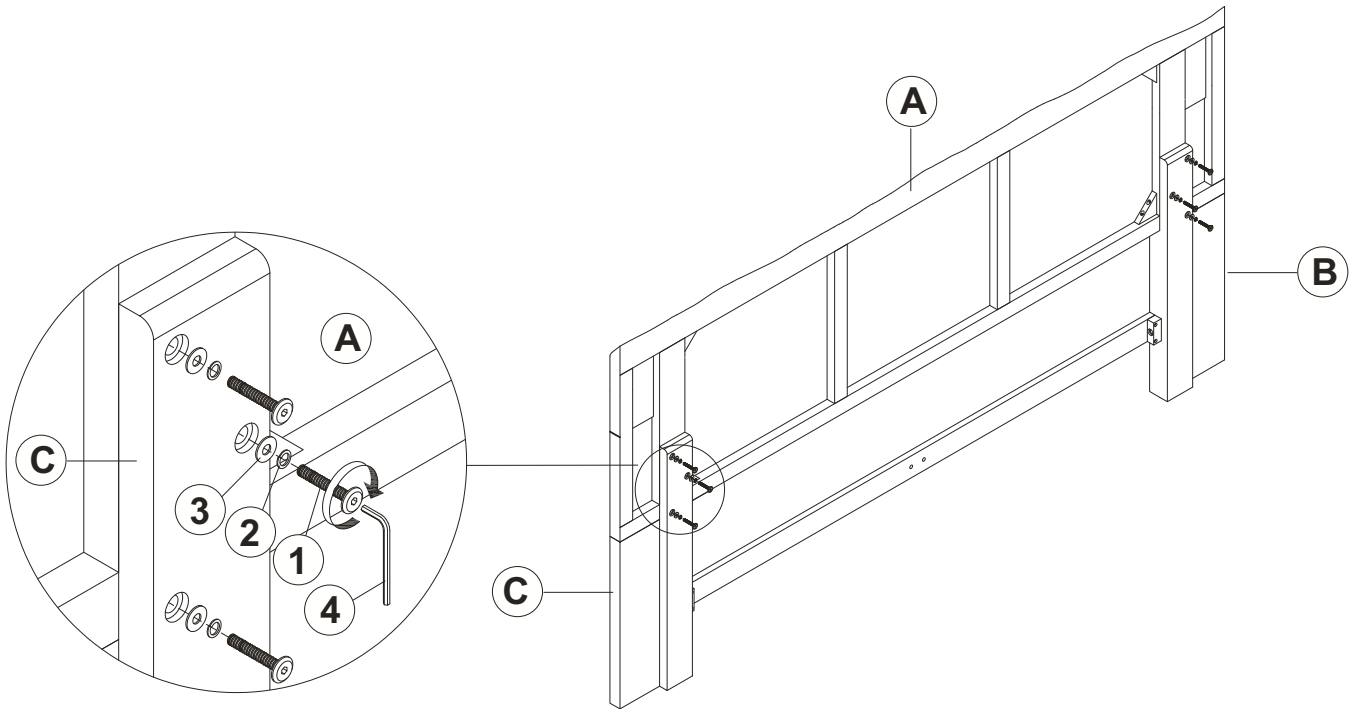

STEP 4

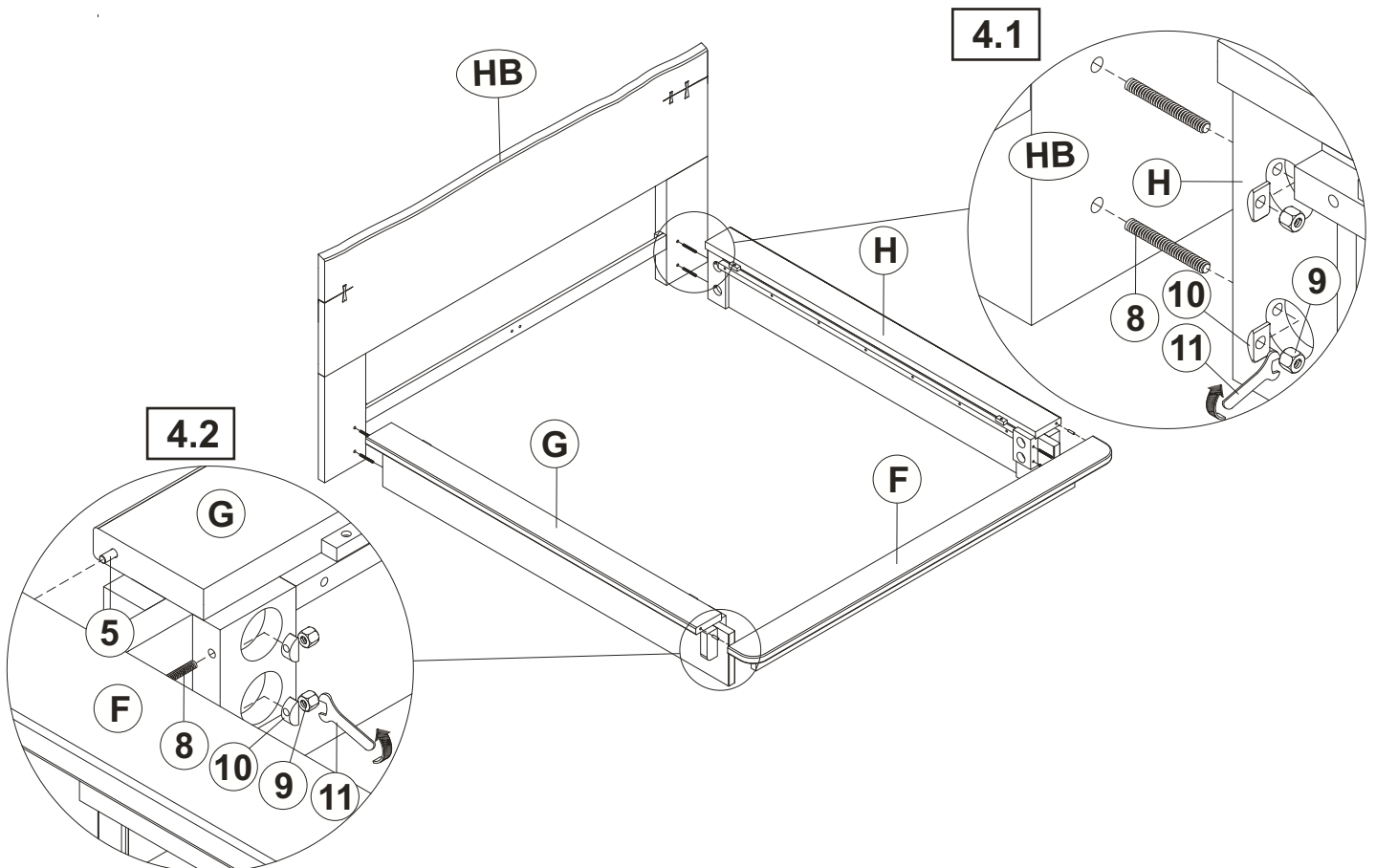

ITEM: 222801KW(B1-B3)

ASSEMBLY INSTRUCTIONS

STEP 5

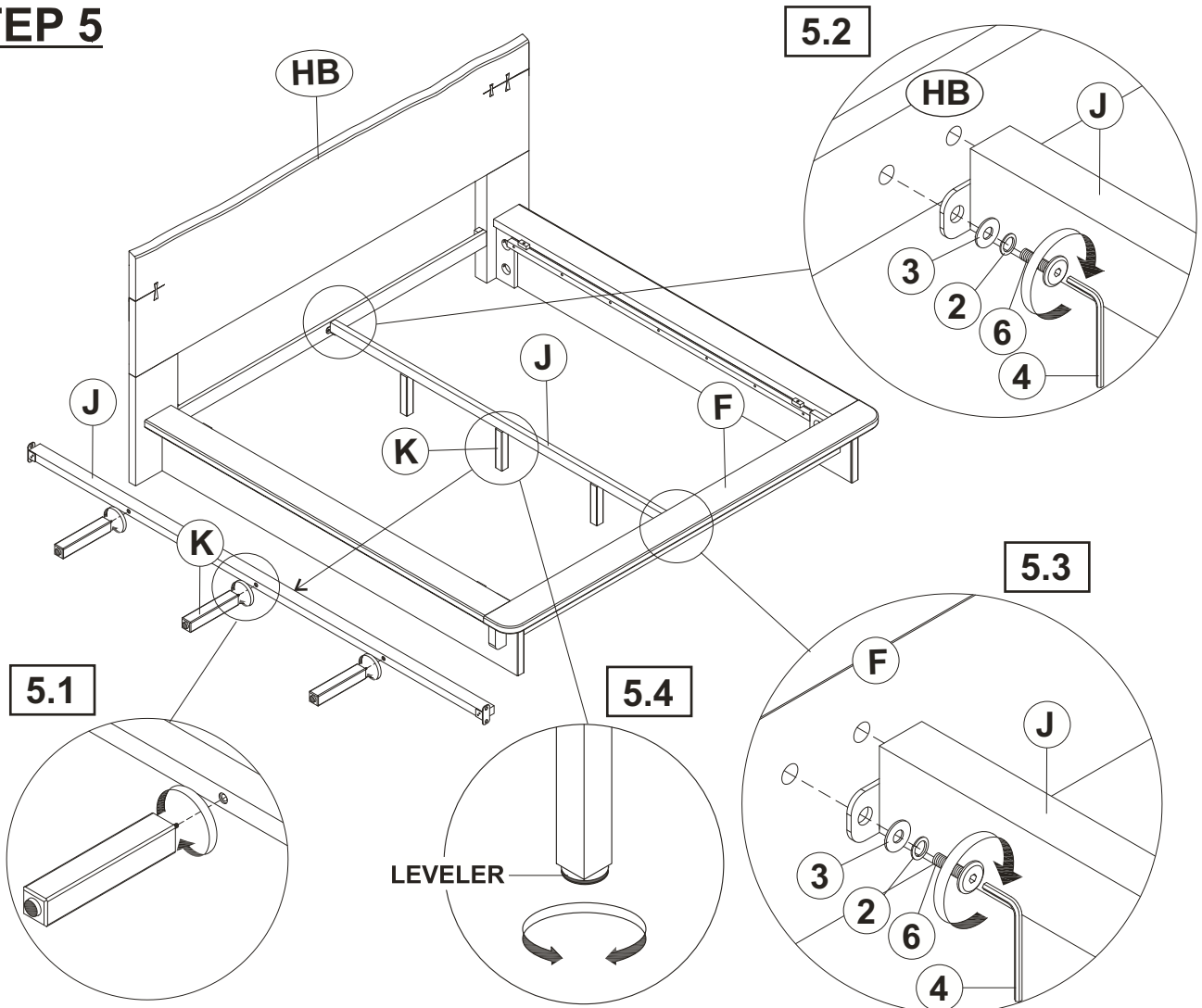

STEP 6

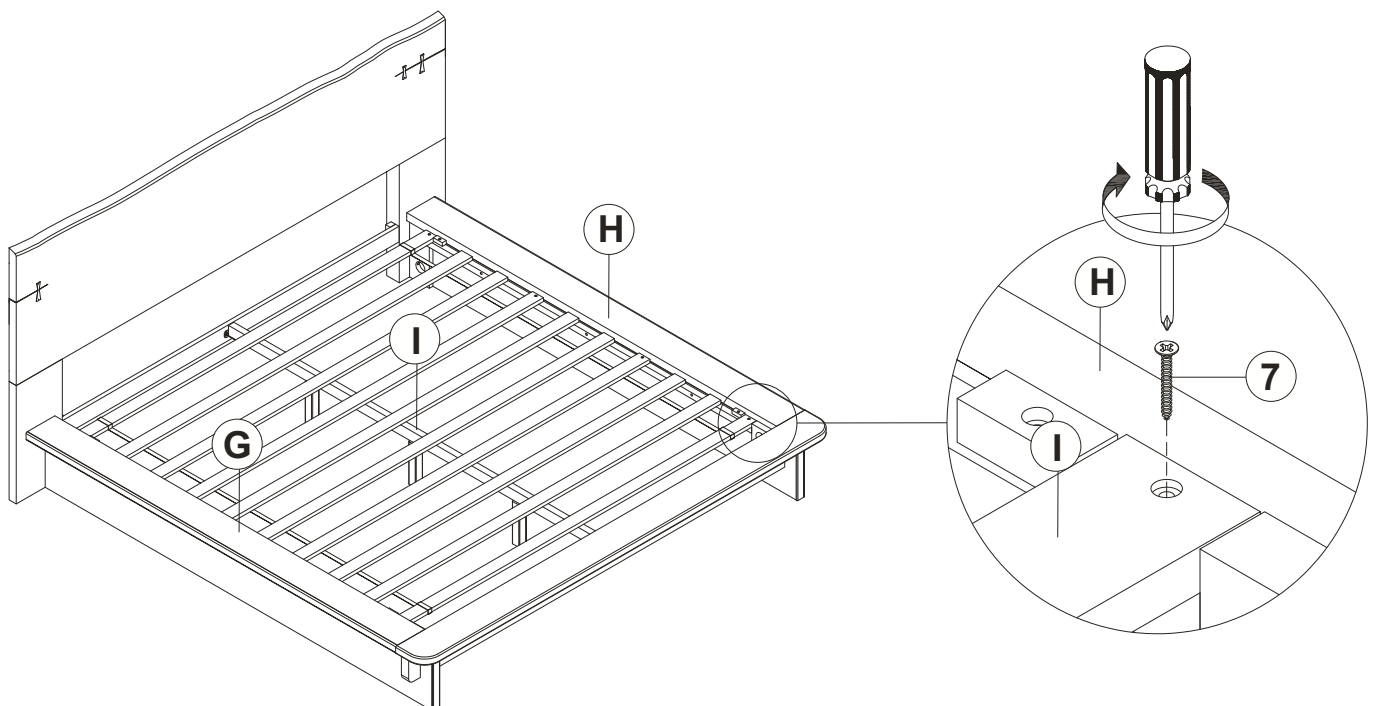

ITEM: **222801KW(B1-B3)**

ASSEMBLY INSTRUCTIONS



STEP 7

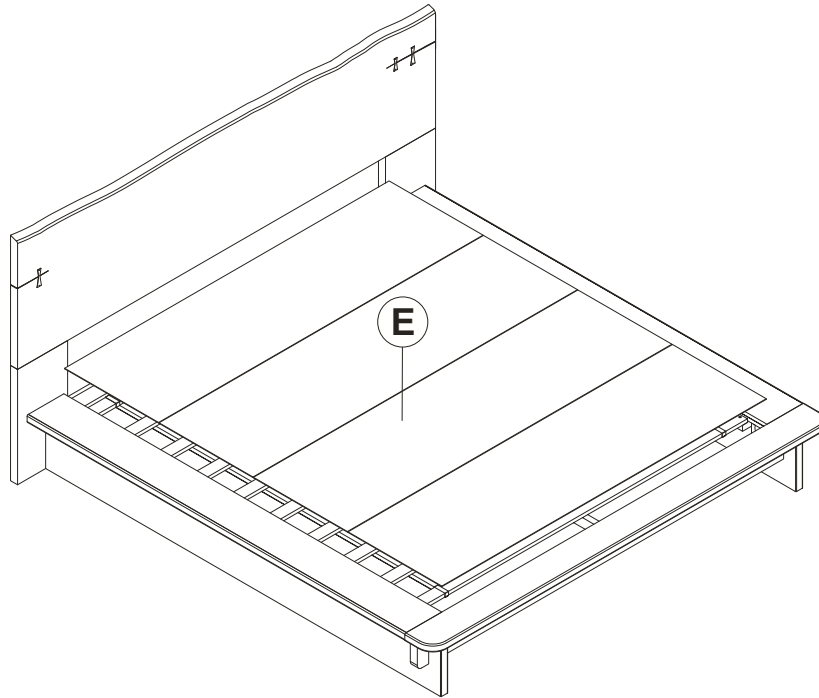

STEP 8
COMPLETE

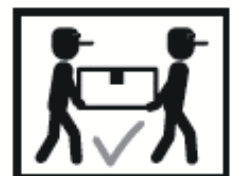
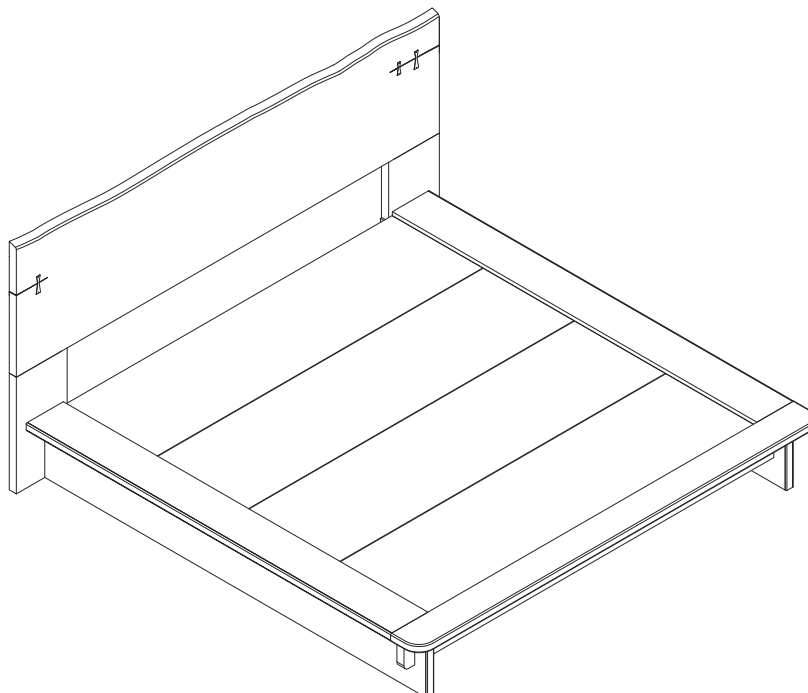

ITEM: 222801KW(B1-B3)



Inner Size : 73.00"W x 85.00"D

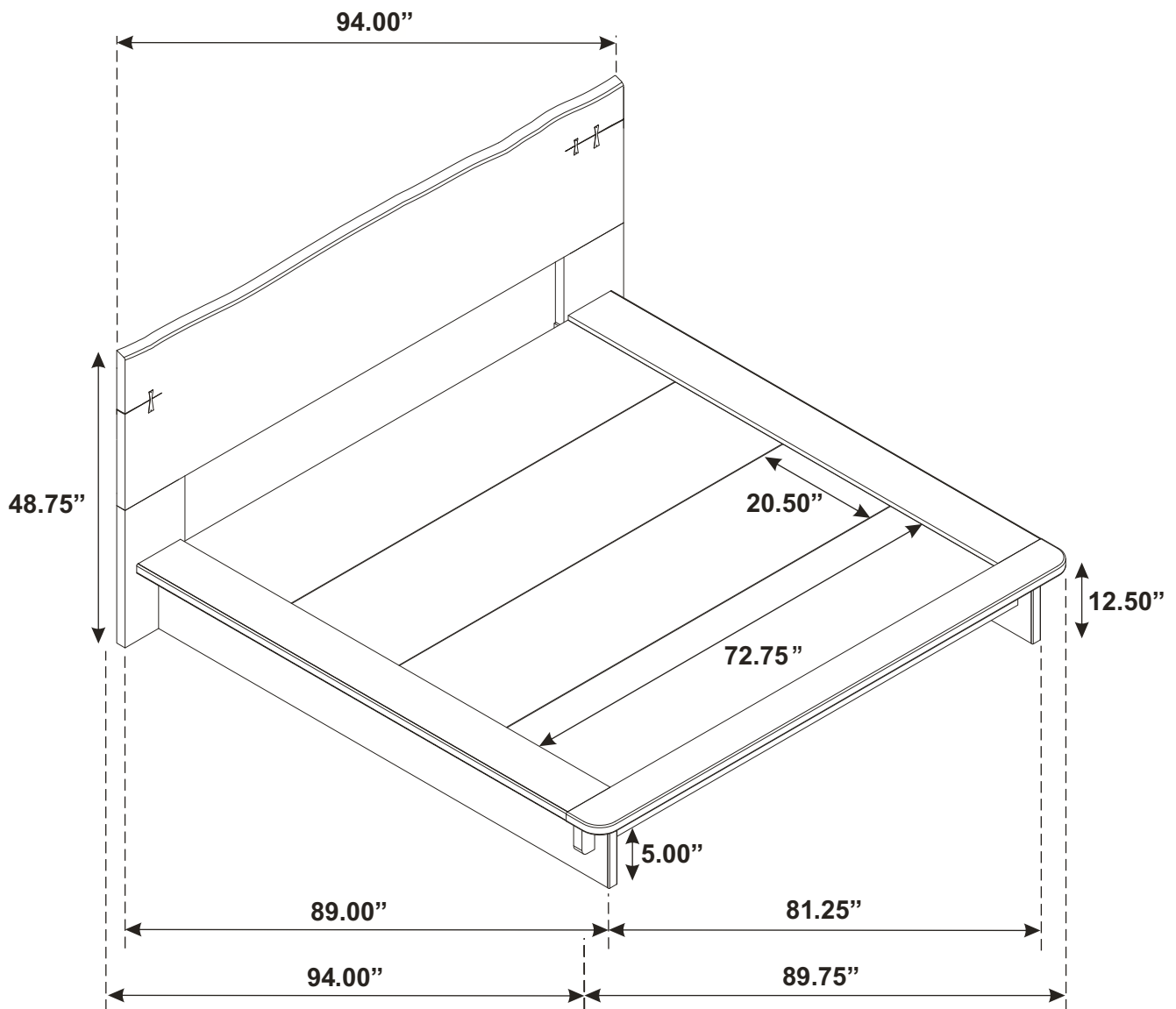

Note: Dimension tolerance $\pm 5\%$