

ASSEMBLY INSTRUCTIONS
COASTER FINE FURNITURE

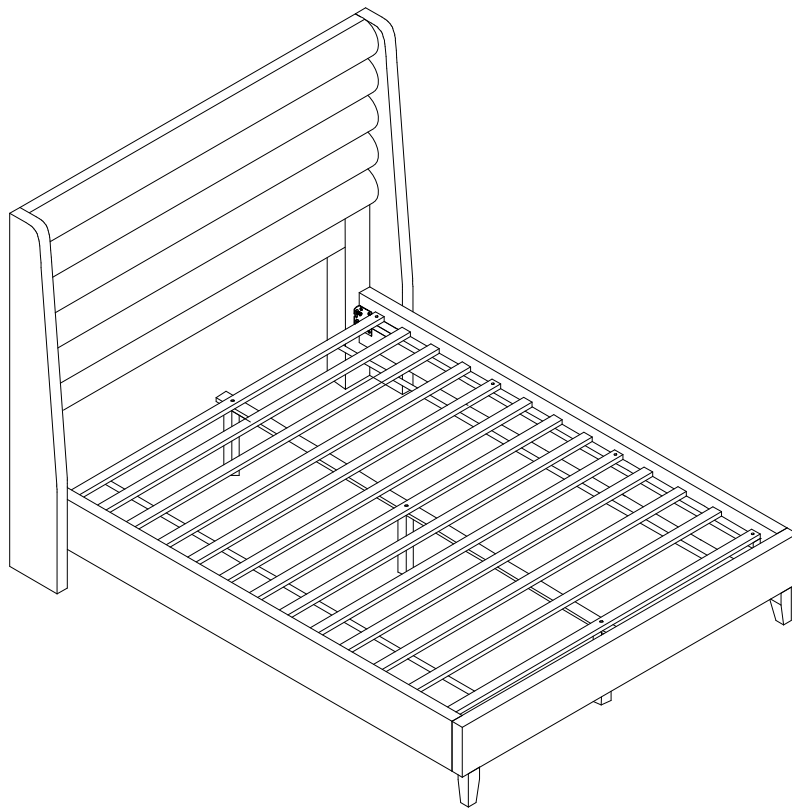

Fine Furniture for every stage of life

315983Q(B1&B2)
Queen Bed

ITEM: 315983Q(B1&B2)

ASSEMBLY INSTRUCTIONS

ASSEMBLY TIPS:

1. Remove hardware from box and sort by size.
2. Please check to see that all hardware and parts are present prior to start of assembly.
3. Please follow attached instructions in the same sequence as numbered to assure fast & easy assembly.



WARNING!

1. Don't attempt to repair or modify parts that are broken or defective. Please contact the store immediately.
2. This product is for home use only and not intended for commercial establishments.

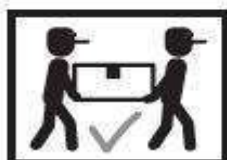







ASSEMBLY TIME

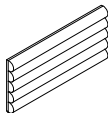

30 MINUTES

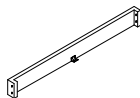
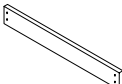
PARTS IDENTIFICATION

B1 (BOX 1)

A	HEADBOARD PANEL		1PC	B	LEFT HEADBOARD SIDE RAIL		1PC
C	LEFT HEADBOARD LEG		1PC	D	RIGHT HEADBOARD SIDE RAIL		1PC
E	RIGHT HEADBOARD LEG		1PC	F	HEADBOARD SUPPORT BAR		1PC
H	FOOTBOARD PANEL		1PC	G	FOOTBOARD LEG		2PCS

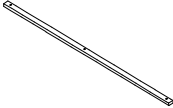
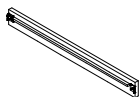
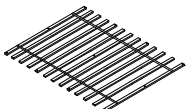
B2 (BOX 2)

I	CENTER RAIL		1PC	J	BED RAIL		2PCS
K	ROLL SLAT (13PCS)		1SET	L	CENTER RAIL SUPPORT WITH LEVELER		3PCS

ITEM: 315983Q(B1&B2)

ASSEMBLY INSTRUCTIONS

ASSEMBLY TIPS:

1. Remove hardware from box and sort by size.
2. Please check to see that all hardware and parts are present prior to start of assembly.
3. Please follow attached instructions in the same sequence as numbered to assure fast & easy assembly.









WARNING!





1. Don't attempt to repair or modify parts that are broken or defective. Please contact the store immediately.
2. This product is for home use only and not intended for commercial establishments.

HARDWARE IDENTIFICATION

Z-B1 (BOX 1) - HARDWARE PACK IS LOCATED IN 315983Q(B1)

1	LONG THREADED BOLT (Ø5/16" x 110mm - RBW)		4PCS	2	SHORT THREADED BOLT (Ø5/16" x 50mm - RBW)		12PCS
3	BIG FLAT WASHER (Ø5/16"x 22mm - RBW)		14PCS	4	LOCK WASHER (Ø5/16" - RBW)		16PCS
5	ALLEN WRENCH (5mm x 100mm - RBW)		1PC	6	FLAT HEAD SCREW (M4 x 20mm - BLK)		2PCS
7	SMALL FLAT WASHER (Ø5/16"x 19mm - RBW)		2PCS				

Z-B2 (BOX 2) - HARDWARE PACK IS LOCATED IN 315983Q(B2)

8	THREADED BOLT (Ø5/16" x 35mm - RBW)		8PCS	9	FLAT WASHER (Ø5/16"x 19mm - RBW)		8PCS
10	FLAT HEAD SCREW (M4 x 35mm - RBW)		8PCS	11	LOCK WASHER (Ø5/16" - RBW)		8PCS
12	ALLEN WRENCH (5mm x 100mm - RBW)		1PC				

NOTE:

Phillips head screw driver is required in the assembly process; however, manufacturer does not provide this item.

ITEM: 315983Q(B1&B2)

ASSEMBLY INSTRUCTIONS

STEP 1

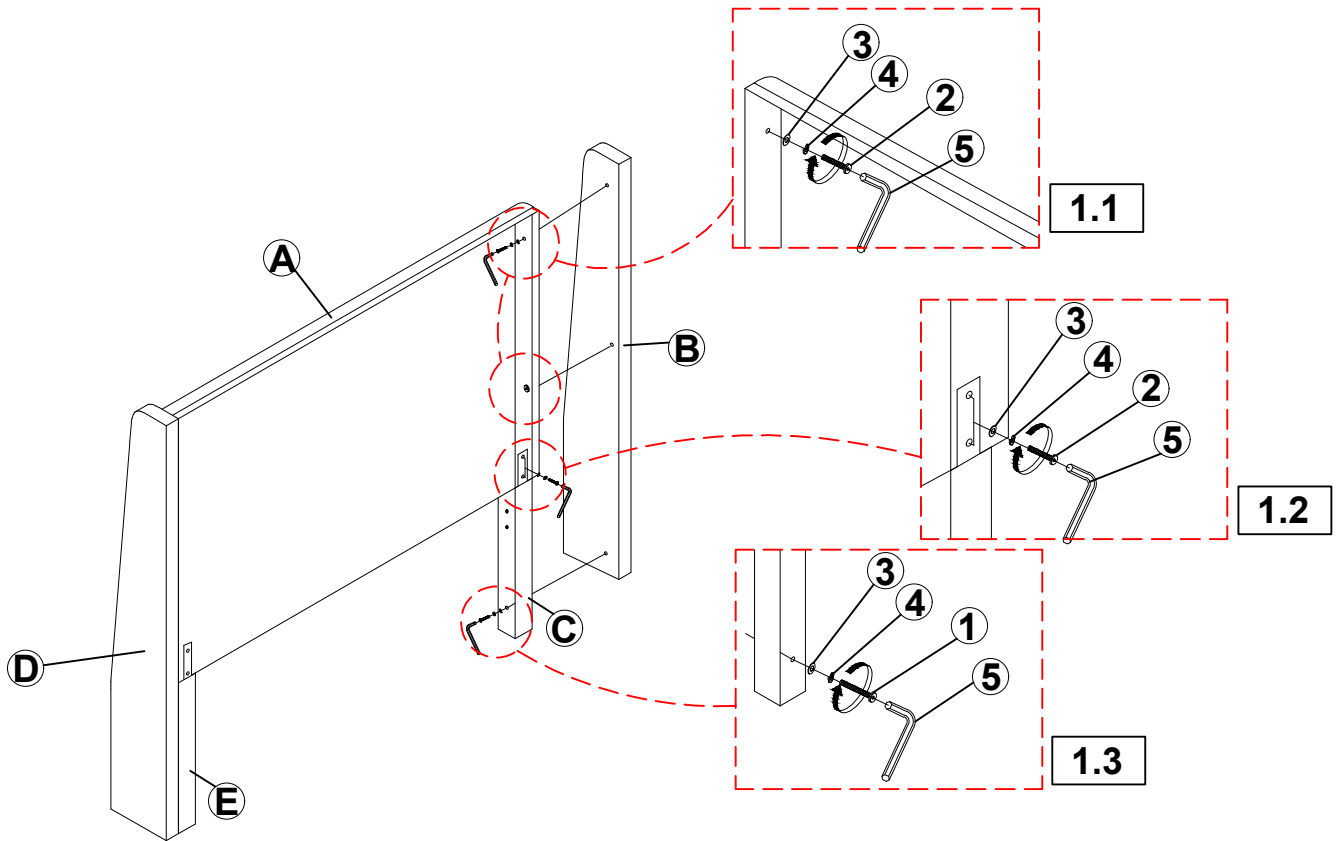

STEP 2

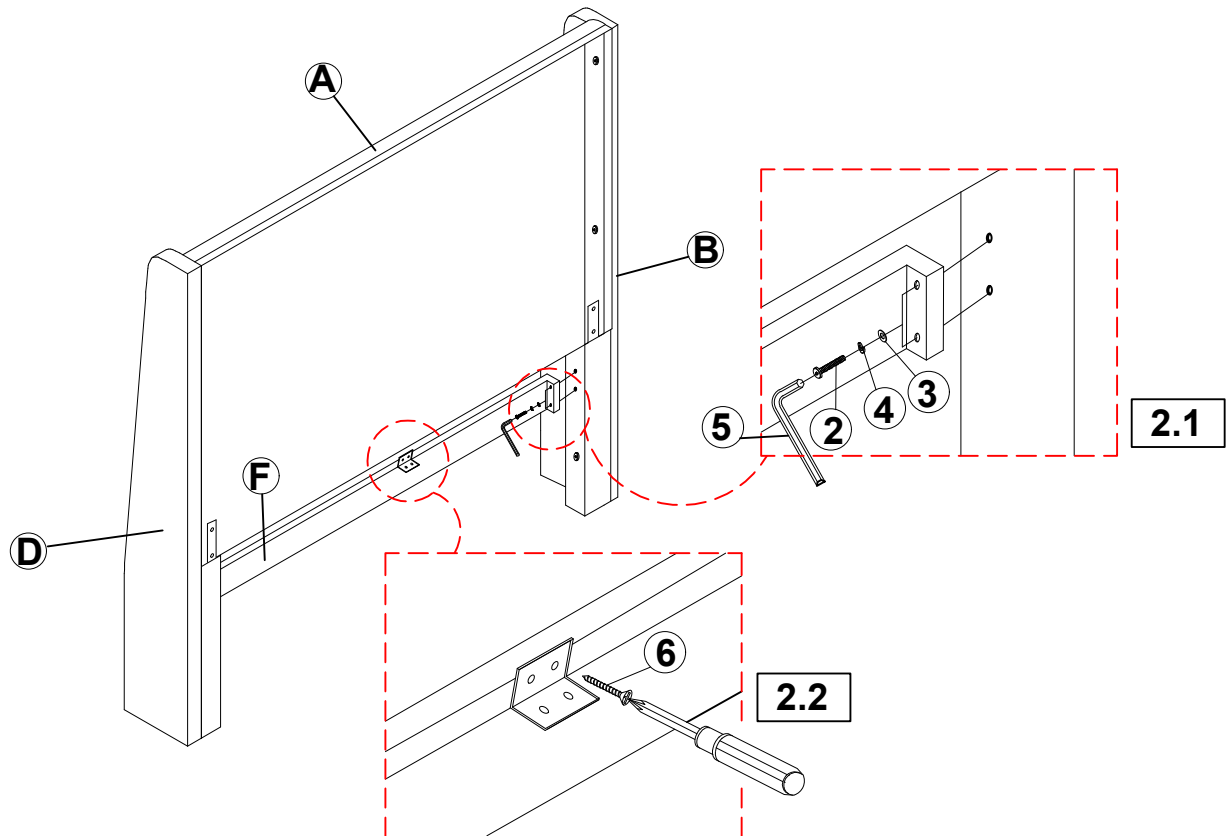

ITEM: 315983Q(B1&B2)

ASSEMBLY INSTRUCTIONS

STEP 3

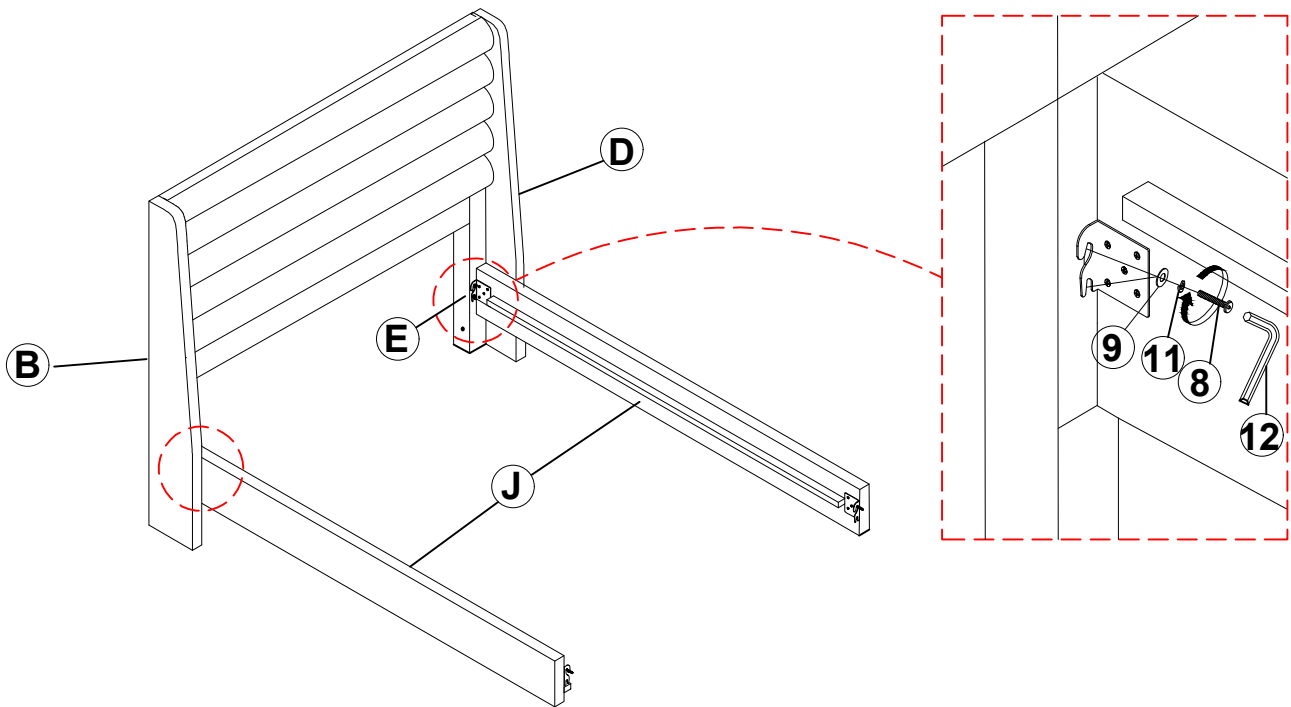

STEP 4

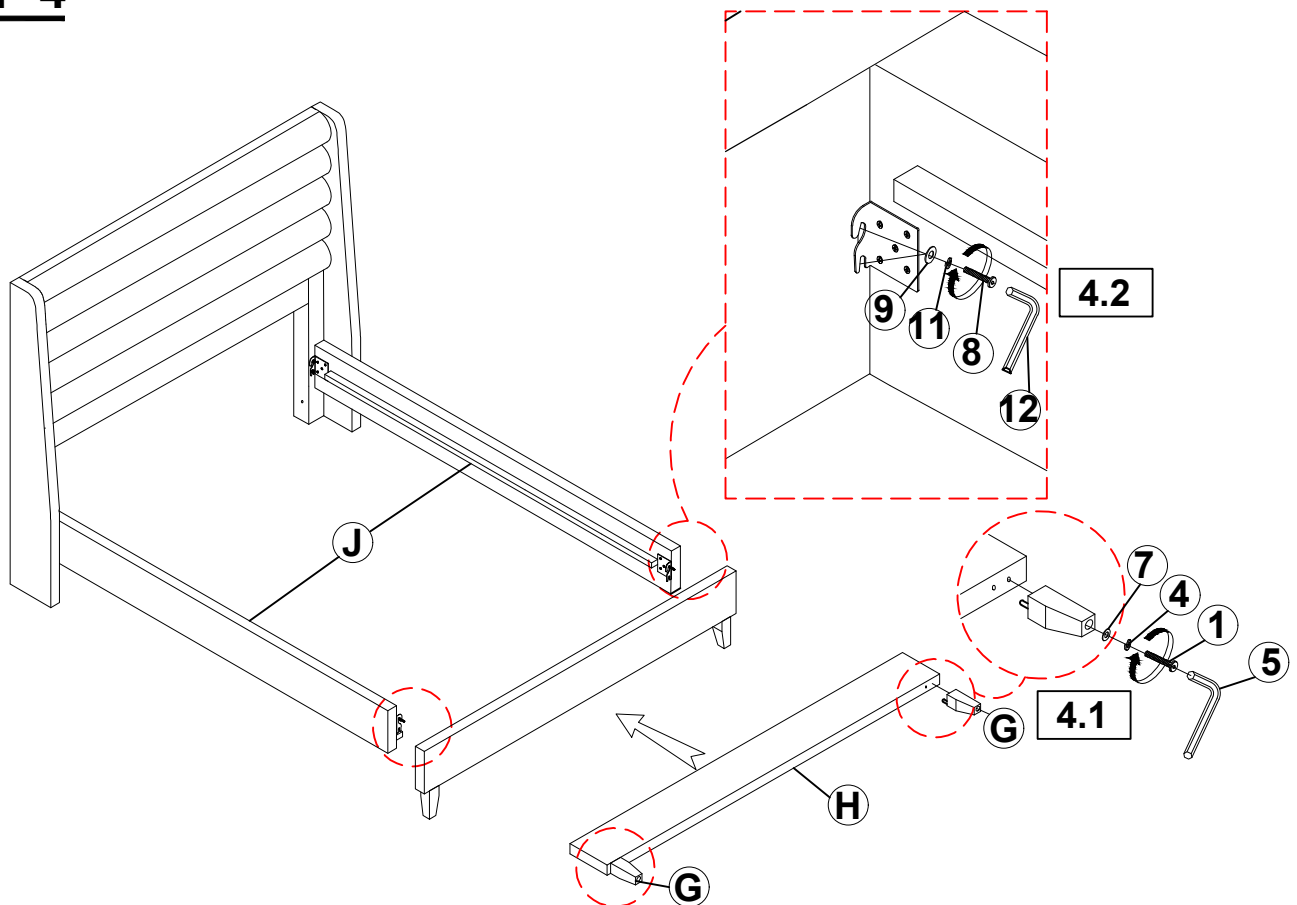

ITEM: **315983Q(B1&B2)**

ASSEMBLY INSTRUCTIONS

STEP 5

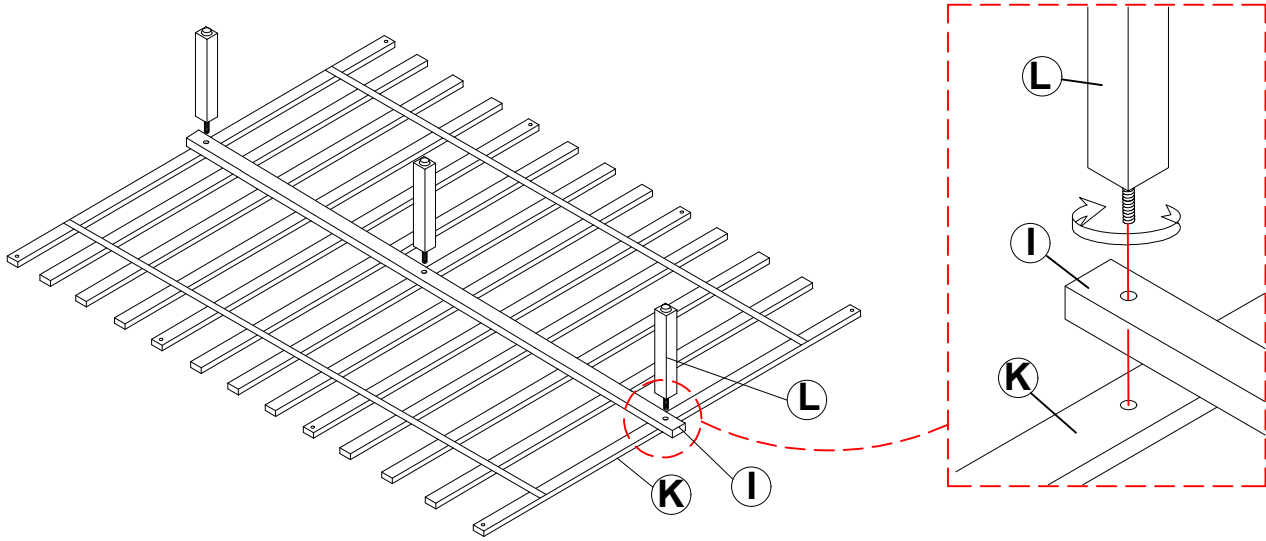

STEP 6
COMPLETE

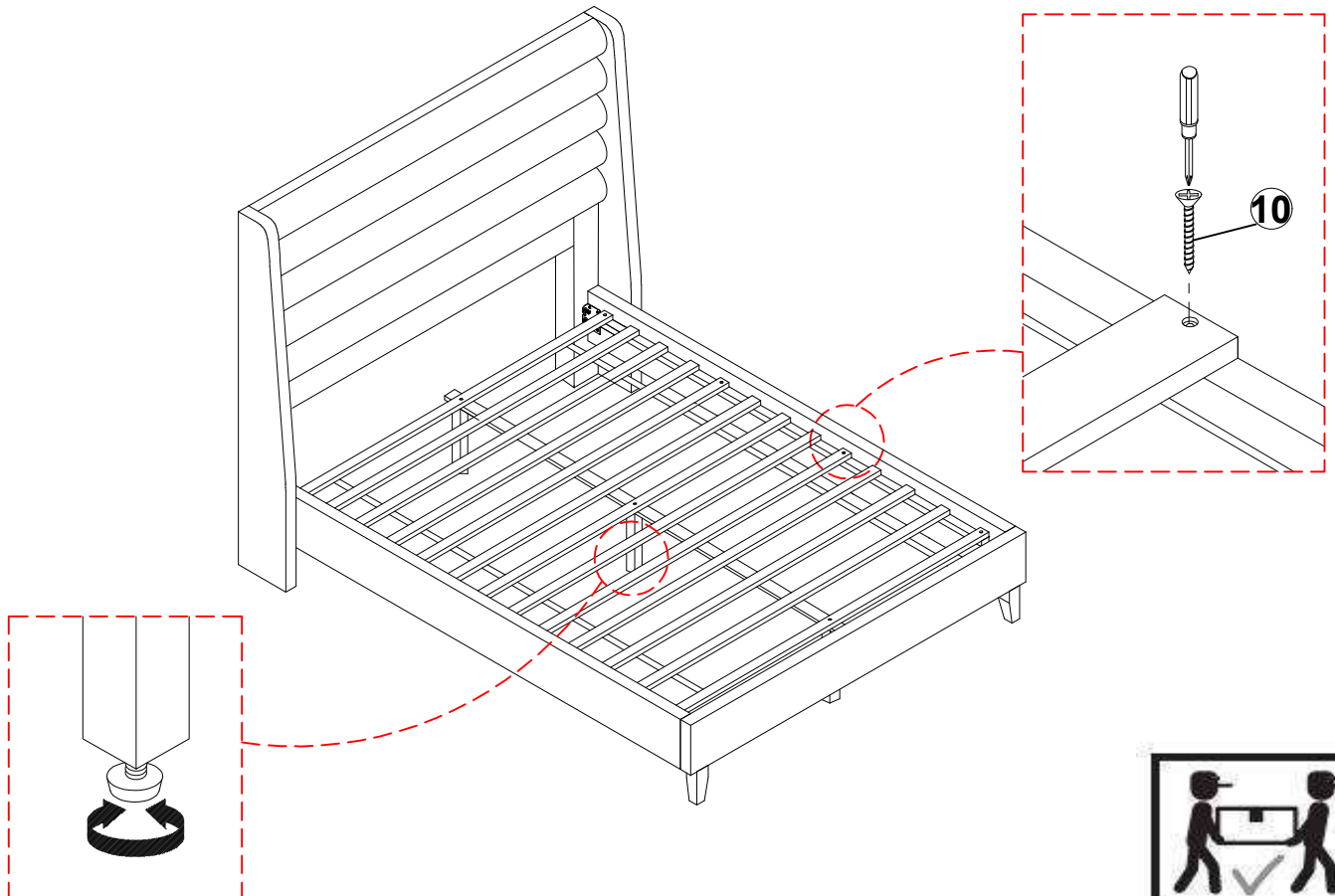

ITEM: **315983Q(B1&B2)**



Inner size: **61.00"W x 81.00"D**

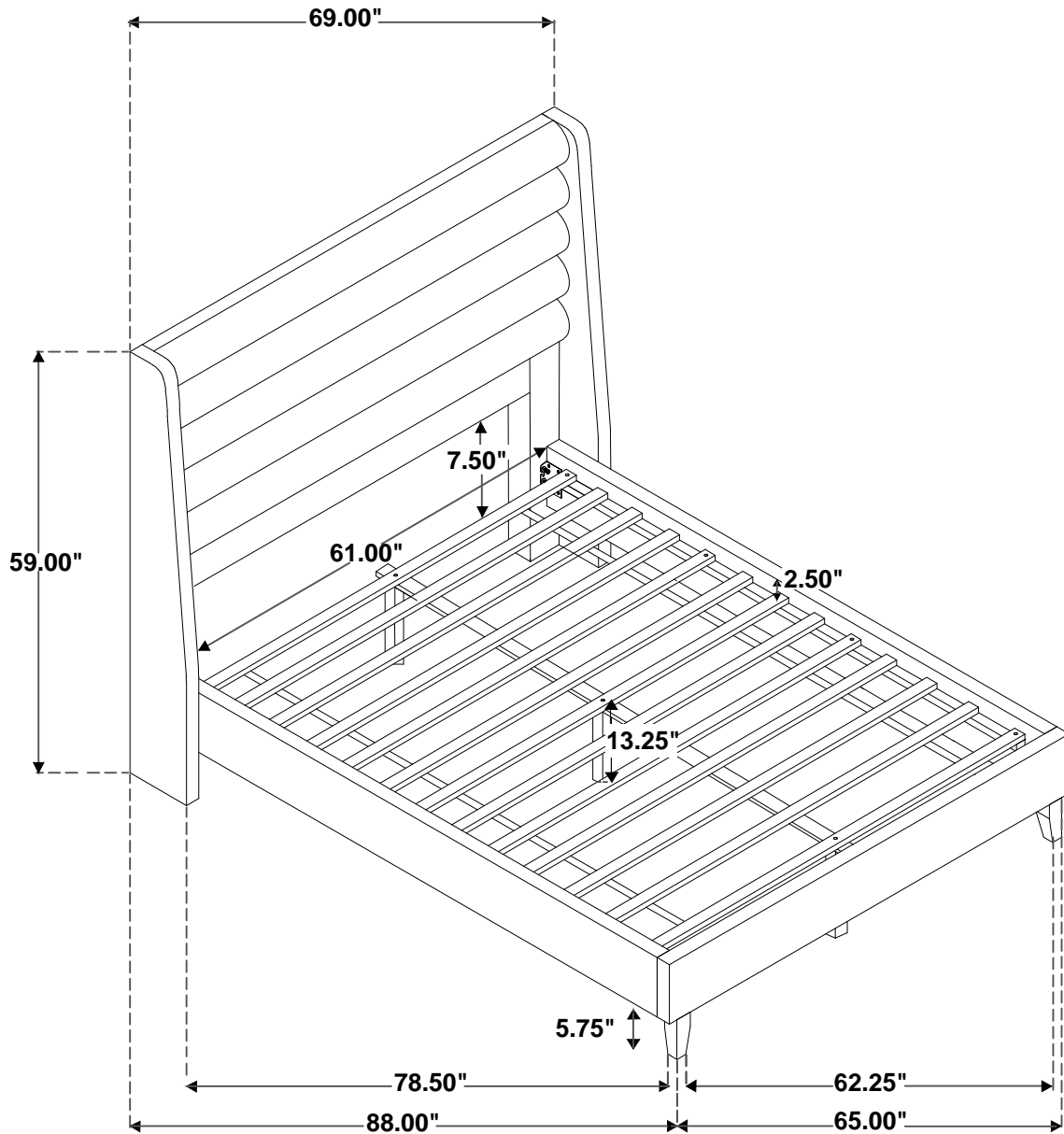

Note: Dimension tolerance $\pm 5\%$