

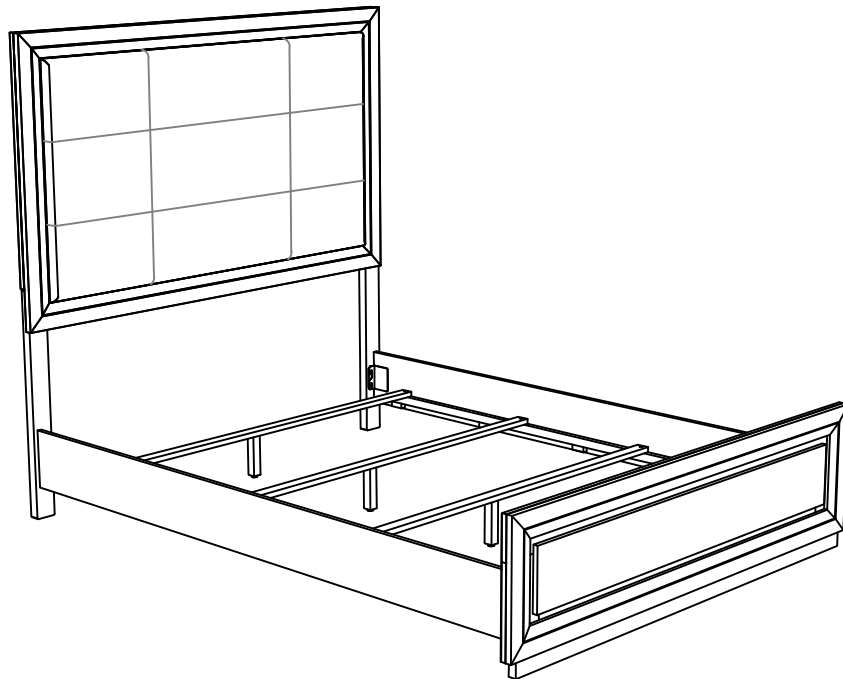

# ASSEMBLY INSTRUCTIONS COASTER FINE FURNITURE



Fine Furniture for every stage of life

## 215971Q(B1&B2) Queen Bed

# ITEM: 215971Q(B1&B2)



## ASSEMBLY INSTRUCTIONS

### ASSEMBLY TIPS:

- 1.Remove hardware from box and sort by size.
- 2.Please check to see that all hardware and parts are present prior to start of assembly.
- 3.Please follow attached instructions in the same sequence as numbered to assure fast & easy assembly.



### WARNING!

- 1.Don't attempt to repair or modify parts that are broken or defective. Please contact the store immediately.
- 2.This product is for home use only and not intended for commercial establishments.



ASSEMBLY TIME

20 MINUTES

## PARTS IDENTIFICATION

### B1 (BOX 1)

A HEADBOARD PANEL

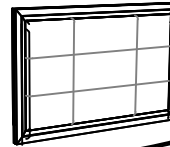

1PC

B FOOTBOARD



1PC

C LEFT HEADBOARD LEG



1PC

D RIGHT HEADBOARD LEG

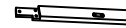

1PC

E BED SLAT



4PCS

F BED SLAT SUPPORT WITH LEVELER



4PCS

### B2 (BOX 2)

G BED RAIL



2PCS

HB 215971Q(B1) FROM BOX 1  
HEADBOARD COMPLETE

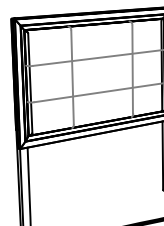

1PC

B 215971Q(B1) FROM BOX 1  
FOOTBOARD

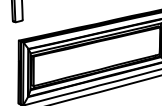

1PC

# ITEM: 215971Q(B1&B2)



## ASSEMBLY INSTRUCTIONS

### ASSEMBLY TIPS:

- 1.Remove hardware from box and sort by size.
- 2.Please check to see that all hardware and parts are present prior to start of assembly.
- 3.Please follow attached instructions in the same sequence as numbered to assure fast & easy assembly.







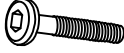

### WARNING!

- 1.Don't attempt to repair or modify parts that are broken or defective. Please contact the store immediately.
- 2.This product is for home use only and not intended for commercial establishments.

## HARDWARE IDENTIFICATION

### Z-B1(BOX 1) - HARDWARE PACK IS LOCATED IN 215971Q(B1)

1	<b>BOLT</b> (M6 x 30mm - BLK)		6PCS
2	<b>LOCK WASHER</b> (1/4" - BLK)		6PCS
3	<b>FLAT WASHER</b> (1/4" x 13mm - BLK)		6PCS
4	<b>FLAT HEAD SCREW</b> (M4 x 32mm - RBW)		8PCS
5	<b>SMALL ALLEN WRENCH</b> (M4 x 65mm - BLK)		1PC
6	<b>BIG ALLEN WRENCH</b> (M5 x 65mm - BLK)		1PC

### NOTE:

Phillips head screw driver is required in the assembly process; however, manufacturer does not provide this item.

# ITEM: 215971Q(B1&B2)

## ASSEMBLY INSTRUCTIONS



### STEP 1

Note : Please put item on soft surface.

Please take note of the marking sticker (L&R) on the leg.

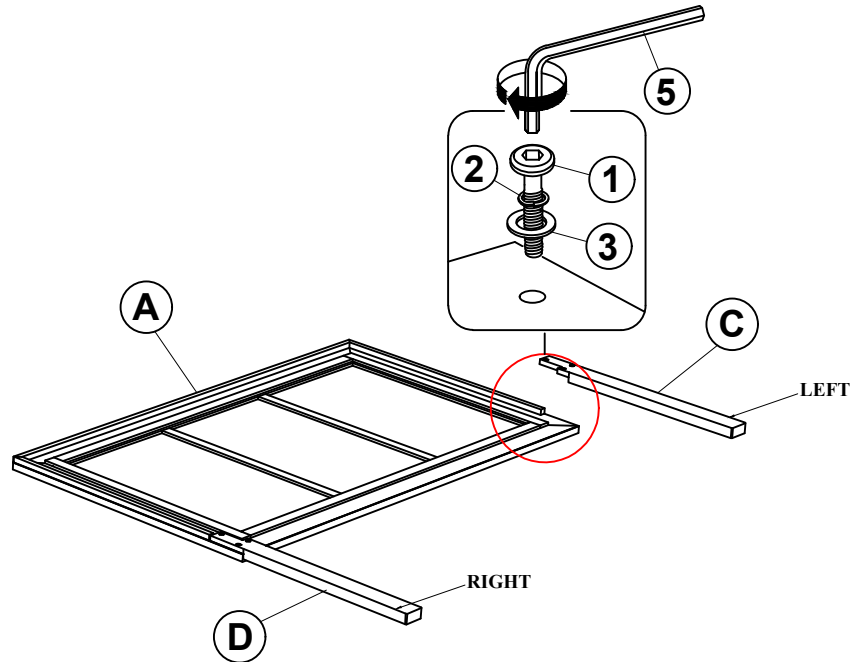

**\*\*BACK VIEW\*\***

### STEP 2

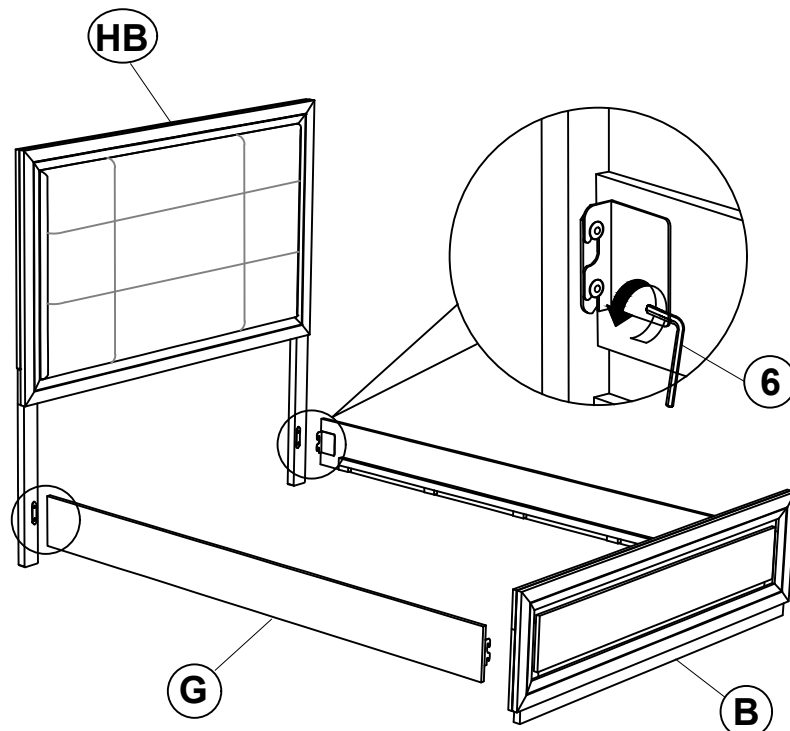

# ITEM: 215971Q(B1&B2)

## ASSEMBLY INSTRUCTIONS



### STEP 3

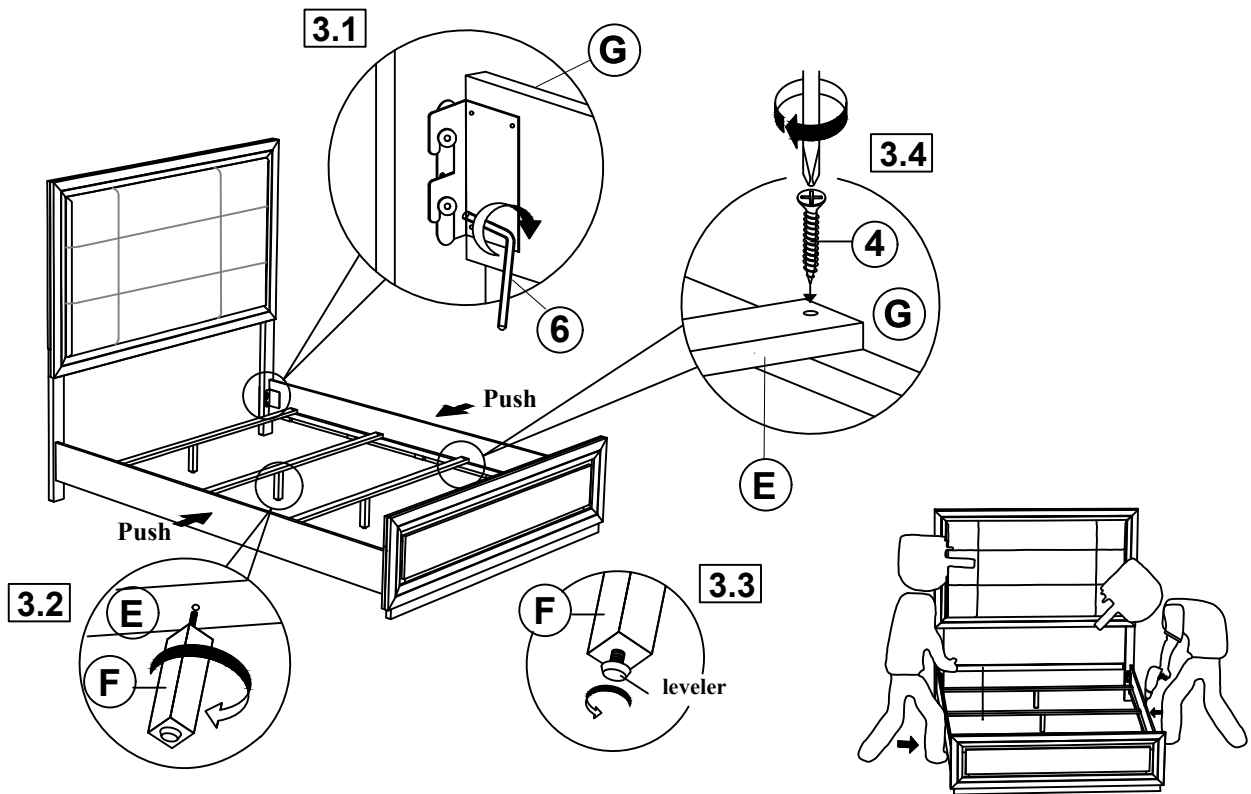

**NOTE:**

1. Push the side rail inward until the slats are flush and resting on the side rail support then fasten each slat to the side rail support using the provided screw.
2. The side rail warpage is a temporary condition, it will straighten out once the bed is fully assembled.

### STEP 4 **COMPLETE**

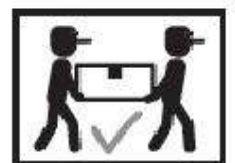
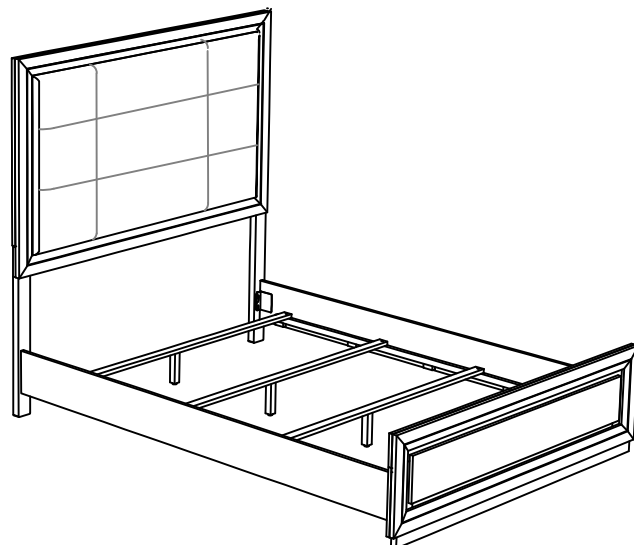

# ITEM: 215971Q(B1&B2)



Inner Size : 60.75"W x 81.00"D

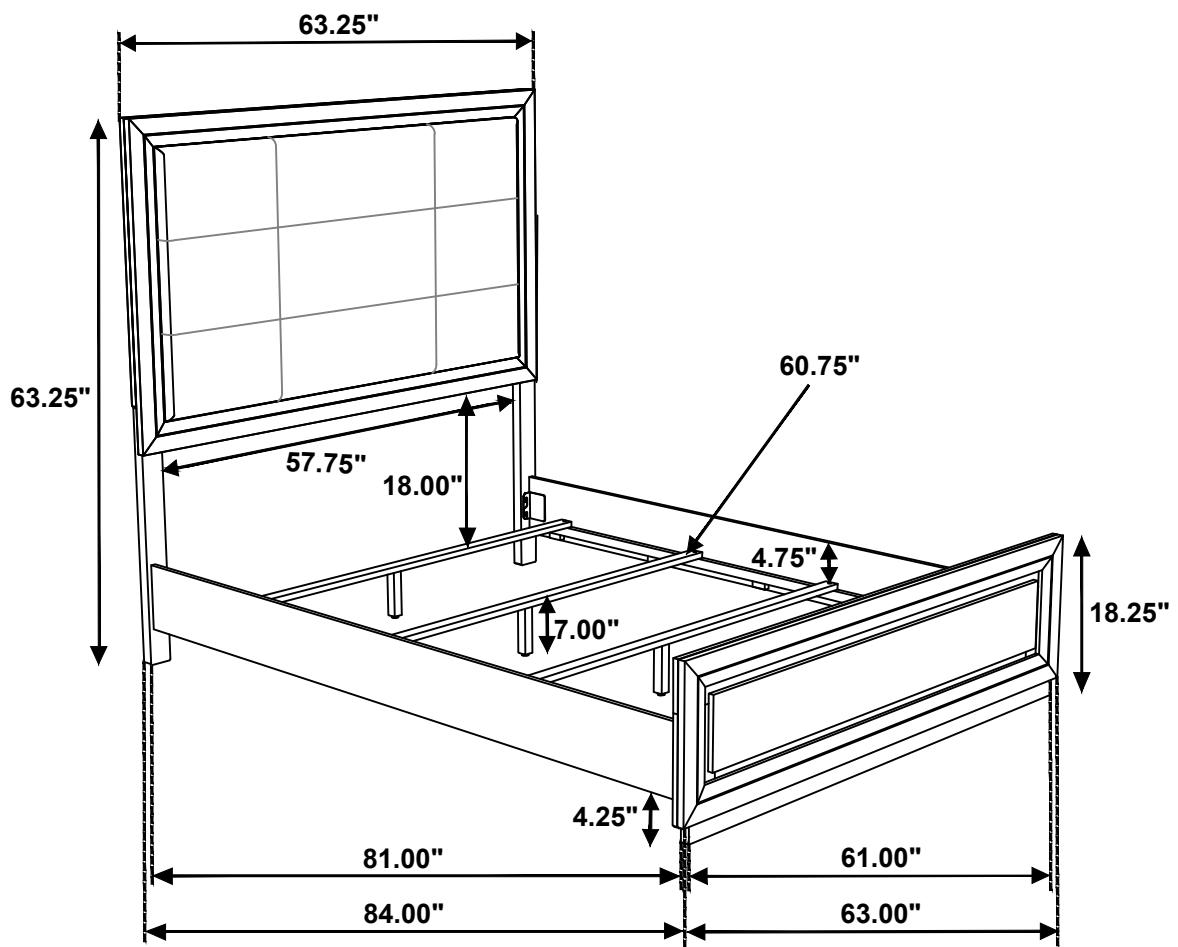

Note : Dimension tolerance  $\pm 5\%$