

**ASSEMBLY INSTRUCTIONS**  
**COASTER FINE FURNITURE**

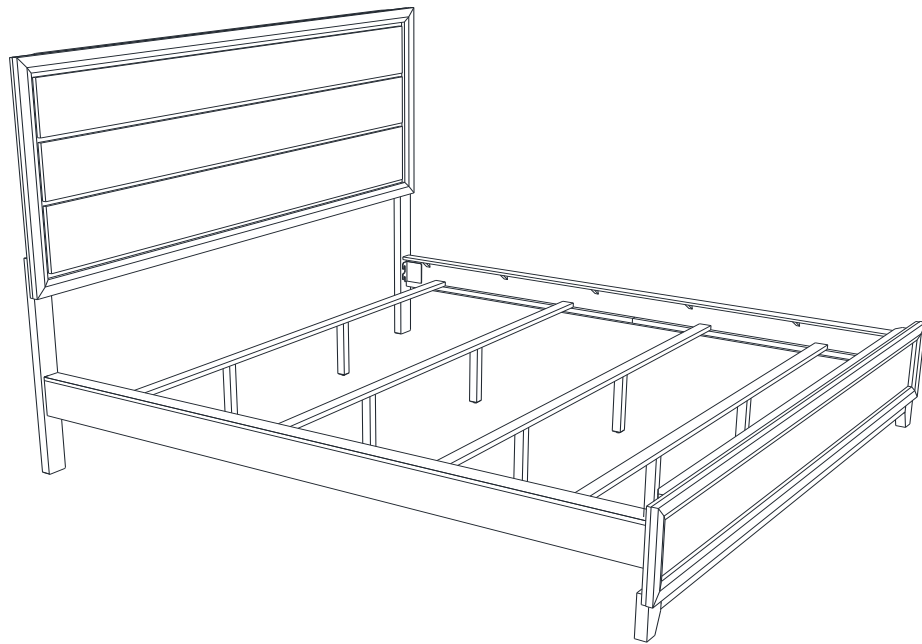

*Fine Furniture for every stage of life*

**215911KW(B1&B2)**  
**California King Bed**

# ITEM: 215911KW (B1&B2)



## ASSEMBLY INSTRUCTIONS

### ASSEMBLY TIPS:

1. Remove hardware from box and sort by size.
2. Please check to see that all hardware and parts are present prior to start of assembly.
3. Please follow attached instructions in the same sequence as numbered to assure fast & easy assembly.



### WARNING!

1. Don't attempt to repair or modify parts that are broken or defective. Please contact the store immediately.
2. This product is for home use only and not intended for commercial establishments.









ASSEMBLY TIME

20 MINUTES

## PARTS IDENTIFICATION

### B1 (BOX 1)



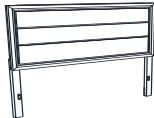
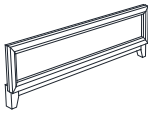

A	HEADBOARD PANEL		1PC	D	LEFT HEADBOARD LEG		1PC
B	FOOTBOARD		1PC	E	BED SLAT		4PCS
C	RIGHT HEADBOARD LEG		1PC	F	BED SLAT SUPPORT WITH LEVELER		8PCS

### B2 (BOX 2)

G	BED RAIL		2PCS				
HB	215911KW(B1) FROM BOX 1 HEADBOARD COMPLETE		1PC	B	215911KW(B1) FROM BOX 1 FOOTBOARD		1PC

## HARDWARE IDENTIFICATION

### Z-B1 (BOX 1) - HARDWARE PACK IS LOCATED IN 215911KW (B1)

1	BOLT (M6 x 30mm - BLK)		6PCS	4	SMALL ALLEN WRENCH (M4 x 60mm - BLK)		1PC
2	LOCK WASHER (1/4" - BLK)		6PCS	5	BIG ALLEN WRENCH (M5 x 65mm - BLK)		1PC
3	FLAT WASHER (1/4"ID x 13mm - BLK)		6PCS				

### Z-B2 (BOX 2) - HARDWARE PACK IS LOCATED IN 215911KW (B2)

6	PAN HEAD SCREW (M3.5 x 16mm - BLK)		16PCS	7	L-BRACKET		8PCS
---	------------------------------------	---	-------	---	-----------	---	------

### NOTE:

Phillips head screw driver is required in the assembly process; however, manufacturer does not provide this item.

# ITEM: 215911KW (B1&B2)

## ASSEMBLY INSTRUCTIONS

### STEP 1

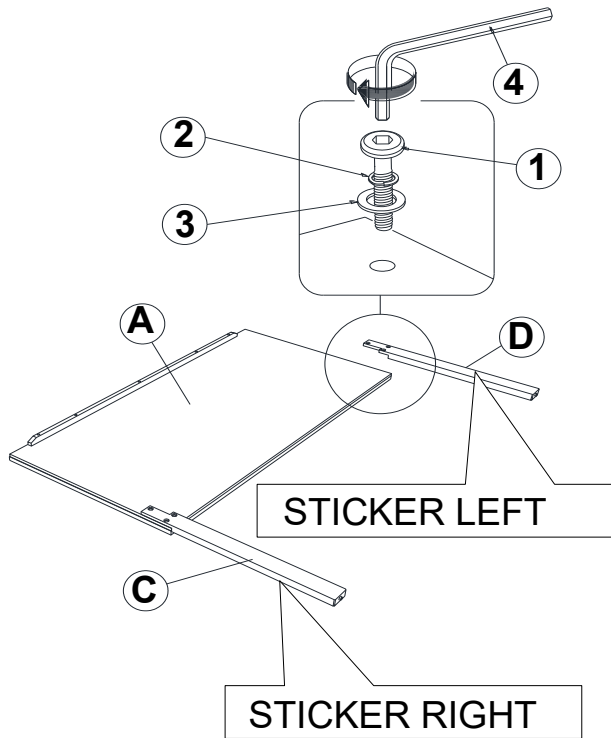

**\*\*BACK VIEW\*\***

**Note :** Please take note of the marking sticker (L & R) on the headboard legs.

### STEP 2

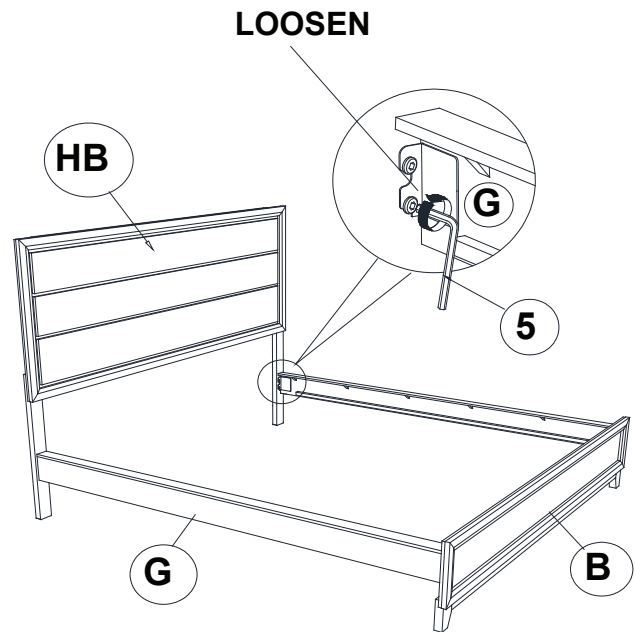

### STEP 3

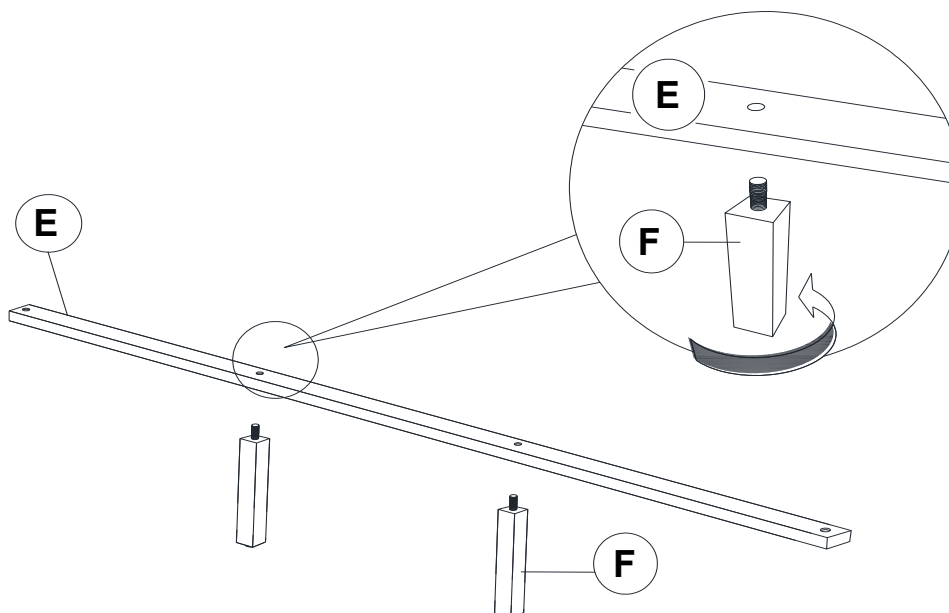

# ITEM: 215911KW (B1&B2)



## ASSEMBLY INSTRUCTIONS

### STEP 4

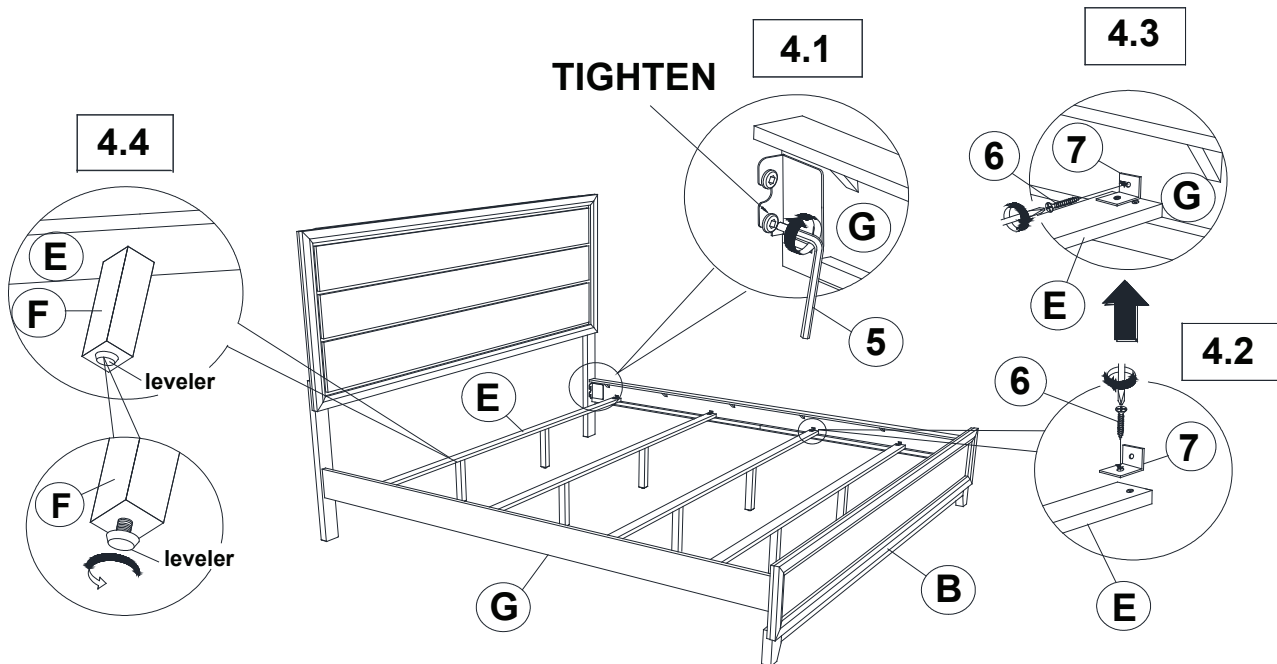

#### NOTE:

1. Push the side rail inward until the slats are flush and resting on the side rail support then fasten each slat to the side rail support using the provided screw.
2. The side rail warpage is a temporary condition, it will straighten out once the bed is fully assembled.

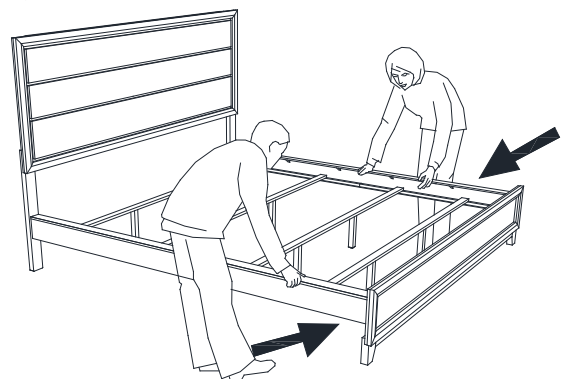

### STEP 5 COMPLETE

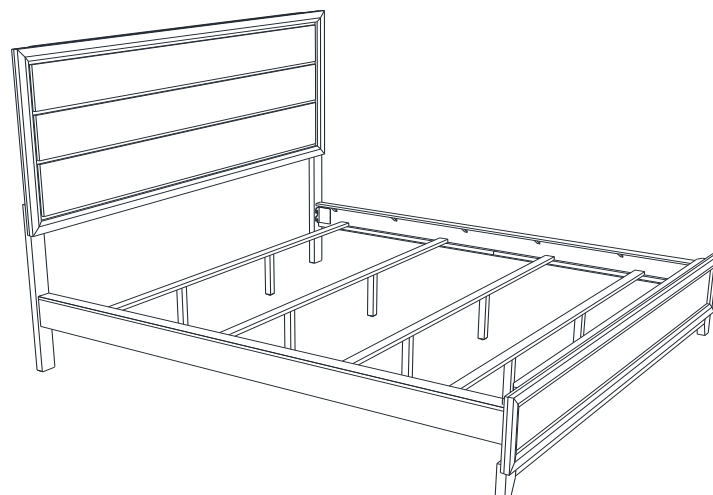

# ITEM: 215911KW (B1&B2)



Inner Size : 76.75"W X 86.00"D

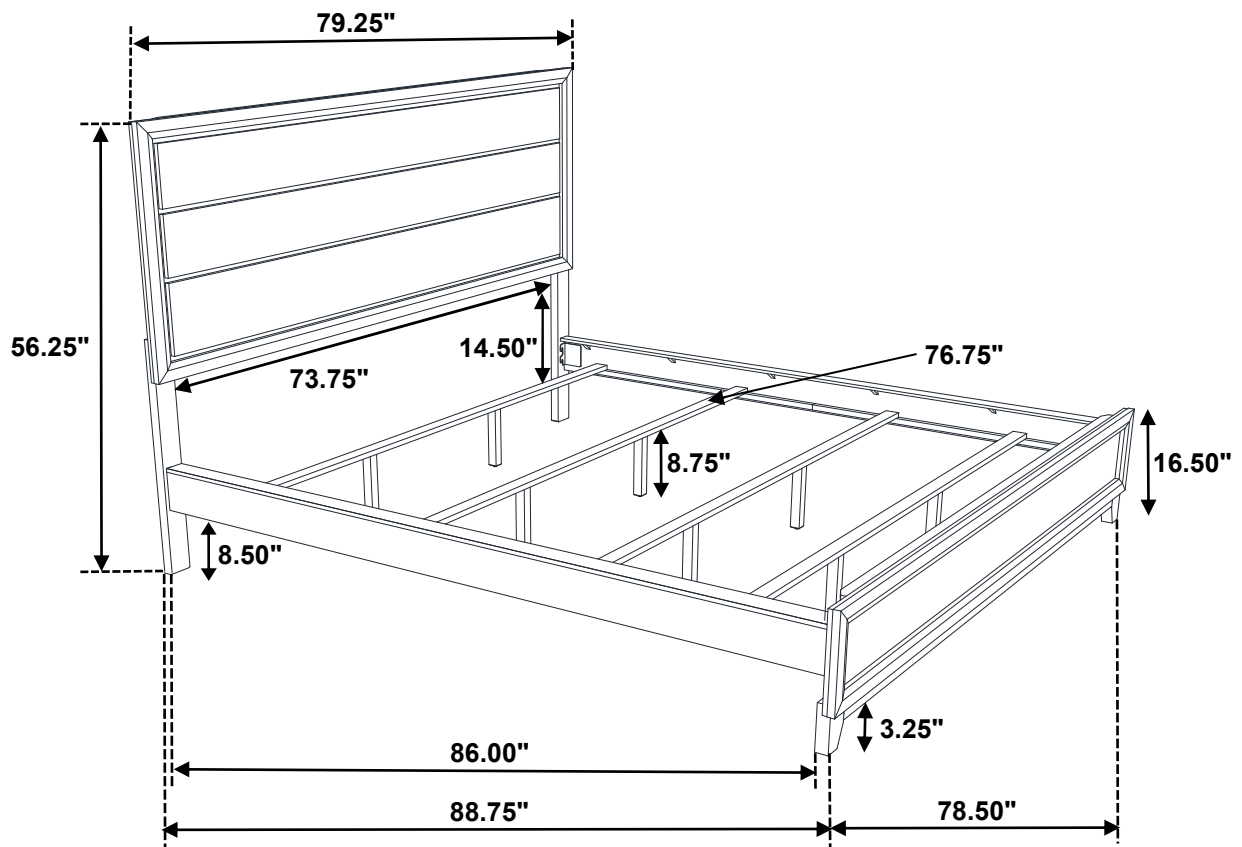

Note : Dimension tolerance  $\pm 5\%$