

ASSEMBLY INSTRUCTIONS
COASTER FINE FURNITURE



Fine Furniture for every stage of life

706567
END TABLE

ITEM: 706567



ASSEMBLY INSTRUCTIONS

ASSEMBLY TIPS:

1. Remove hardware from box and sort by size.
2. Please check to see that all hardware and parts are present prior to start of assembly.
3. Please follow attached instructions in the same sequence as numbered to assure fast & easy assembly.



WARNING!

1. Don't attempt to repair or modify parts that are broken or defective. Please contact the store immediately.
2. This product is for home use only and not intended for commercial establishments.

ASSEMBLY TIME 25 MINUTES

PARTS IDENTIFICATION

A

TOP

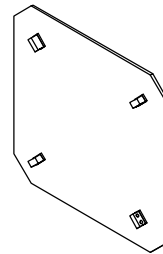

1PC

B

LEG B

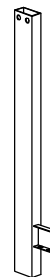

2PCS

C

LEG C



2PCS

D

LEG SUPPORT FRAME

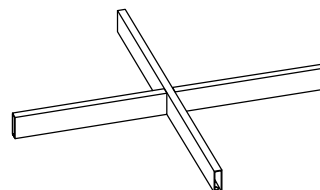

1PC

ITEM: 706567

ASSEMBLY INSTRUCTIONS



Z

HARDWARE IDENTIFICATION

1 BOLT
(1/4" x 12mm SR)



16PCS

3 COVER



8PCS

2 CAP
(20 x 40mm BLK)



4PCS

4 ALLEN WRENCH
(4mm)



1PC

STEP 1

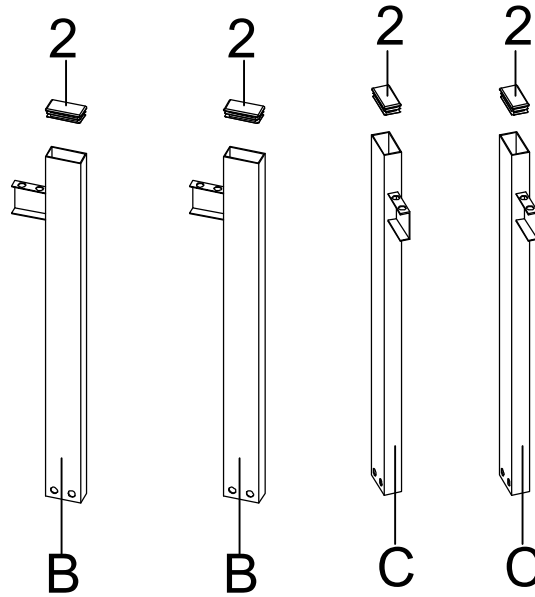

STEP 2

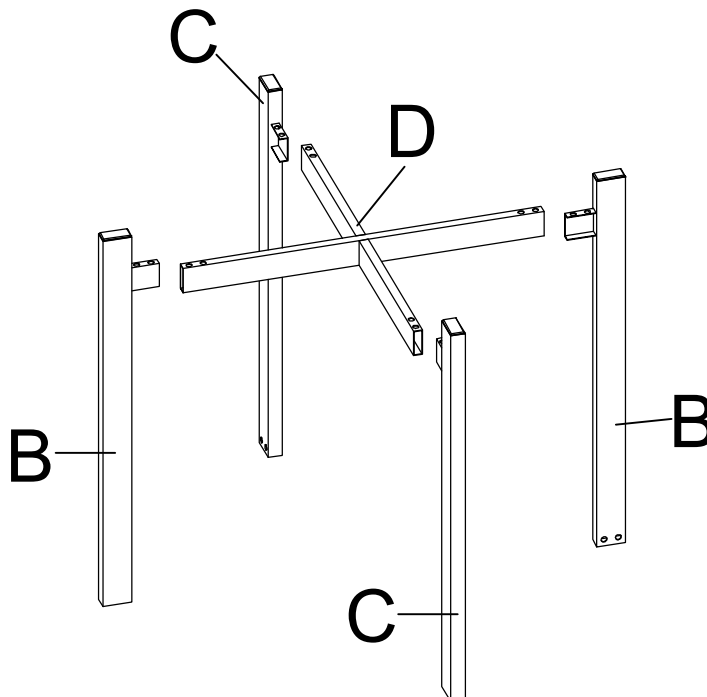

ITEM: 706567

ASSEMBLY INSTRUCTIONS

STEP 3

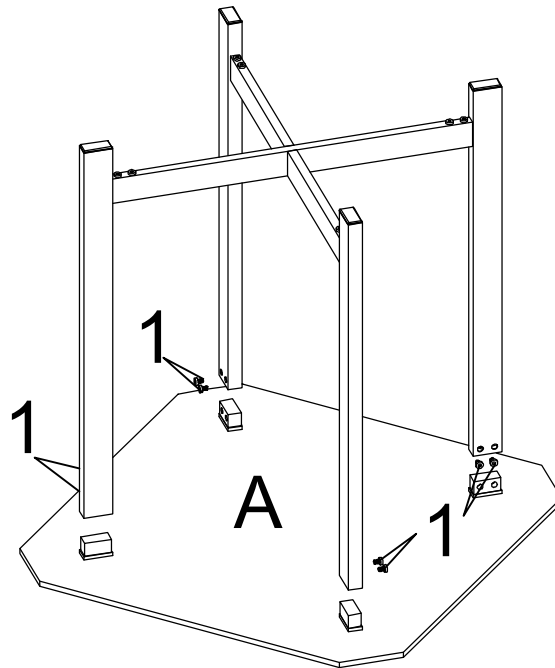

STEP 4

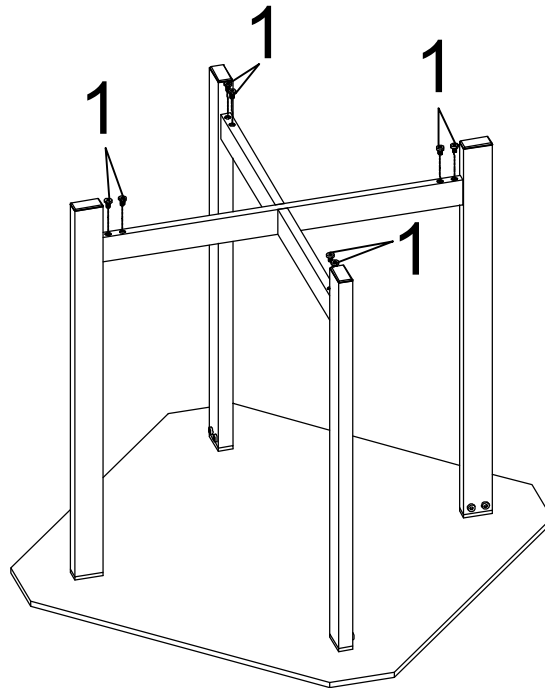

ITEM: 706567

ASSEMBLY INSTRUCTIONS

STEP 5

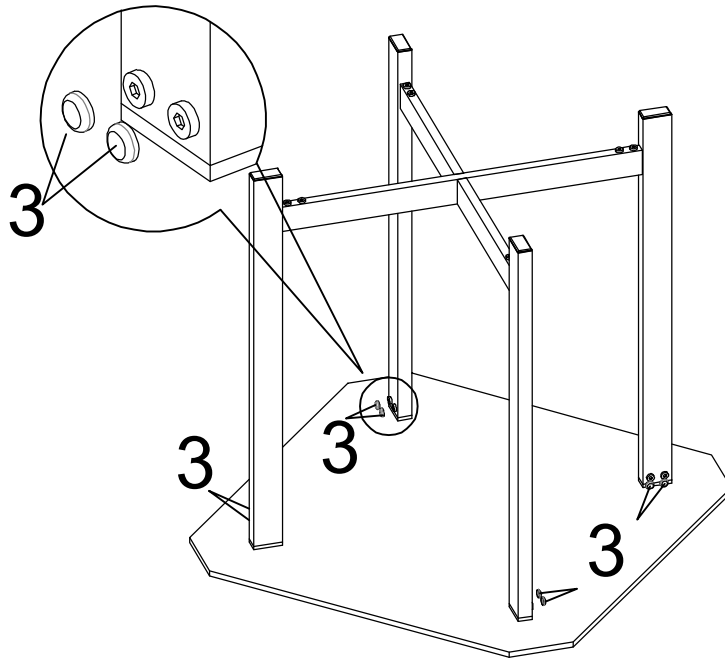

STEP 6

COMPLETE

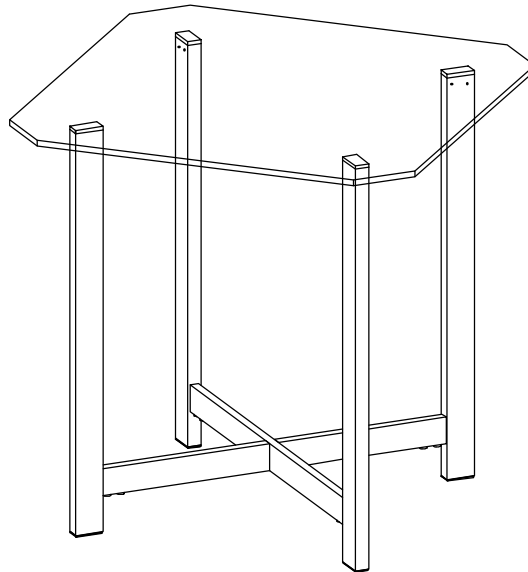

ITEM:706567

ASSEMBLY INSTRUCTIONS



Product Size : 578 X 578 X 591 H (MM)
Product Size : 22.75" X 22.75" X 23.25"

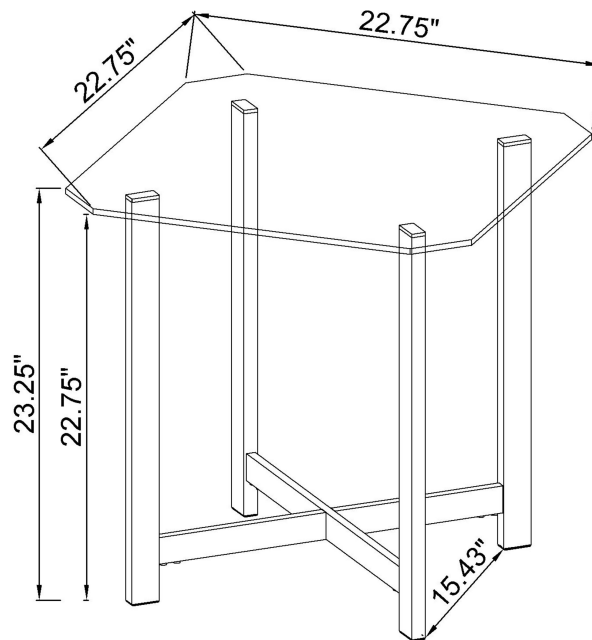

Note: Dimension tolerance $\pm 5\%$