

*ASSEMBLY INSTRUCTIONS  
COASTER FINE FURNITURE*



*Fine Furniture for every stage of life*

**802001**  
**WRITING DESK**

# ITEM:802001



## ASSEMBLY INSTRUCTIONS

### ASSEMBLY TIPS:

1. Remove hardware from box and sort by size.
2. Please check to see that all hardware and parts are present prior to start of assembly.
3. Please follow attached instructions in the same sequence as numbered to assure fast & easy assembly.



### WARNING!

1. Don't attempt to repair or modify parts that are broken or defective. Please contact the store immediately.
2. This product is for home use only and not intended for commercial establishments.

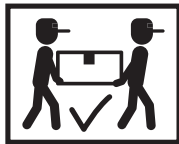

ASSEMBLY TIME

60 MINUTES

## PARTS IDENTIFICATION

|   |                     |  |      |   |                                |  |       |
|---|---------------------|--|------|---|--------------------------------|--|-------|
| A | LEFT SIDE PANEL     |  | 1 PC | J | DRAWER FRONT PANEL             |  | 2 PCS |
| B | RIGHT SIDE PANEL    |  | 1 PC | K | DRAWER BACK PANEL              |  | 2 PCS |
| C | LEFT DIVIDER PANEL  |  | 1 PC | L | DRAWER LEFT SIDE PANEL         |  | 2 PCS |
| D | RIGHT DIVIDER PANEL |  | 1 PC | M | DRAWER RIGHT SIDE PANEL        |  | 2 PCS |
| E | LEFT BOTTOM PANEL   |  | 1 PC | N | DRAWER BOTTOM PANEL            |  | 2 PCS |
| F | MIDDLE BOTTOM PANEL |  | 1 PC | O | MIDDLE DRAWER FRONT PANEL      |  | 1 PC  |
| G | RIGHT BOTTOM PANEL  |  | 1 PC | P | MIDDLE DRAWER BACK PANEL       |  | 1 PC  |
| H | BACK PANEL          |  | 1 PC | Q | MIDDLE DRAWER LEFT SIDE PANEL  |  | 1 PC  |
| I | TOP PANEL           |  | 1 PC | R | MIDDLE DRAWER RIGHT SIDE PANEL |  | 1 PC  |

### NOTE:

Phillips head screw driver is required in the assembly process; however, manufacturer does not provide this item.

# ITEM:802001

S MIDDLE DRAWER BOTTOM PANEL 1 PC

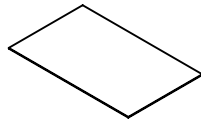

U CROSSBAR 1 PC

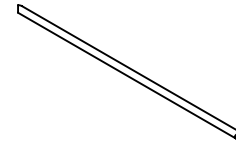



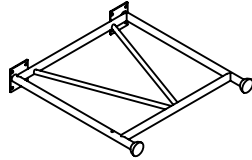





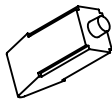

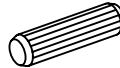

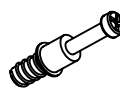
T LEG FRAME 2 PCS



## Z

## HARDWARE IDENTIFICATION

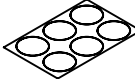
| NO | DESCRIPTION                 | FIGURE  | Q'TY   | NO | DESCRIPTION                 | FIGURE  | Q'TY   |
|----|-----------------------------|---|--------|----|-----------------------------|---|--------|
| 1  | GLUE 40g                    |    | 1 PC   | 8  | GLIDES SCREW<br>Ø 3x12mm SR |    | 36 PCS |
| 2  | WOODEN DOWEL<br>Ø 8x30mm    |  | 45 PCS | 9  | KNOB                        |  | 3 PCS  |
| 3  | CAM BOLT<br>Ø 7x35.5mm SR   |  | 20 PCS | 10 | KNOB BOLT<br>Ø 4x28mm BLK   |  | 3 PCS  |
| 4  | CAM LOCK<br>Ø 15x12mm SR    |  | 20 PCS | 11 | BOLT<br>M 6x20mm BLK        |  | 16 PCS |
| 5  | LONG SCREW<br>Ø 4.5x42mm SR |  | 16 PCS | 12 | LONG BOLT<br>M 6x44mm BLK   |  | 2 PCS  |
| 6  | SCREW<br>Ø 4.3x35mm SR      |  | 12 PCS | 13 | ALLEN WRENCH<br>4mm SR      |  | 1 PC   |
| 7  | GLIDES<br>L = 350mm WHT     |  | 3SET   | 14 | STICKER<br>Ø 20mm           |  | 4 PCS  |

Z7,Z9,Z10 not included in blister packaging.

### NOTE:

Phillips head screw driver is required in the assembly process; however, manufacturer does not provide this item.

ITEM: 802001

**COASTER**  
FINE FURNITURE

**STEP 1**

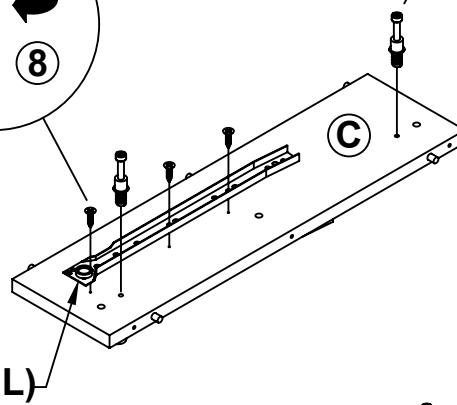
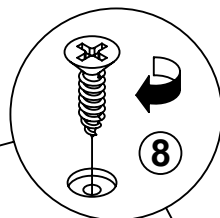
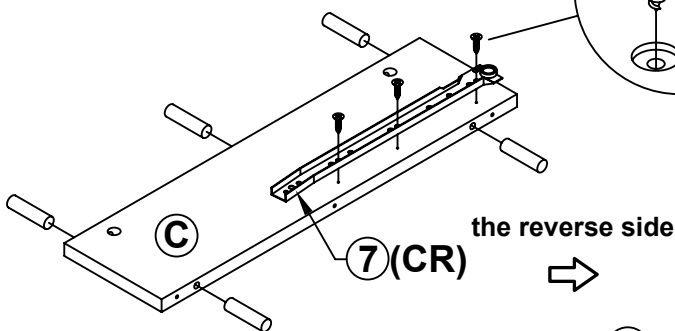
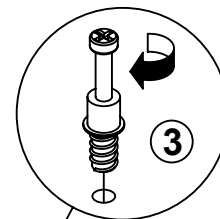
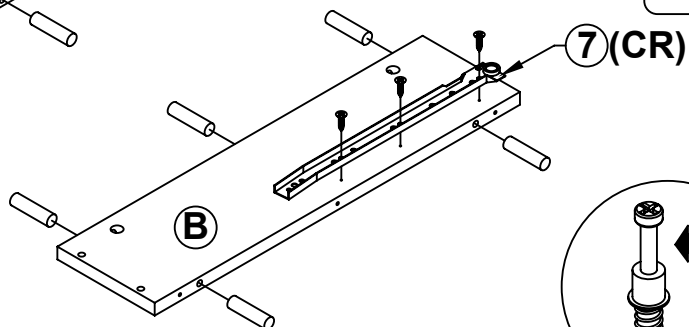
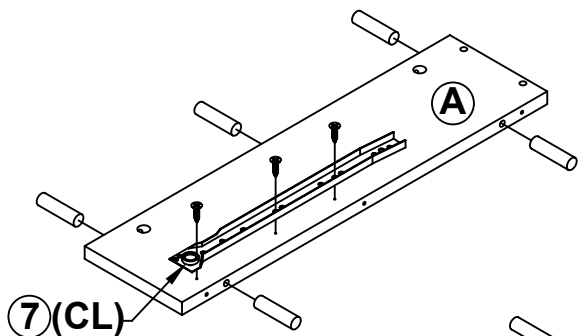
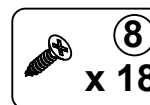
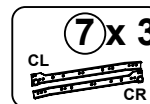
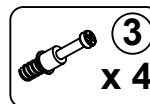
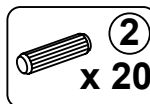

the reverse side

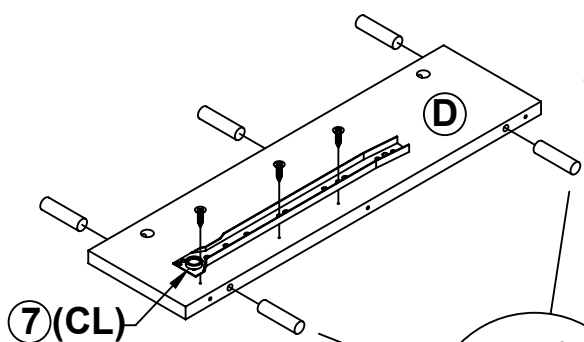

the reverse side

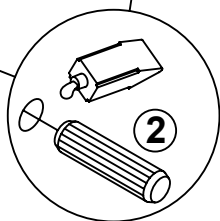
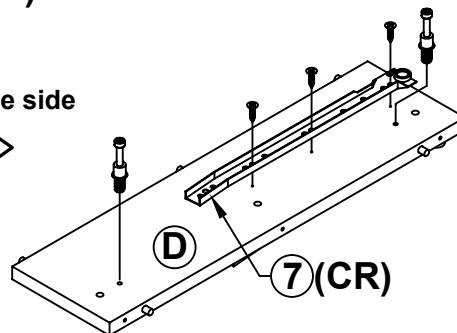

INCORRECT  
CORRECT

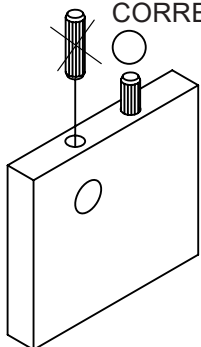

Apply glue on all wooden dowels to ensure integrity of the structure.

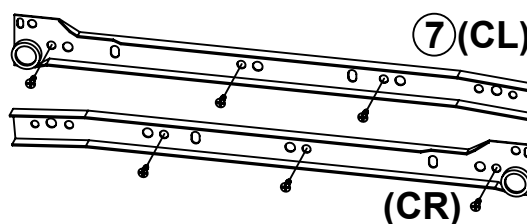

ITEM: 802001

**STEP 2**

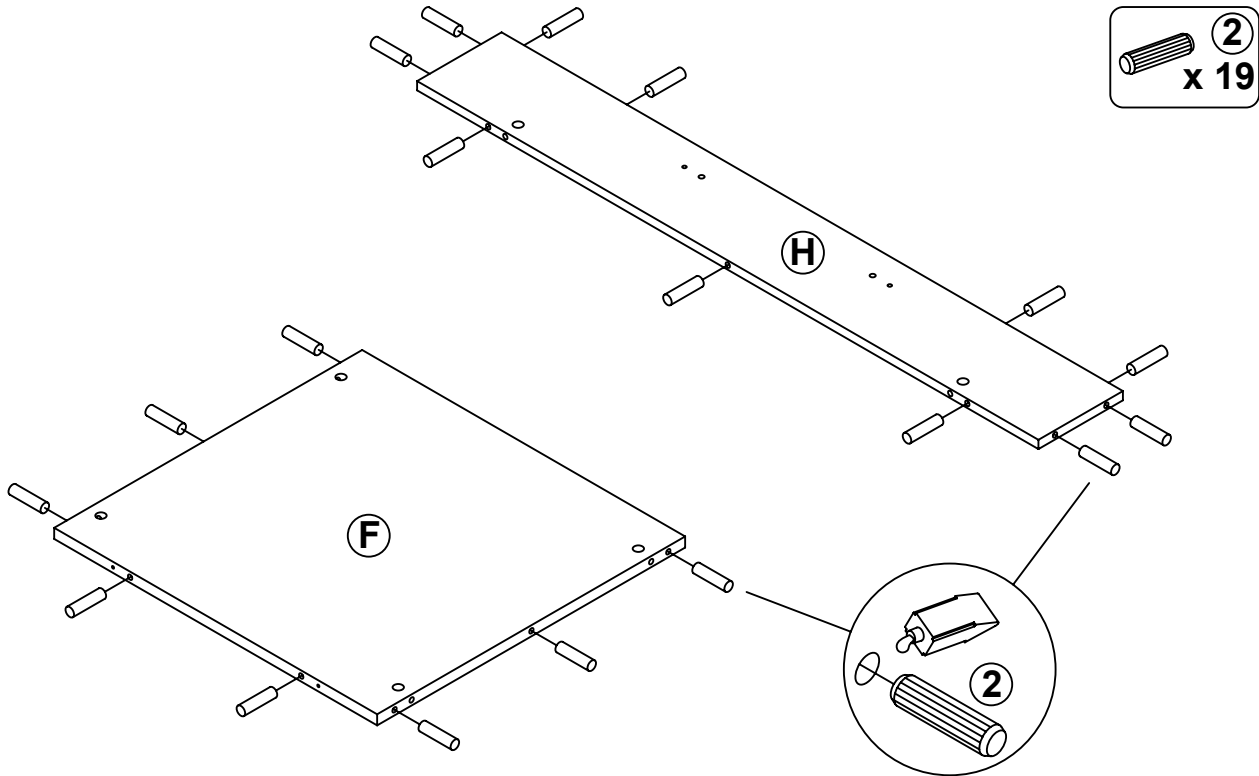

Apply glue on all wooden dowels to ensure integrity of the structure.

**STEP 3**

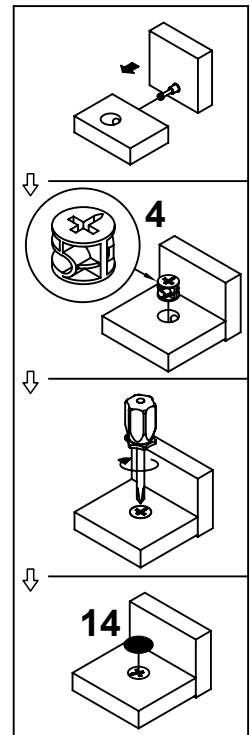
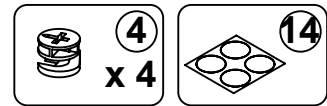
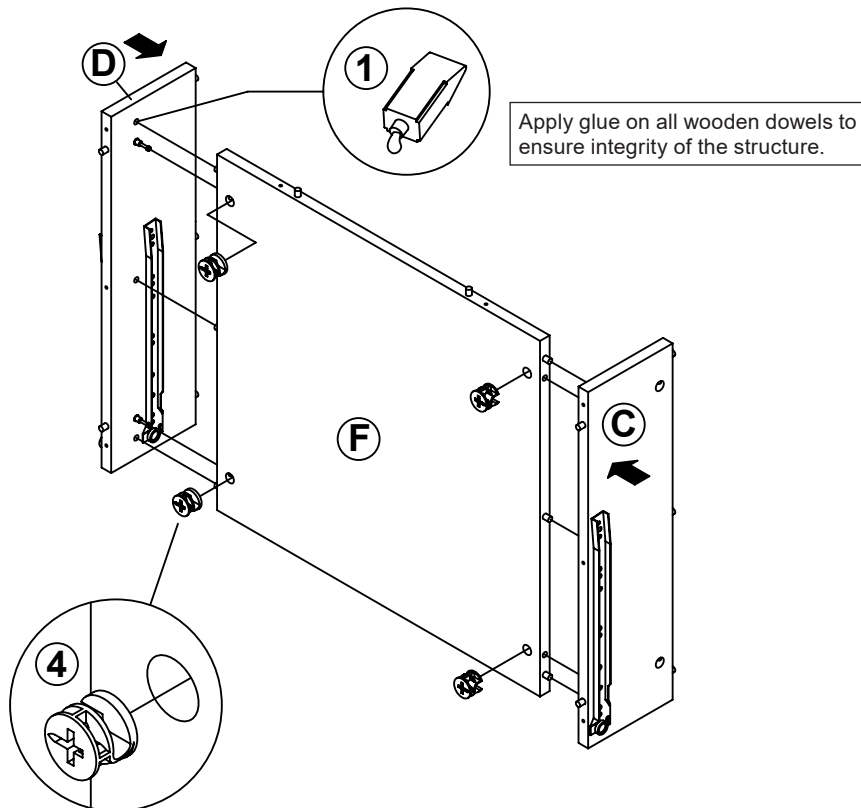

ITEM: 802001

**STEP 4**

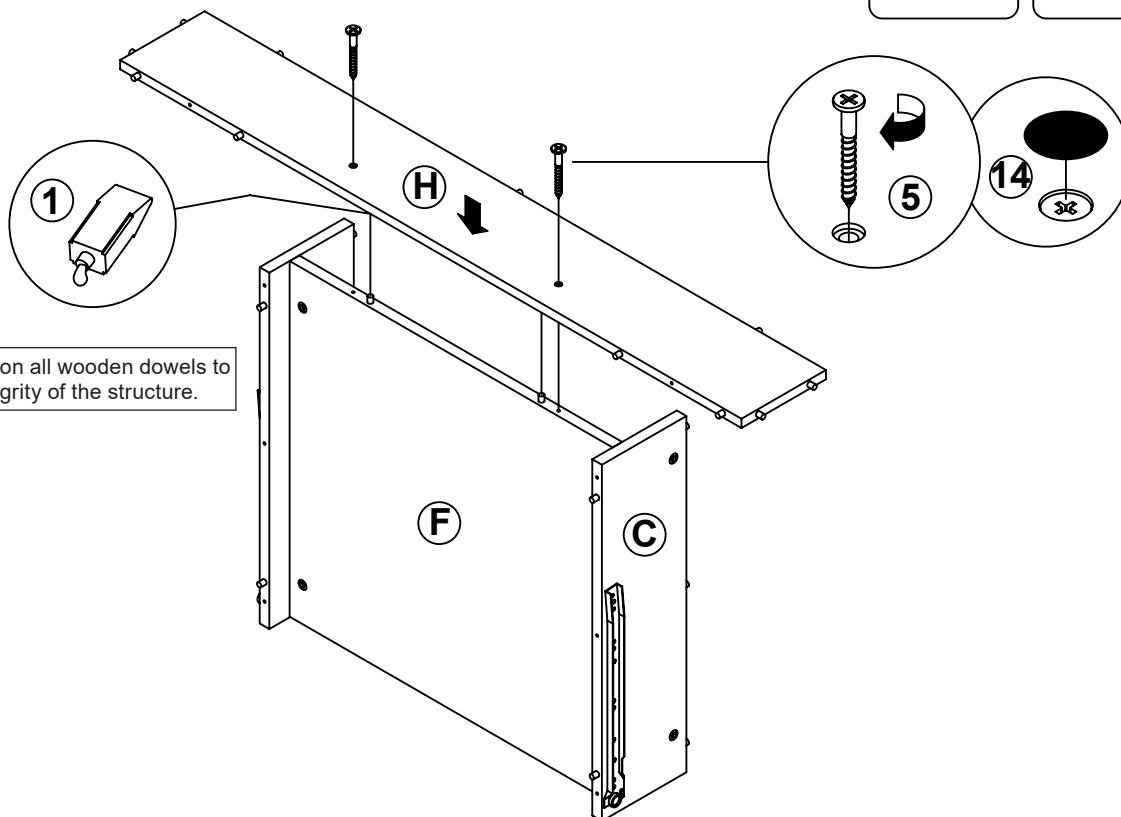

Apply glue on all wooden dowels to ensure integrity of the structure.

**STEP 5**

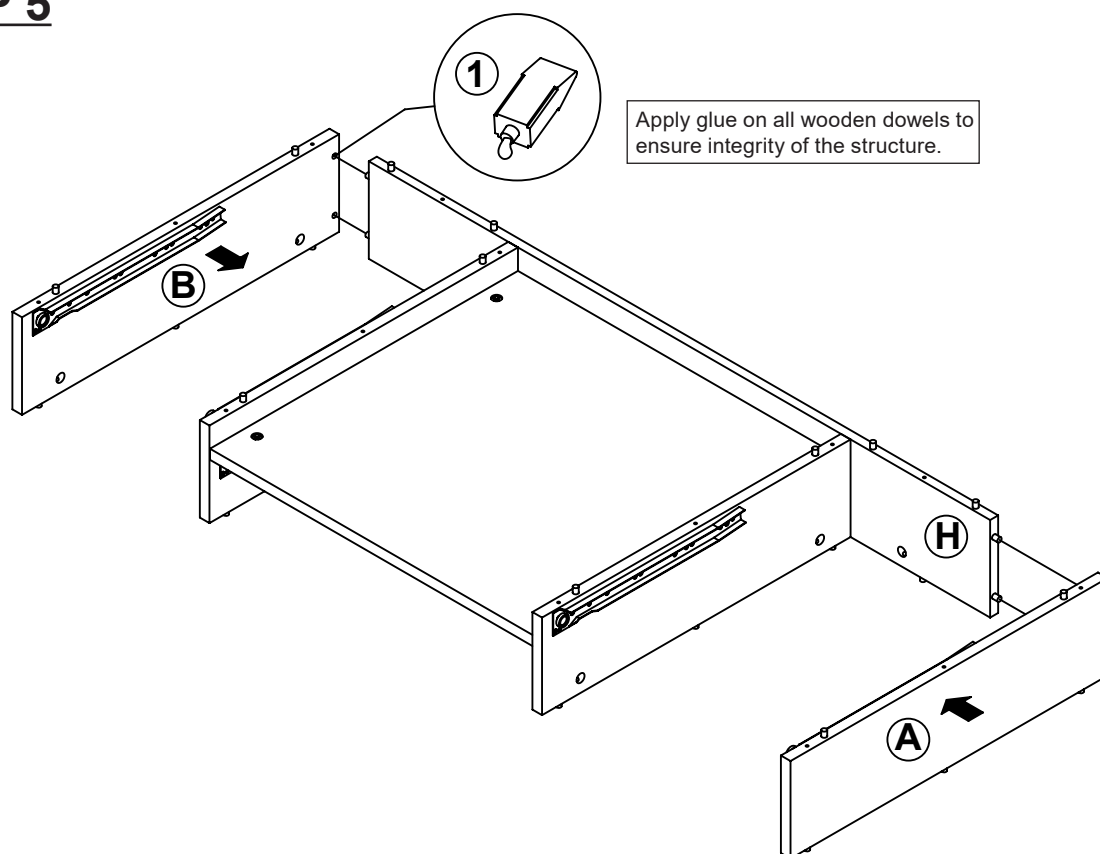

Apply glue on all wooden dowels to ensure integrity of the structure.

ITEM: 802001

**COASTER**  
FINE FURNITURE

**STEP 6**

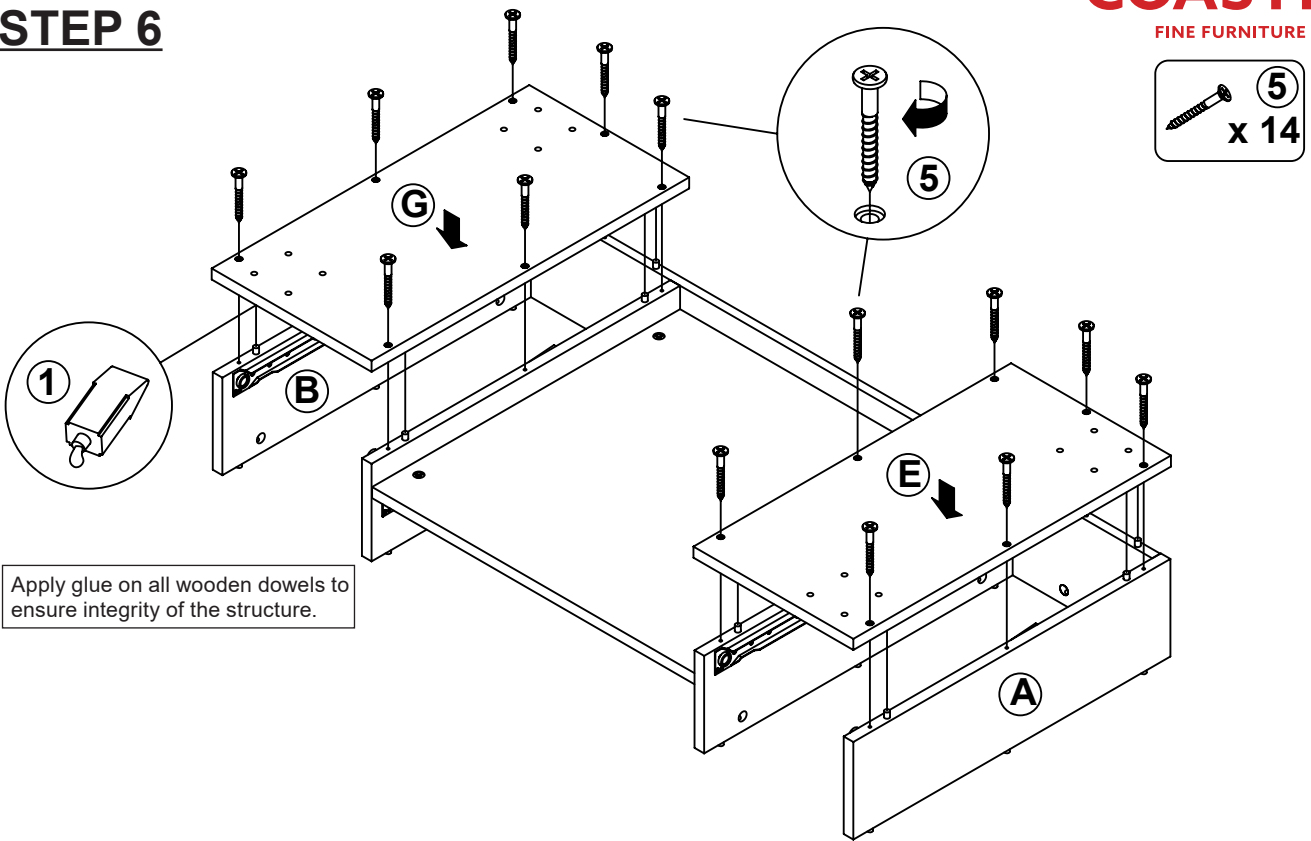

**STEP 7**

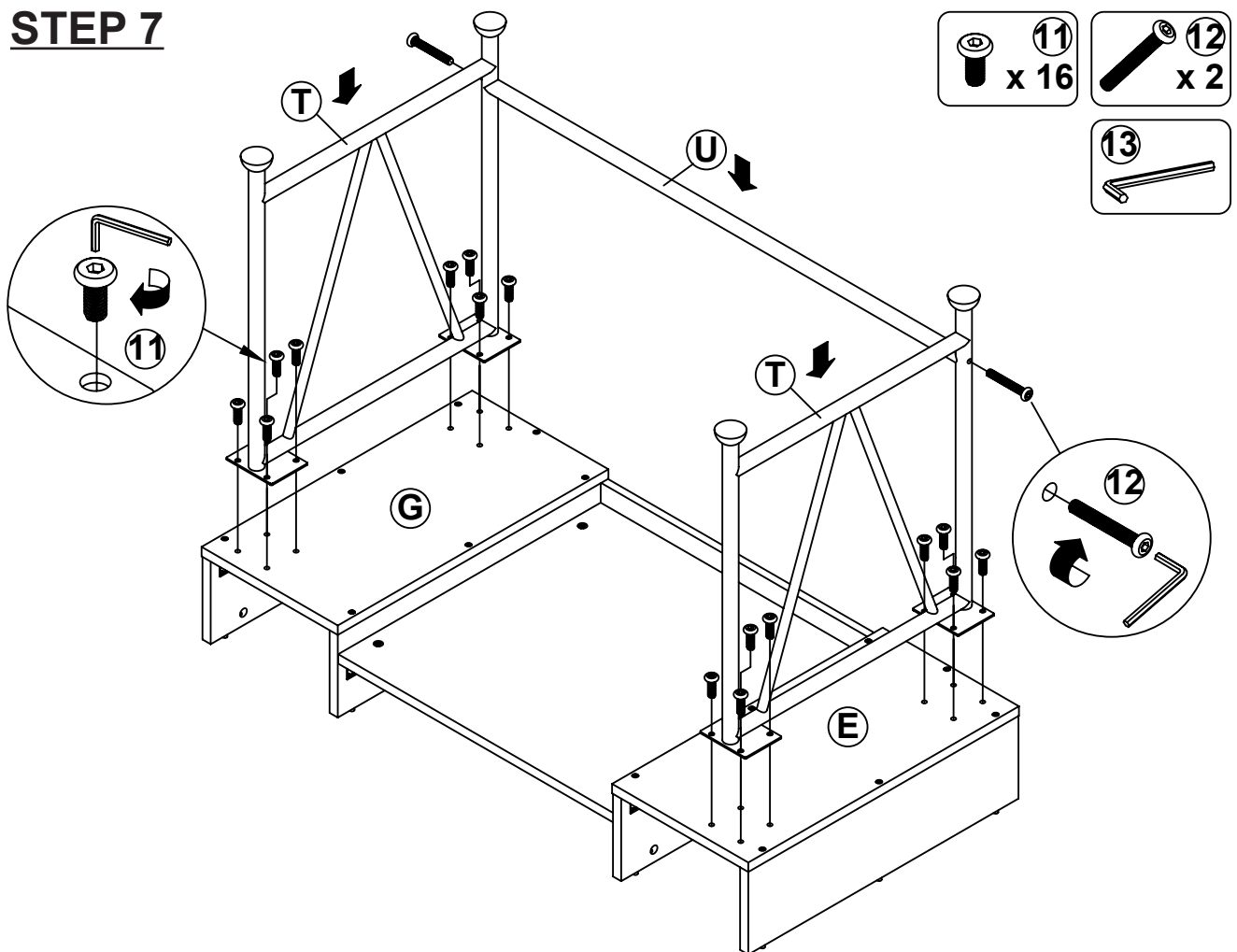

ITEM: 802001

**STEP 8**

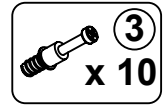
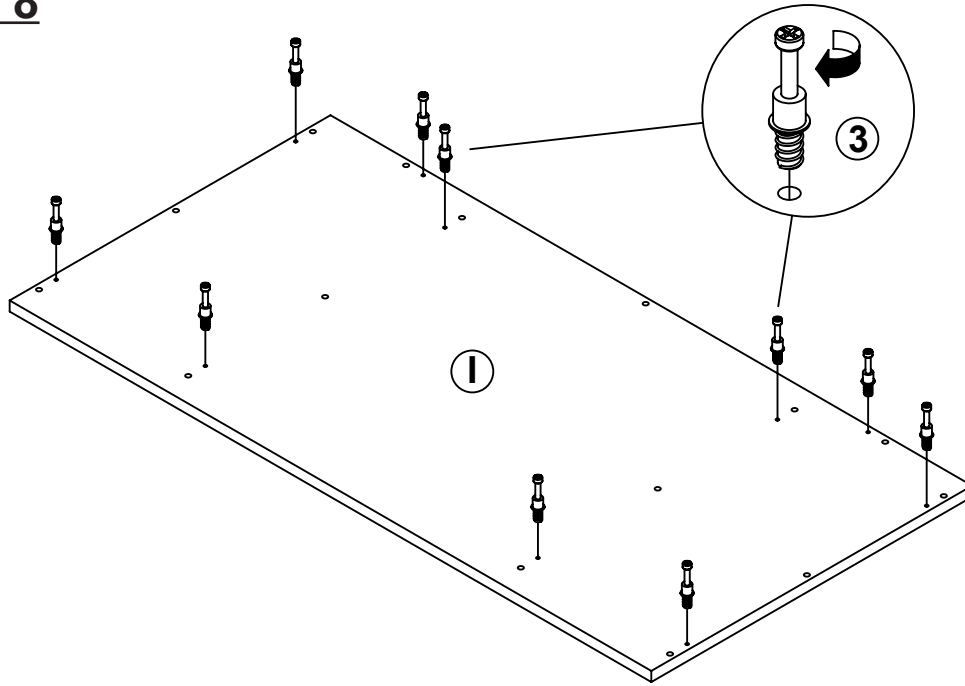

**STEP 9**

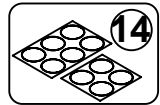
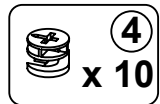

Apply glue on all wooden dowels to ensure integrity of the structure.

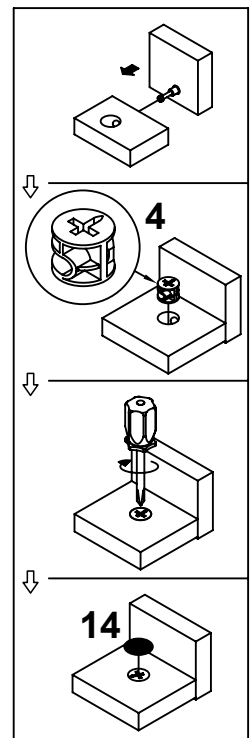
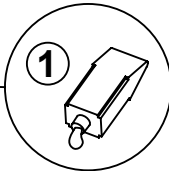
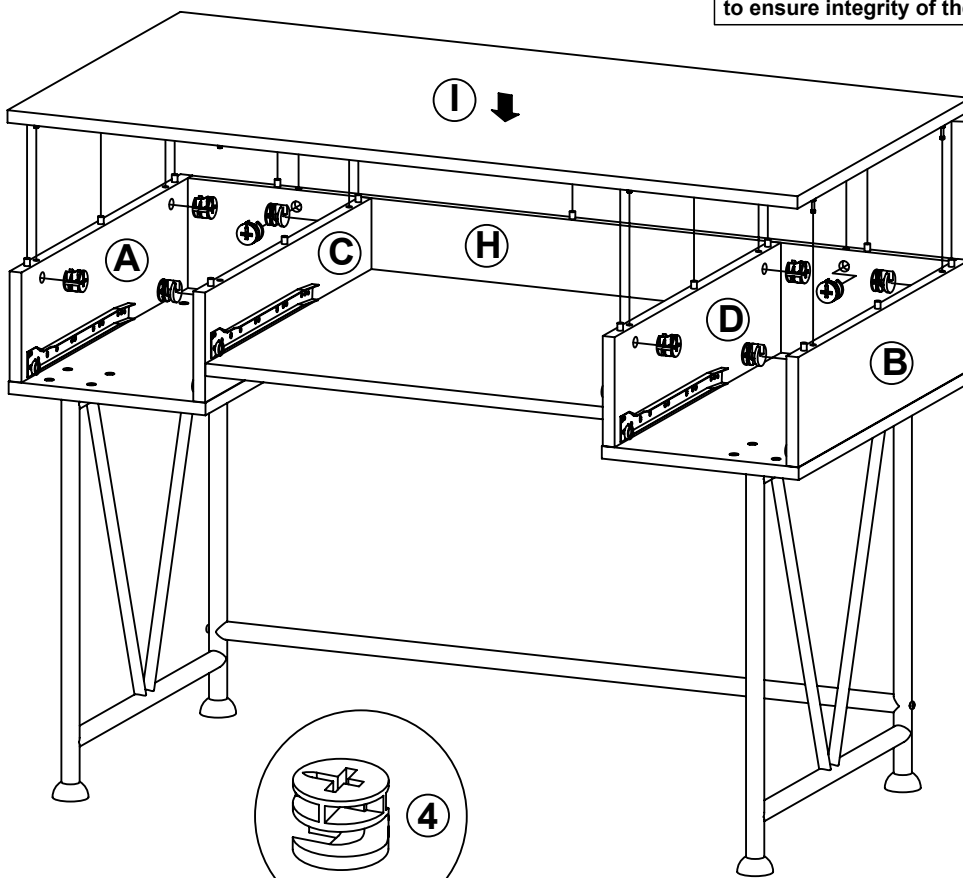

ITEM: 802001

**STEP 10-1**

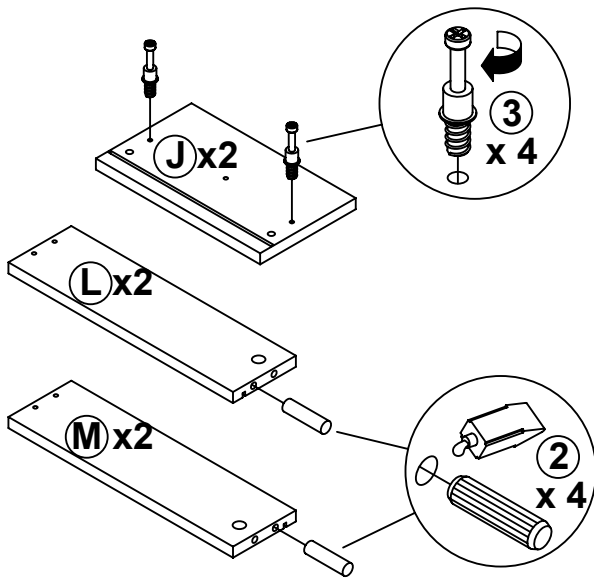

**STEP 10-2**

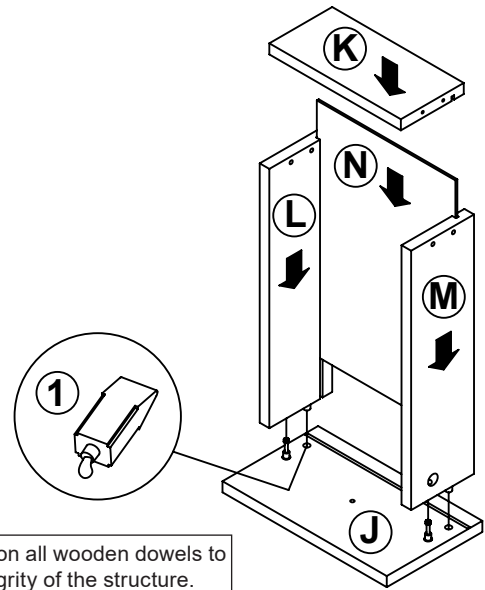

**STEP 10-3**

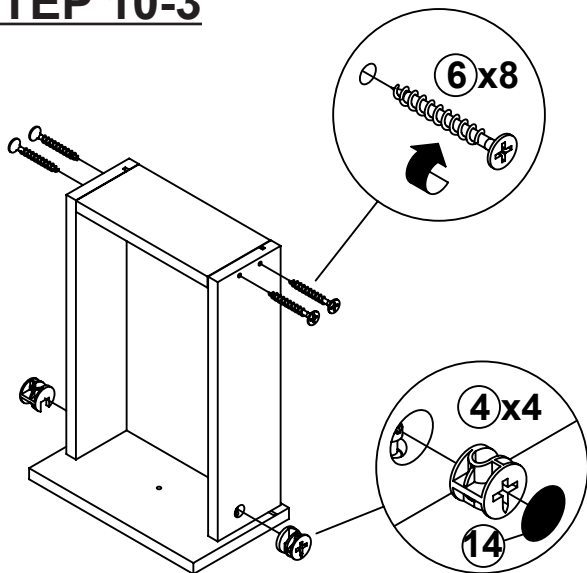

**STEP 10-4**

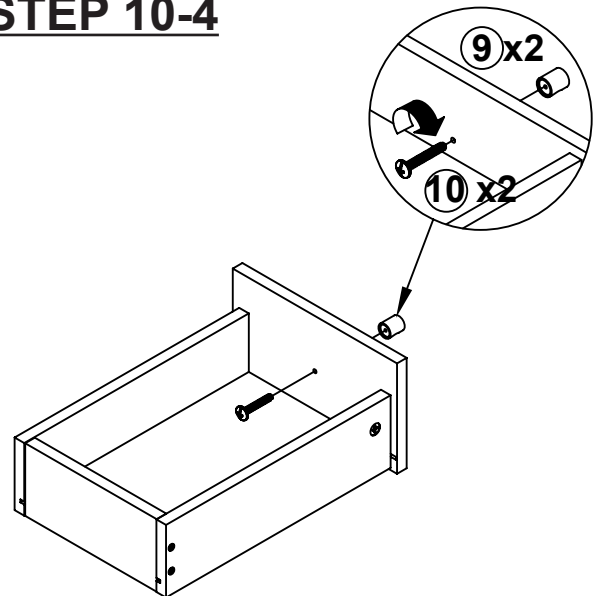

**STEP 10-5**

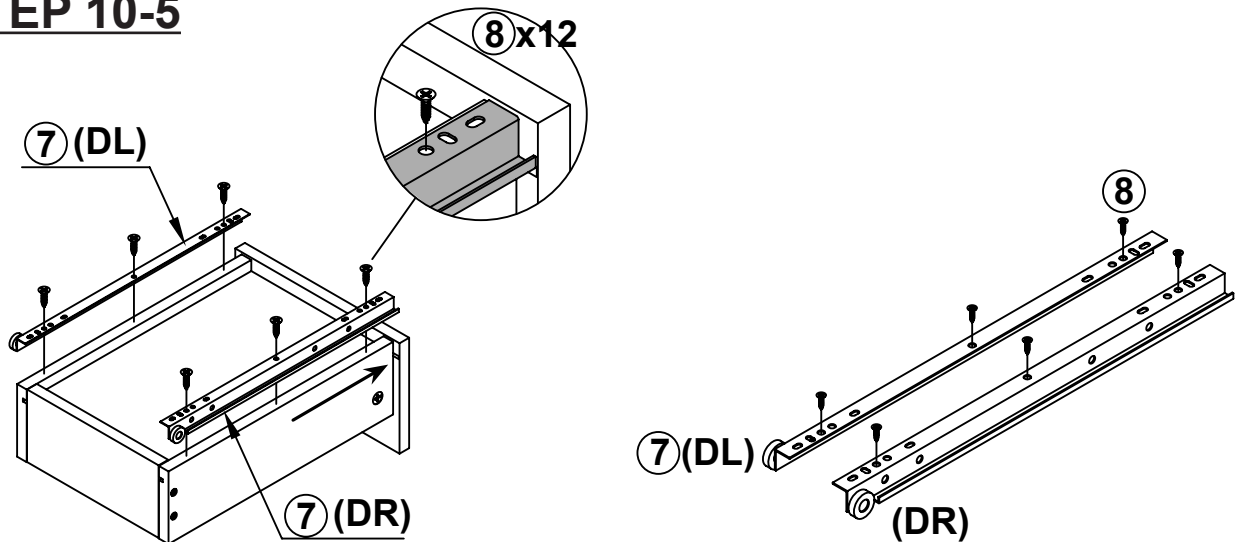

ITEM: 802001

**STEP 11-1**

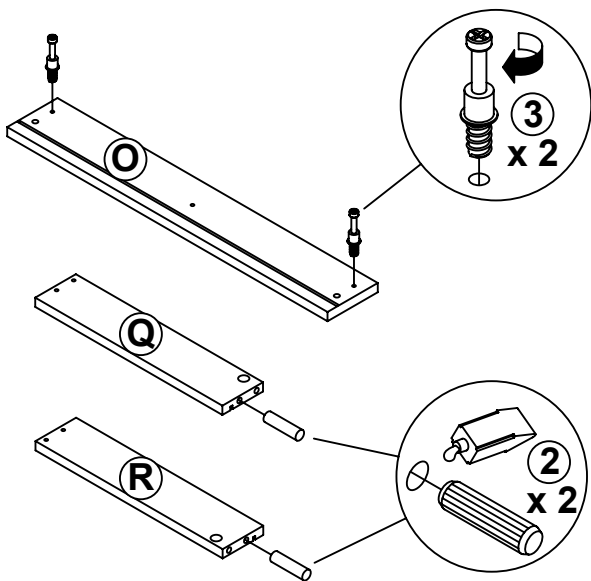

**STEP 11-2**

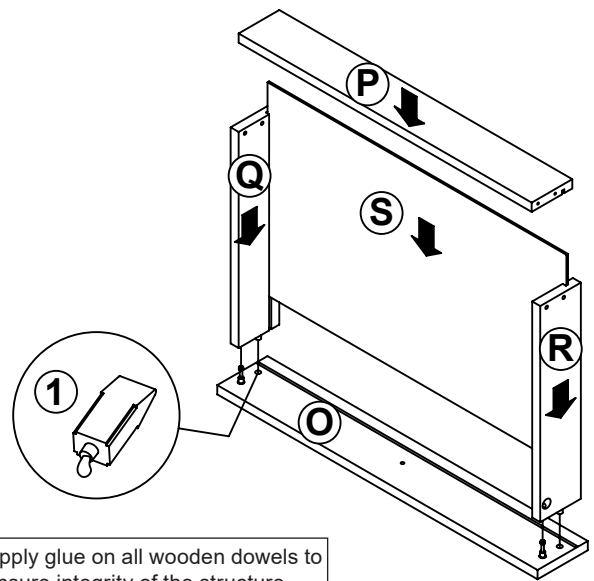

Apply glue on all wooden dowels to ensure integrity of the structure.

**STEP 11-3**

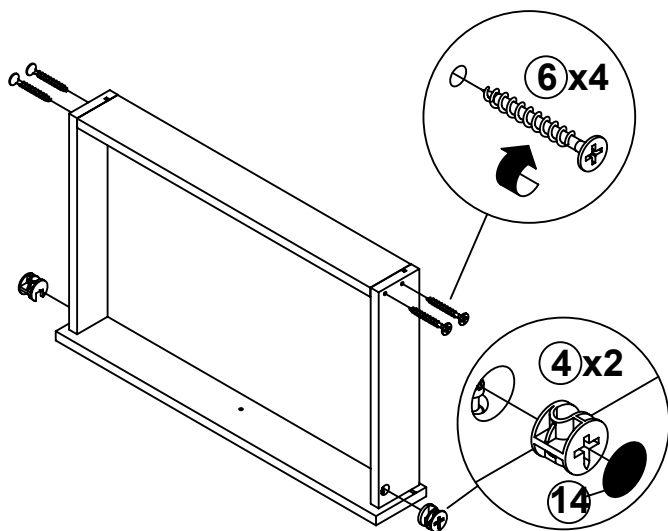

**STEP 11-4**

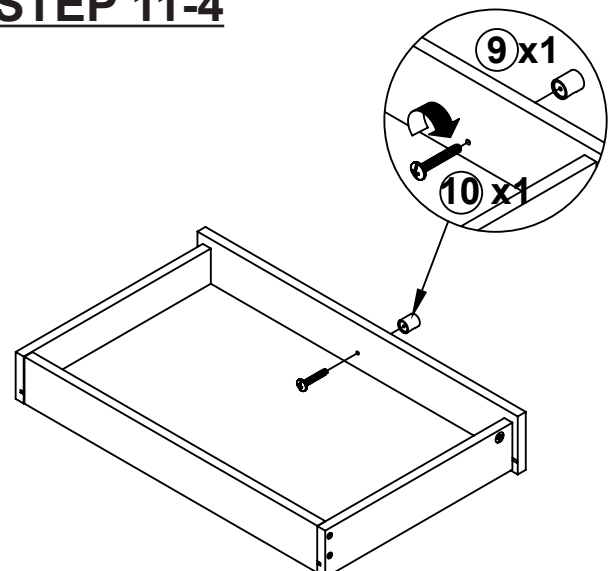

**STEP 11-5**

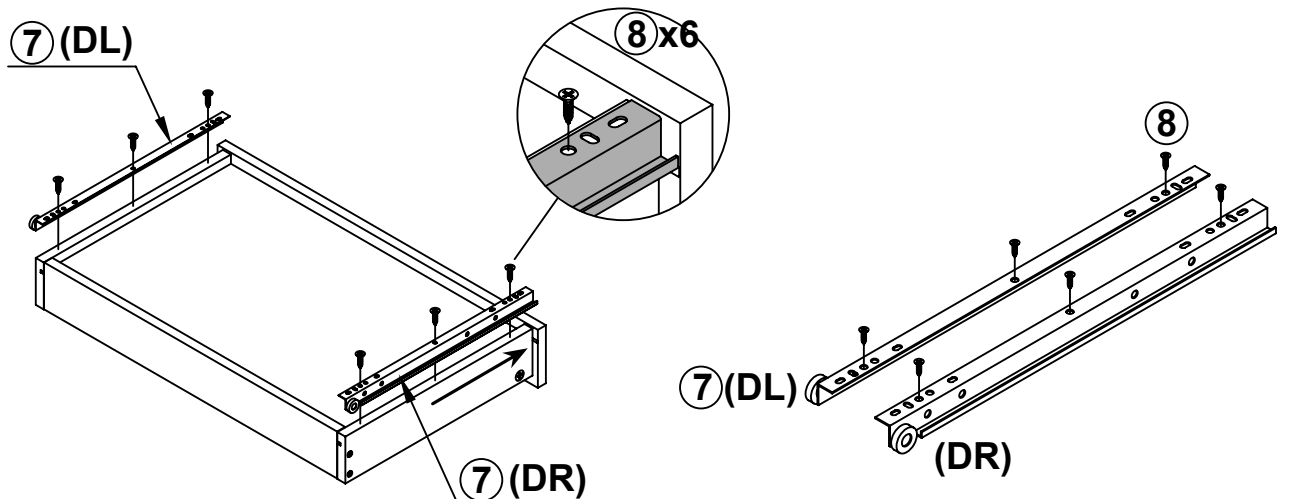

ITEM: 802001

**STEP 12**

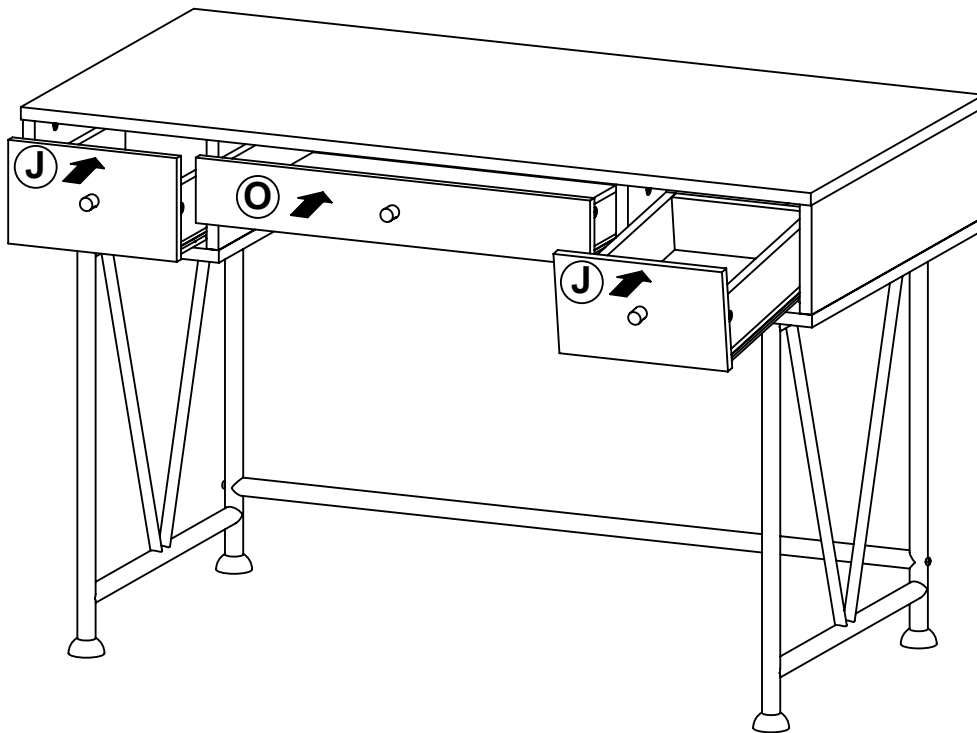

**STEP 13**  
**COMPLETE**

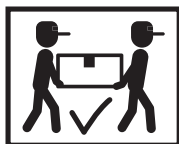
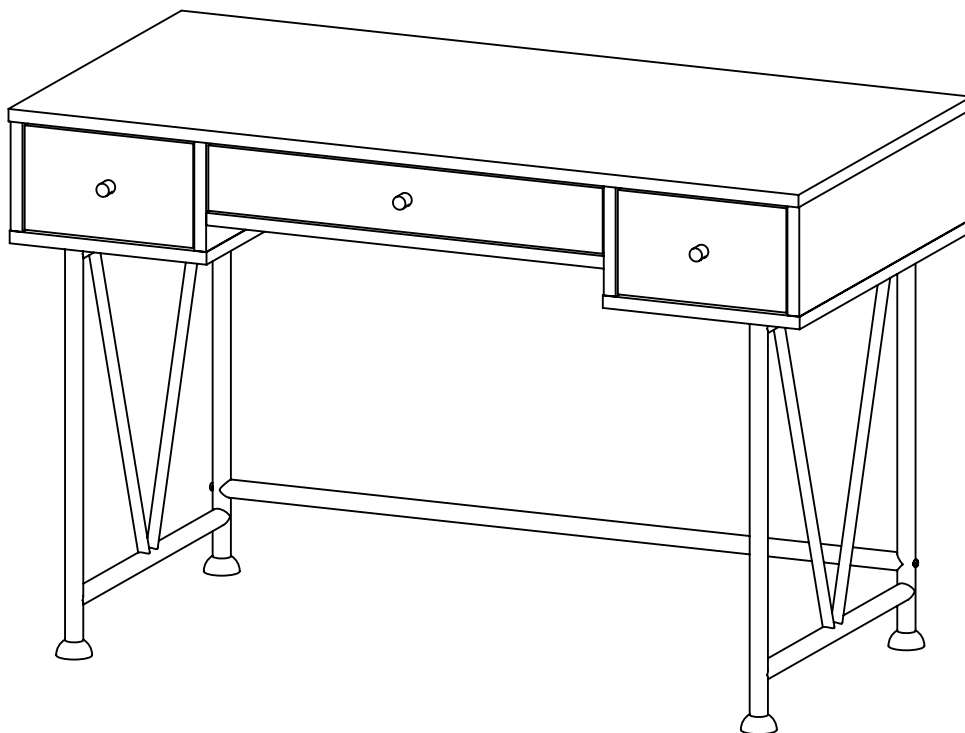

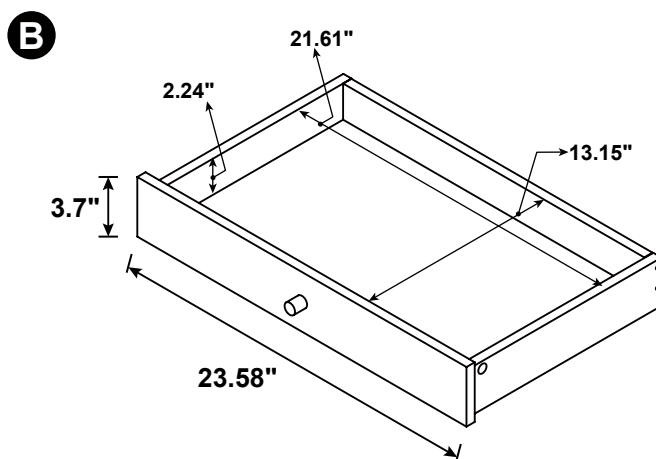
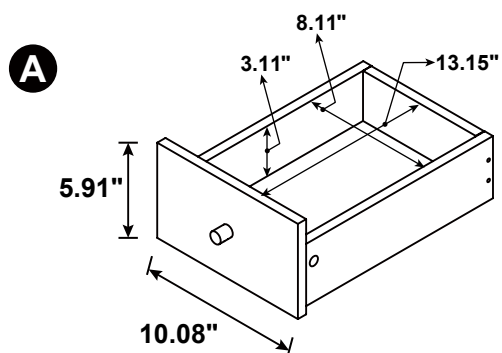
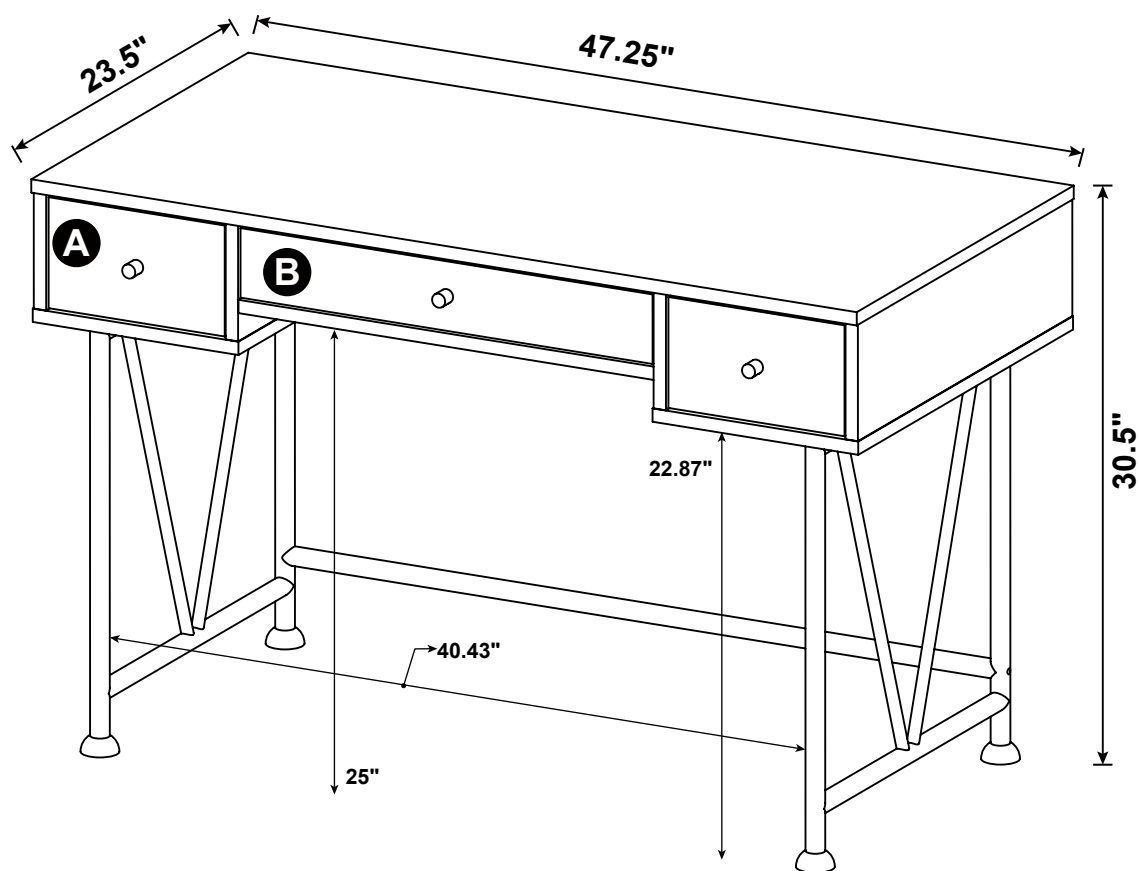

Note : Dimension tolerance  $\pm 5\%$