

*ASSEMBLY INSTRUCTIONS
COASTER FINE FURNITURE*



Fine Furniture for every stage of life

930302
SIDE TABLE

ITEM:930302

ASSEMBLY INSTRUCTIONS

ASSEMBLY TIPS:

1. Remove hardware from box and sort by size.
2. Please check to see that all hardware and parts are present prior to start of assembly.
3. Please follow attached instructions in the same sequence as numbered to assure fast & easy assembly.



WARNING!

1. Don't attempt to repair or modify parts that are broken or defective. Please contact the store immediately.
2. This product is for home use only and not intended for commercial establishments.



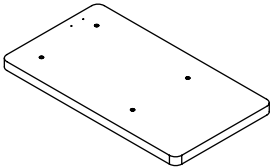
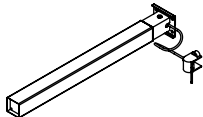
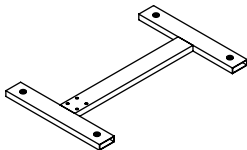
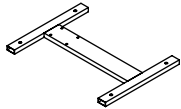

ASSEMBLY TIME

30 MINUTES

PARTS IDENTIFICATION

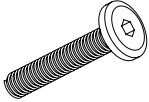
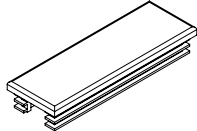
A	TOP		1 PC	C	LIFTING POLE		1 PC
B	BASE FRAME		1 PC	D	TOP FRAME		1 PC

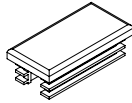
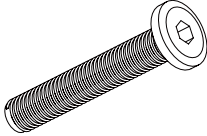
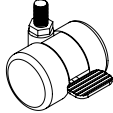
HARDWARE IDENTIFICATION

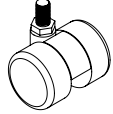
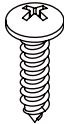
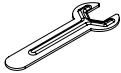
Z							
NO	DESCRIPTION	FIGURE	Q'TY	NO	DESCRIPTION	FIGURE	Q'TY
1	BOLT M6x33mm BLK		4 PCS	6	FLOOR PROTECTOR 60x20mm		4 PCS
2	BOLT M6x15mm BLK		4 PCS	7	FLOOR PROTECTOR 30x15mm		4 PCS
3	BOLT M6x43mm BLK		4 PCS	8	LOCKING CASTER		2 PCS
4	ALLEN WRENCH 4mm SR		1 PC	9	CASTER		2 PCS
5	SCREW Ø5x23mm BLK		2 PCS	10	SPANNER		1 PC

Z8,Z9,Z10 not included in blister packaging.

NOTE:

Phillips head screw driver is required in the assembly process; however, manufacturer does not provide this item.

ITEM: 930302

COASTER[®]

FINE FURNITURE

STEP 1

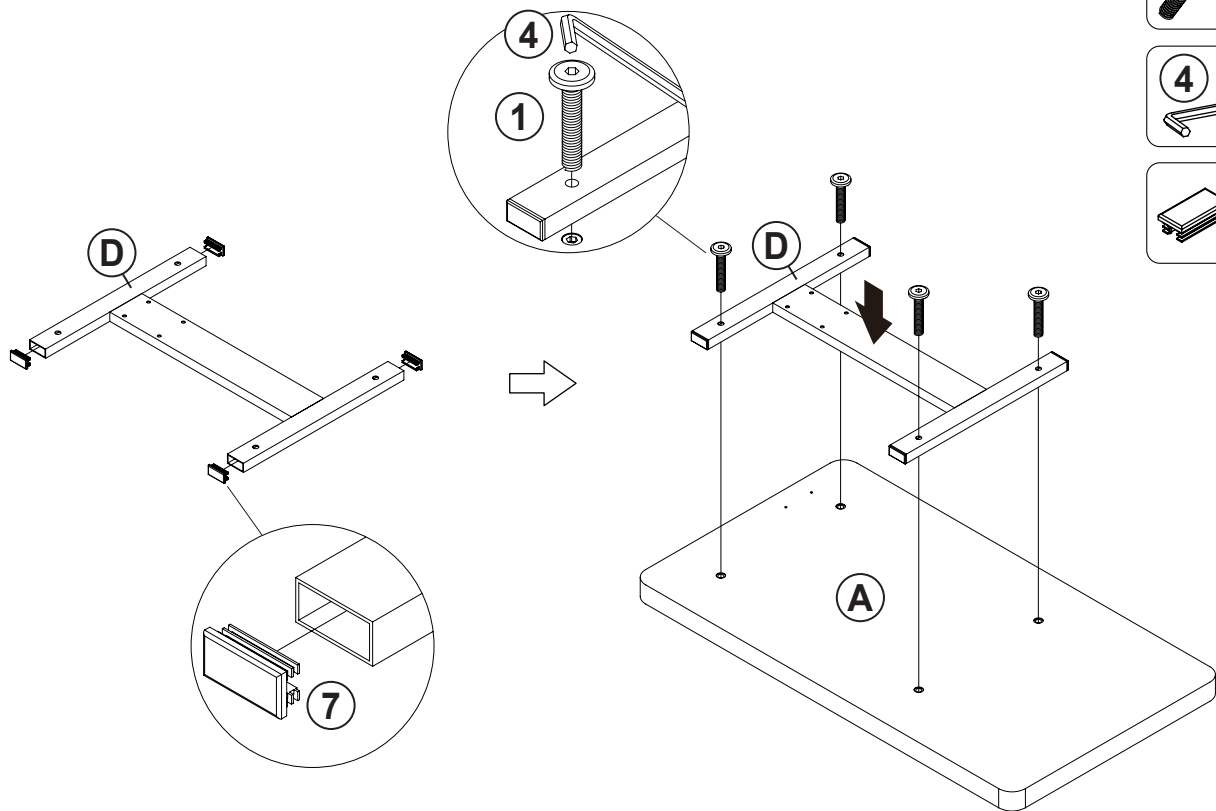

STEP 2

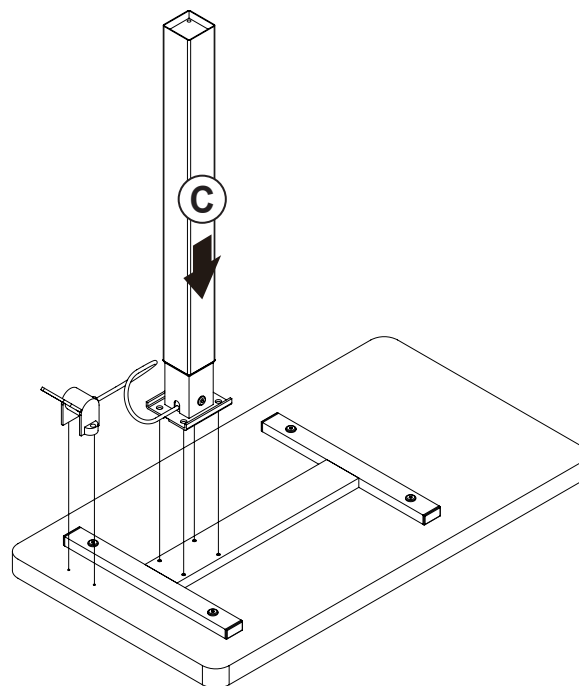

ITEM: **930302**

COASTER[®]

FINE FURNITURE

STEP 3

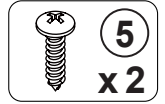
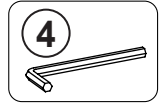
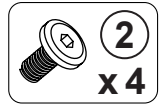
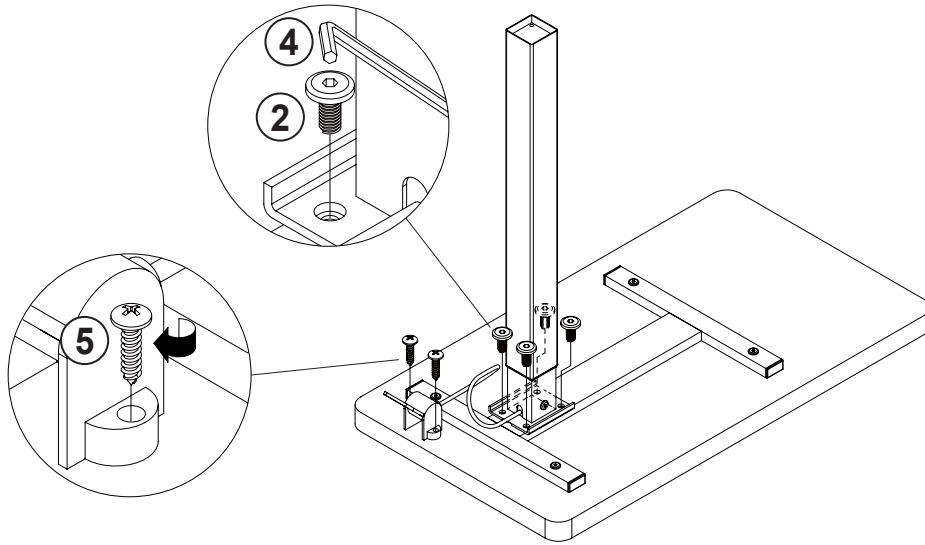

STEP 4

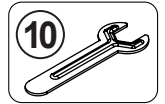
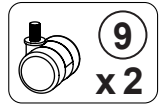
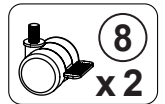
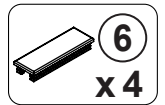
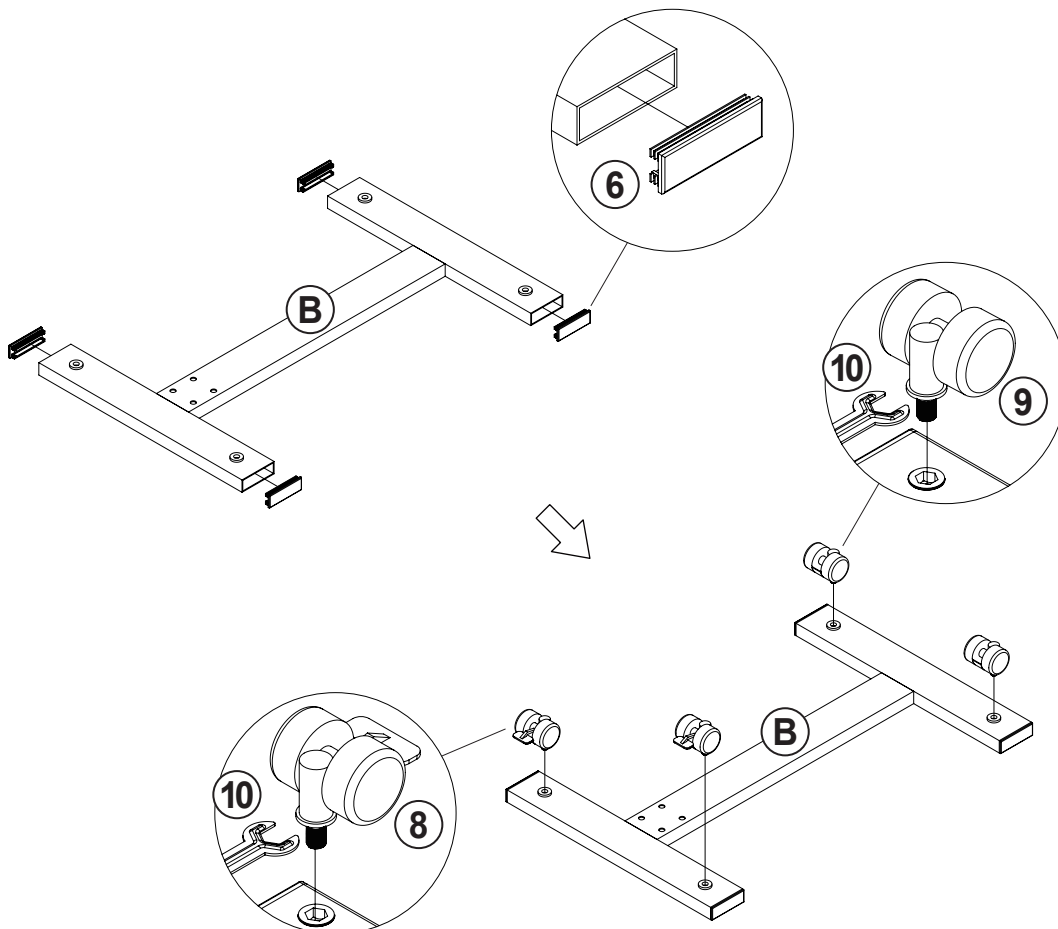

ITEM: **930302**

COASTER[®]

FINE FURNITURE

STEP 5

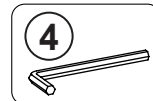
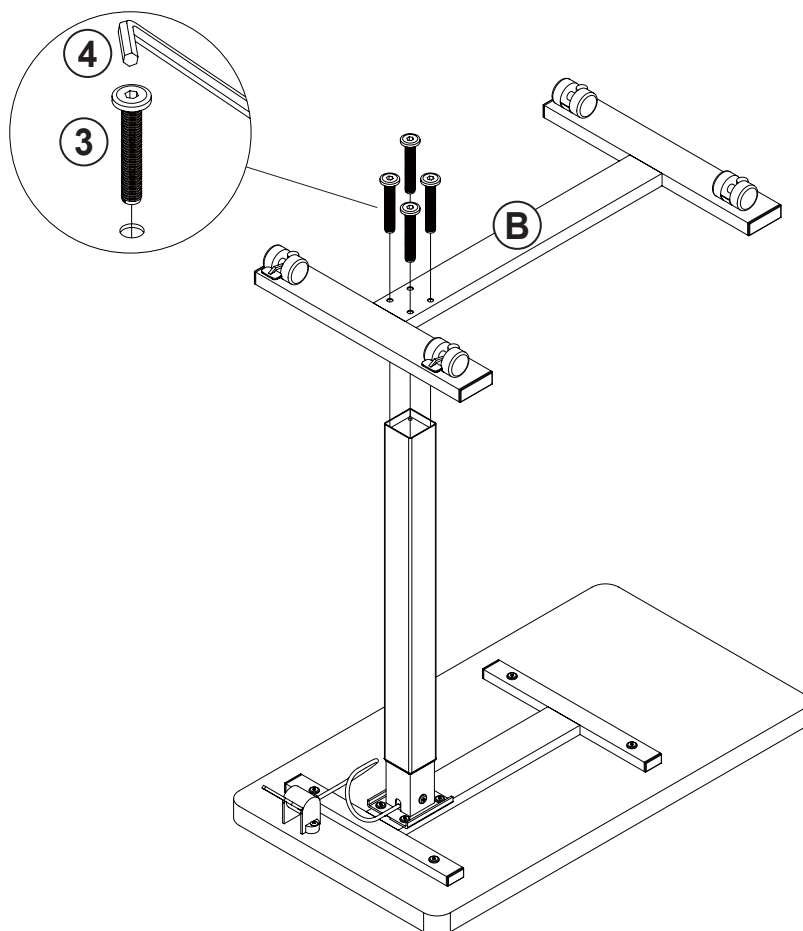

STEP 6

COMPLETE

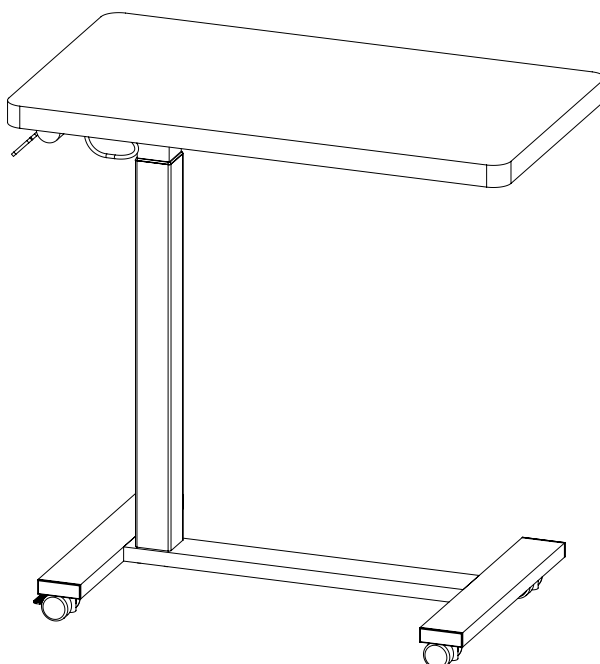

ITEM: **930302**

STEP 7

HANDLE USE MANUAL

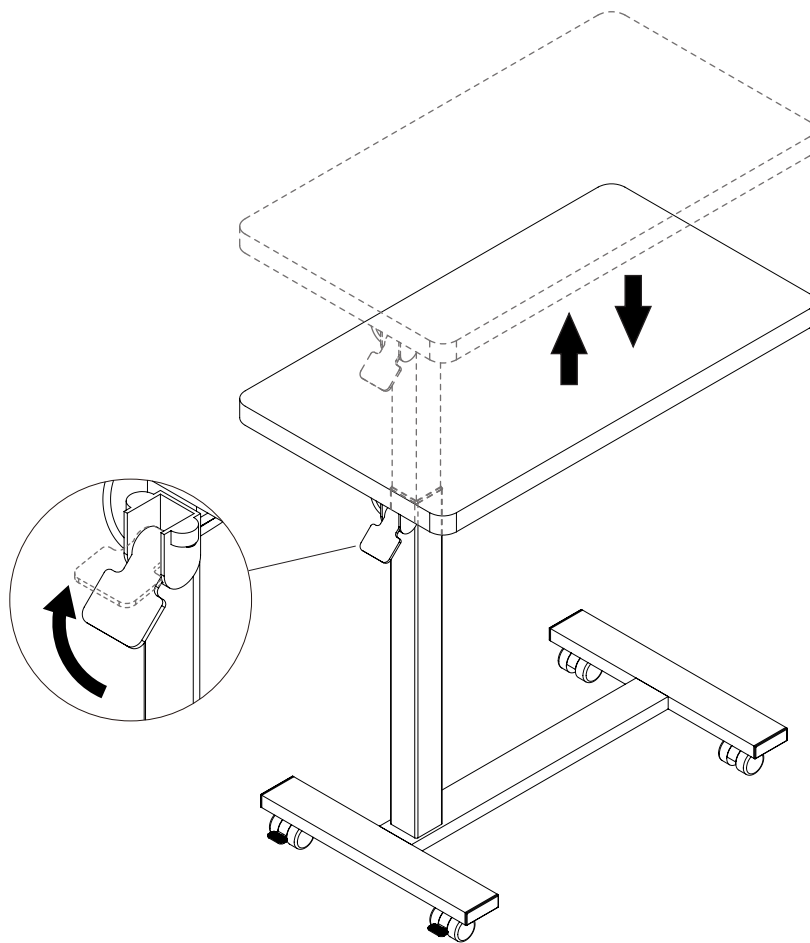

ITEM:930302

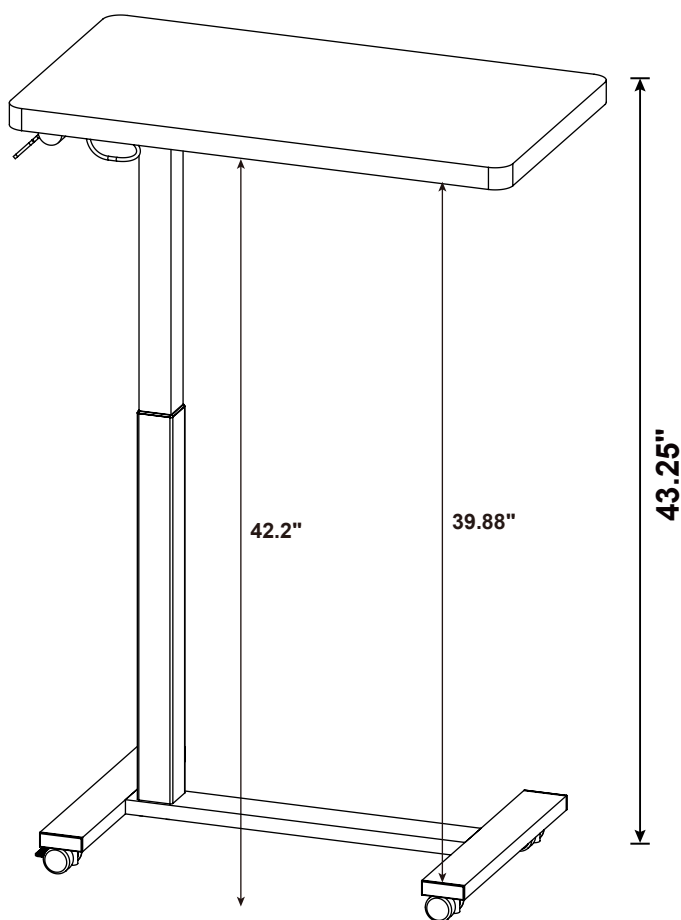
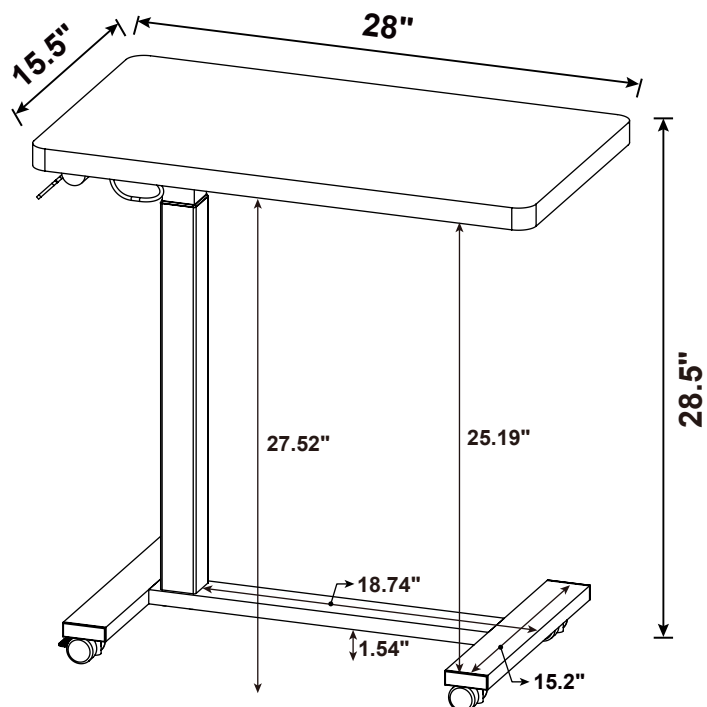

Note : Dimension tolerance $\pm 5\%$