

ASSEMBLY INSTRUCTIONS
COASTER FINE FURNITURE



Fine Furniture for every stage of life

910224
SHOE BENCH

ITEM:910224



ASSEMBLY INSTRUCTIONS

ASSEMBLY TIPS:

1. Remove hardware from box and sort by size.
2. Please check to see that all hardware and parts are present prior to start of assembly.
3. Please follow attached instructions in the same sequence as numbered to assure fast & easy assembly.



WARNING!

1. Don't attempt to repair or modify parts that are broken or defective. Please contact the store immediately.
2. This product is for home use only and not intended for commercial establishments.

ASSEMBLY TIME 60 MINUTES

PARTS IDENTIFICATION

A

TOP PANEL

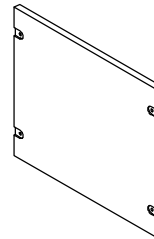

1PC

B

LEFT PANEL

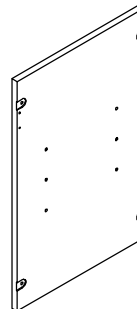

1PC

C

RIGHT PANEL



1PC

D

BACK PANEL

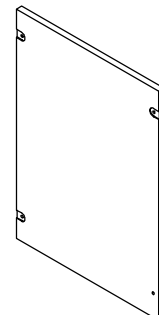

1PC

ITEM:910224

ASSEMBLY INSTRUCTIONS

PARTS IDENTIFICATION



E BOTTOM PANEL

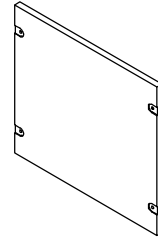

1PC

F SHELF PANEL

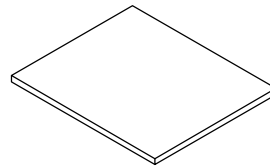

1PC

G DOOR PANEL

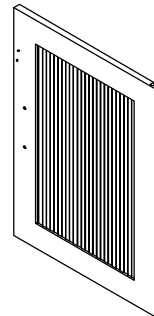

1PC

H CUSHION

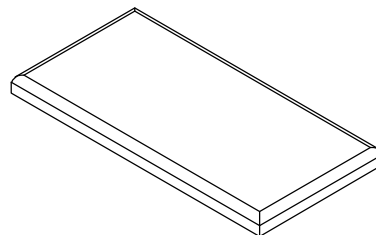

1PC

I FRONT FRAME

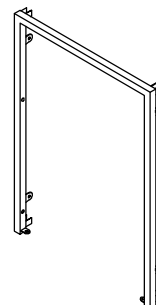

1PC

ITEM:910224

ASSEMBLY INSTRUCTIONS

PARTS IDENTIFICATION



J BACK FRAME

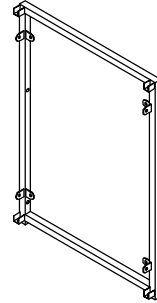

1PC

K LEFT FRAME

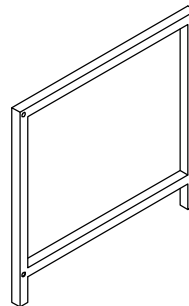

1PC

L BOTTOM FRAME

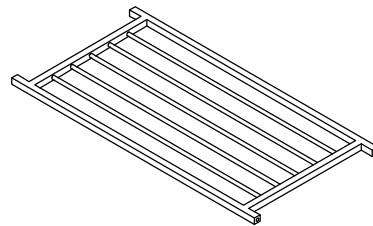

1PC

M BOTTOM CROSSBAR

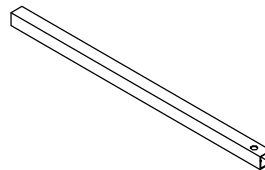

1PC

N SHORT CROSSBAR

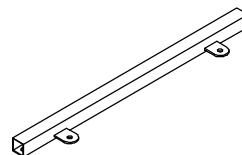

4PCS

ITEM:910224



ASSEMBLY INSTRUCTIONS

PARTS IDENTIFICATION

O

LONG CROSSBAR

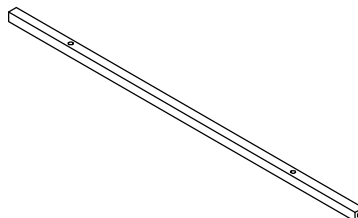

2PCS

P

HANDLE

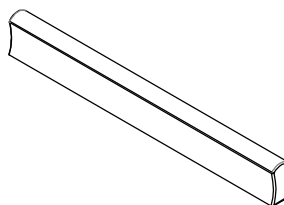

1PC







ITEM:910224





ASSEMBLY INSTRUCTIONS

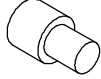

Z

HARDWARE IDENTIFICATION

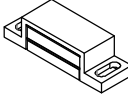
1	SMALL BOLT (1/4" x12mm)		10PCS
2	SMALL BOLT (1/4" x28mm)		4PCS
3	LONG BOLT (1/4" x 45mm)		8PCS
4	SMALL SCREW (6 x 12mm)		1PC
5	SHORT SCREW (3.5 x 9 mm)		22PCS
6	SMALL LONG BOLT (5/32" x22mm)		2PCS
7	CAP (18 x 18mm)		6PCS

8	HINGE INSERT		2PCS
9	SHELF PIN		4PCS
10	METAL		1PC
11	DOOR PIN		2PCS
12	PLASTIC MAGNET		1PC
13	ALLEN WRENCH (4mm)		1PC

ITEM:910224

ASSEMBLY INSTRUCTIONS



STEP 1 Do not tighten until each step is completed or instructed.

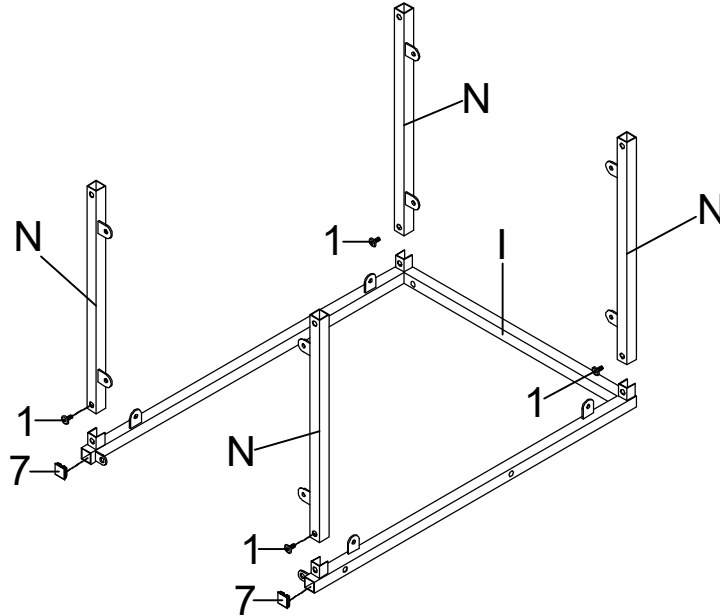

STEP 2

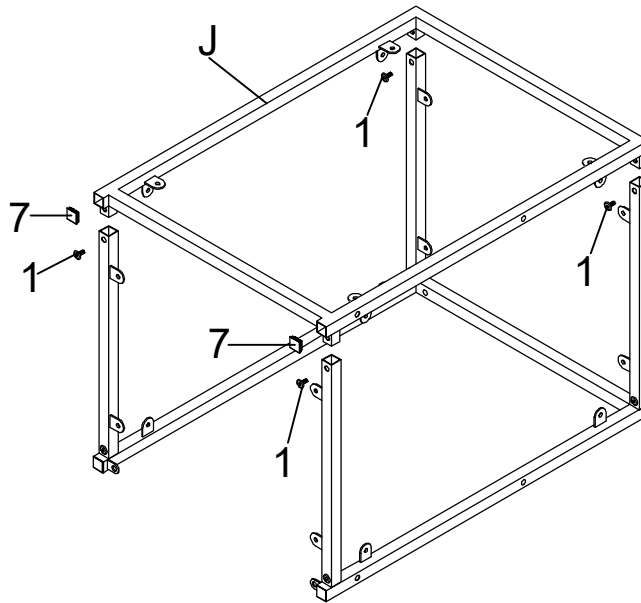

ITEM:910224
ASSEMBLY INSTRUCTIONS
STEP 3

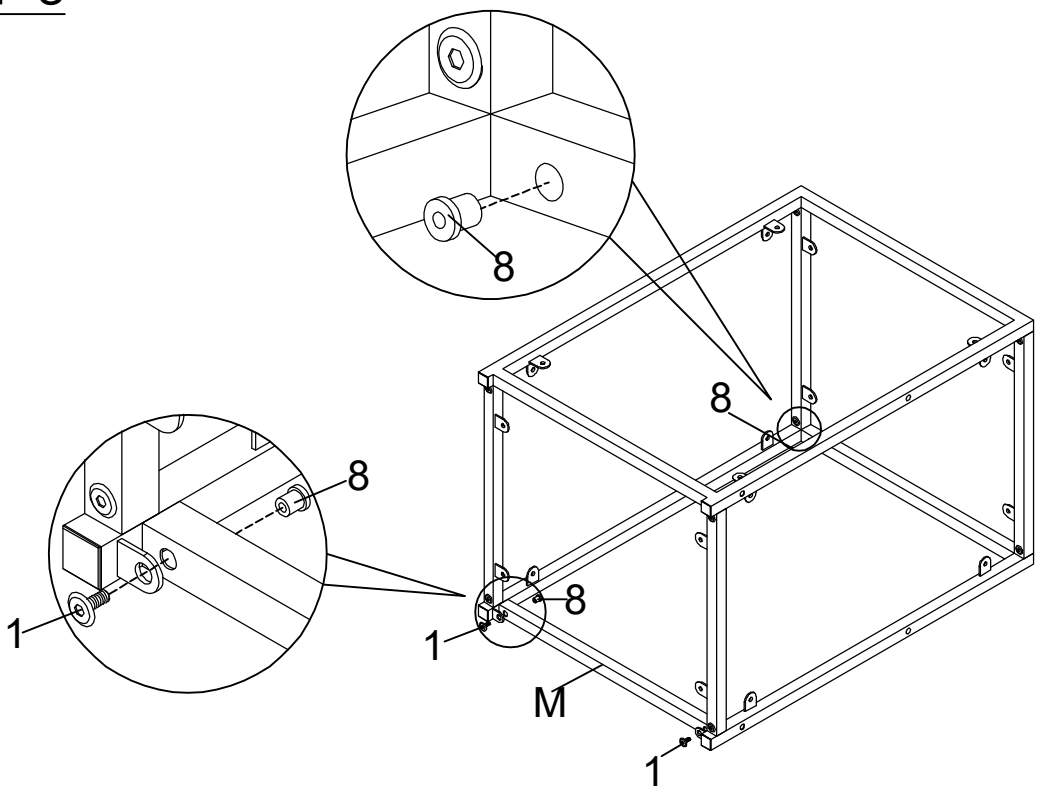

STEP 4

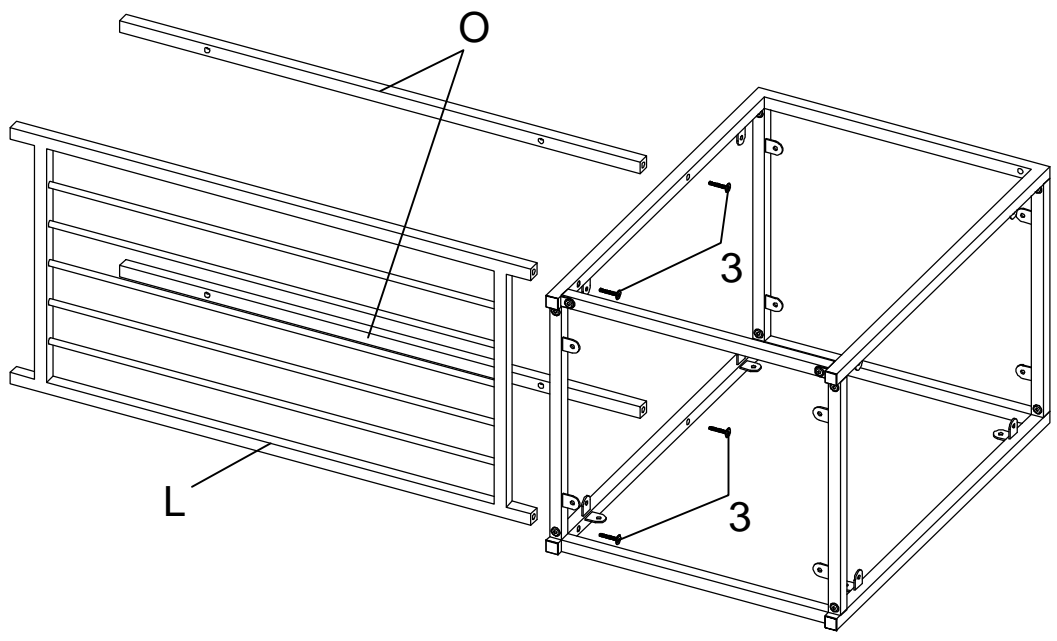

ITEM:910224
ASSEMBLY INSTRUCTIONS



STEP 5

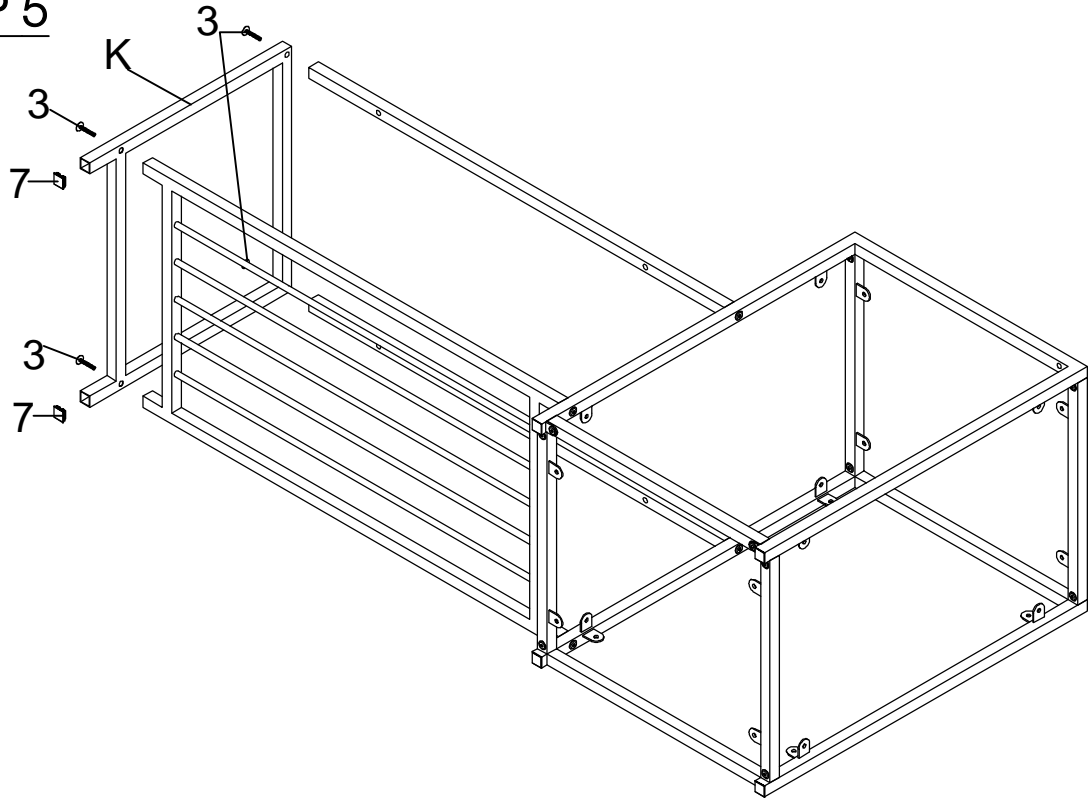

STEP 6

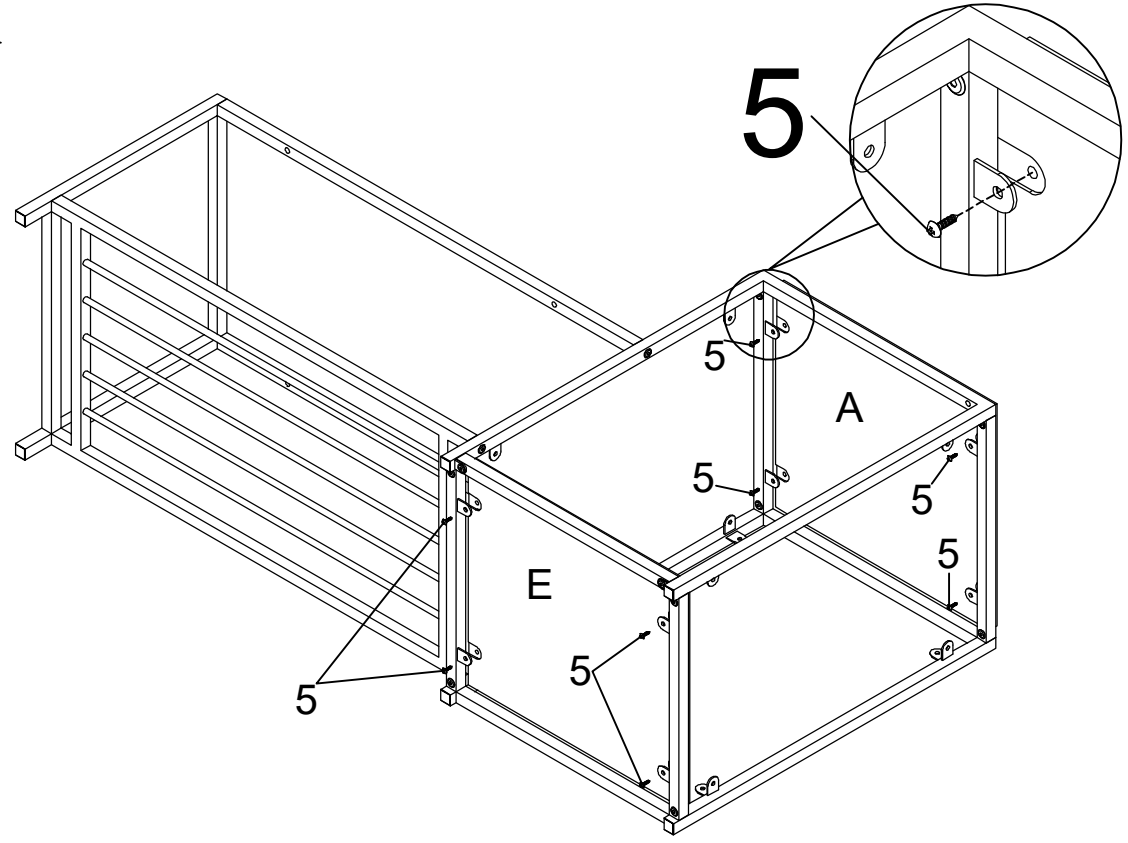

ITEM:910224
ASSEMBLY INSTRUCTIONS
STEP 7

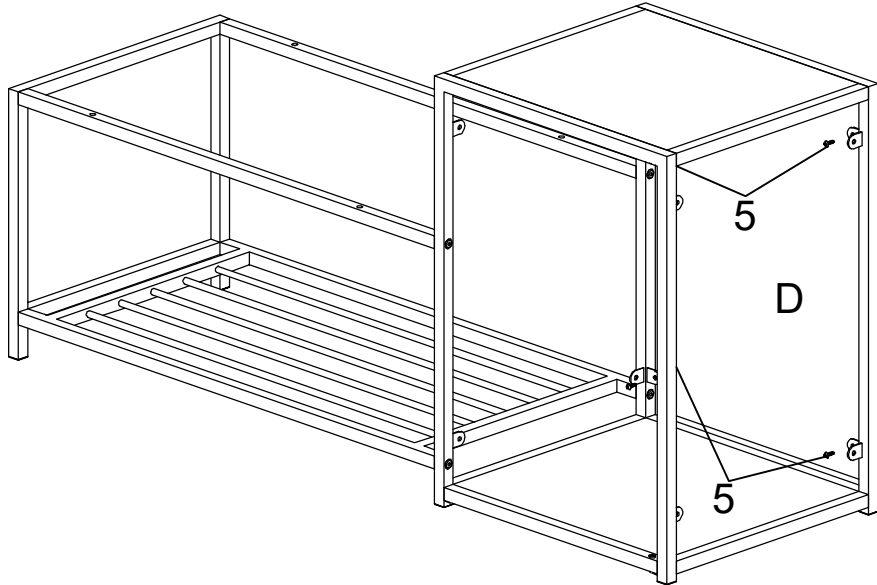

STEP 8

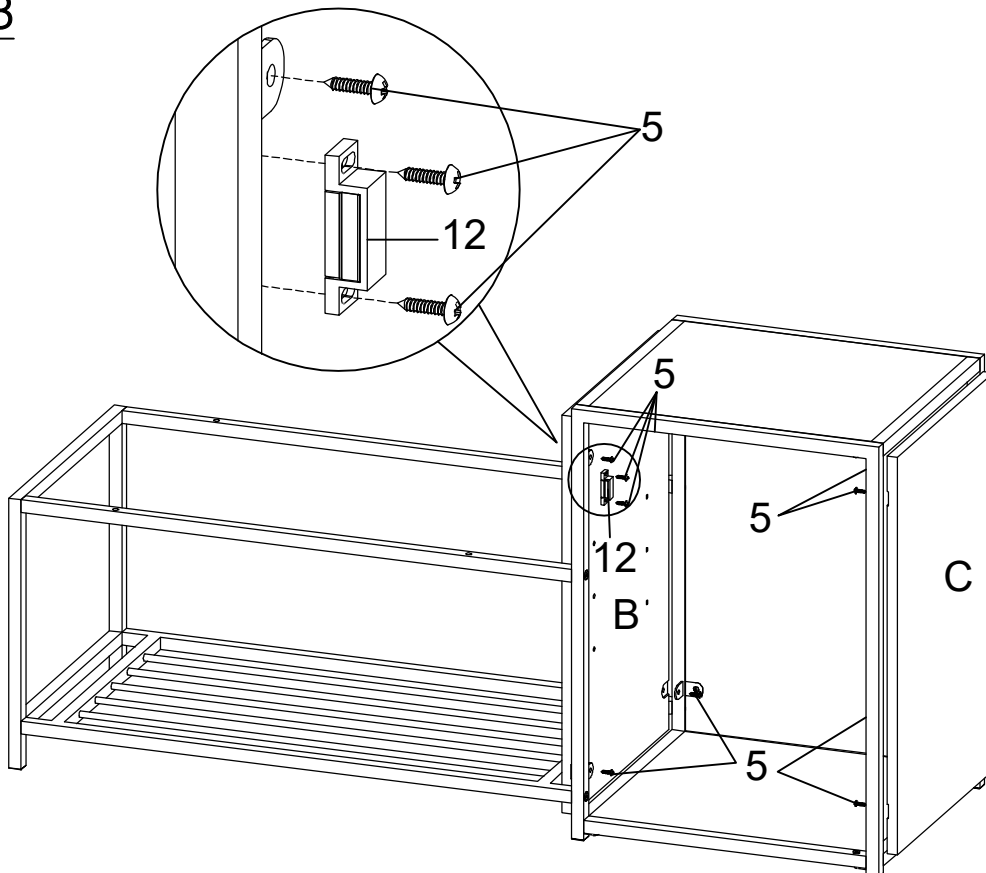

ITEM:910224
ASSEMBLY INSTRUCTIONS
STEP 9

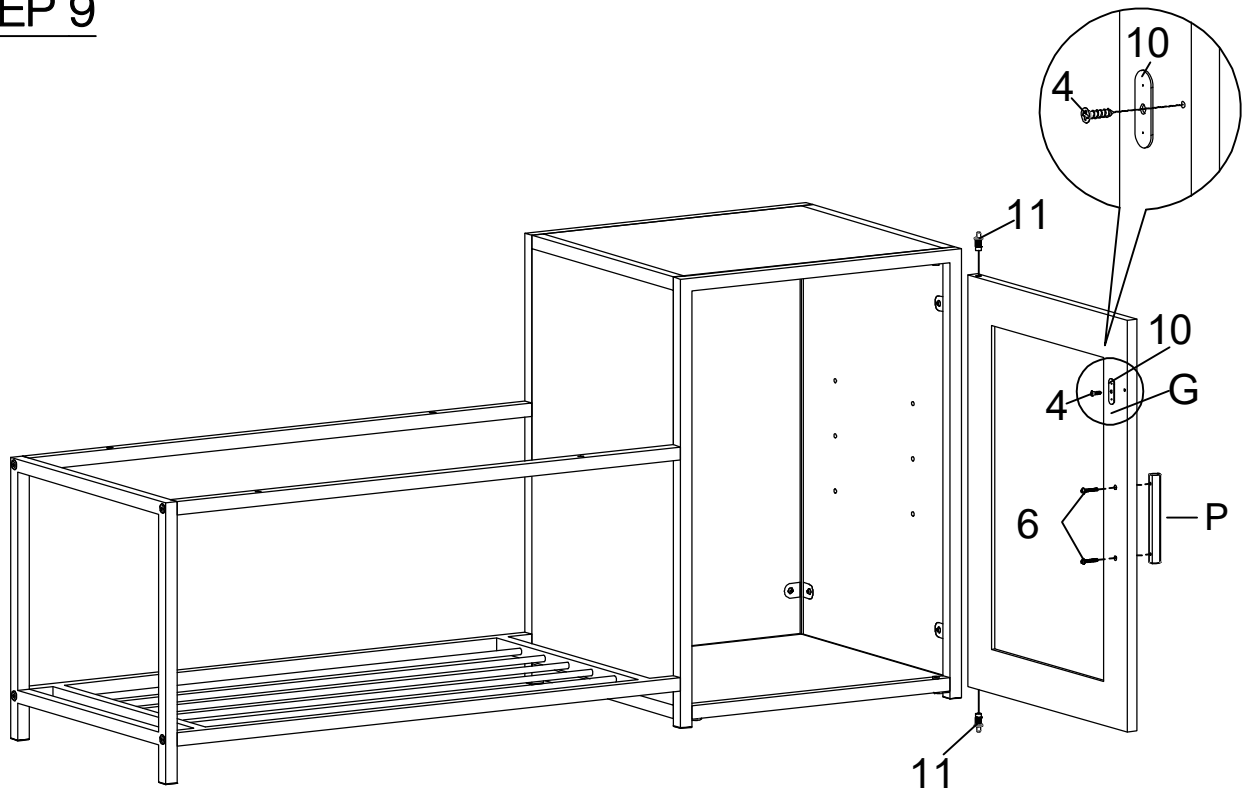

STEP 10

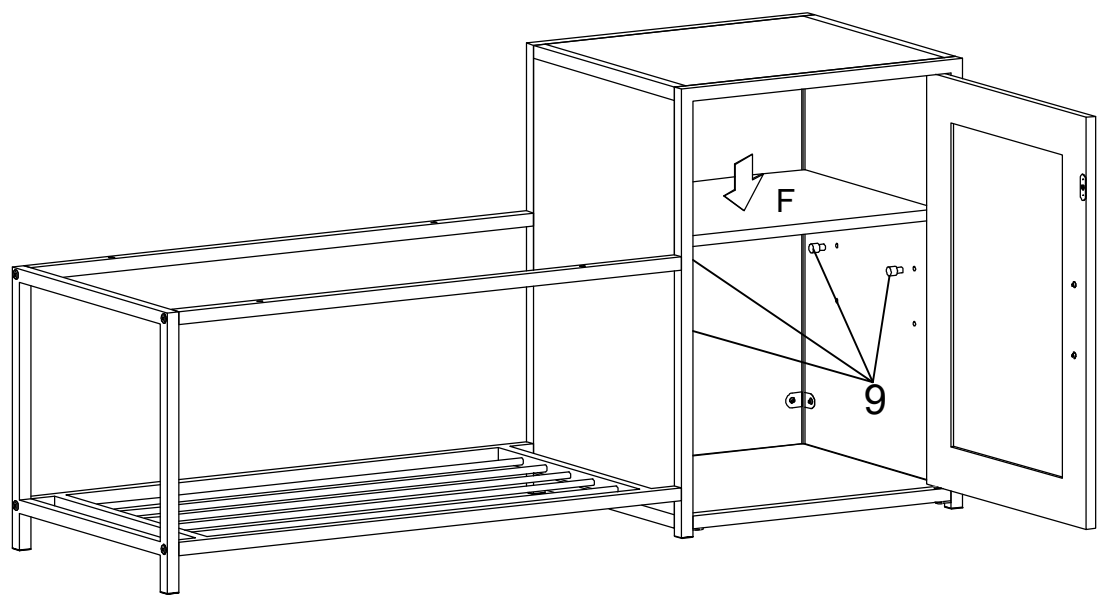

ITEM:910224
ASSEMBLY INSTRUCTIONS
STEP 11

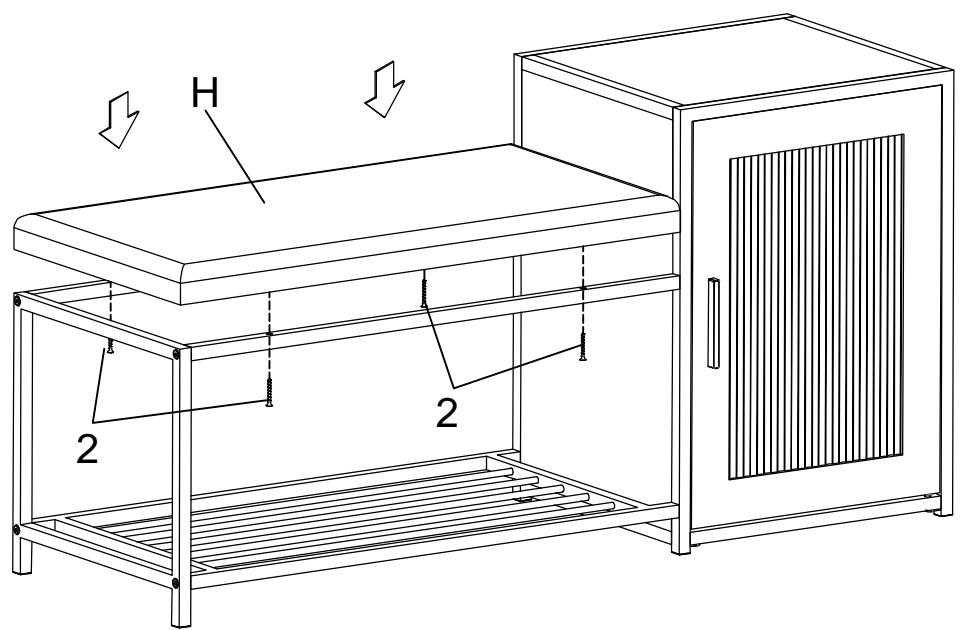

STEP 12
COMPLETE

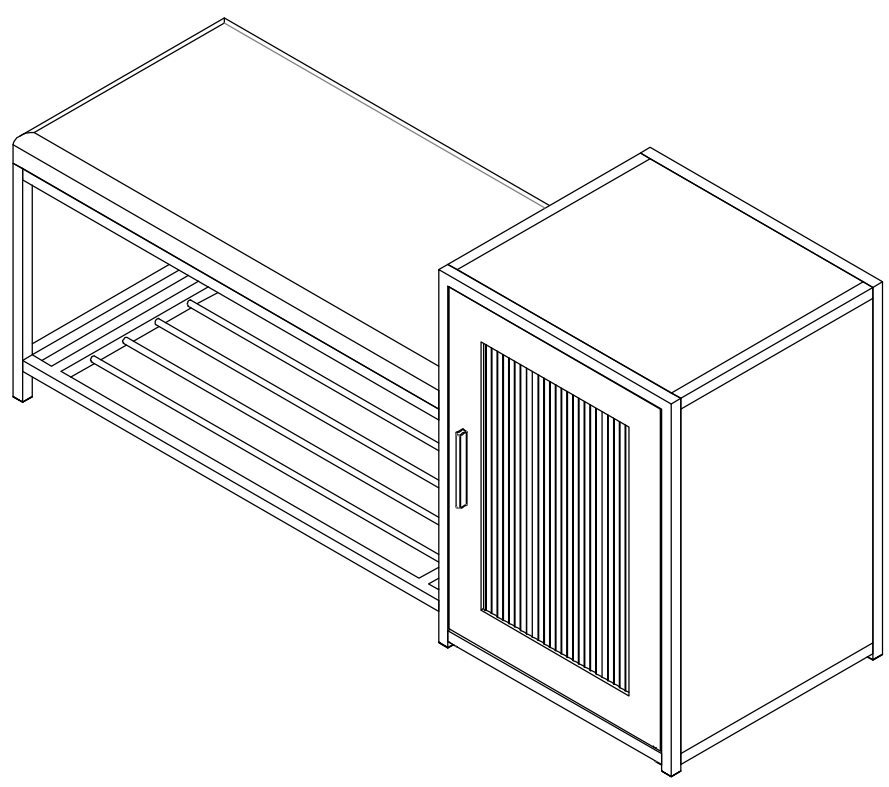

ITEM:910224 ASSEMBLY INSTRUCTIONS



Product Size : 1245 X 413 X 610 H (MM)
Product Size : 49" X 16.25" X 24"

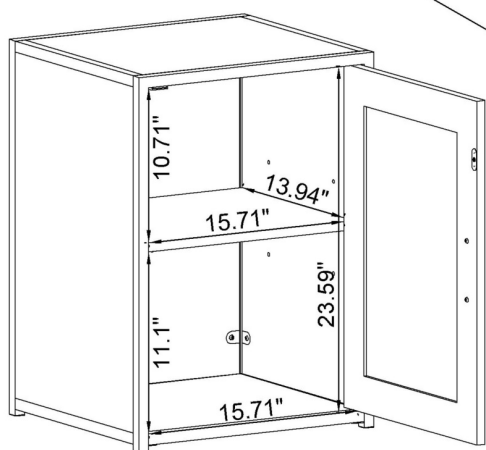
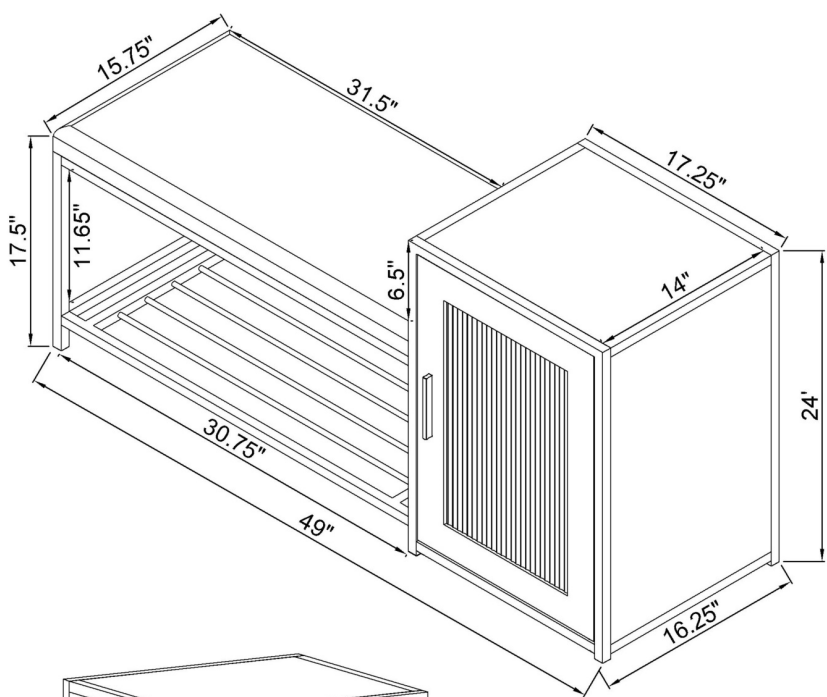

Note : Dimension tolerance $\pm 5\%$