

**ASSEMBLY INSTRUCTIONS**  
**COASTER FINE FURNITURE**



*Fine Furniture for every stage of life*

**700933**  
**TV STAND**

# ITEM: 700933



## ASSEMBLY INSTRUCTIONS

### ASSEMBLY TIPS:

1. Remove hardware from box and sort by size.
2. Please check to see that all hardware and parts are present prior to start of assembly.
3. Please follow attached instructions in the same sequence as numbered to assure fast & easy assembly.



### WARNING!

1. Don't attempt to repair or modify parts that are broken or defective. Please contact the store immediately.
2. This product is for home use only and not intended for commercial establishments.

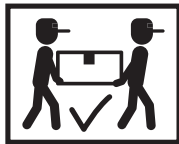

ASSEMBLY TIME

60 MINUTES

MAX TV SIZE : 85"

## PARTS IDENTIFICATION

A LEFT SIDE PANEL

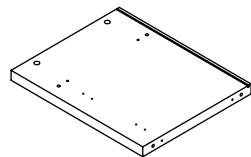

1 PC

B RIGHT SIDE PANEL

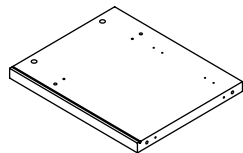

1 PC

C MIDDLE DIVIDER PANEL

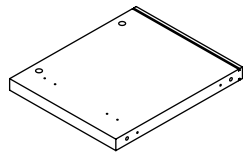

1 PC

D LEFT RIGHT MIDDLE DIVIDER PANEL

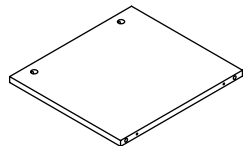

2 PCS

E TOP DIVIDER PANEL

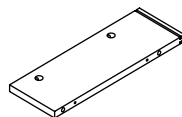

1 PC

F BOTTOM PANEL

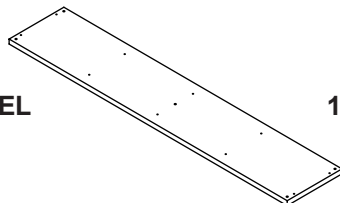

1 PC

G CROSS PANEL

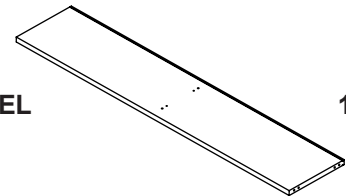

1 PC

H TOP PANEL

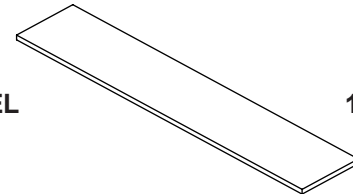

1 PC

I BACK UPPER PANEL

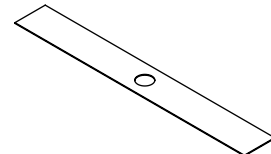

2 PCS

J BACK LOWER PANEL

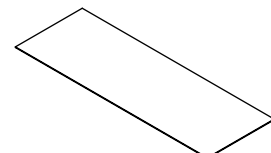

2 PCS

K DOOR

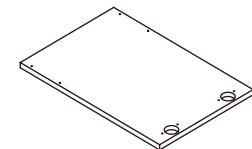

4 PCS

### NOTE:

Phillips head screw driver is required in the assembly process; however, manufacturer does not provide this item.

## HARDWARE IDENTIFICATION

Z							
NO	DESCRIPTION	FIGURE	Q'TY	NO	DESCRIPTION	FIGURE	Q'TY
1	GLUE 40g		1 PC	8	HINGE Ø35mm SR		8 PCS
2	WOODEN DOWEL Ø8 x 30mm		28 PCS	9	HINGE SCREW Ø4x15mm SR		32 PCS
3	CAM BOLT Ø7 x 35.5mm SR		16 PCS	10	PLASTIC COVER Ø 52mm		2 PCS
4	CAM LOCK Ø15 x 12mm SR		16 PCS	11	FOOT Ø35xH19mm		5 PCS
5	BOLT Ø9.5 x 55mm SR		12 PCS	12	BACK PANEL SUPPORT		6 PCS
6	HANDLE L=120mm BLK		4 PCS	13	BACK PANEL SUPPORT SCREW Ø3 x 19mm SR		6 PCS
7	RAIL SCREW Ø3x15mm BLK		8 PCS	14	STICKER Ø20mm		3 PCS

Z6, Z8, Z10, Z11 not included in blister packaging.

**NOTE:**

Phillips head screw driver is required in the assembly process; however, manufacturer does not provide this item.

ITEM: 700933

**COASTER**  
FINE FURNITURE

**STEP 1**

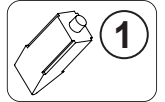

1



2

x 8

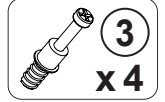

3

x 4

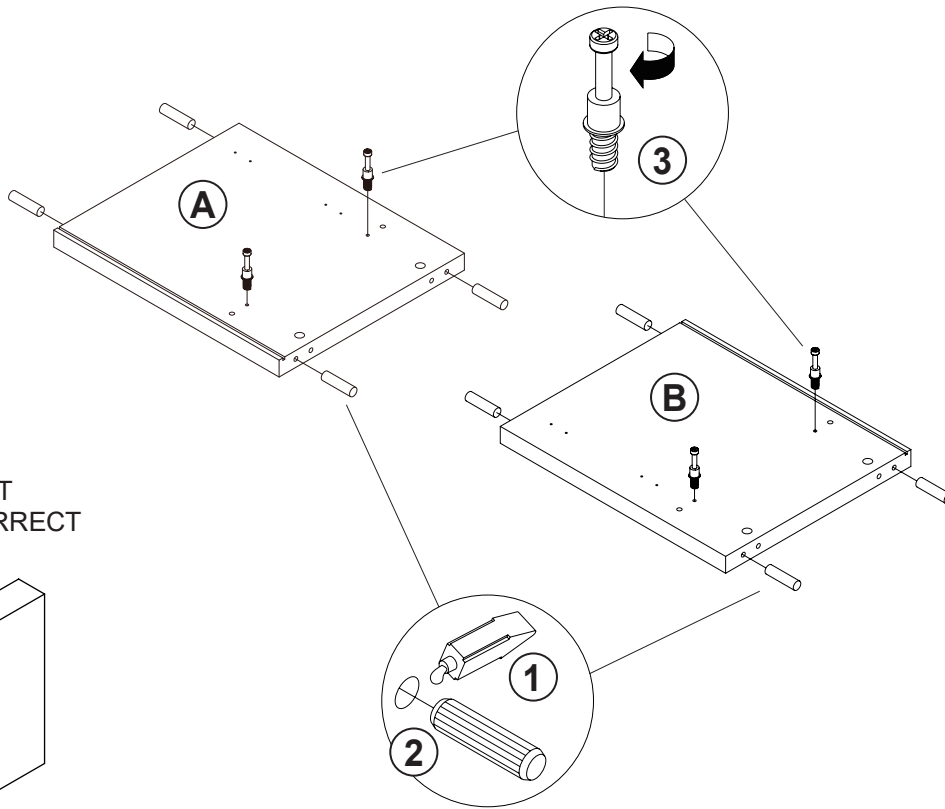

INCORRECT  
CORRECT

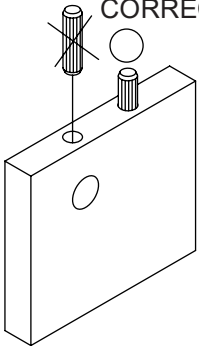

Apply glue on all wooden dowels to ensure integrity of the structure.

**STEP 2**

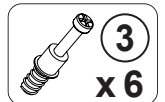

3

x 6

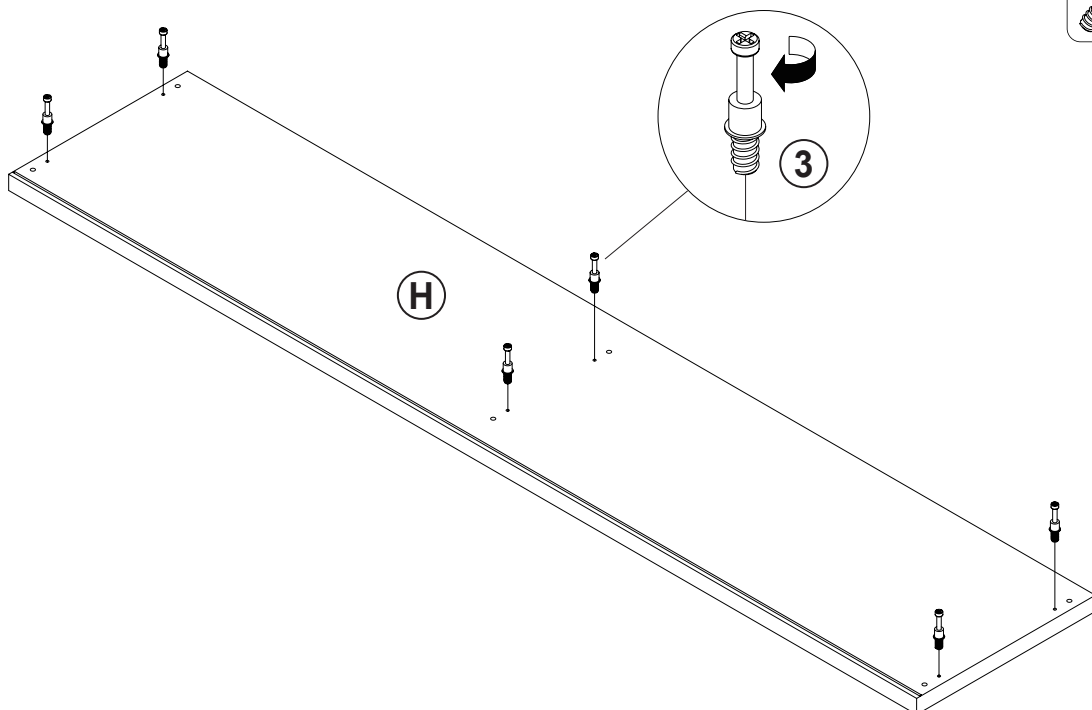

ITEM: 700933

**COASTER**  
FINE FURNITURE

**STEP 3**

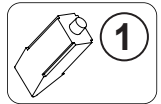

1

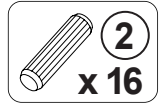

2

x 16

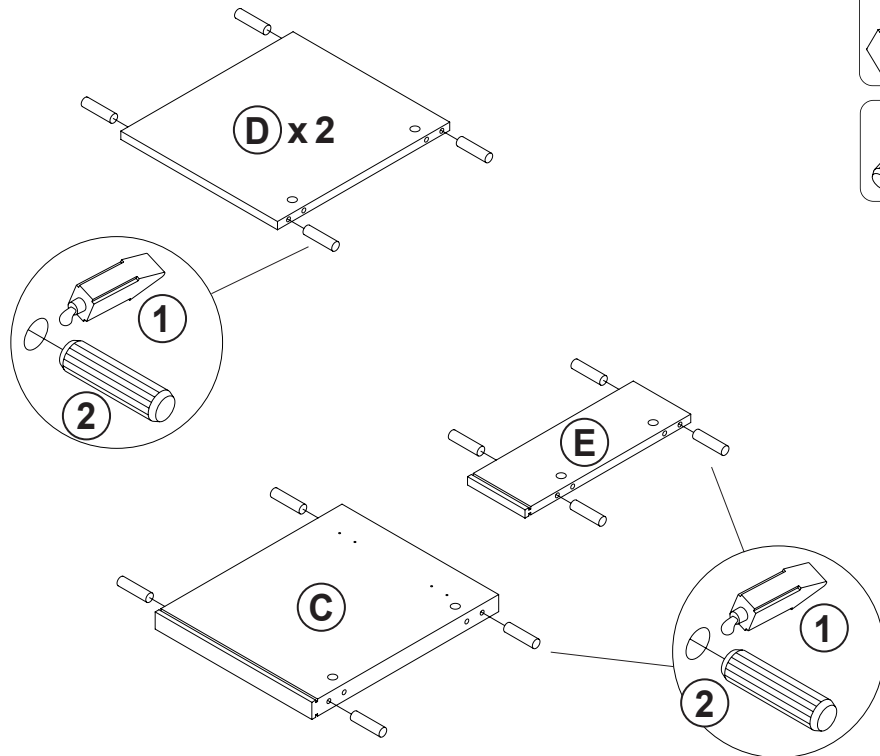

INCORRECT  
CORRECT

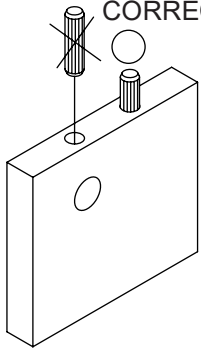

Apply glue on all wooden dowels to ensure integrity of the structure.

**STEP 4**

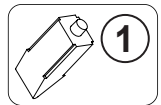

1

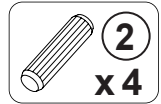

2

x 4

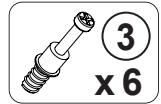

3

x 6

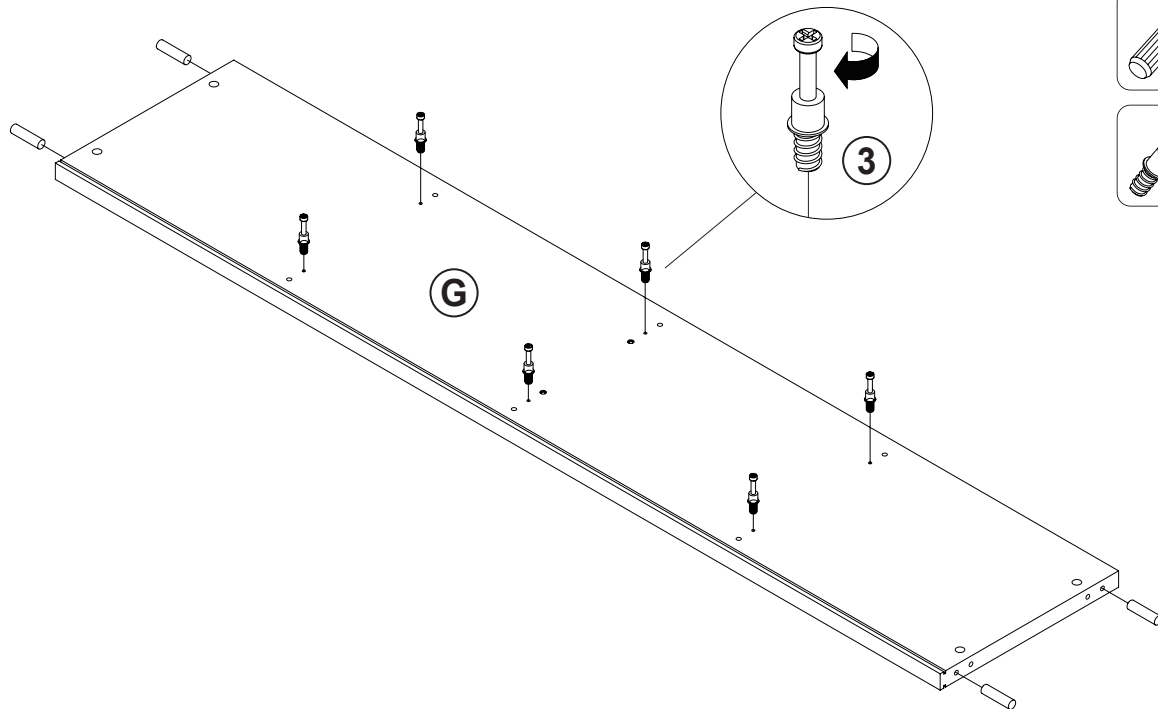

ITEM: 700933

**STEP 5**

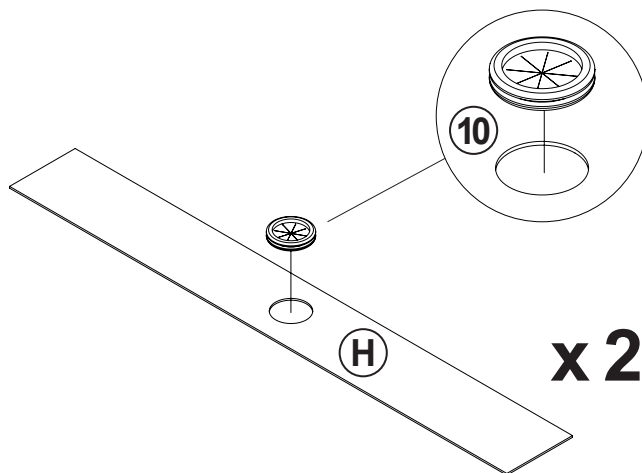
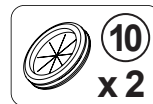

**STEP 6**

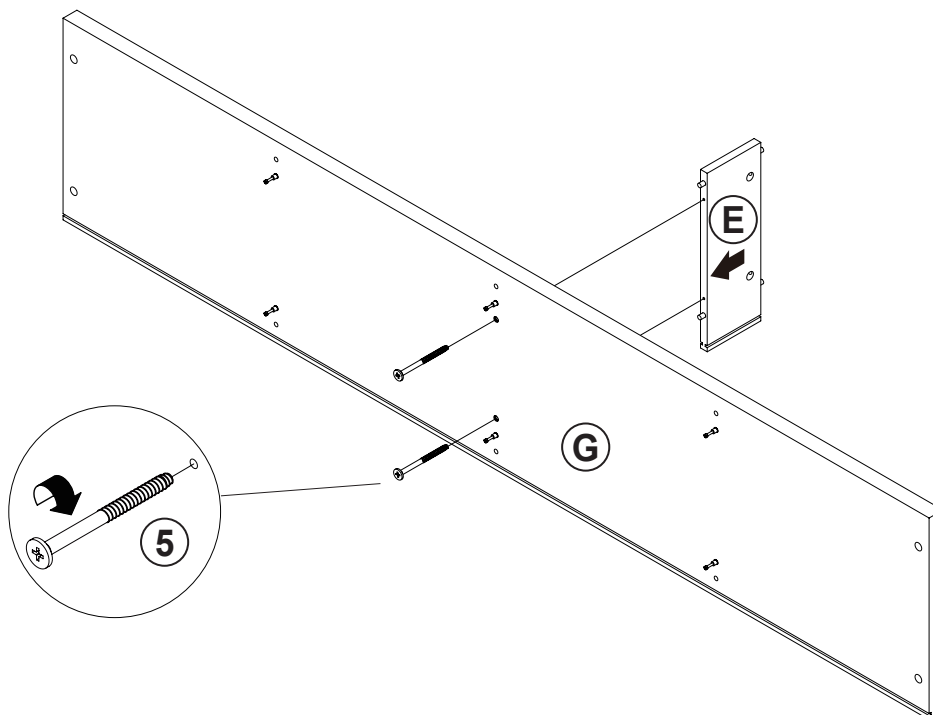

ITEM: 700933

**COASTER**<sup>®</sup>

FINE FURNITURE

**STEP 7**

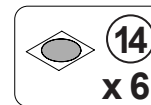
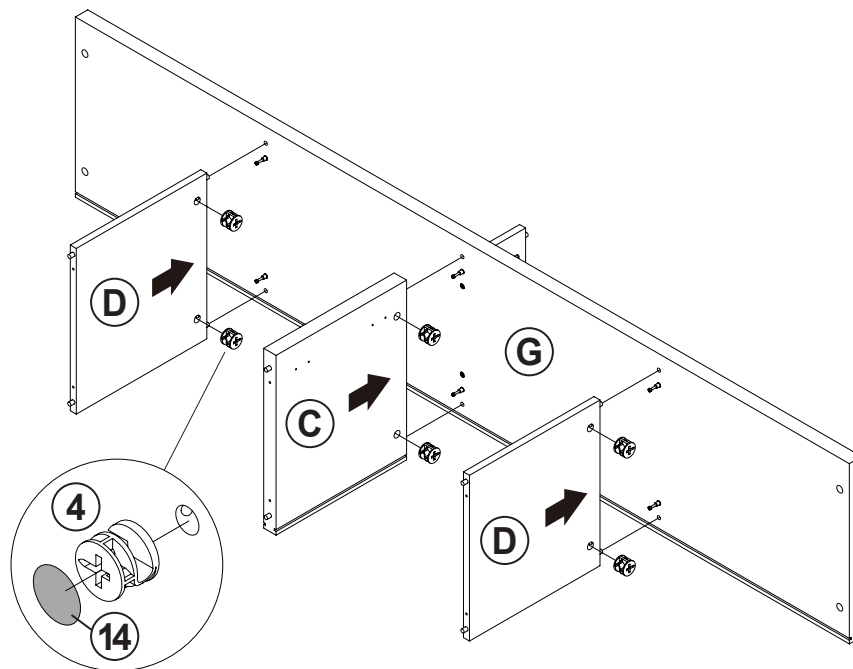

**STEP 8**

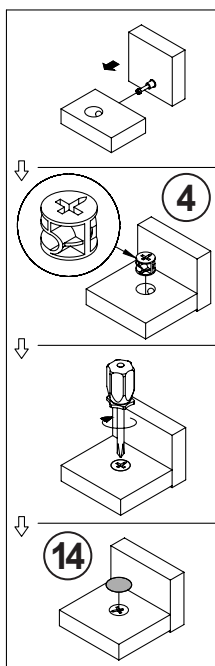
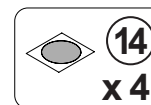
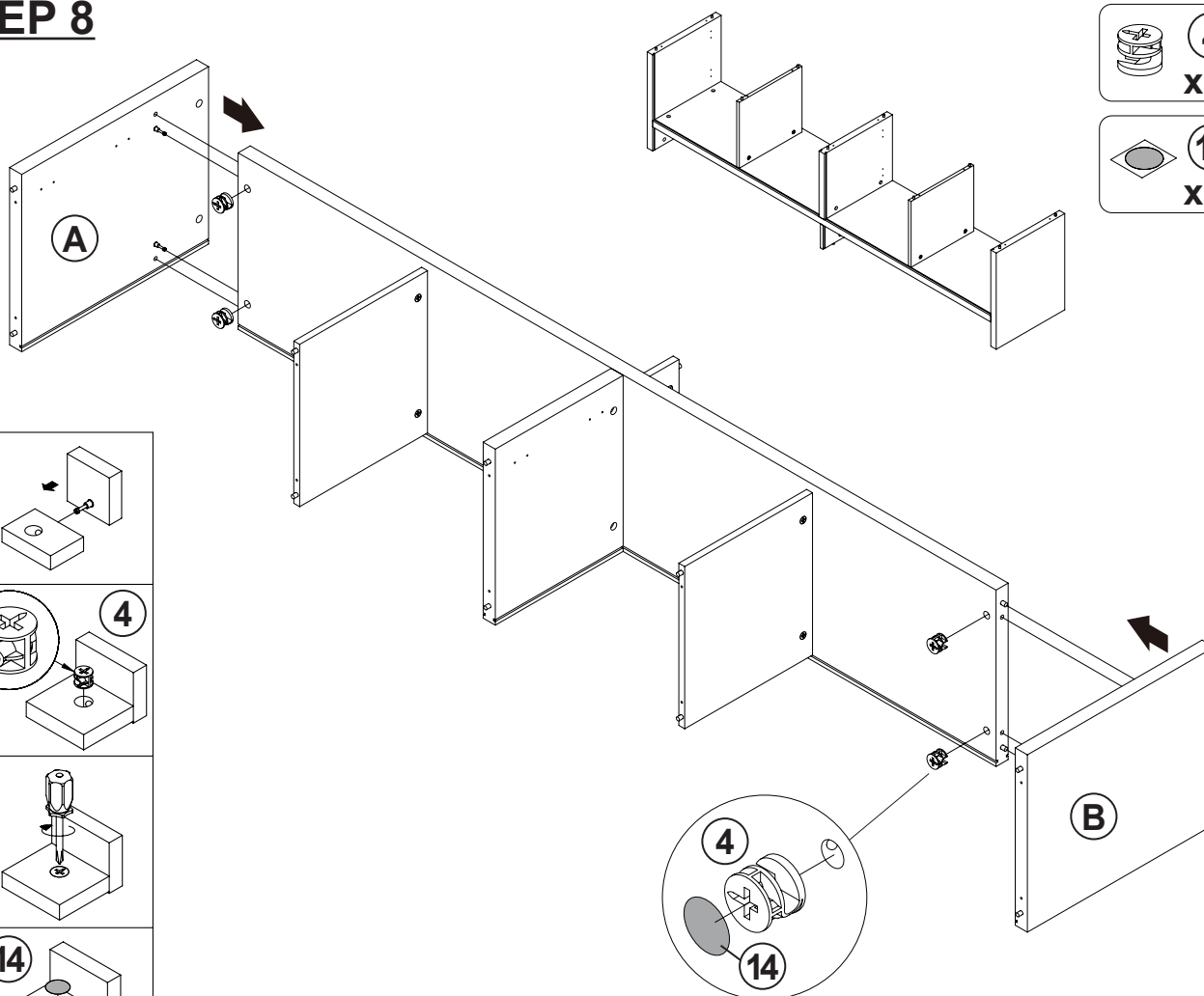

ITEM: 700933

**COASTER**  
FINE FURNITURE

**STEP 9**

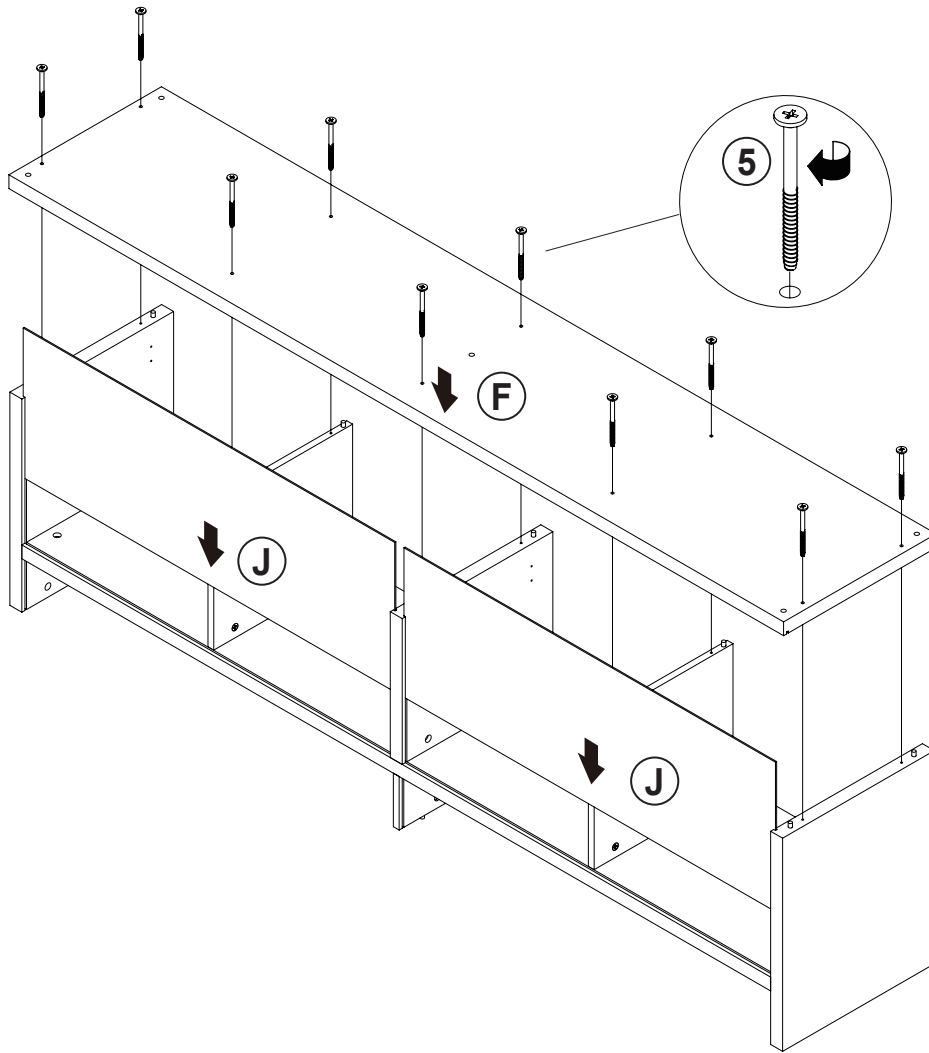

**STEP 10**

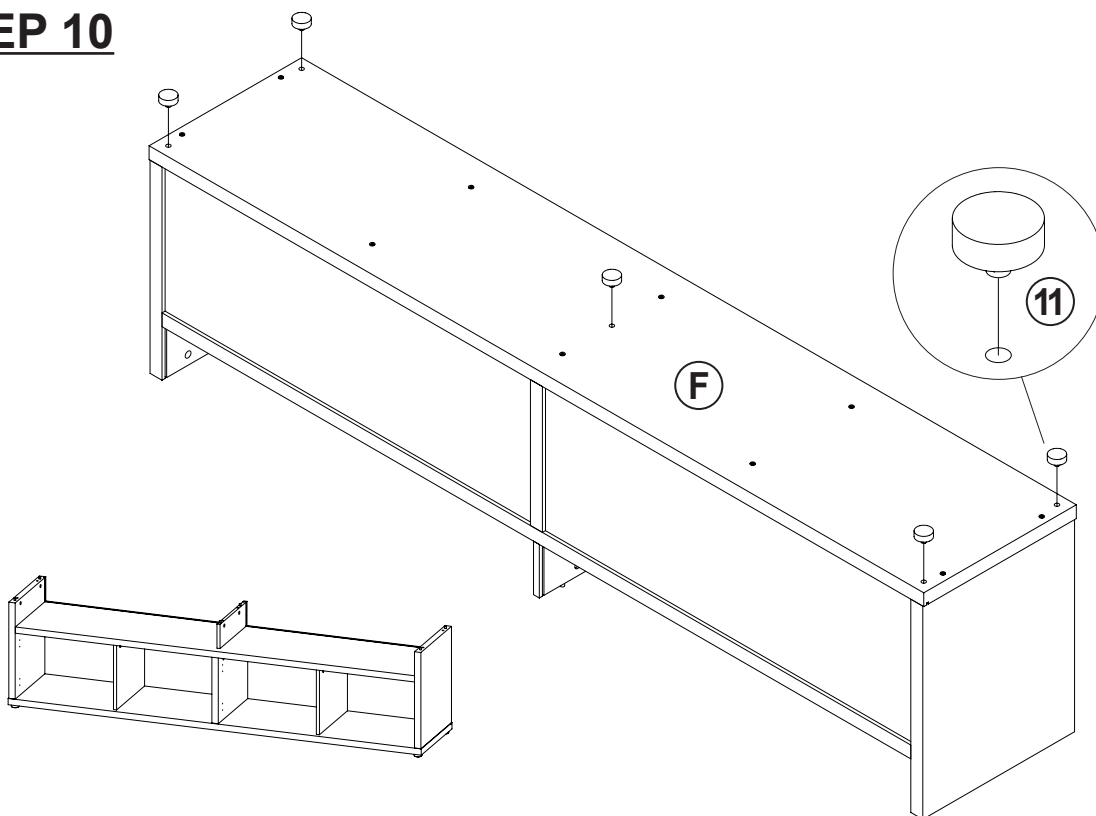

ITEM: 700933

**COASTER**<sup>®</sup>

FINE FURNITURE

**STEP 11**

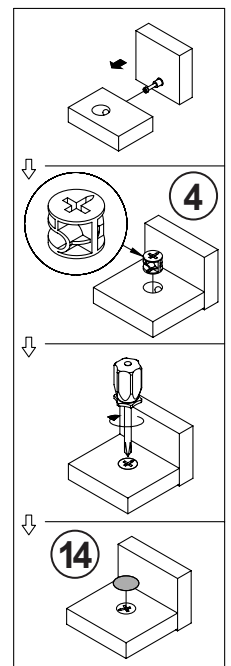
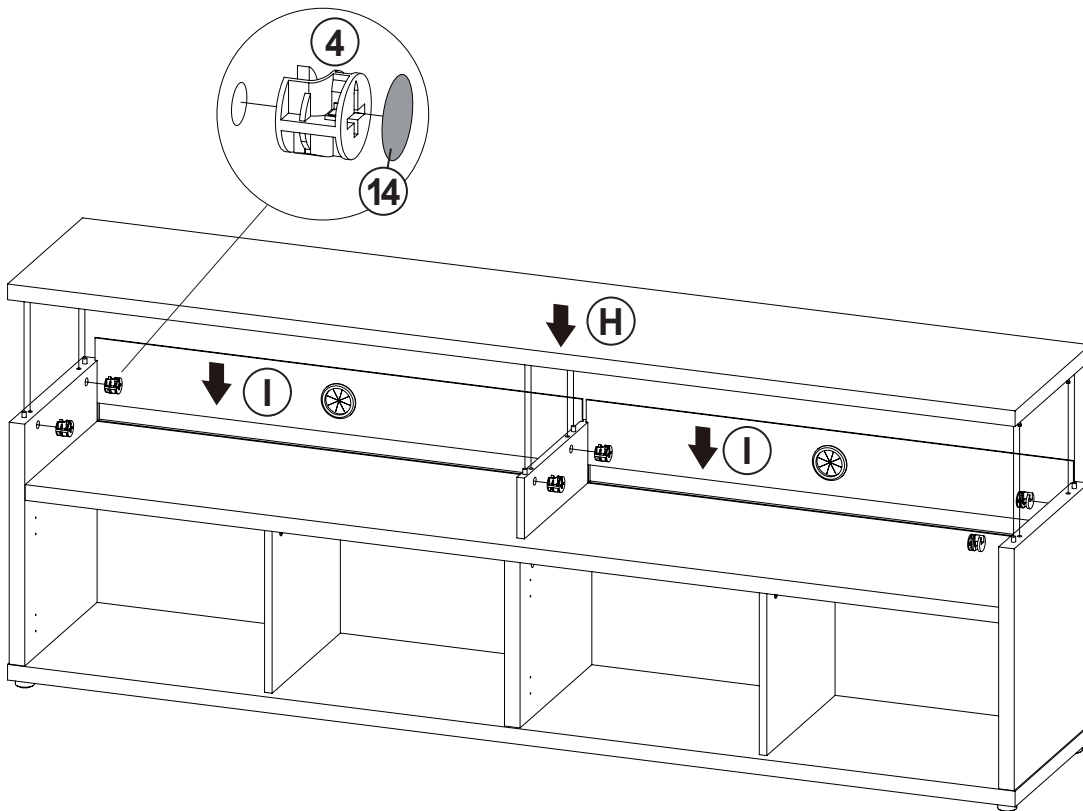
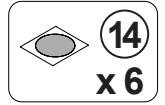

**STEP 12**

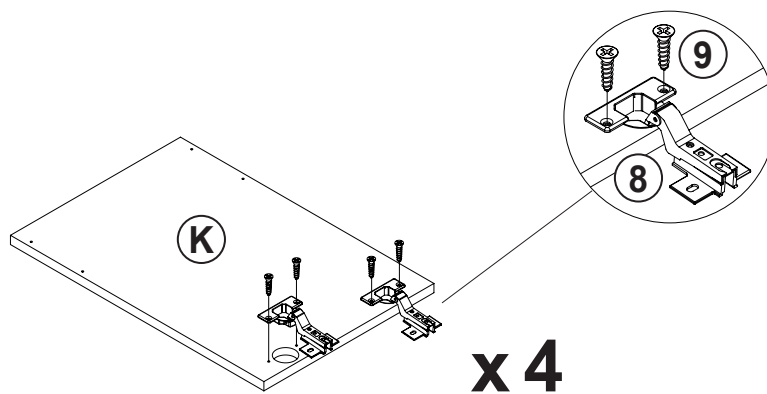
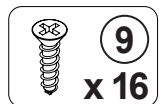
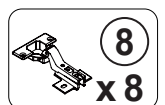

**x 4**

ITEM: 700933

**STEP 13**

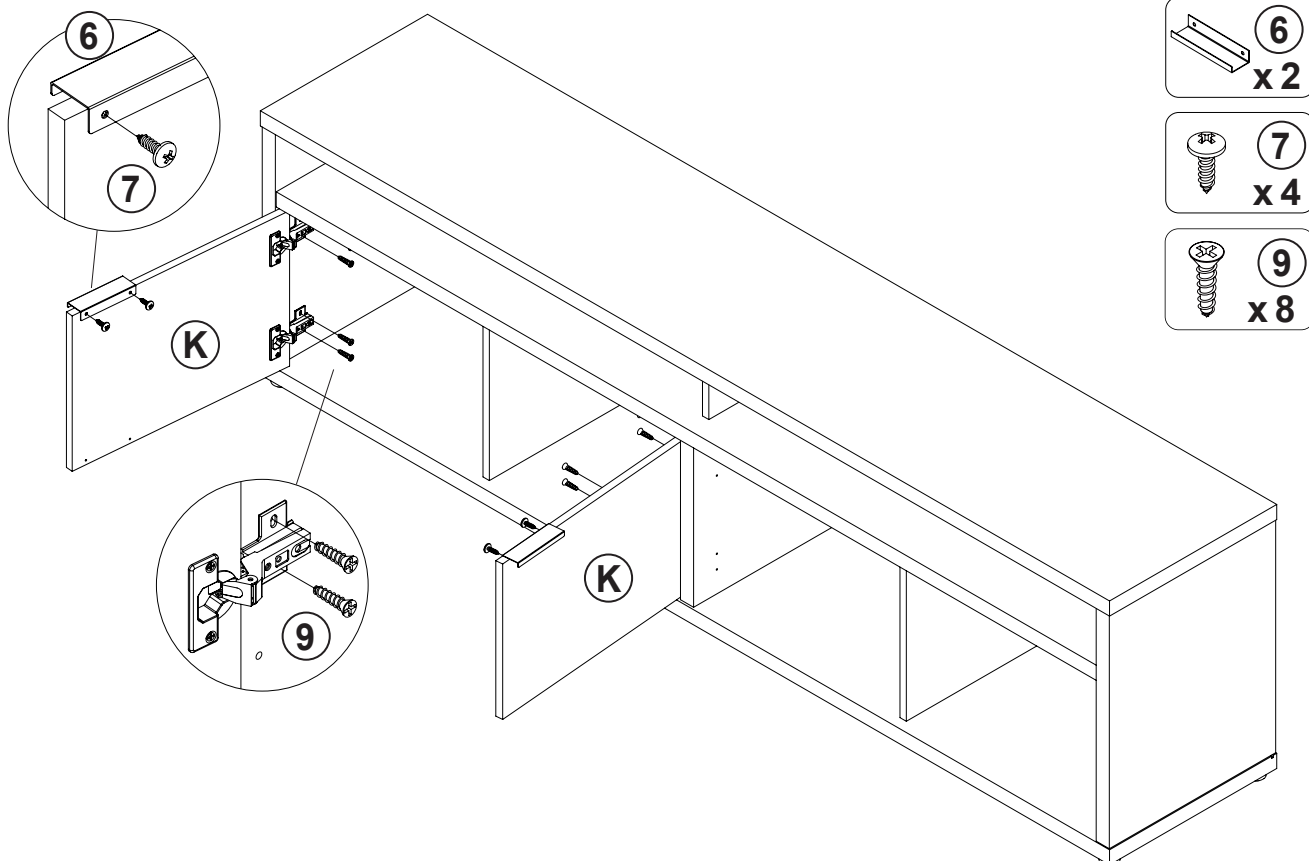

**STEP 14**

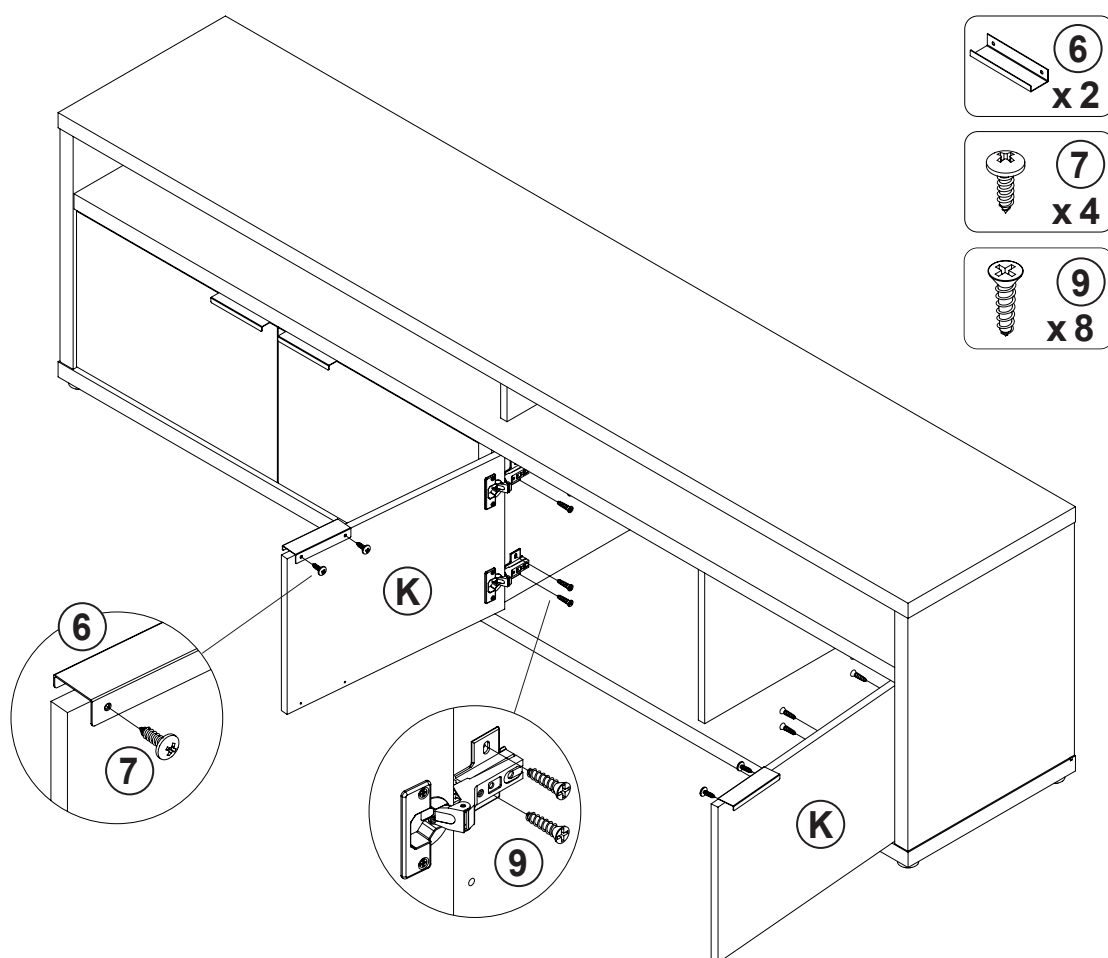

ITEM: 700933

**STEP 15**

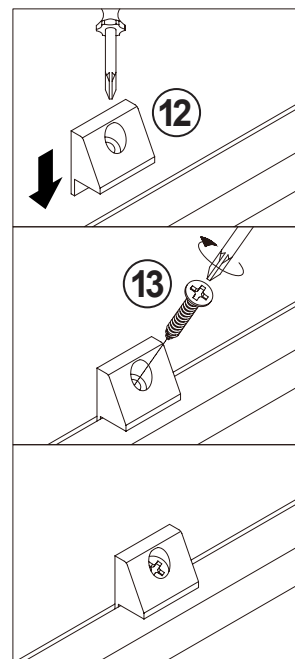
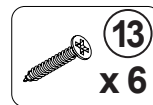
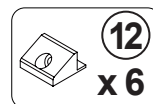
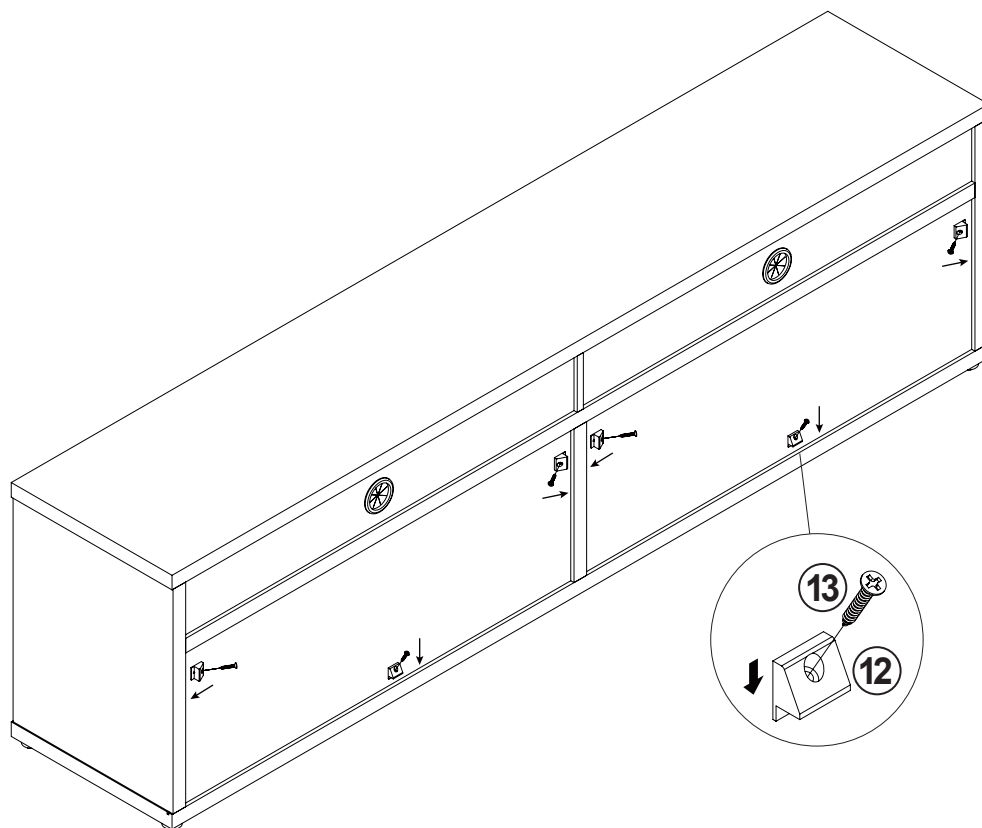

**STEP 16**

**COMPLETE**

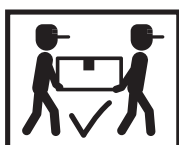
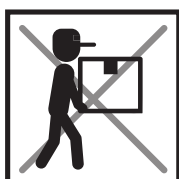
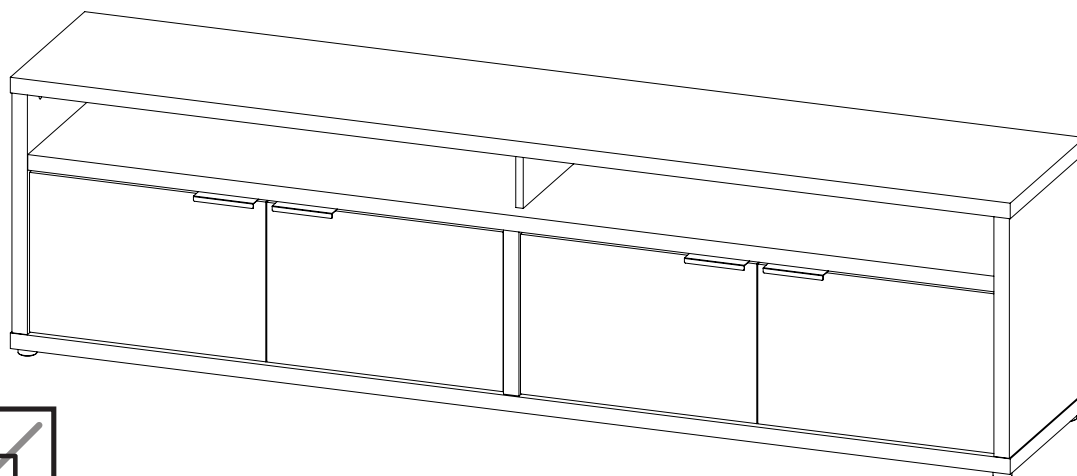

ITEM: 700933

