

**ASSEMBLY INSTRUCTIONS**  
**COASTER FINE FURNITURE**



*Fine Furniture for every stage of life*

**315901T**  
**TWIN HEADBOARD**

# ITEM:315901T

## ASSEMBLY INSTRUCTIONS

### ASSEMBLY TIPS:

1. Remove hardware from box and sort by size.
2. Please check to see that all hardware and parts are present prior to start of assembly.
3. Please follow attached instructions in the same sequence as numbered to assure fast & easy assembly.



### WARNING!

1. Don't attempt to repair or modify parts that are broken or defective. Please contact the store immediately.
2. This product is for home use only and not intended for commercial establishments.





ASSEMBLY TIME

30 MINUTES

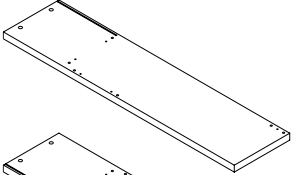
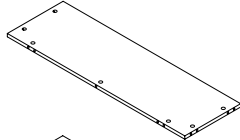
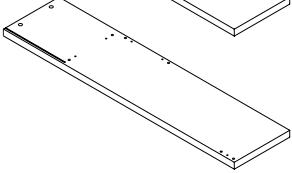
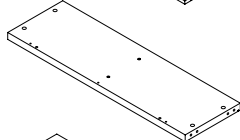
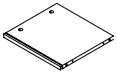
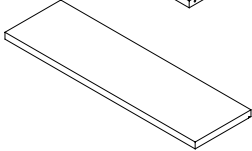
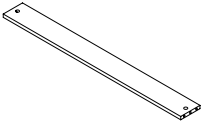
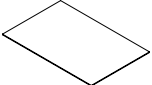
## PARTS IDENTIFICATION

A	LEFT SIDE PANEL		1 PC	E	FRONT MIDDLE PANEL		1 PC
B	RIGHT SIDE PANEL		1 PC	F	CROSS PANEL		1 PC
C	UPPER DIVIDER PANEL		1 PC	G	TOP PANEL		1 PC
D	LOWER CROSS PANEL		1 PC	H	BACK PANEL		2 PCS

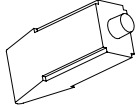
## HARDWARE IDENTIFICATION

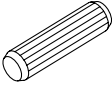
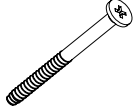
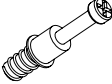
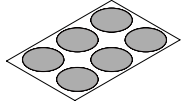
Z							
NO	DESCRIPTION	FIGURE	Q'TY	NO	DESCRIPTION	FIGURE	Q'TY
1	GLUE 40g		1 PC	4	CAM LOCK Ø15x12mm SR		19 PCS
2	WOODEN DOWEL Ø8x30mm		22 PCS	5	BOLT Ø9.5x55mm SR		2 PCS
3	CAM BOLT Ø7x35.5mm SR		19 PCS	6	STICKER Ø20mm		4 PCS

### NOTE:

Phillips head screw driver is required in the assembly process; however, manufacturer does not provide this item.

# ITEM: 315901T

## STEP 1

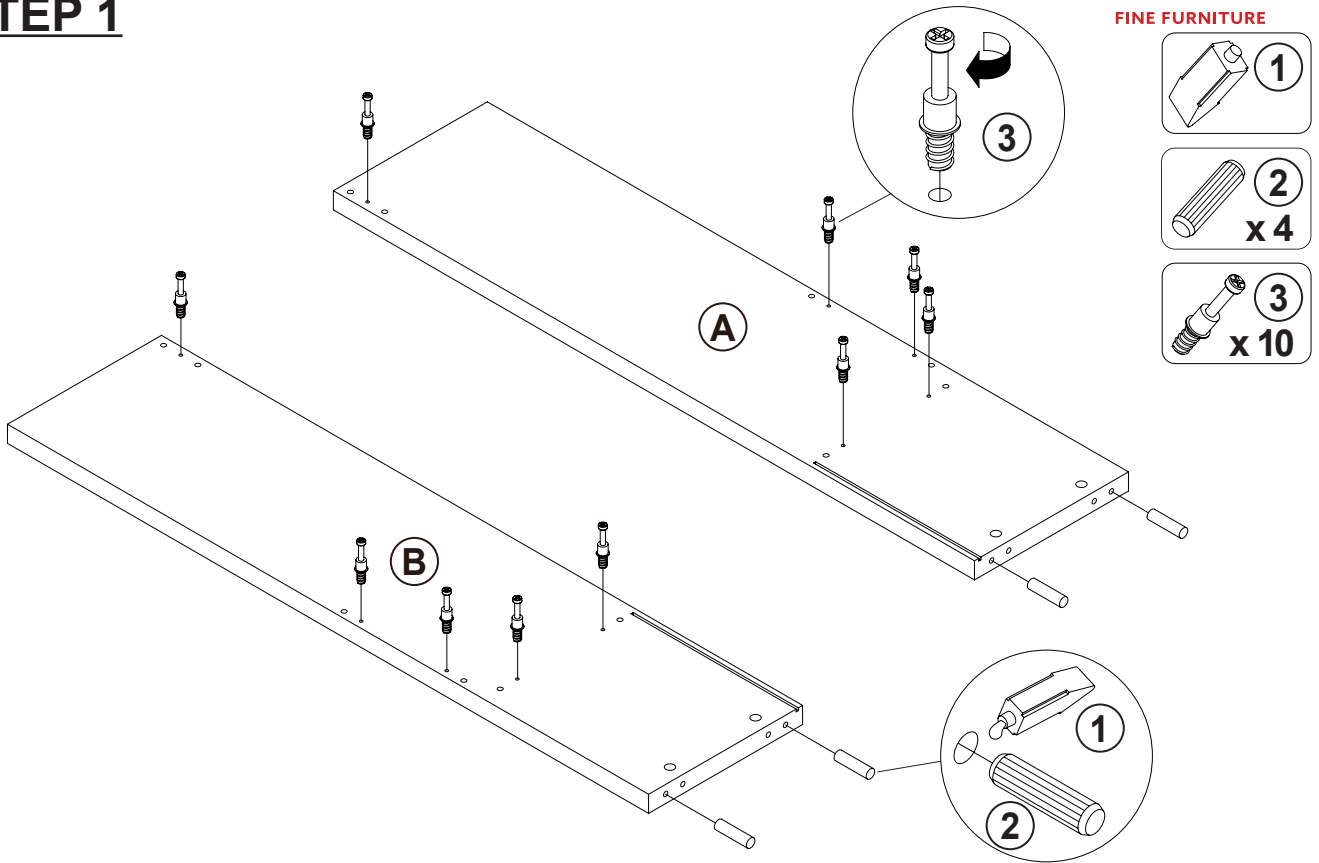

## STEP 2

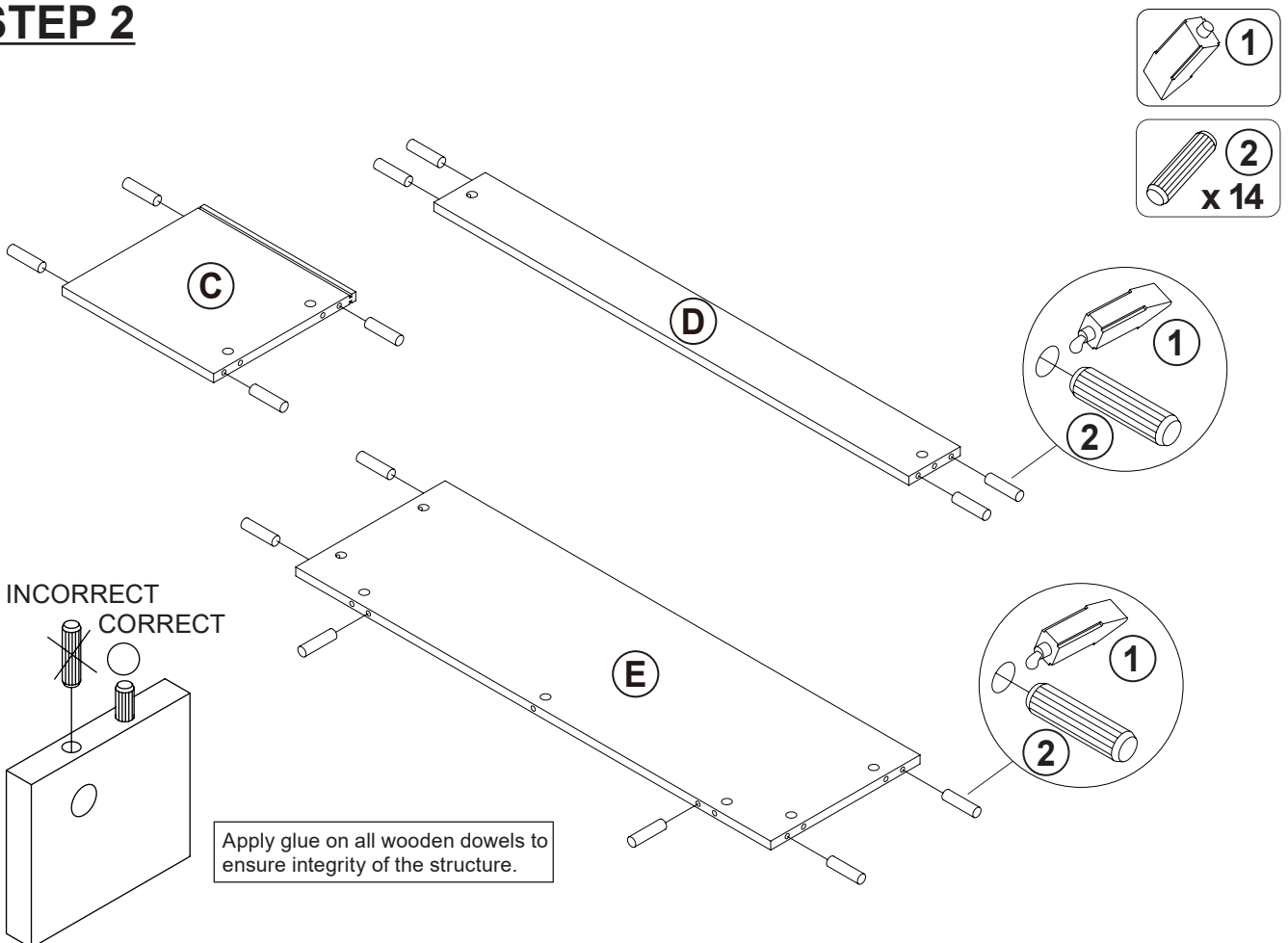

ITEM: **315901T**

**COASTER**  
FINE FURNITURE

**STEP 3**

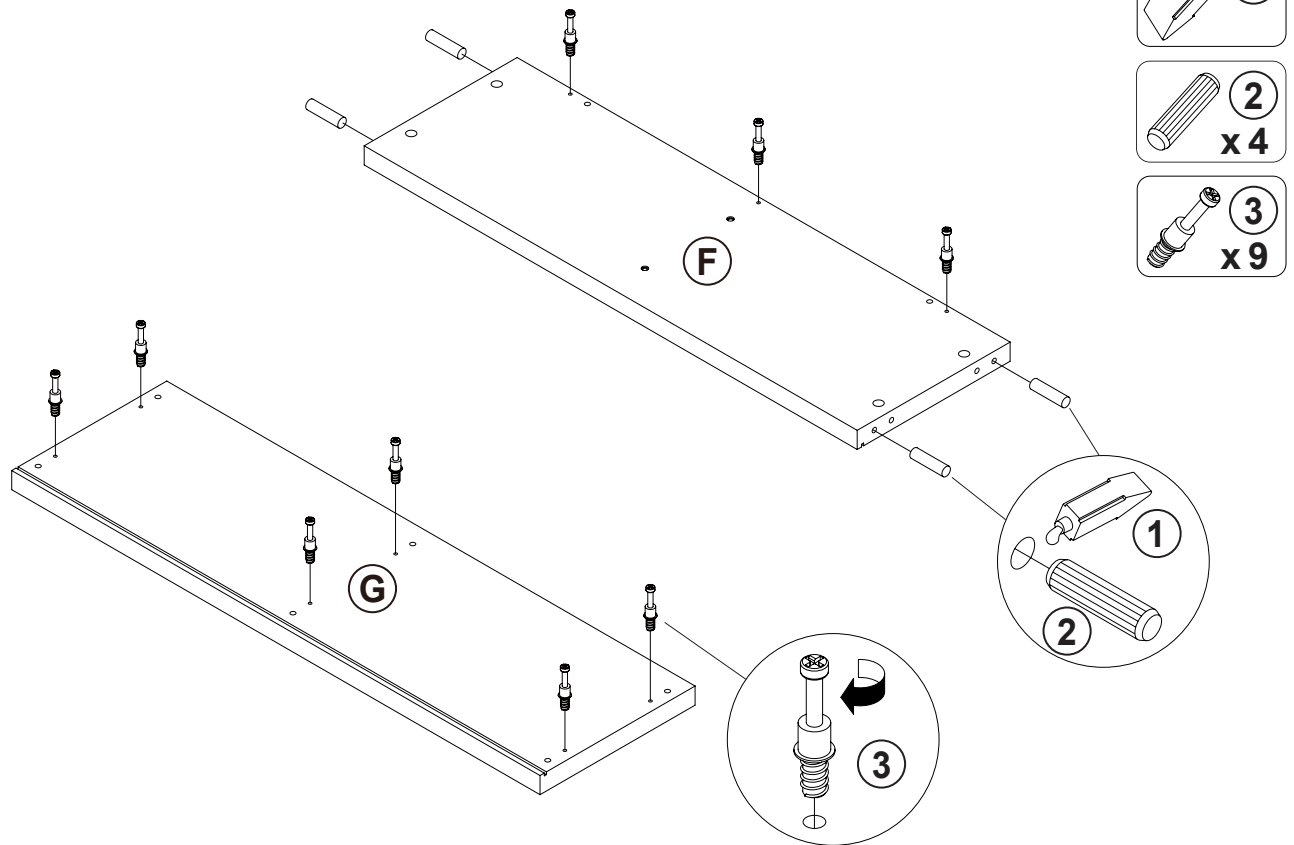

**STEP 4**

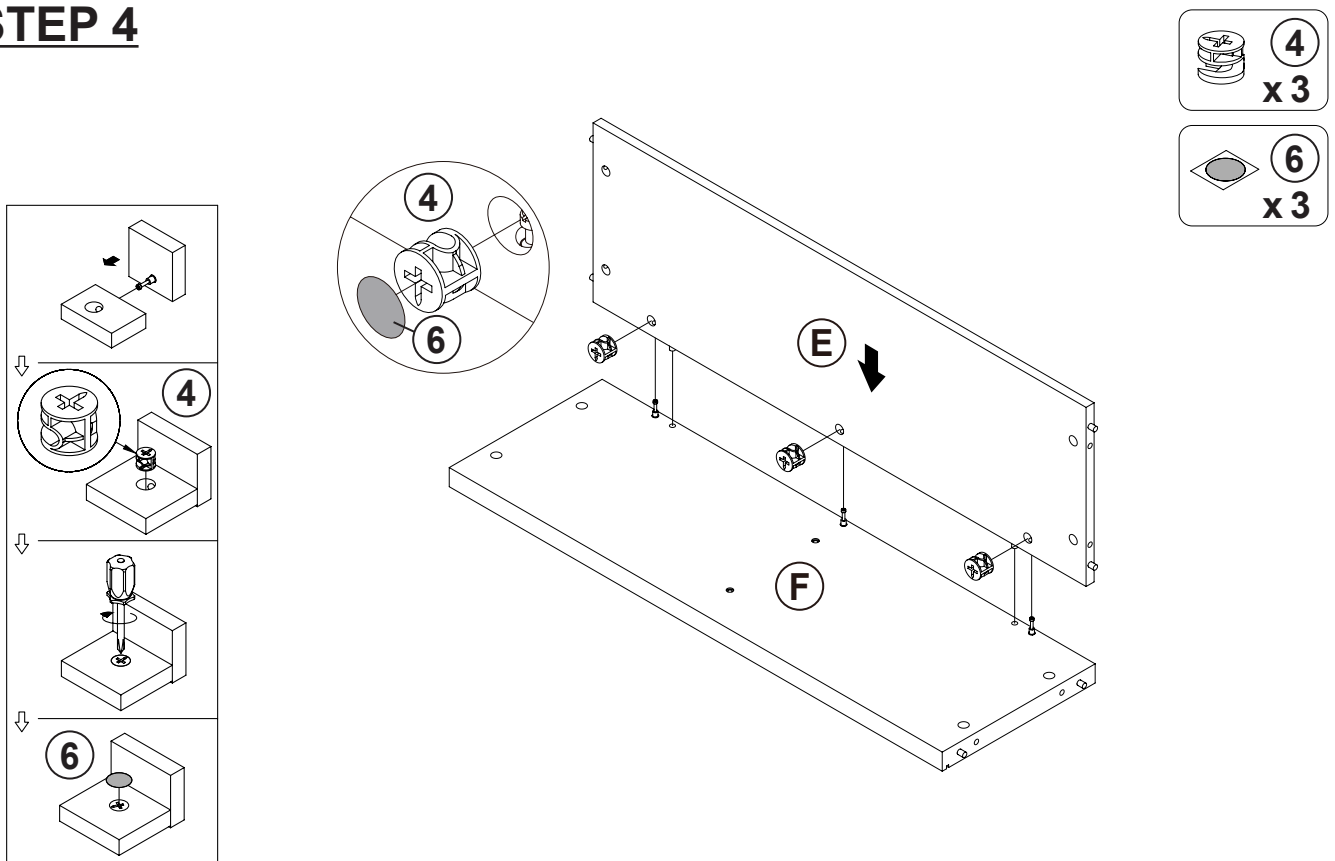

ITEM: **315901T**

**COASTER**<sup>®</sup>

FINE FURNITURE

**STEP 5**

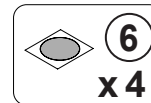
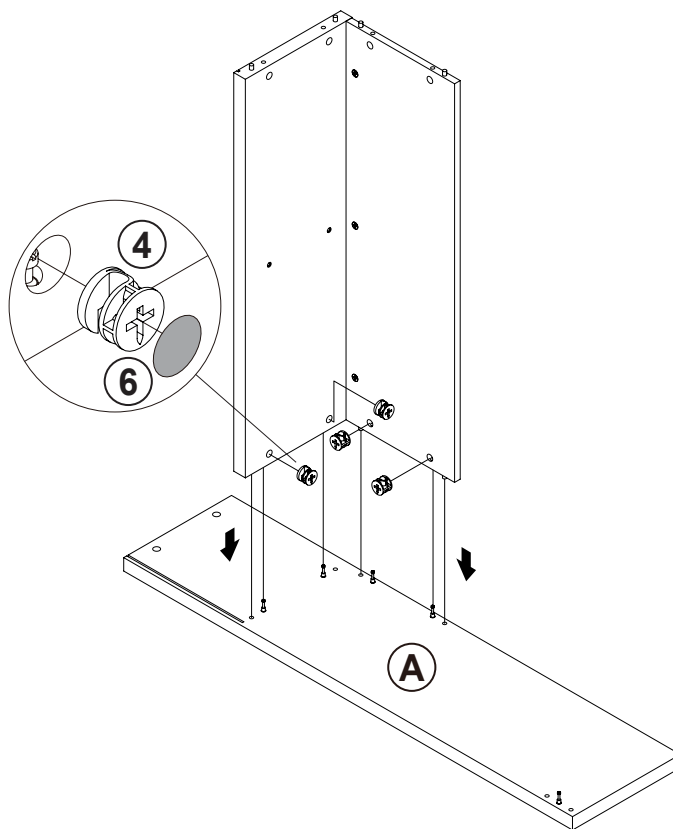

**STEP 6**

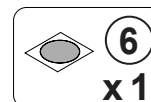
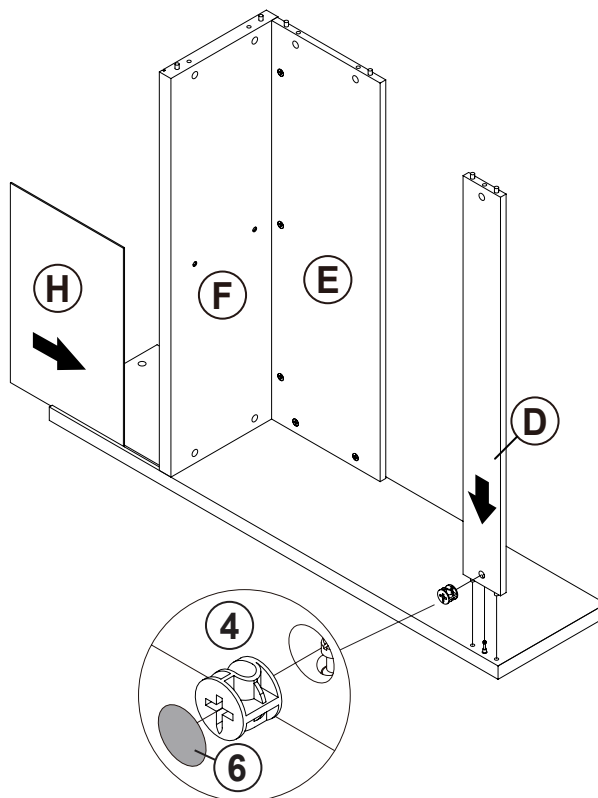

ITEM: **315901T**

**STEP 7**

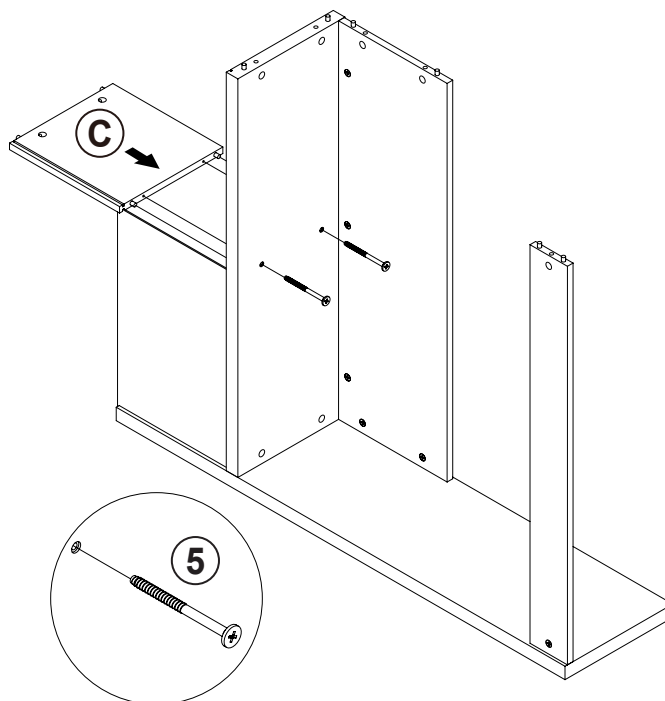
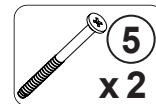

**STEP 8**

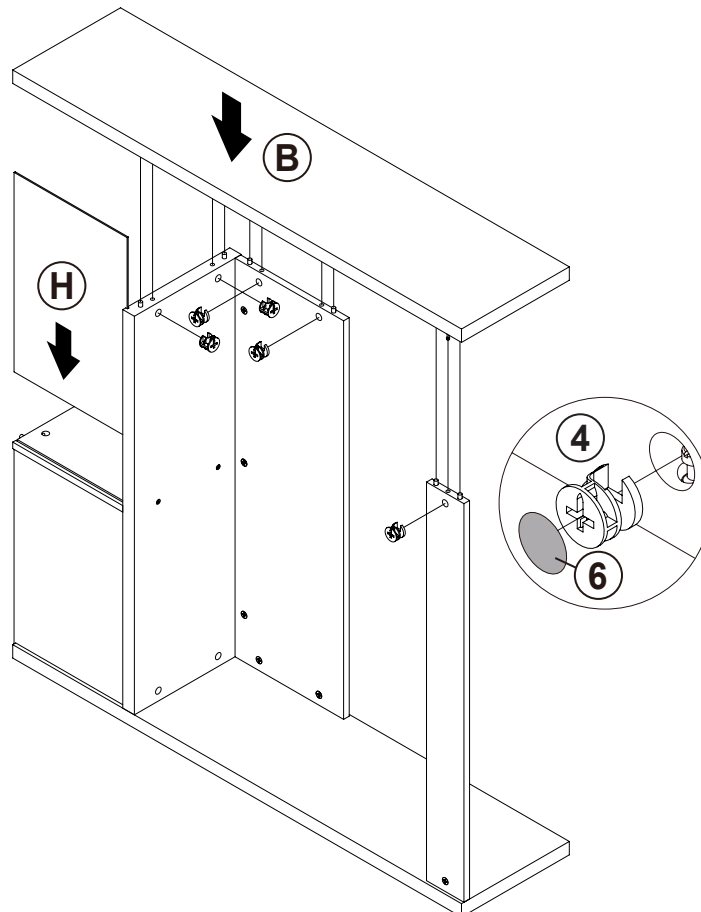
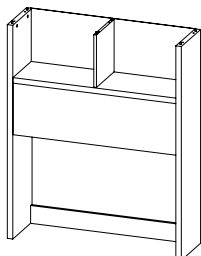
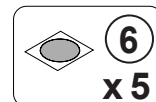

ITEM: **315901T**

**COASTER**<sup>®</sup>

FINE FURNITURE

**STEP 9**

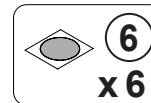
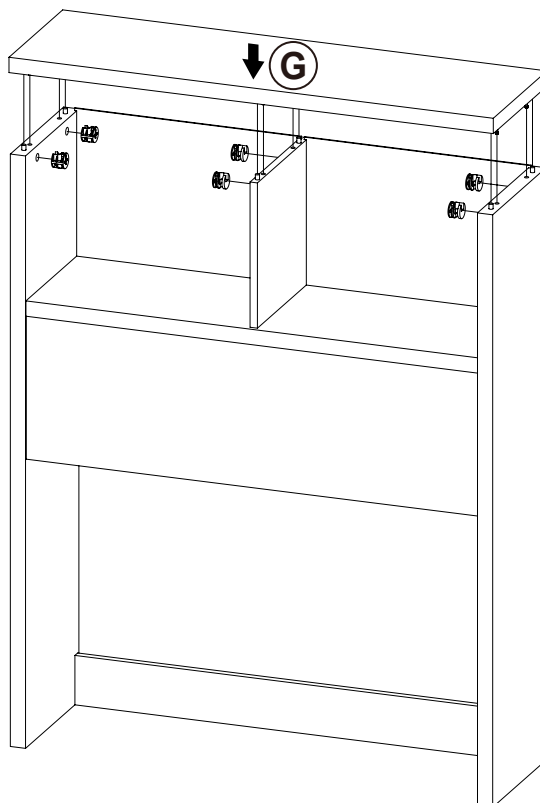
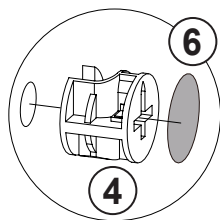

**STEP 10**

**COMPLETE**

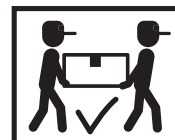
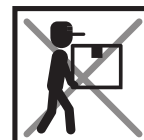
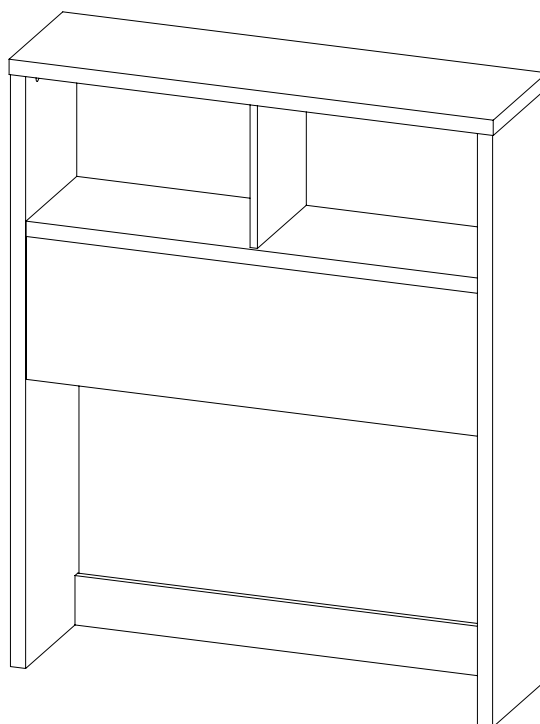

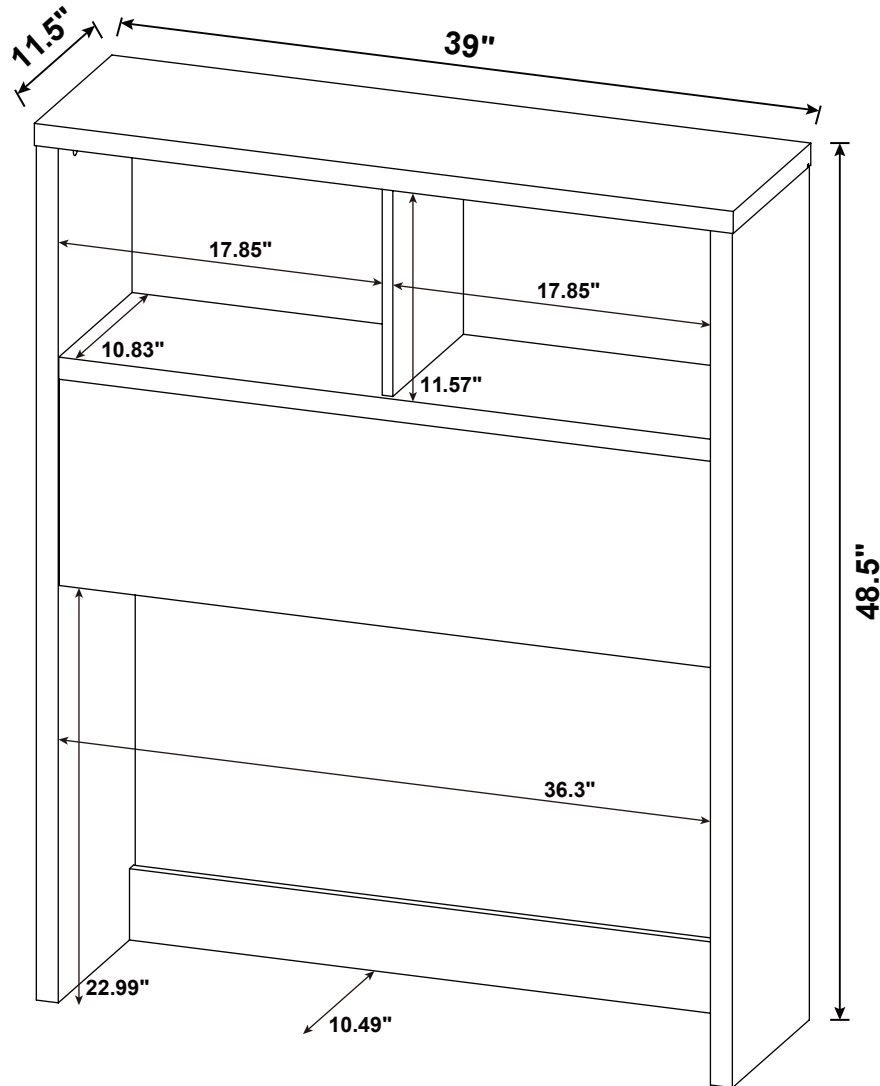

Note : Dimension tolerance  $\pm 5\%$

## ANTI-TIPPING INSTALLMENT INSTRUCTIONS FURNITURE TIPPING RESTRAINT

### WARNING

Injury may result from tipping furniture.  
This restraint may protect against tipping furniture.  
Do not allow children to climb on furniture.  
This restraint is not a substitute for proper adult supervision.  
Failure to detach this restraint before moving the furniture may result in injury and damage.

This restraint must be screwed to a wood stud on the wall, using the long screw provided.

### STEP 1

Secure the bracket to the back top of the unit, using the short screw provided, as shown in the drawing.

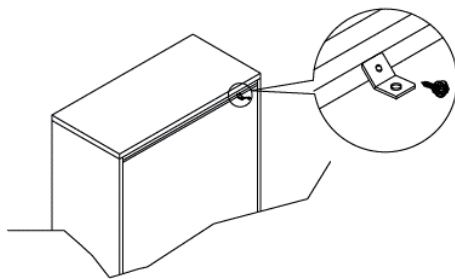

### STEP 2

Locate the wood stud on the wall, and secure the other bracket, 2 inches below the back of the unit.

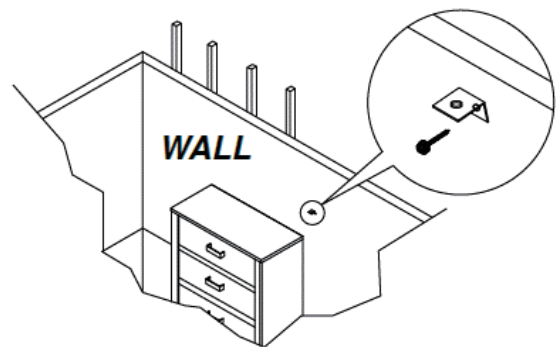

### STEP 3

Place the furniture into position so both mounting brackets are vertically in line. Lace the end of the restraint strap through the larger hole in each mounting bracket. Bring both ends together and slide the flat end through the locking end, and drag it through, until the slack is removed. Ensure that the strap is securely laced and locked.

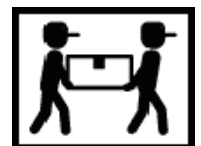
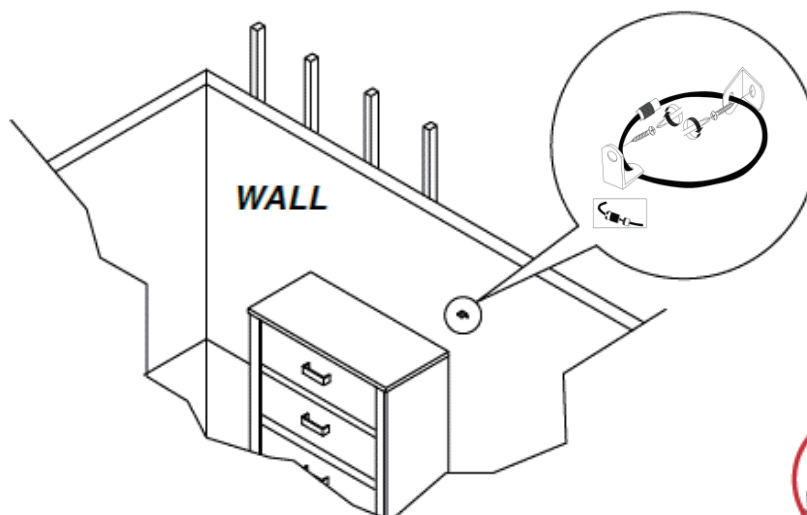

**ASSEMBLY INSTRUCTIONS**  
**COASTER FINE FURNITURE**



*Fine Furniture for every stage of life*

**802693**  
**BOOKCASE**

# ITEM: 802693

## ASSEMBLY INSTRUCTIONS

### ASSEMBLY TIPS:

1. Remove hardware from box and sort by size.
2. Please check to see that all hardware and parts are present prior to start of assembly.
3. Please follow attached instructions in the same sequence as numbered to assure fast & easy assembly.



### WARNING!

1. Don't attempt to repair or modify parts that are broken or defective. Please contact the store immediately.
2. This product is for home use only and not intended for commercial establishments.

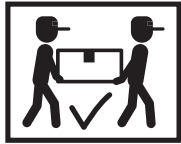

ASSEMBLY TIME

60 MINUTES



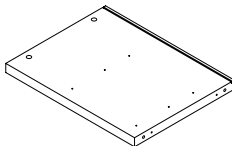
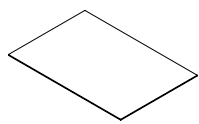
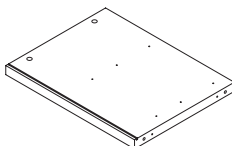
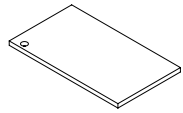
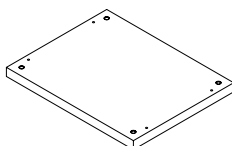
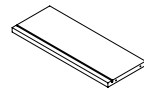
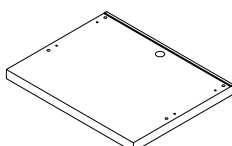
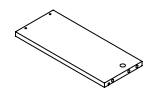
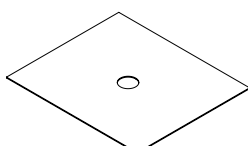
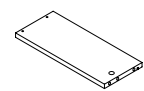
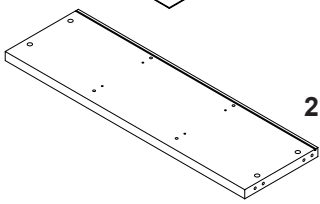
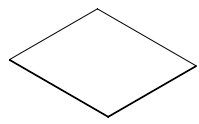
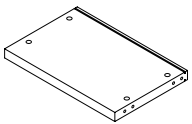
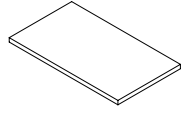
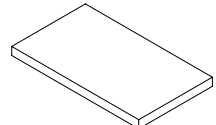







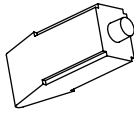

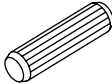
## PARTS IDENTIFICATION

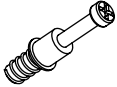
A	LEFT SIDE PANEL		1 PC	I	UPPER BACK PANEL		3 PCS
B	RIGHT SIDE PANEL		1 PC	J	UPPER DRAWER FRONT PANEL		1 PC
C	BOTTOM PANEL		1 PC	K	DRAWER BACK PANEL		2 PCS
D	MIDDLE CROSS PANEL		1 PC	L	DRAWER LEFT SIDE PANEL		2 PCS
E	BACK PANEL		1 PC	M	DRAWER RIGHT SIDE PANEL		2 PCS
F	UPPER SIDE PANEL		2 PCS	N	DRAWER BOTTOM PANEL		2 PCS
G	UPPER CROSS PANEL		2 PCS	O	LOWER DRAWER FRONT PANEL		1 PC
H	TOP PANEL		1 PC				

### NOTE:

Phillips head screw driver is required in the assembly process; however, manufacturer does not provide this item.

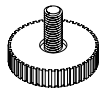
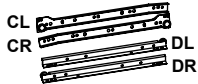
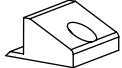
## HARDWARE IDENTIFICATION

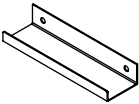
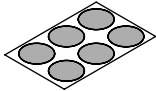
Z							
NO	DESCRIPTION	FIGURE	Q'TY	NO	DESCRIPTION	FIGURE	Q'TY
1	GLUE 40g		1 PC	10	HANDLE SCREW ø3x15mm BLK		4 PCS
2	WOODEN DOWEL ø8x30mm		32 PCS	11	LOCKER		1 PC
3	CAM BOLT ø7x35.5mm SR		24 PCS	12	SCREW ø3 x 18mm BLK		2 PCS
4	CAM LOCK ø15x12mm SR		24 PCS	13	TYPEA+C ELECTRICAL SOCKET		1 PC
5	BOLT ø9.5x55mm SR		4 PCS	14	PLASTIC COVER ø 52mm		1 PC
6	SCREW ø 4.3x35mm SR		8 PCS	15	FOOTHOLD		4 PCS
7	GLIDES L = 350mm BLK		2 PCS	16	BACK PANEL SUPPORT		6 PCS
8	GLIDES SCREW ø 3x12mm BLK		24 PCS	17	BACK PANEL SUPPORT SCREW ø3 x 19mm SR		6 PCS
9	HANDLE L=120mm BLK		2 PCS	18	STICKER ø 20mm		4 PCS

Z7,Z9,Z11,Z13,Z14 not included in blister packaging.

**NOTE:**

Phillips head screw driver is required in the assembly process; however, manufacturer does not provide this item.

ITEM: 802693

**COASTER**  
FINE FURNITURE

**STEP 1**

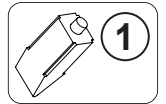
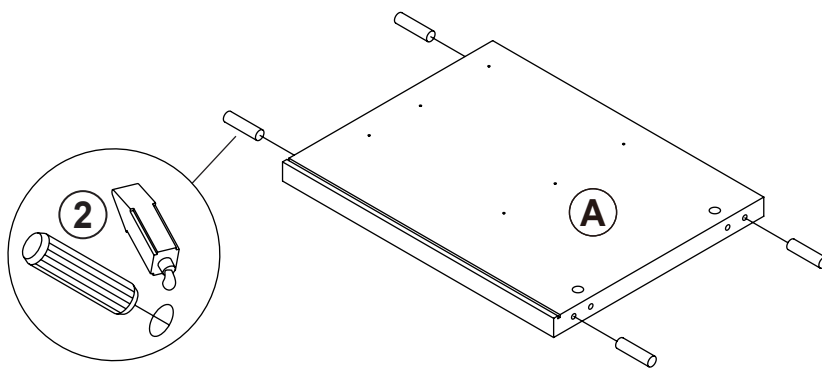

1

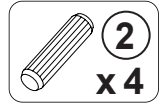

2

x 4

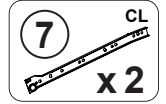

7

CL

x 2

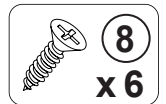

8

x 6

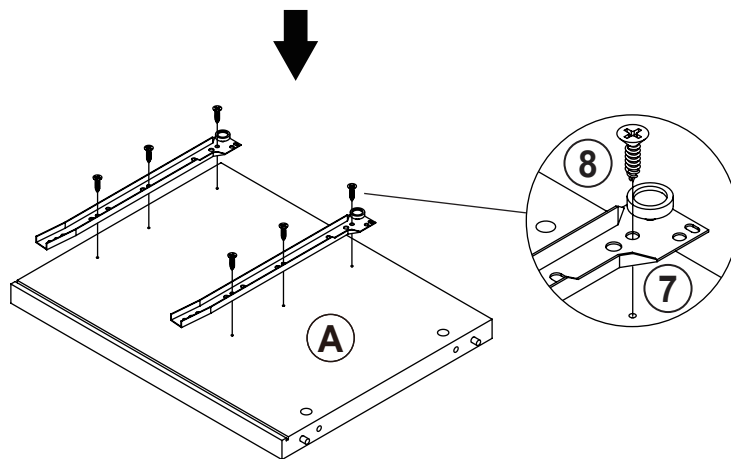

**STEP 2**

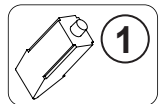
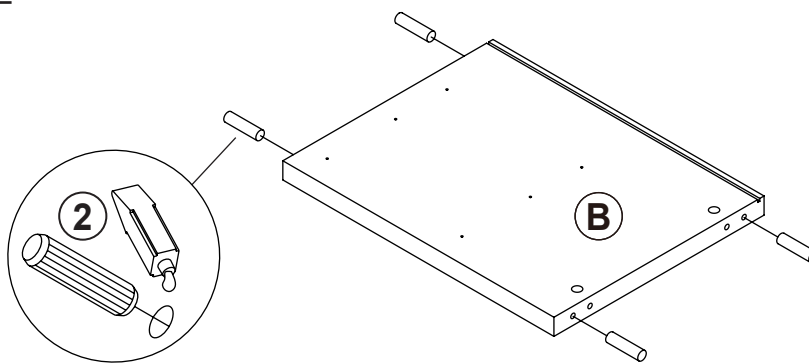

1

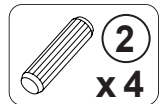

2

x 4

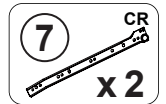

7

CR

x 2

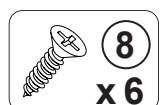

8

x 6

INCORRECT  
CORRECT

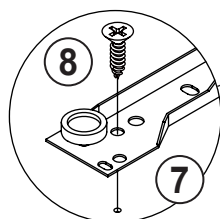
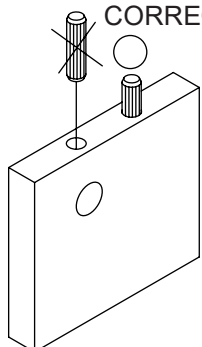

Apply glue on all wooden dowels to ensure integrity of the structure.

ITEM: 802693

**COASTER**  
FINE FURNITURE

**STEP 3**

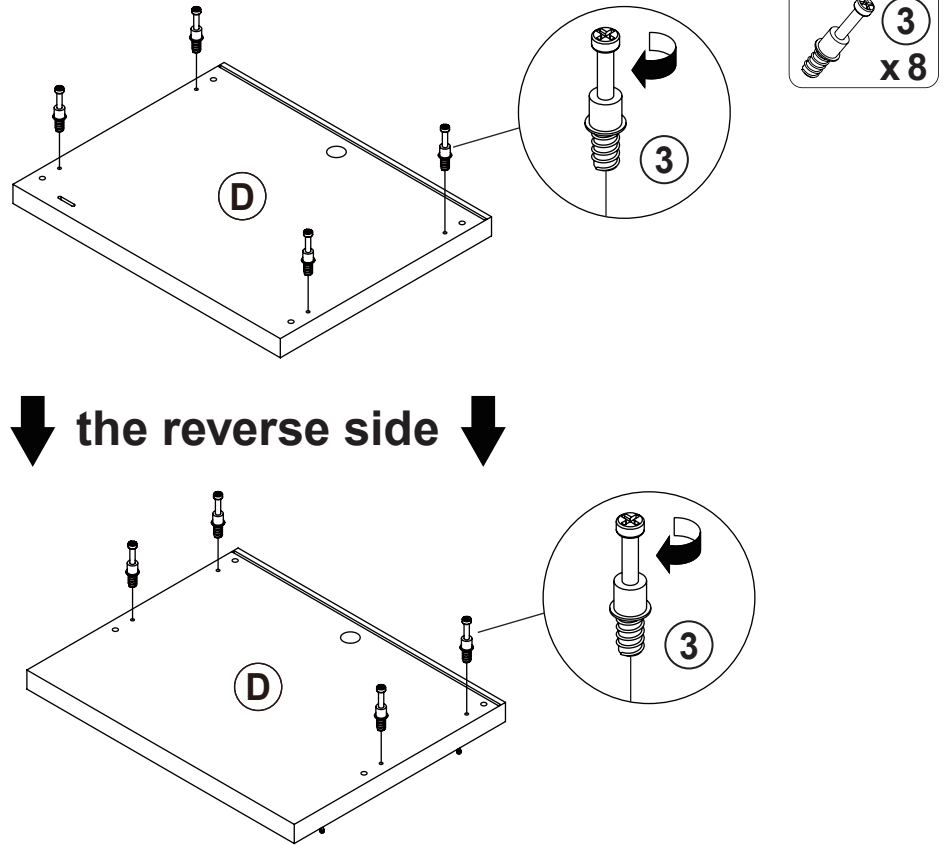

**STEP 4**

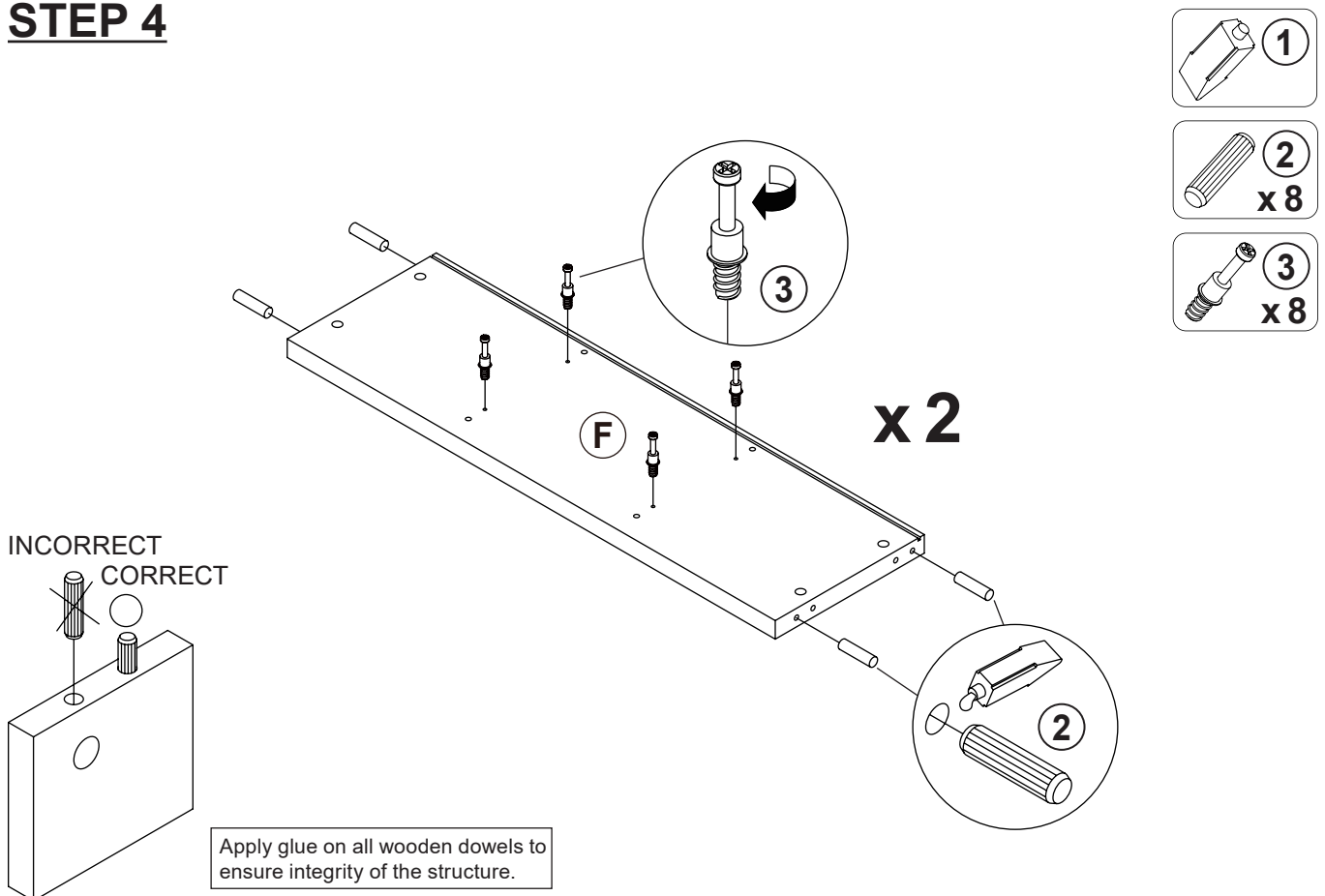

ITEM: 802693

**COASTER**  
FINE FURNITURE

**STEP 5**

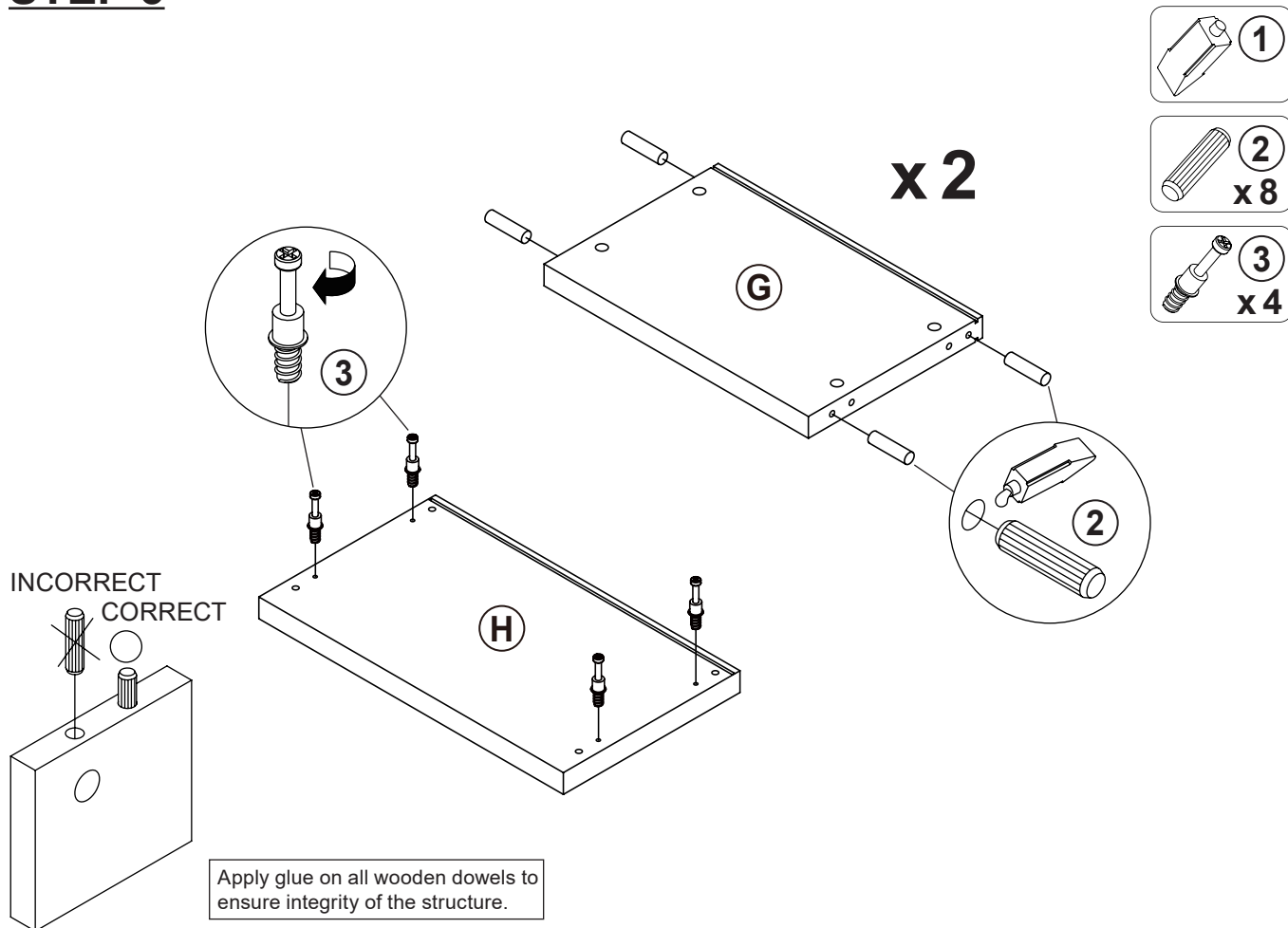

**STEP 6**

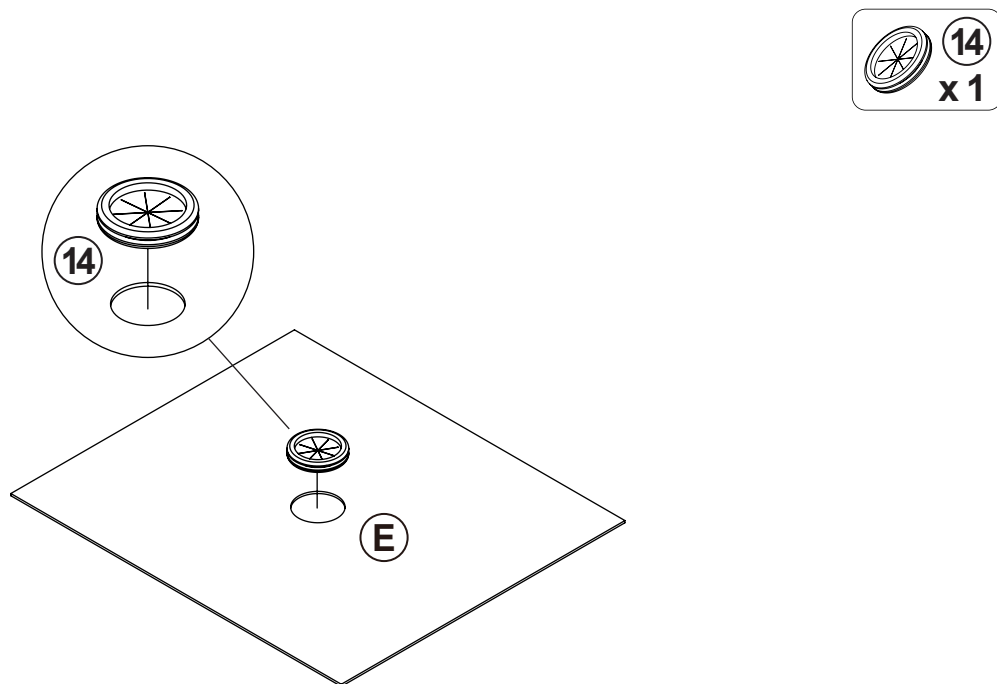

ITEM: 802693

**COASTER**  
FINE FURNITURE

**STEP 7**

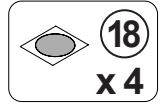
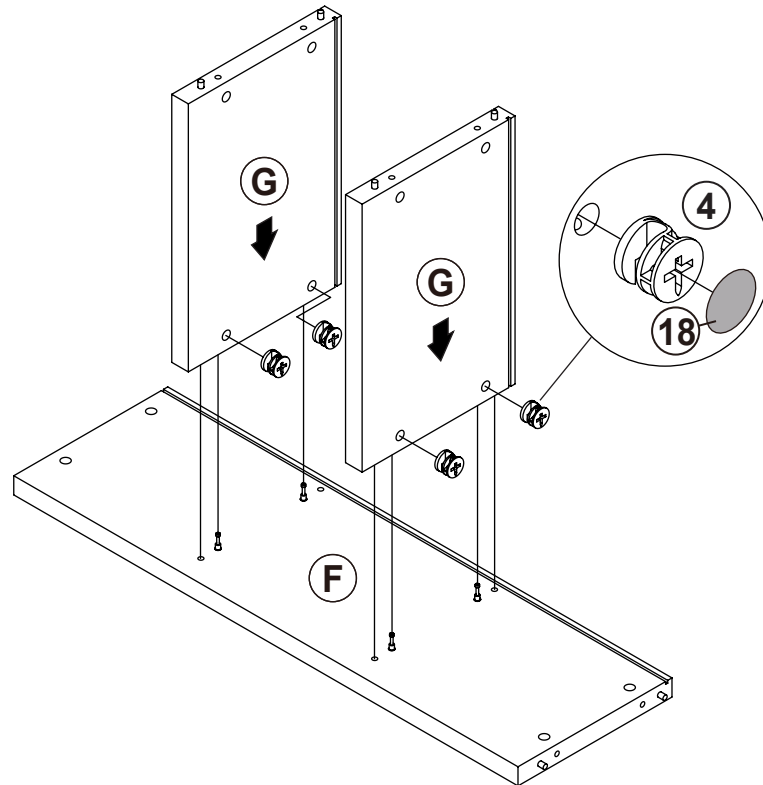

**STEP 8**

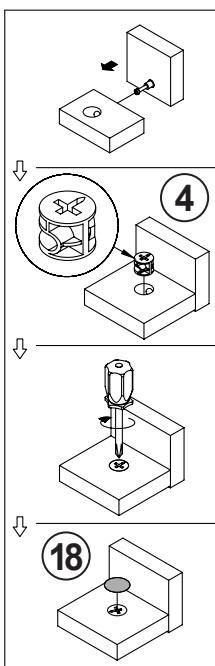
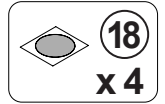
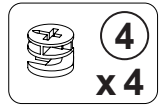
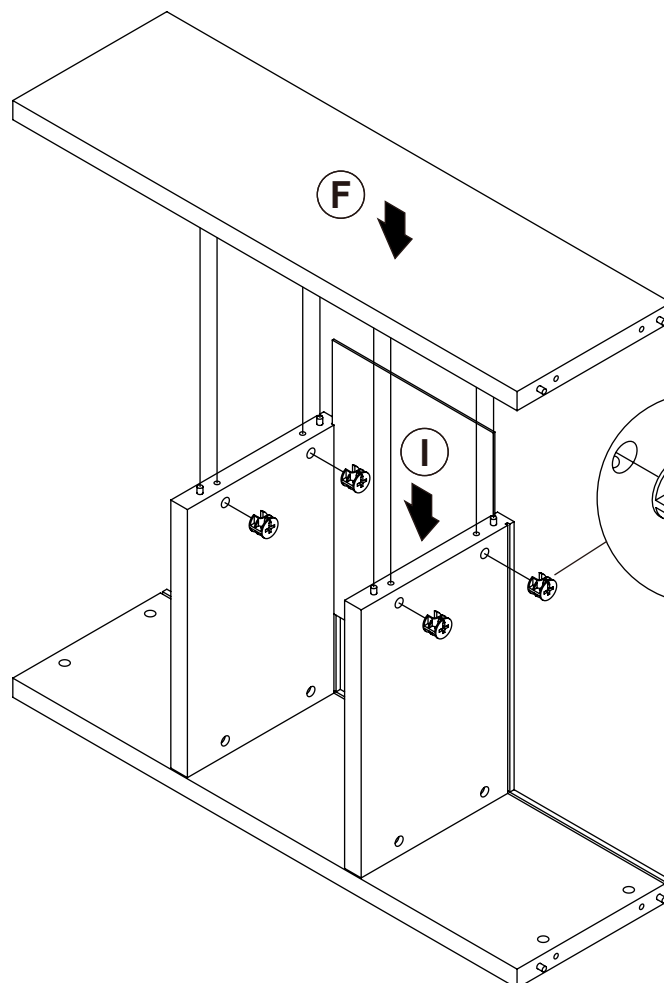

ITEM: 802693

**COASTER**<sup>®</sup>

FINE FURNITURE

**STEP 9**

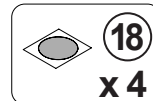
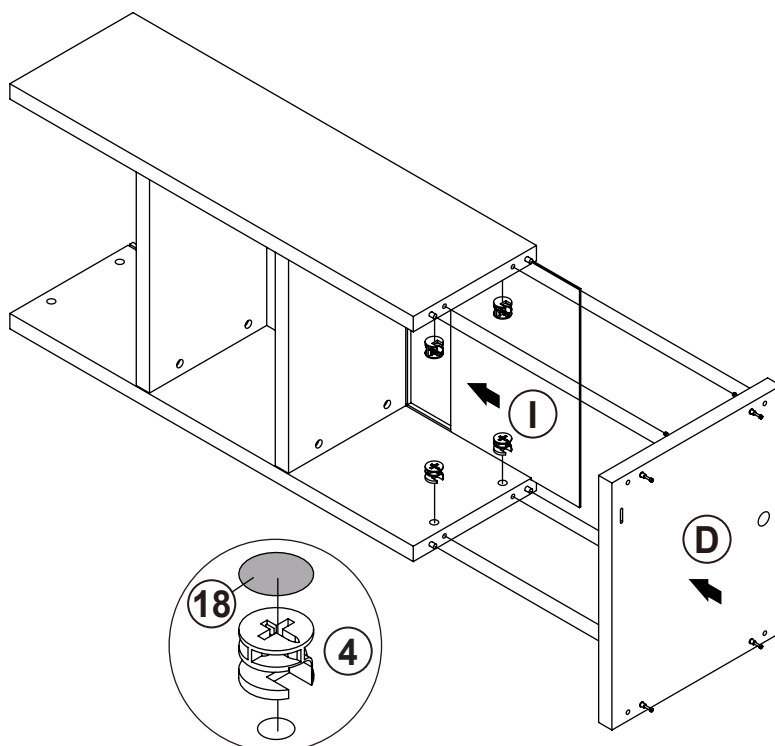
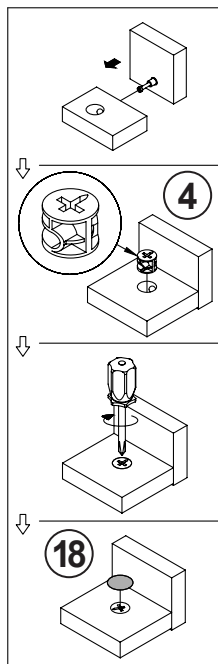
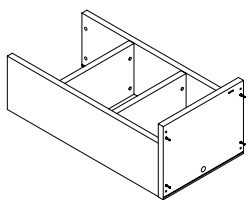

**STEP 10**

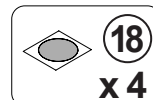
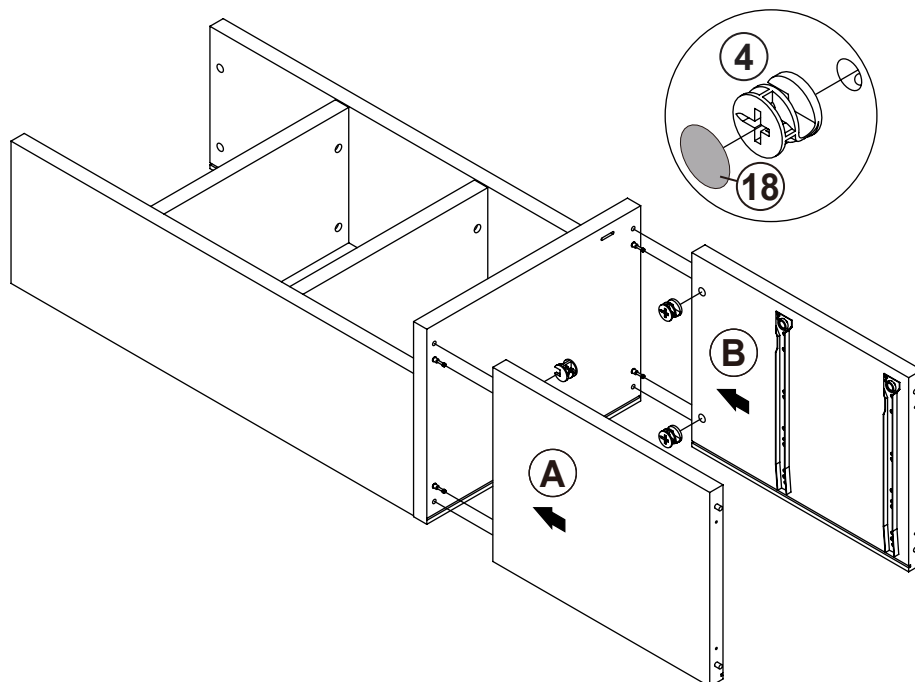

ITEM: **802693**

**COASTER**  
FINE FURNITURE

**STEP 11**

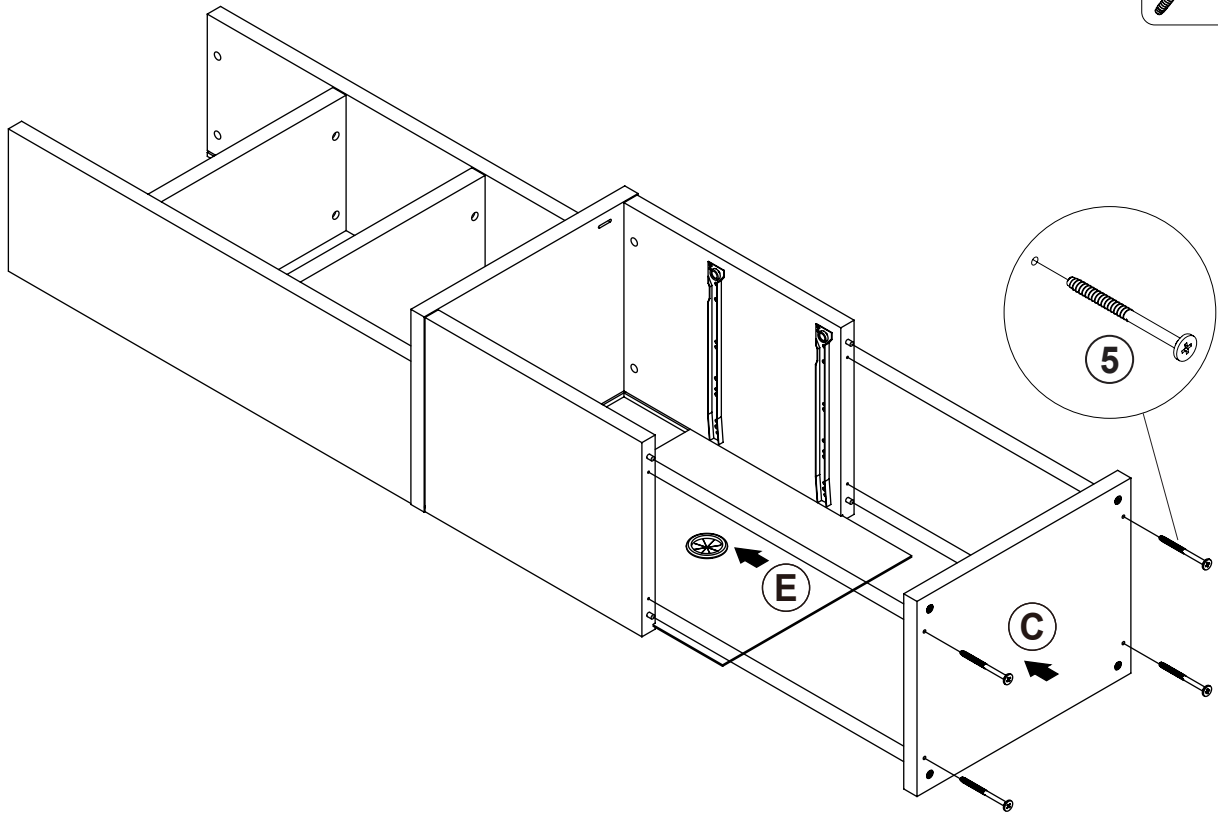
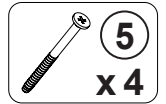

**STEP 12**

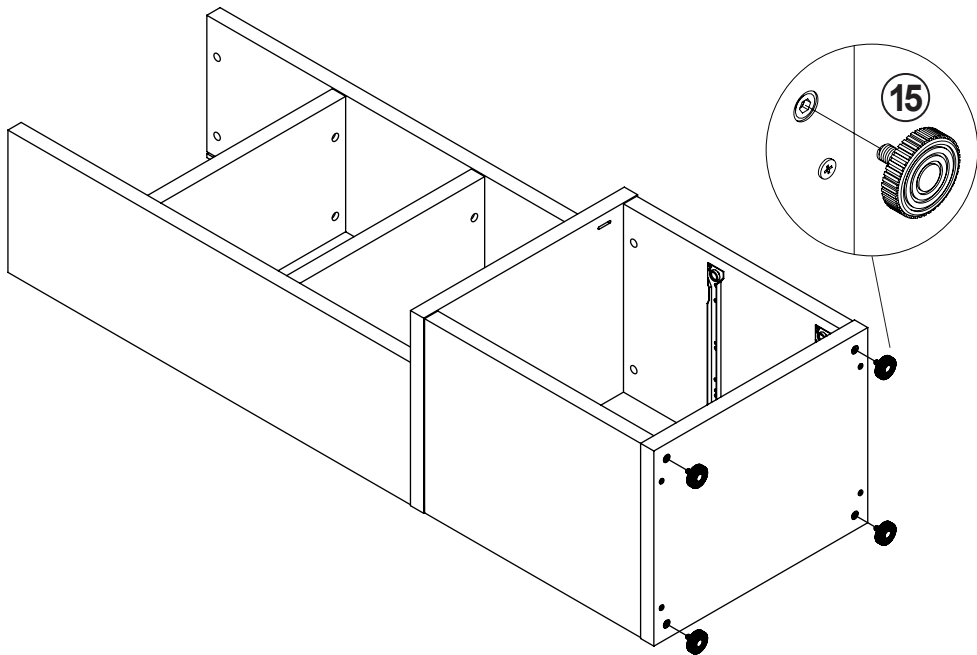
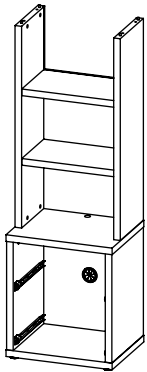
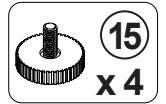

ITEM: 802693

**COASTER**  
FINE FURNITURE

**STEP 13**

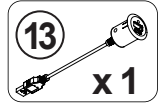
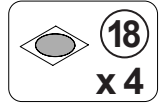
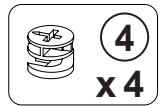
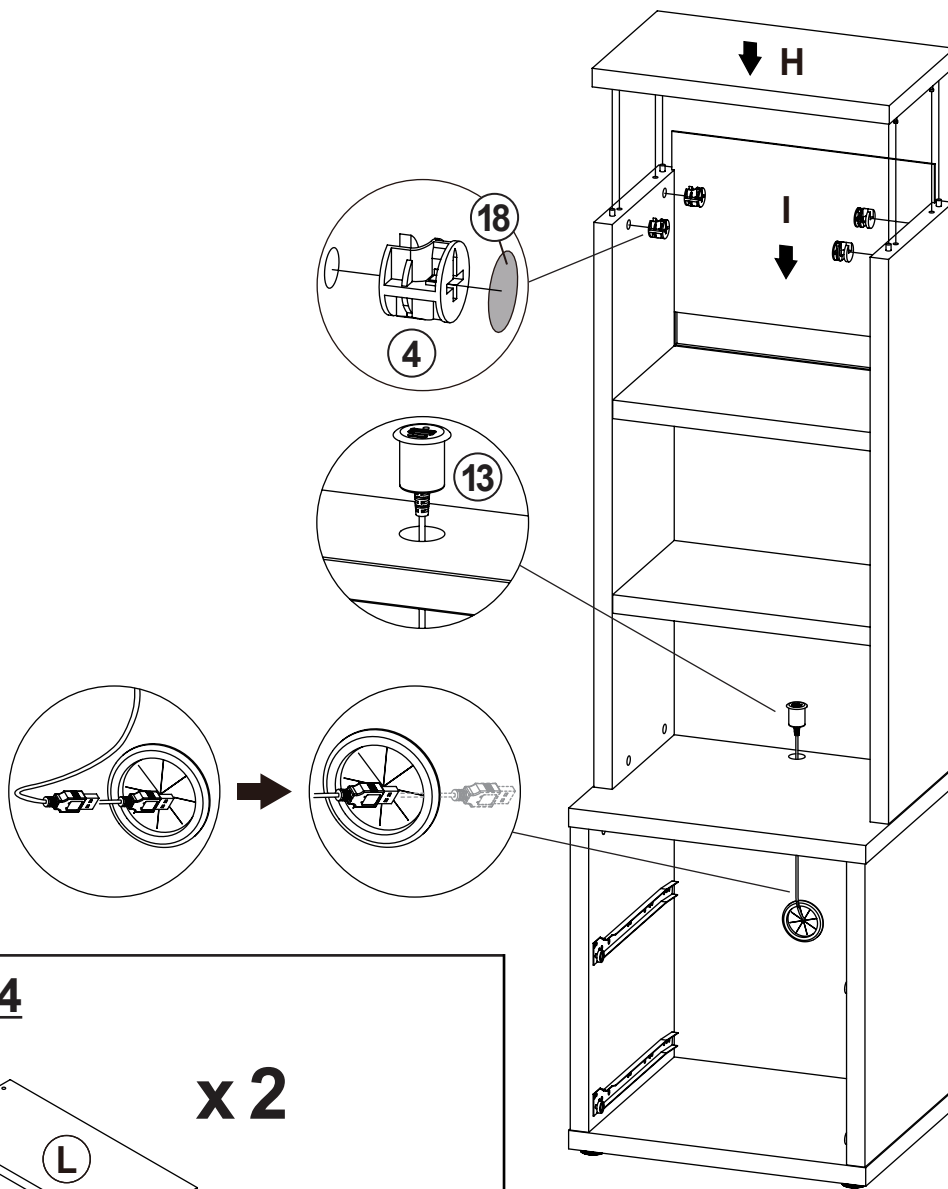

**STEP 14**

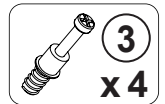
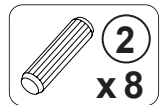
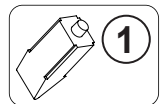
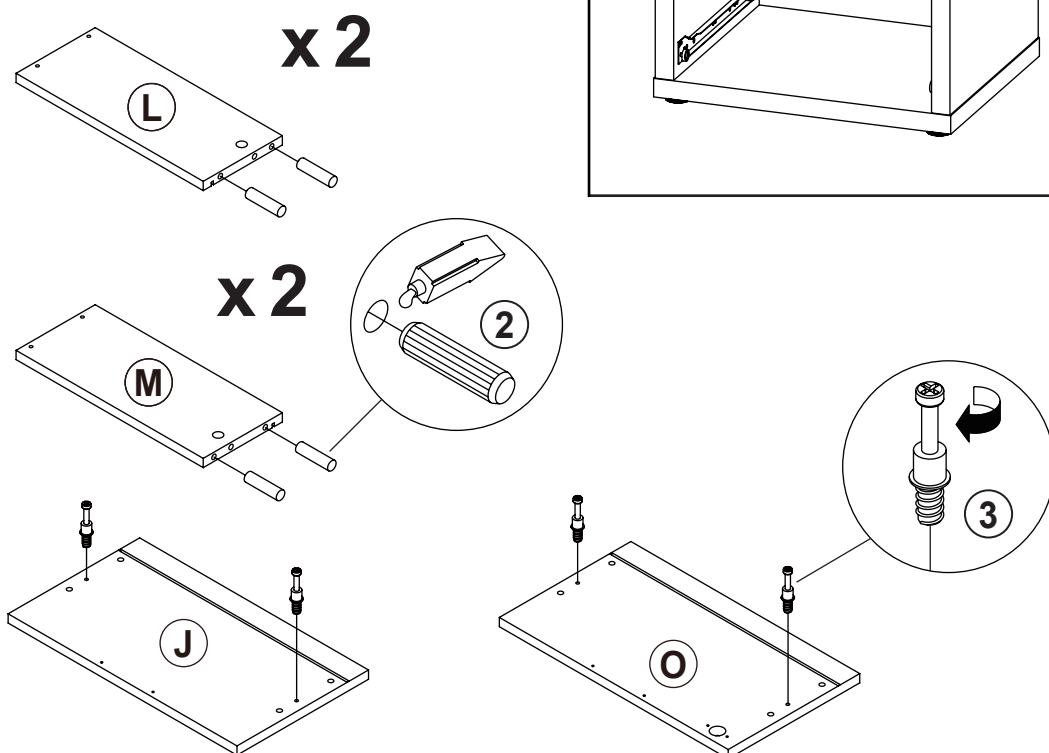

ITEM: 802693

**STEP 15-1**

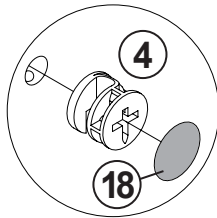
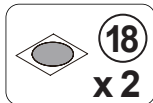
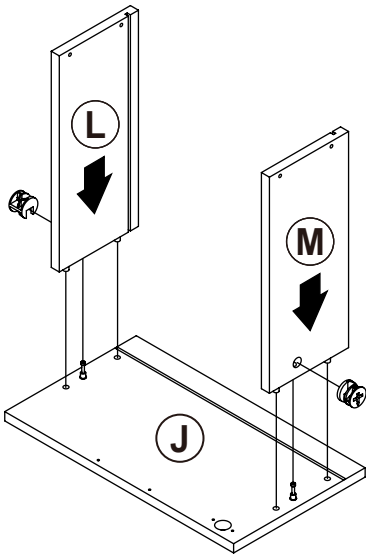

**STEP 15-2**

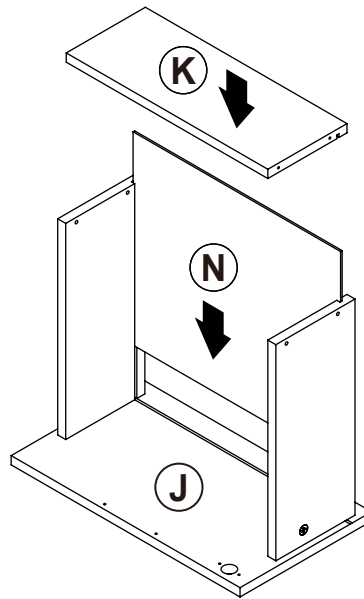

**STEP 15-3**

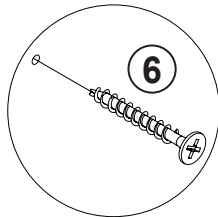
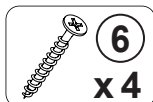
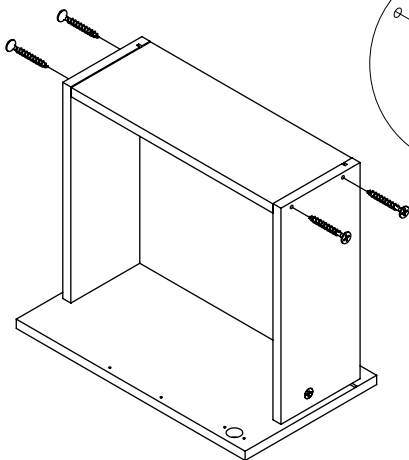

**STEP 15-4**

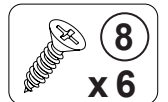
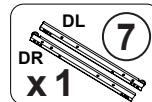
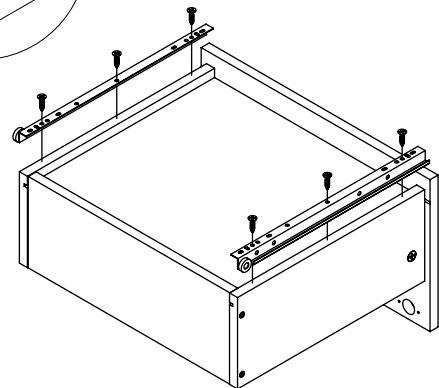
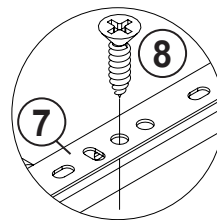

**STEP 15-5**

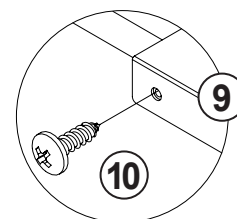
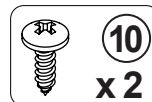
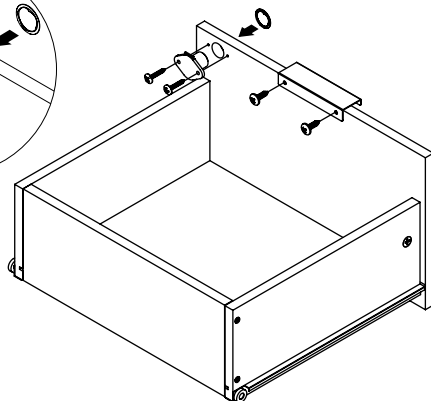
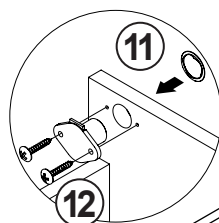

ITEM: 802693

**STEP 16-1**

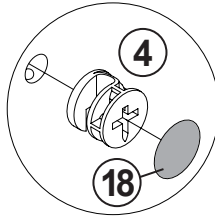
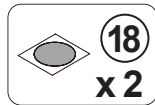
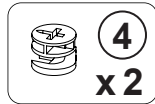
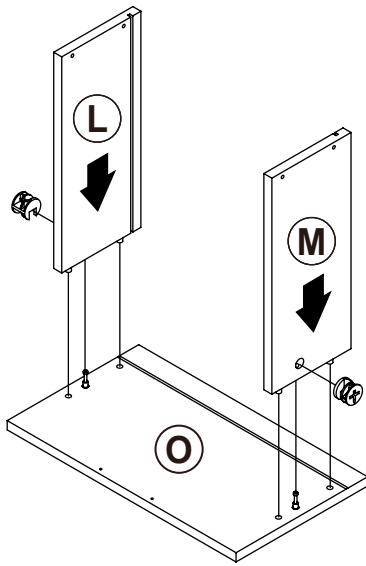

**STEP 16-2**

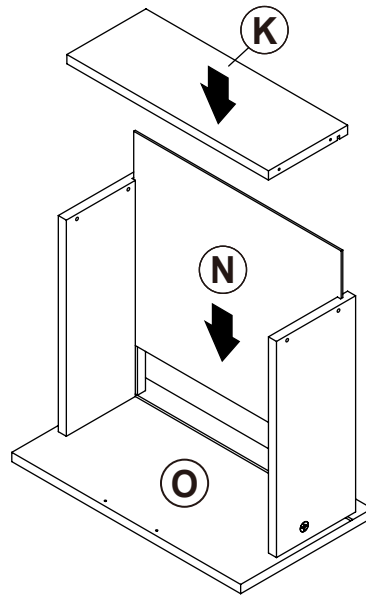

**STEP 16-3**

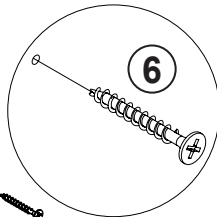
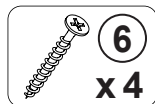
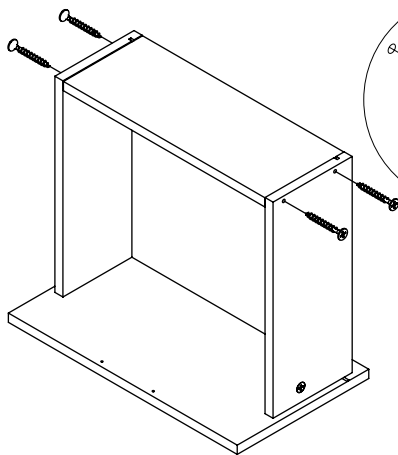

**STEP 16-4**

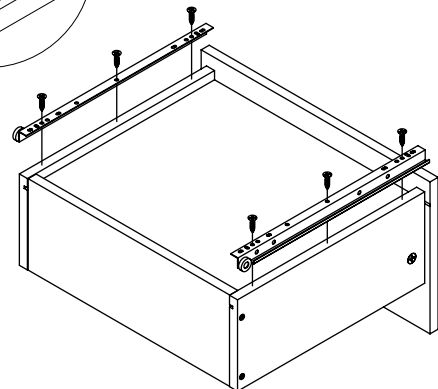
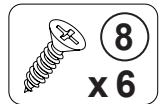
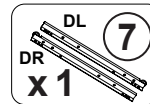
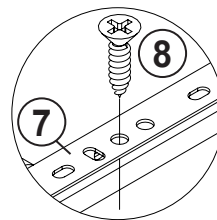

**STEP 16-5**

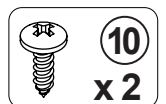
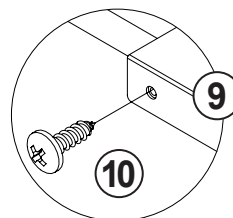
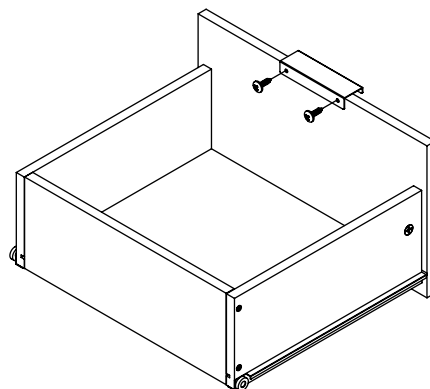

ITEM: 802693

**STEP 17**

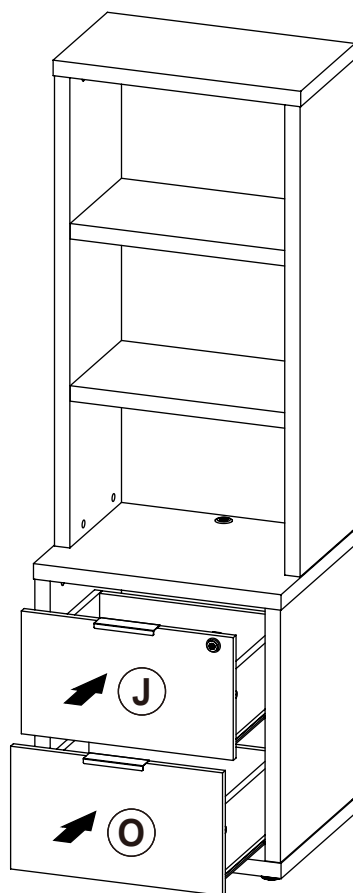

**STEP 18**

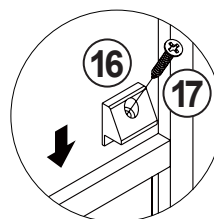
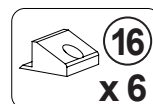
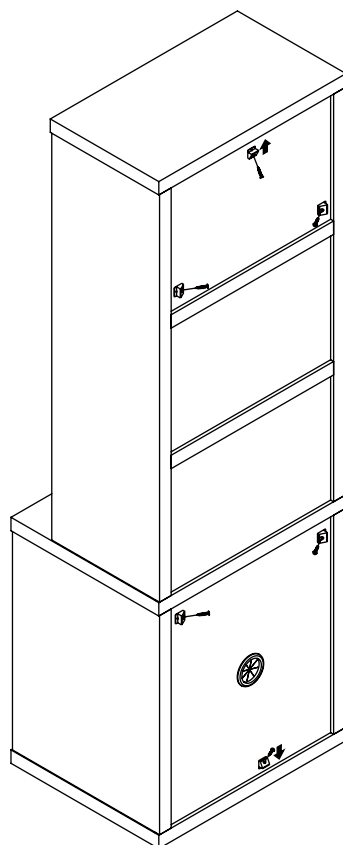

ITEM: **802693**

**STEP 19**

**COMPLETE**

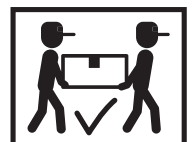
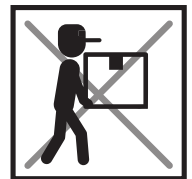
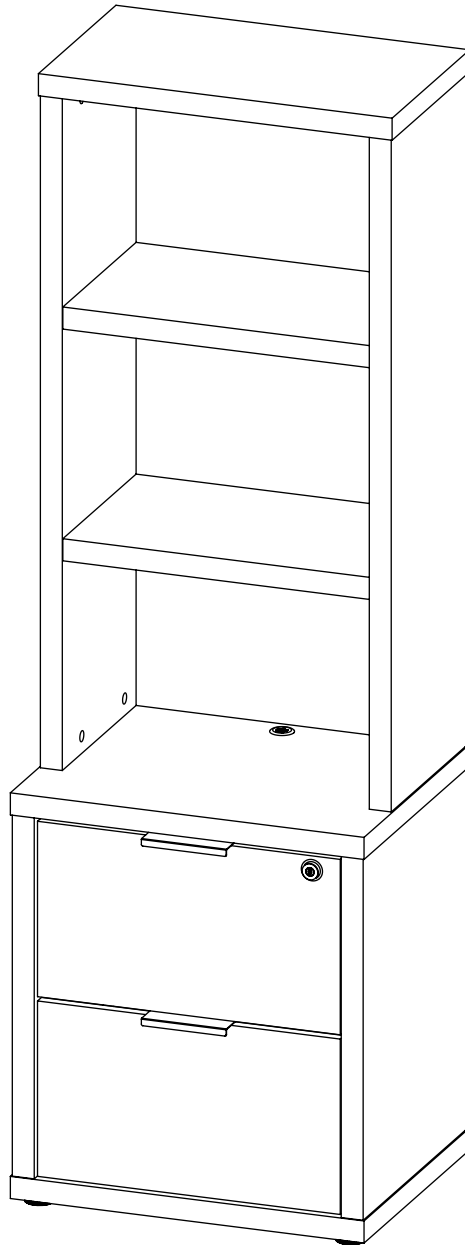

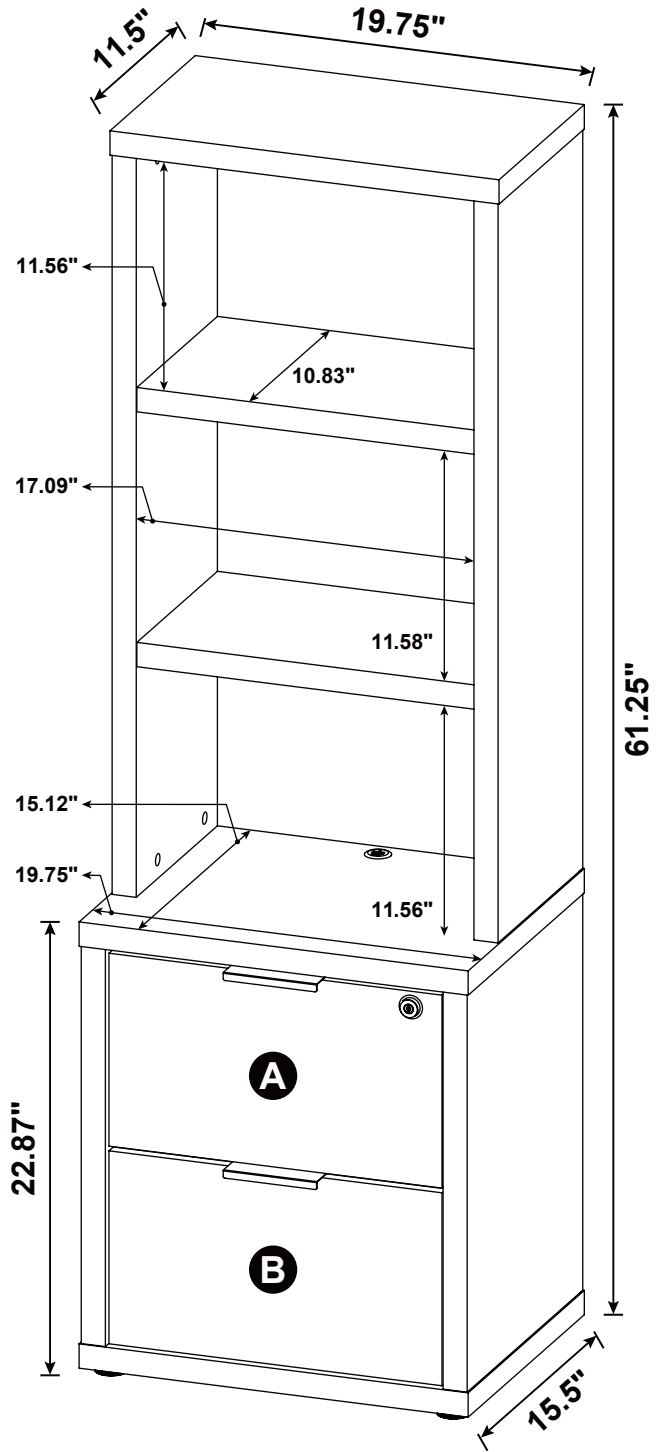
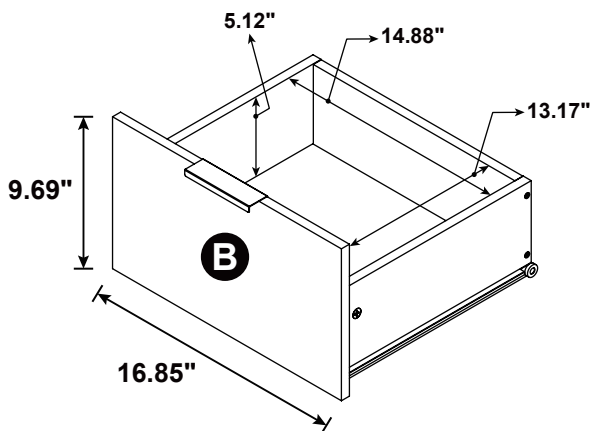
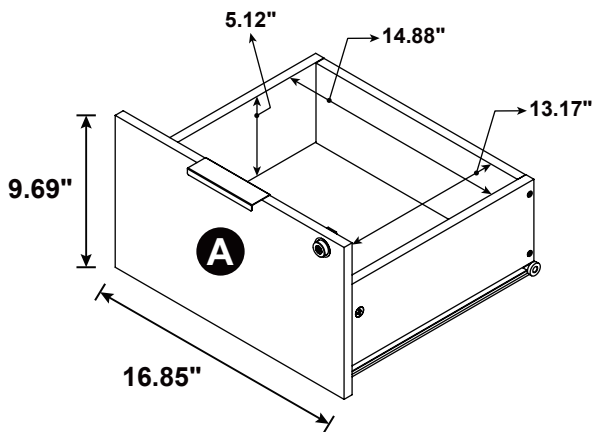

Note : Dimension tolerance  $\pm 5\%$

# ANTI-TIPPING INSTALLMENT INSTRUCTIONS

## FURNITURE TIPPING RESTRAINT

### WARNING

Injury may result from tipping furniture.  
This restraint may protect against tipping furniture.  
Do not allow children to climb on furniture.  
This restraint is not a substitute for proper adult supervision.  
Failure to detach this restraint before moving the furniture may result in injury and damage.

This restraint must be screwed to a wood stud on the wall, using the long screw provided.

### STEP 1

Secure the bracket to the back top of the unit, using the short screw provided, as shown in the drawing.

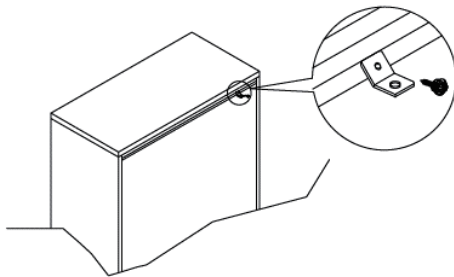

### STEP 2

Locate the wood stud on the wall, and secure the other bracket, 2 inches below the back of the unit.

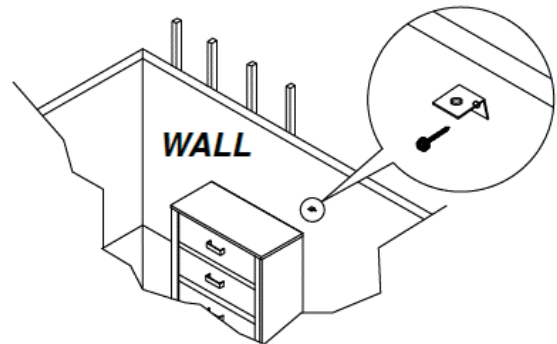

### STEP 3

Place the furniture into position so both mounting brackets are vertically in line. Lace the end of the restraint strap through the larger hole in each mounting bracket. Bring both ends together and slide the flat end through the locking end, and drag it through, until the slack is removed. Ensure that the strap is securely laced and locked.

