

*ASSEMBLY INSTRUCTIONS*  
*COASTER FINE FURNITURE*



*Fine Furniture for every stage of life*

**193820(B1&B2)**  
**Dining Table**

# ITEM: 193820(B1&B2)



## ASSEMBLY INSTRUCTIONS

### ASSEMBLY TIPS:

1. Remove hardware from box and sort by size.
2. Please check to see that all hardware and parts are present prior to start of assembly.
3. Please follow attached instructions in the same sequence as numbered to assure fast & easy assembly.



### WARNING!

1. Don't attempt to repair or modify parts that are broken or defective. Please contact the store immediately.
2. This product is for home use only and not intended for commercial establishments.



ASSEMBLY TIME

15 MINUTES

## PARTS IDENTIFICATION

### B1 (BOX 1)

A TOP

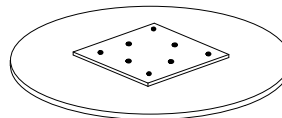

1PC

B MOUNTING PLATE  
(PRE-ATTACHED TO TOP)

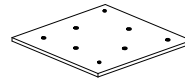

1PC

### B2 (BOX 2)

C LEG WITH LABEL "1"



2PCS

D LEG WITH LABEL "2"

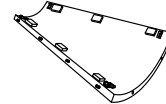

2PCS

## HARDWARE IDENTIFICATION

### Z-B1 (BOX 1) - HARDWARE PACK IS LOCATED IN 193820 (B1)

1 ALLEN WRENCH  
(M4 X 60MM - RBW)



1PC

2 BOLT  
(M6 X 30MM - RBW)



4PCS

3 LOCK WASHER  
(M6 X 30MM - RBW)



4PCS

4 FLAT WASHER  
(M6 X 30MM - RBW)



4PCS

5 WOOD DOWEL  
(M8 X 30MM)



14PCS

6 LEVELER



8PCS

# ITEM: 193820(B1&B2)



## ASSEMBLY INSTRUCTIONS

### STEP 1

Attention! Please remove part B and all hardware from TOP (A), using ALLEN WRENCH (1) and keep for STEP 6 and STEP 7.

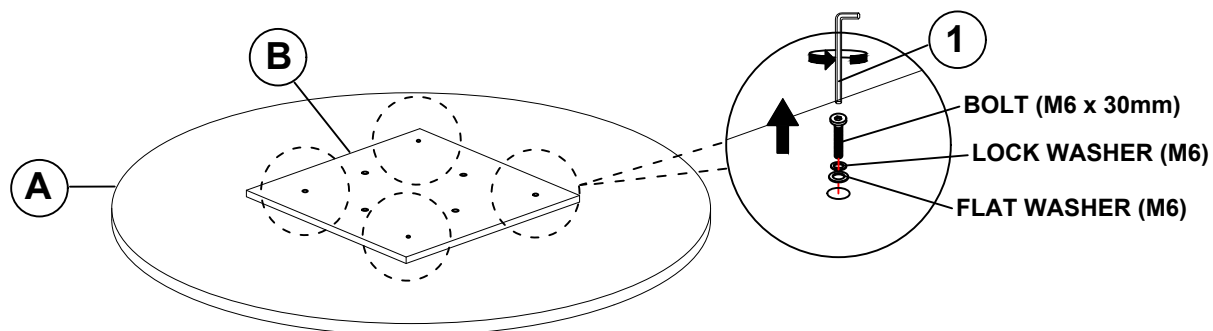

### STEP 2

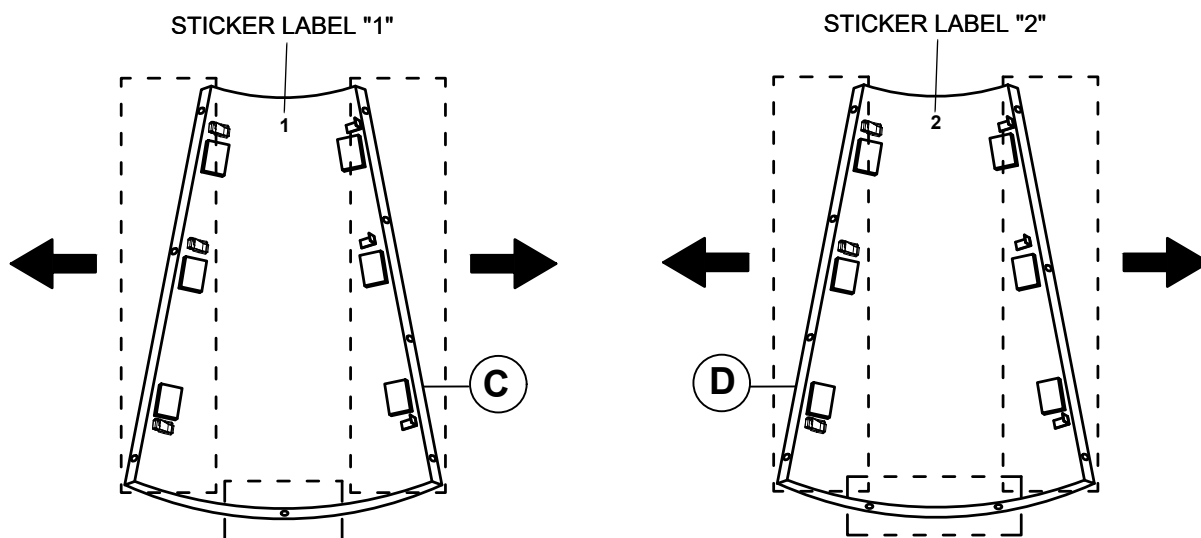

### STEP 3

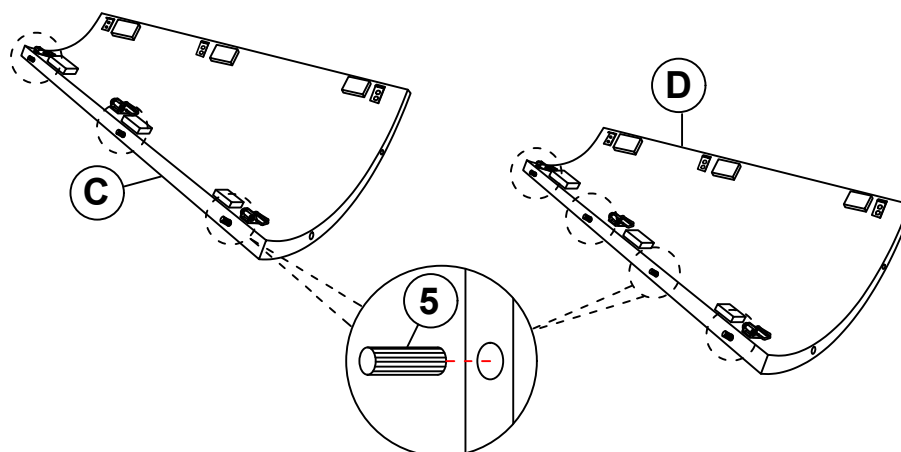

# ITEM: 193820(B1&B2)

## ASSEMBLY INSTRUCTIONS



### STEP 4

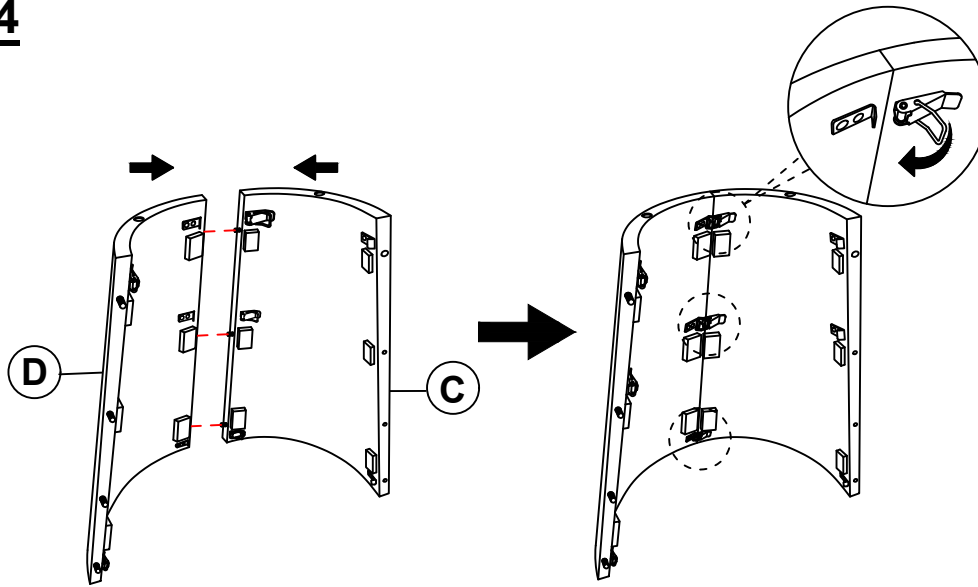

### STEP 5

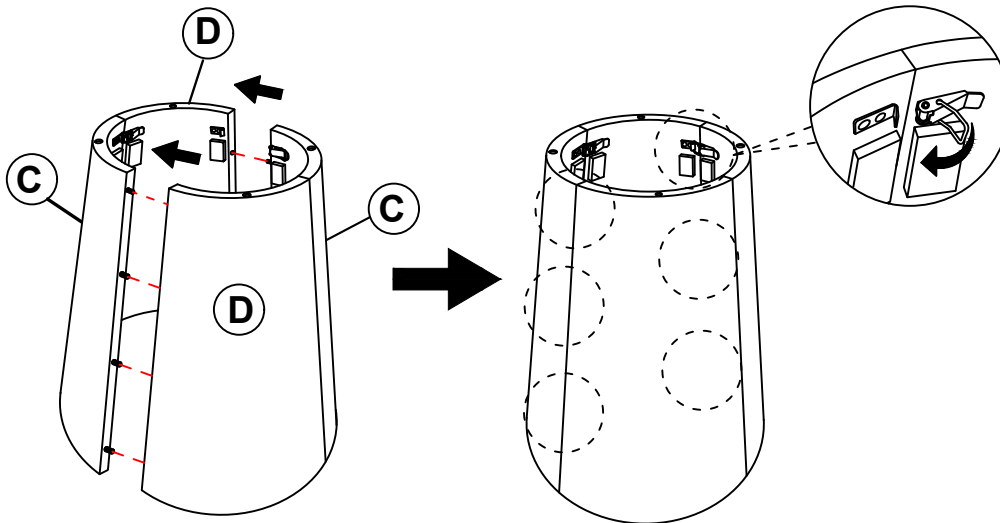

### STEP 6

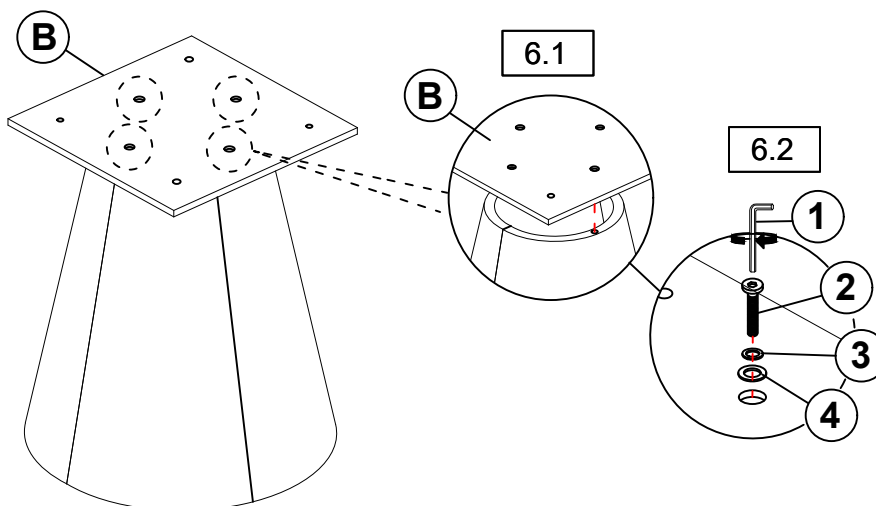

# ITEM: 193820(B1&B2)

## ASSEMBLY INSTRUCTIONS

### STEP 7

Attention! Use hardware from STEP 1 for this STEP.

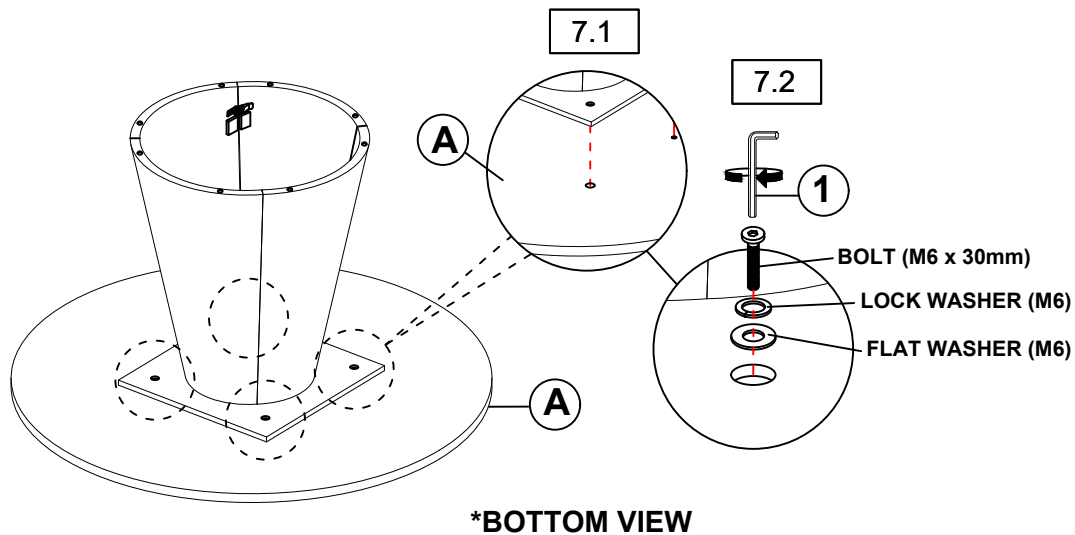

### STEP 8

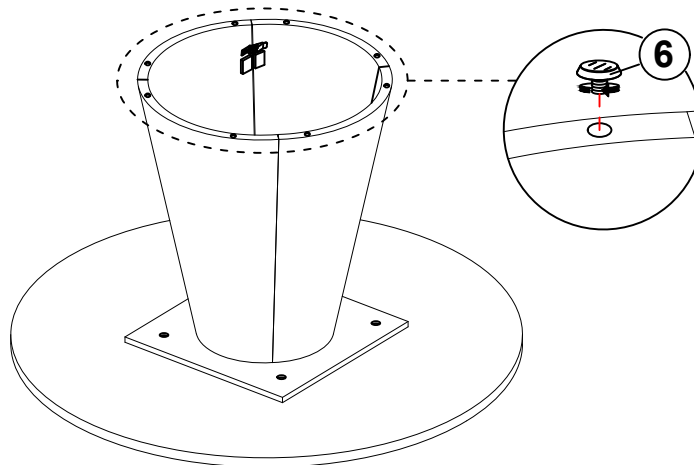

### STEP - COMPLETE

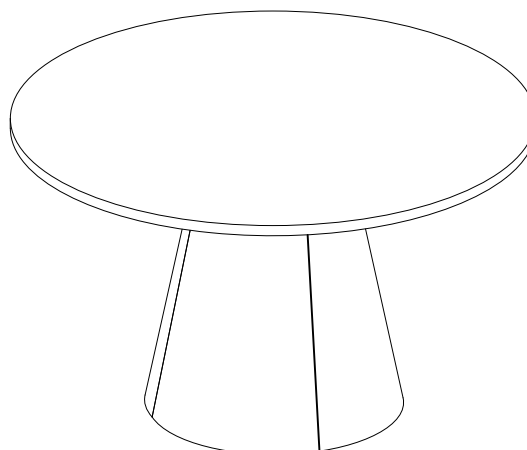

ITEM: **193820(B1&B2)**

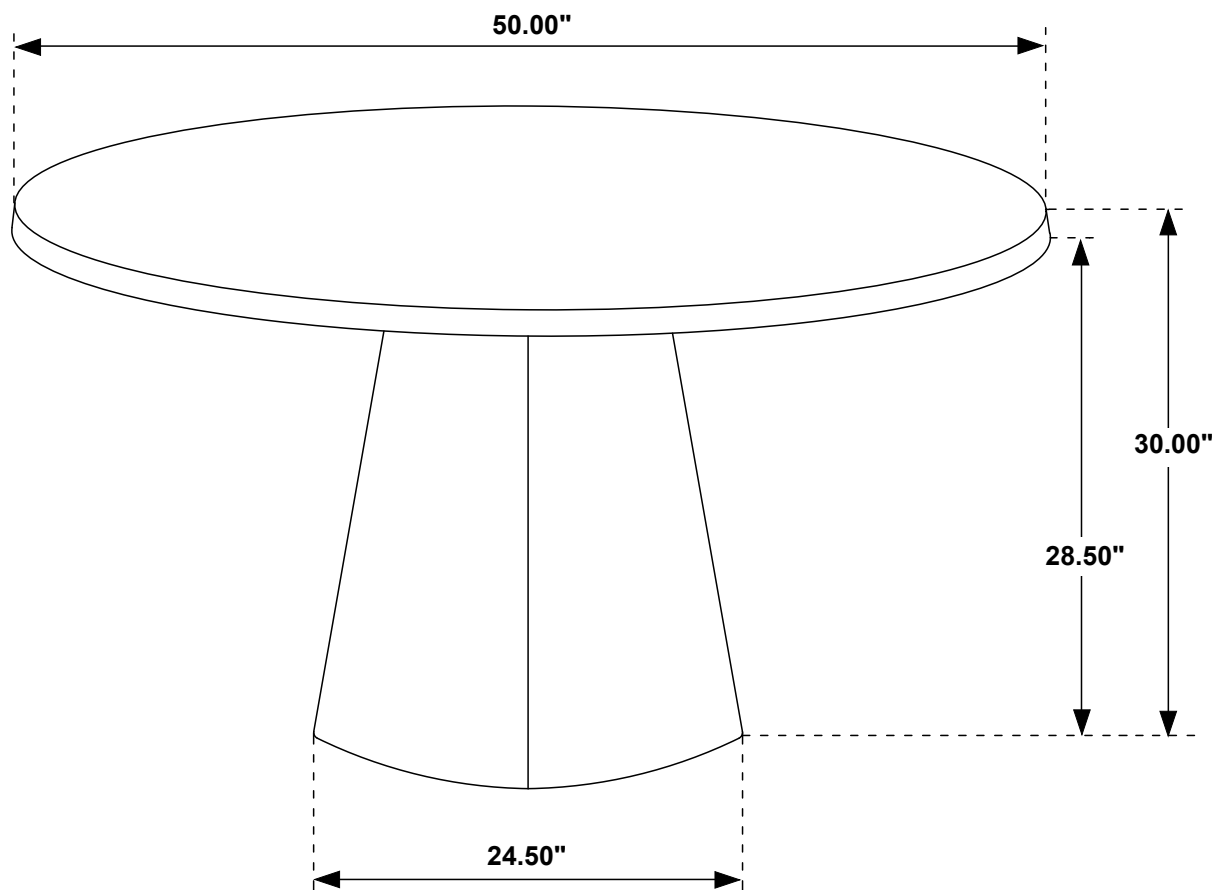

**Note: Dimension tolerance  $\pm 5\%$**

**ASSEMBLY INSTRUCTIONS**  
**COASTER FINE FURNITURE**



*Fine Furniture for every stage of life*

**193822**  
**Side Chair**

ITEM: **193822**

## ASSEMBLY INSTRUCTIONS

### ASSEMBLY TIPS:

1. Remove hardware from box and sort by size.
2. Please check to see that all hardware and parts are present prior to start of assembly.
3. Please follow attached instructions in the same sequence as numbered to assure fast & easy assembly.



### WARNING!

1. Don't attempt to repair or modify parts that are broken or defective. Please contact the store immediately.
2. This product is for home use only and not intended for commercial establishments.



ASSEMBLY TIME

15 MINUTES

## PARTS IDENTIFICATION

A SEAT AND BACK

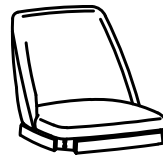

1PC

B FRONT LEG

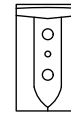
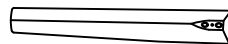

2PCS

C BACK LEG

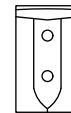
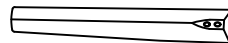

2PCS

## HARDWARE IDENTIFICATION

1 ALLEN WRENCH  
(M4 X 60MM - RBW)



1PC

2 LONG BOLT  
(M6 X 60MM - RBW)



8PCS

3 LOCK WASHER  
(M6 X 13MM - RBW)



8PCS

4 FLAT WASHER  
(M6 X 19MM - RBW)



8PCS

ITEM: **193822**

**ASSEMBLY INSTRUCTIONS**



**STEP 1**

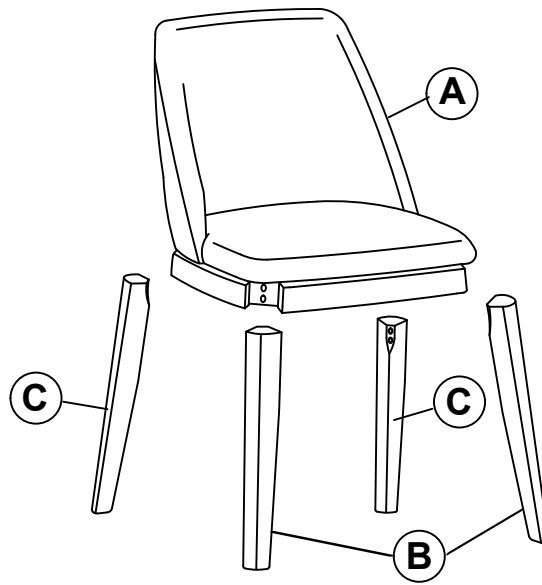

**STEP 2**

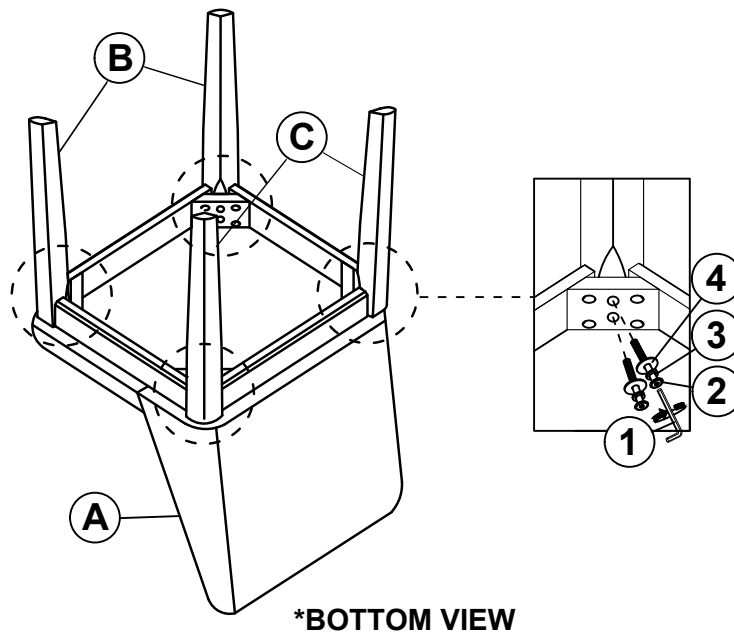

**STEP 3**  
**COMPLETE**

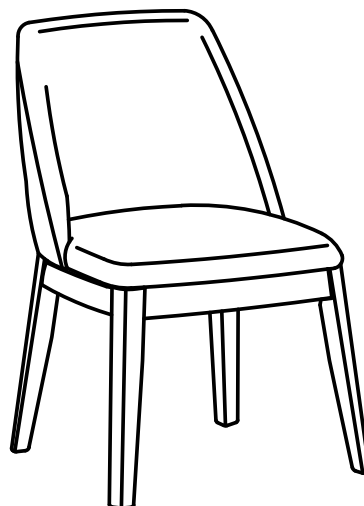

ITEM: 193822

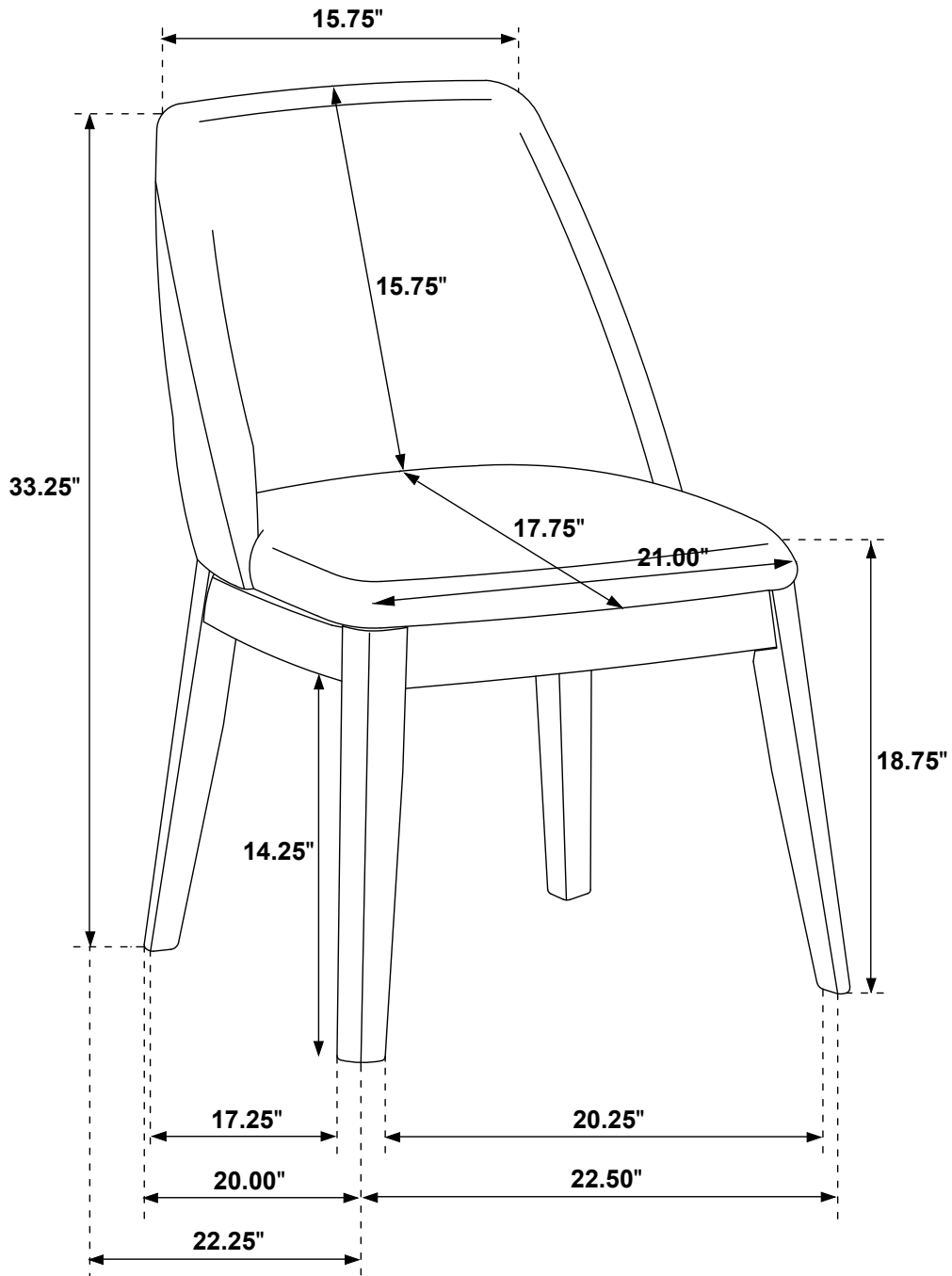

Note : Dimension tolerance  $\pm 5\%$