

ASSEMBLY INSTRUCTIONS
COASTER FINE FURNITURE



Fine Furniture for every stage of life

315914Q(B1&B2)
Queen Bed

ITEM: 315914Q(B1&B2)



ASSEMBLY INSTRUCTIONS

ASSEMBLY TIPS:

1. Remove hardware from box and sort by size.
2. Please check to see that all hardware and parts are present prior to start of assembly.
3. Please follow attached instructions in the same sequence as numbered to assure fast & easy assembly.



WARNING!

1. Don't attempt to repair or modify parts that are broken or defective. Please contact the store immediately.
2. This product is for home use only and not intended for commercial establishments.



ASSEMBLY TIME

20 MINUTES

PARTS IDENTIFICATION

B1 (BOX 1)

A HEADBOARD
PANEL

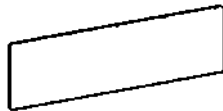

1PC

B FOOTBOARD
PANEL



1PC

C LEFT HEADBOARD
LEG (WITH "L" LABEL)



1PC

D RIGHT HEADBOARD
LEG (WITH "R" LABEL)



1PC

E LEFT FOOTBOARD
LEG (WITH "L" LABEL)

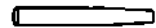

1PC

F RIGHT FOOTBOARD
LEG (WITH "R" LABEL)



1PC

B2 (BOX 1)

G HEADBOARD TOP
RAIL

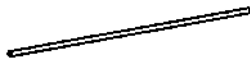

2PCS

H FOOTBOARD
BOTTOM RAIL

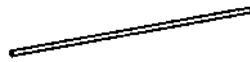

1PC

I BED RAIL



2PCS

J ROLL SLAT
(6PCS)



2SETS

K CENTER RAIL



1PC

L CENTER RAIL SUPPORT
WITH LEVELER



4PCS

NOTE:

Phillips head screw driver is required in the assembly process; however, manufacturer does not provided this item.

ITEM: 315914Q(B1&B2)

ASSEMBLY INSTRUCTIONS

ASSEMBLY TIPS:

1. Remove hardware from box and sort by size.
2. Please check to see that all hardware and parts are present prior to start of assembly.
3. Please follow attached instructions in the same sequence as numbered to assure fast & easy assembly.













WARNING!

1. Don't attempt to repair or modify parts that are broken or defective. Please contact the store immediately.
2. This product is for home use only and not intended for commercial establishments.

HARDWARE IDENTIFICATION

Z-B2 (BOX 2) - HARDWARE PACK IS LOCATED IN 315914Q(B2)

1	SHORT BOLT (M6 x 30mm - BLK)		19PCS	7	FLAT HEAD SCREW (M4 x 25mm - BLK)		8PCS
2	LONG BOLT (M6 x 40mm - BLK)		6PCS	8	ALLEN WRENCH (M4 x 100mm - RBW)		1PC
3	THREADED BOLT (M6 x 60mm - RBW)		8PCS	9	FLAT WASHER (1/4" x 19 Ø - BLK)		19PCS
4	HEX NUT (M6 - RBW)		8PCS	10	LOCK WASHER (1/4" x 12 Ø - BLK)		19PCS
5	HALF ROUND NUT (Ø7.5mm - RBW)		8PCS	11	WRENCH (M6 x 10mm - RBW)		1PC
6	U-SQUARE WASHER (M8 x16 x 25mm - RBW)		8PCS				

NOTE:

Phillips head screw driver is required in the assembly process; however, manufacturer does not provided this item.

ITEM: 315914Q(B1&B2)

ASSEMBLY INSTRUCTIONS



STEP 1

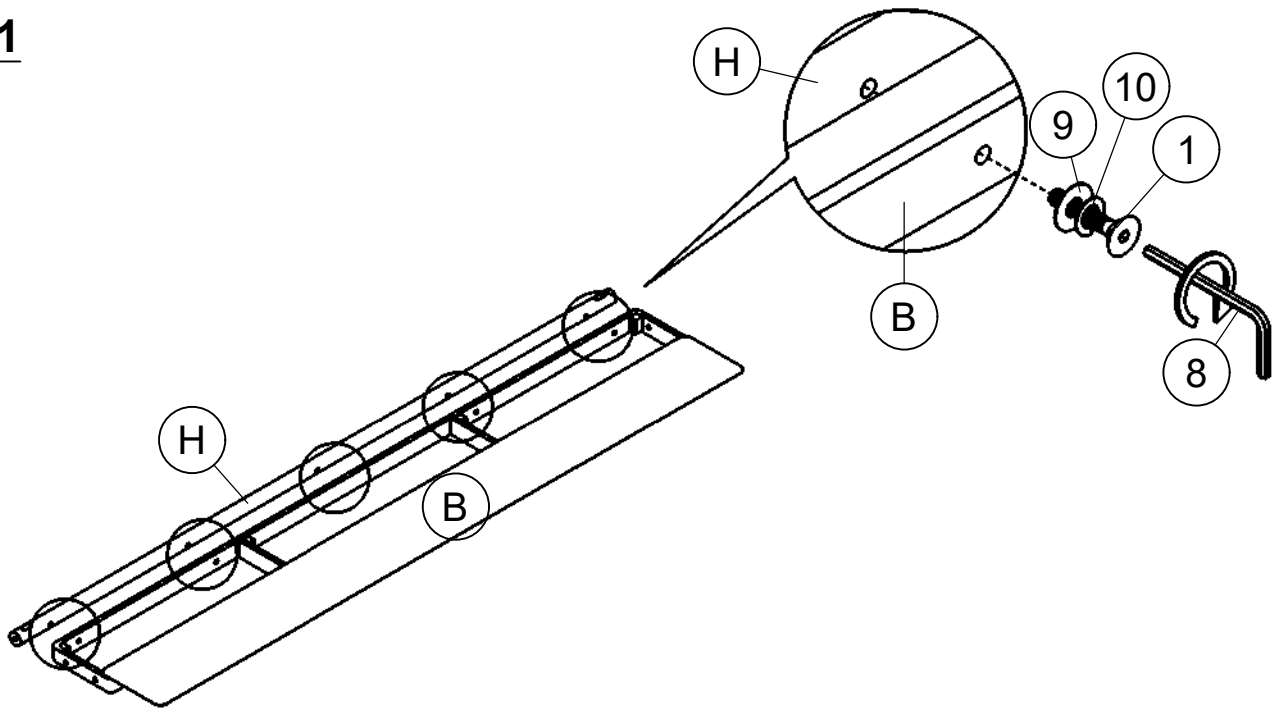

STEP 2

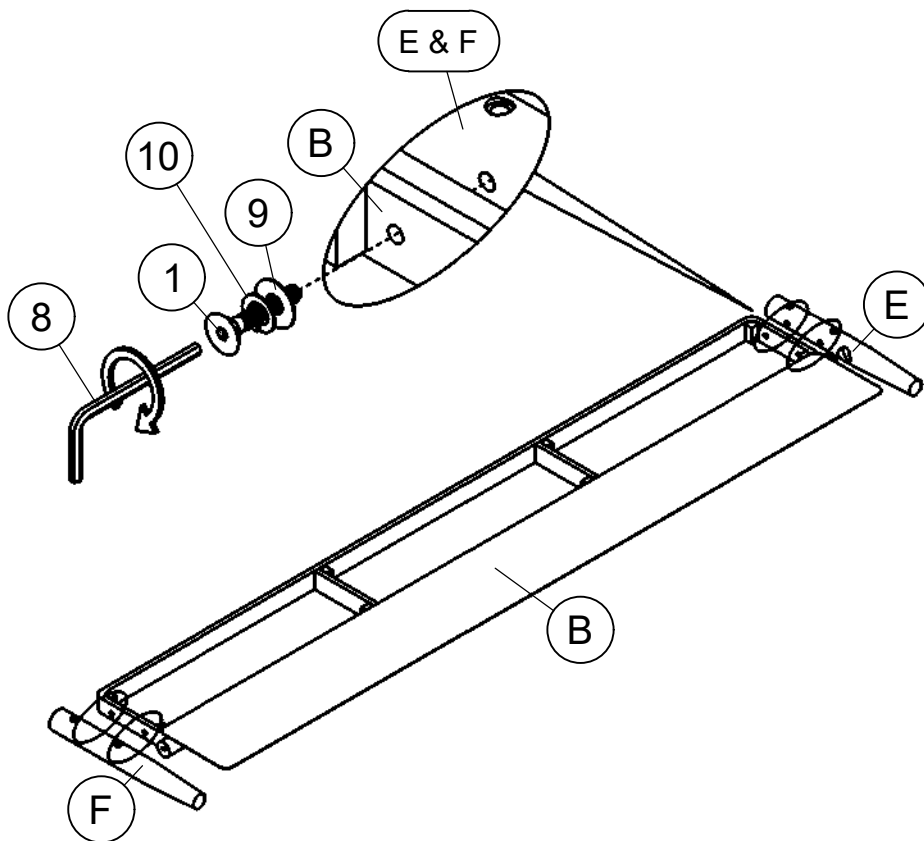

ITEM: 315914Q(B1&B2)

ASSEMBLY INSTRUCTIONS



STEP 3

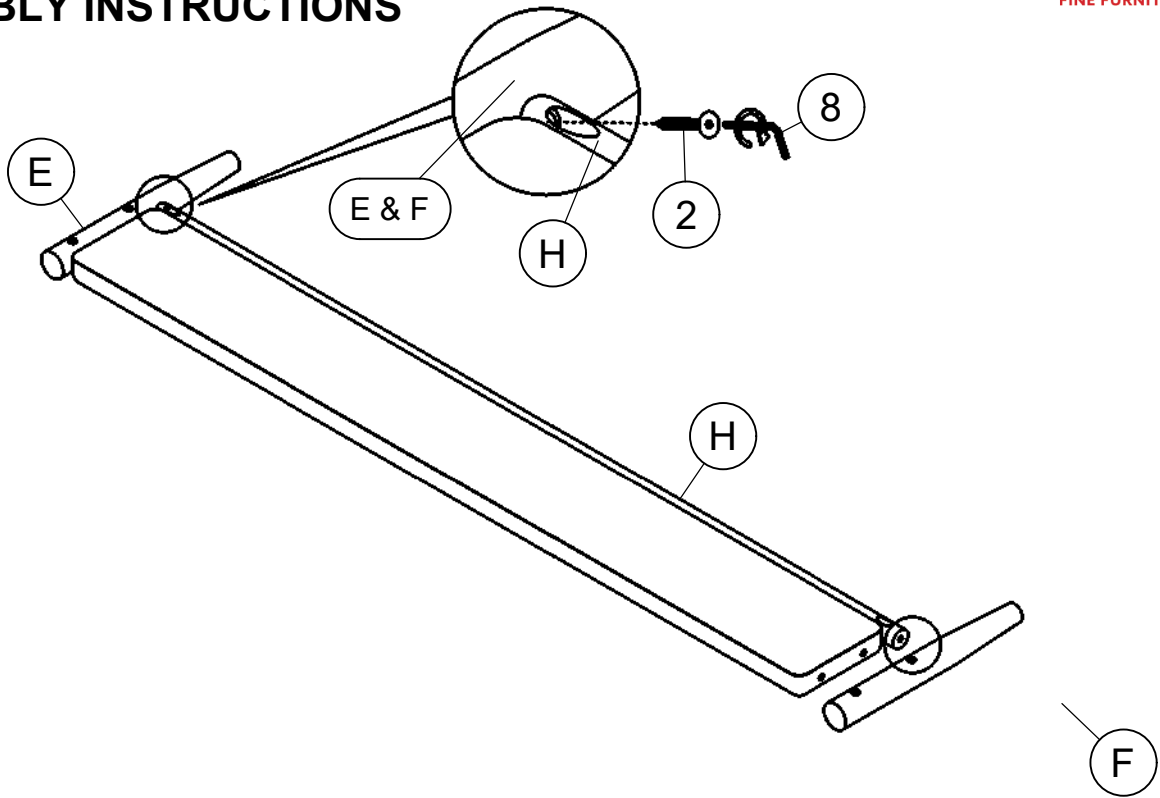

STEP 4

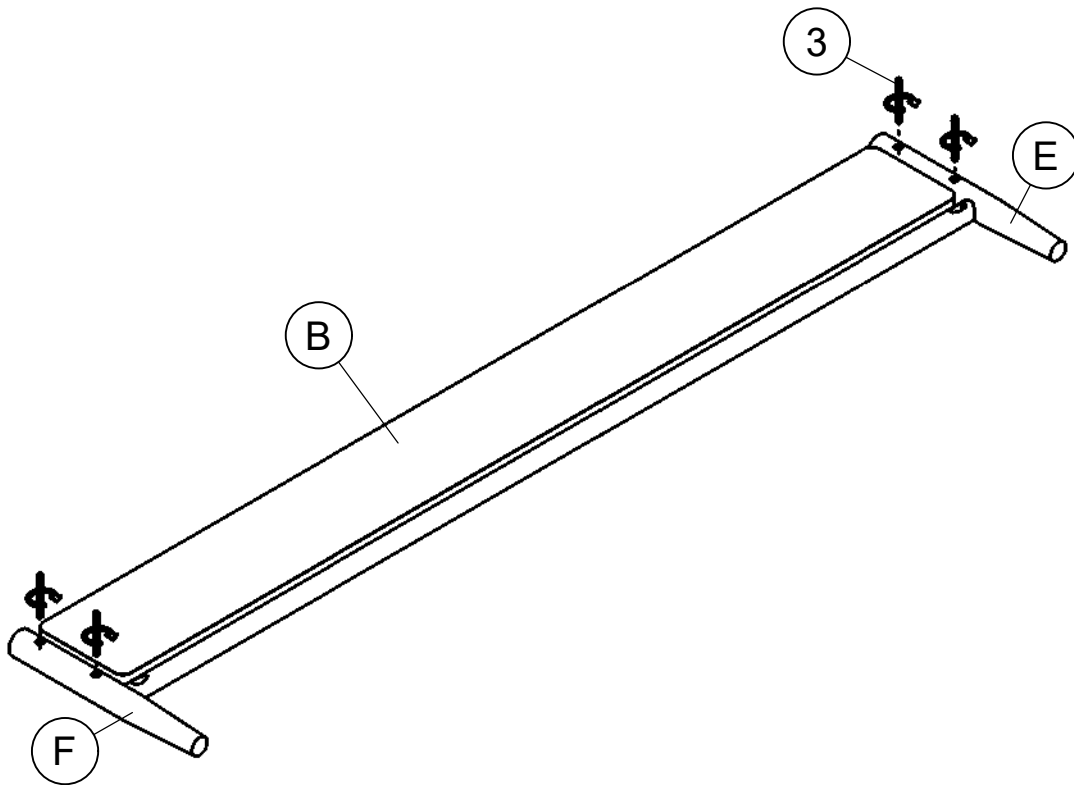

ITEM: 315914Q(B1&B2)

ASSEMBLY INSTRUCTIONS



STEP 5

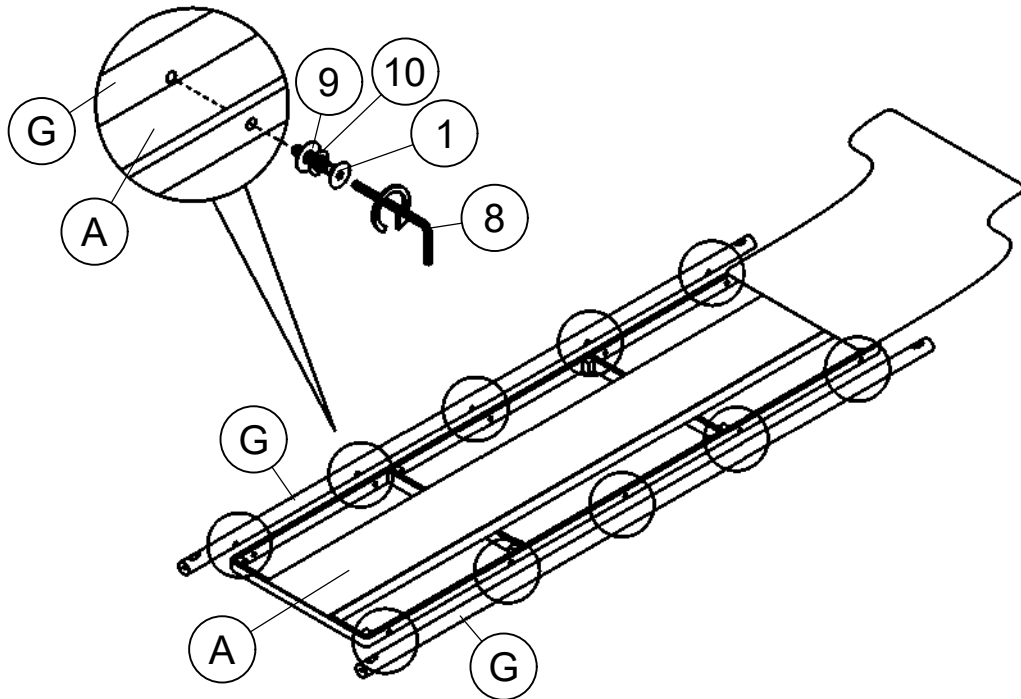

STEP 6

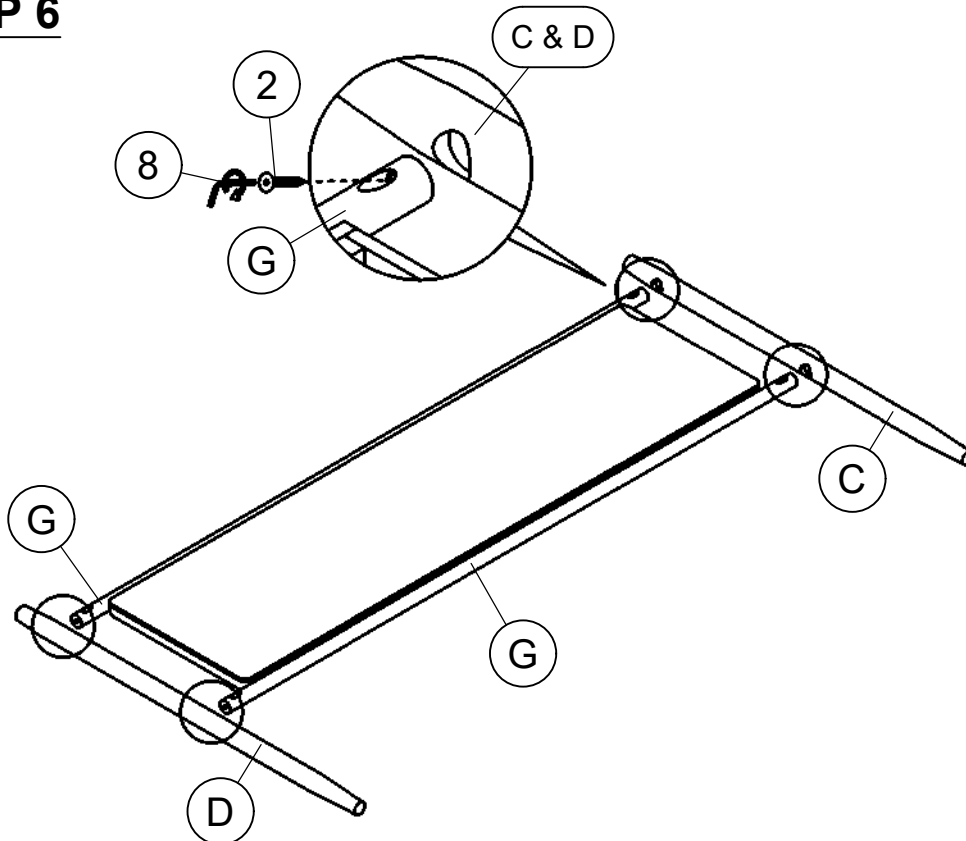

ITEM: 315914Q(B1&B2)

ASSEMBLY INSTRUCTIONS



STEP 7

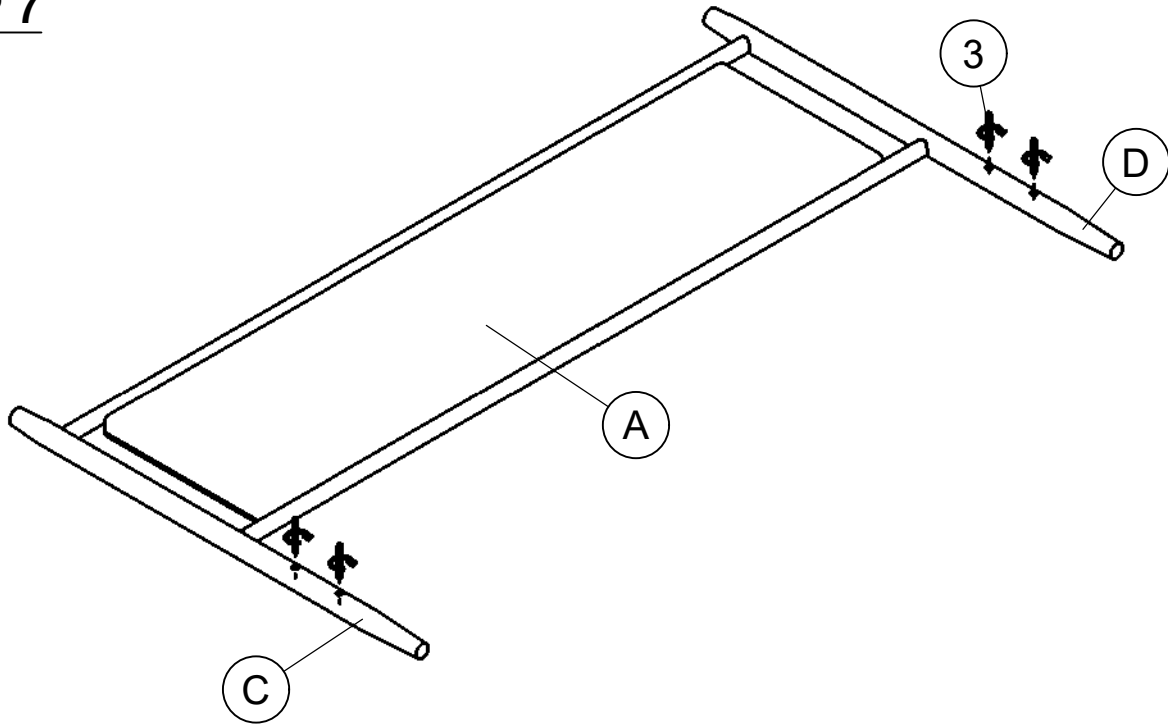

STEP 8

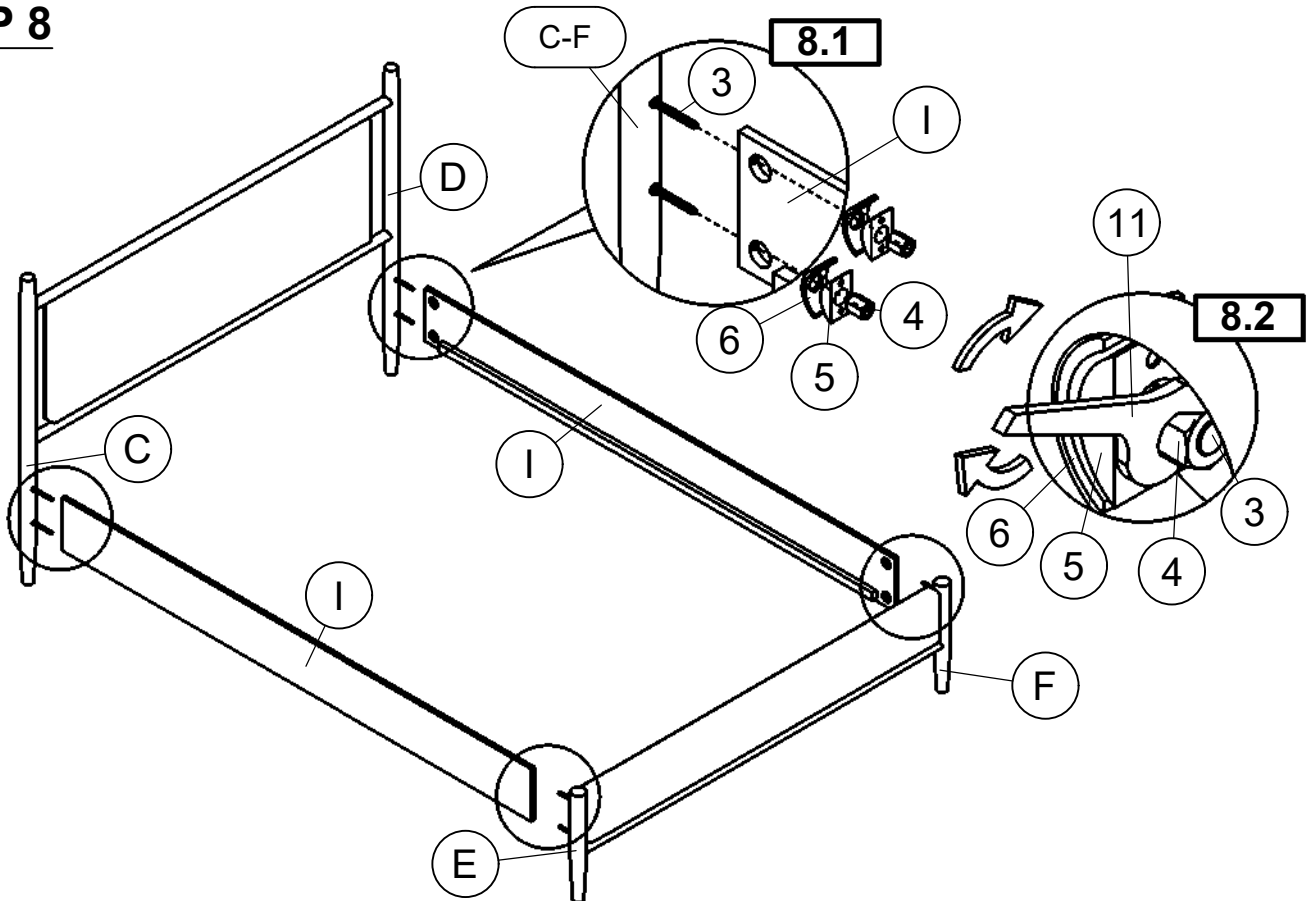

ITEM: 315914Q(B1&B2)

ASSEMBLY INSTRUCTIONS



STEP 9

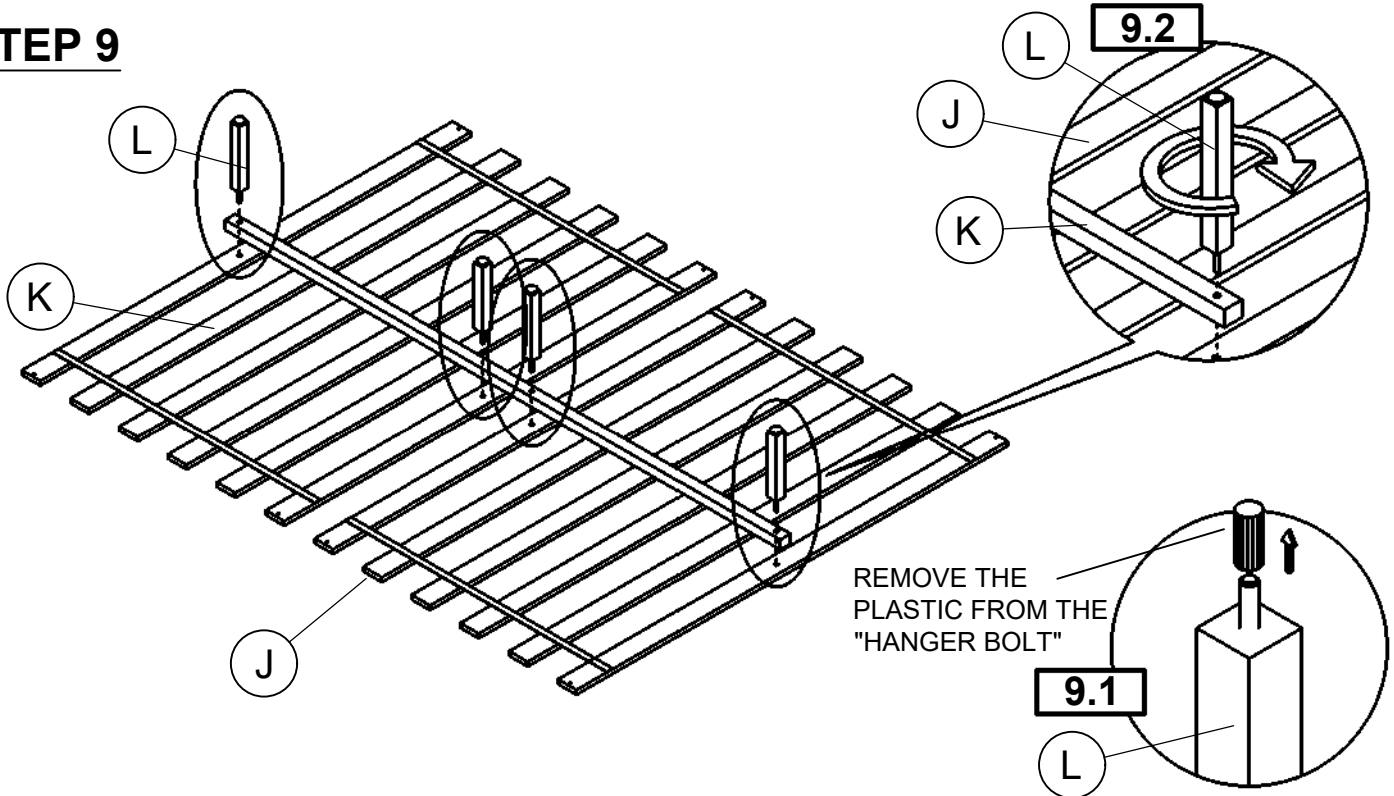

STEP 10

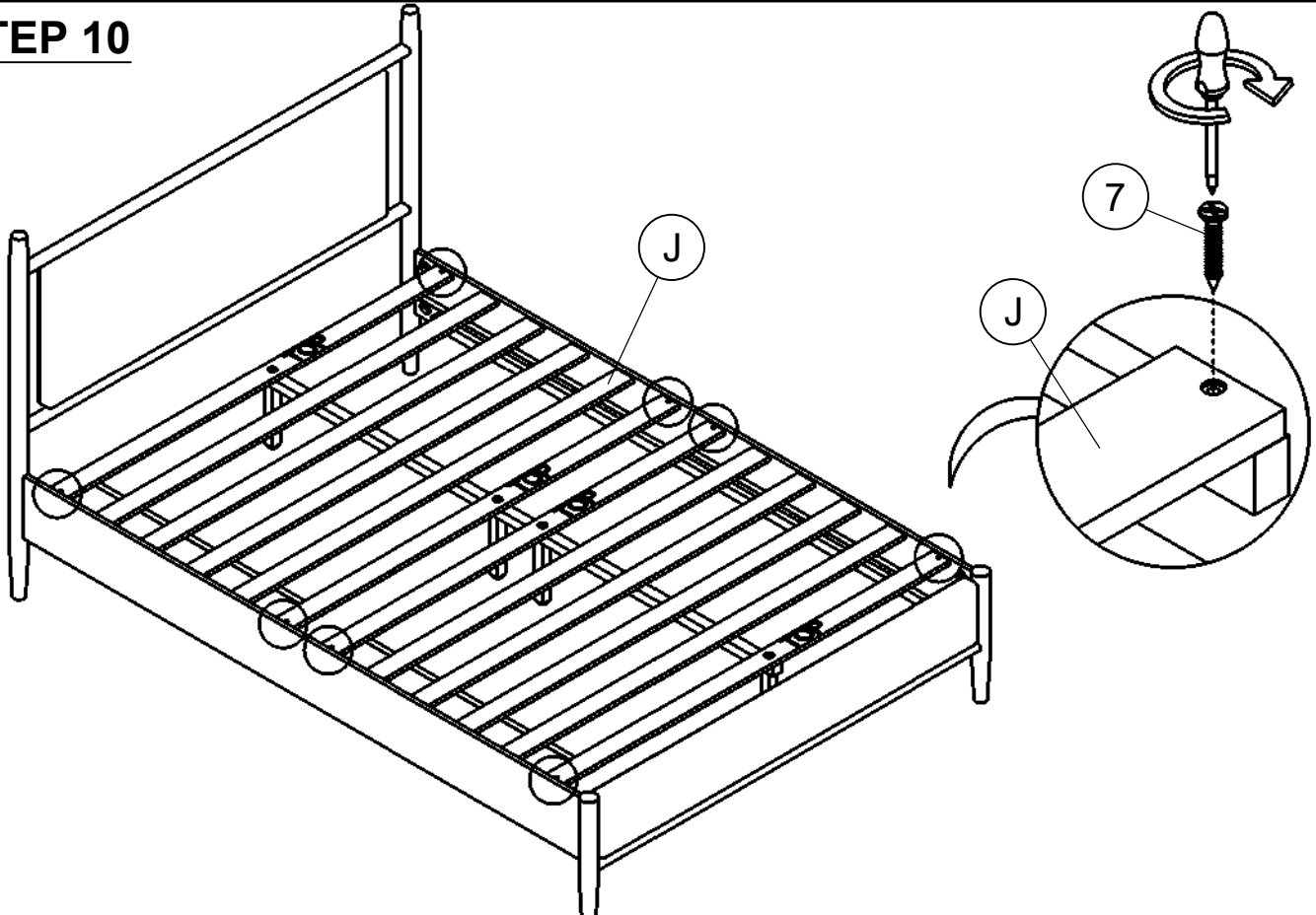

ITEM: **315914Q(B1&B2)**

ASSEMBLY INSTRUCTIONS



STEP 11

COMPLETE

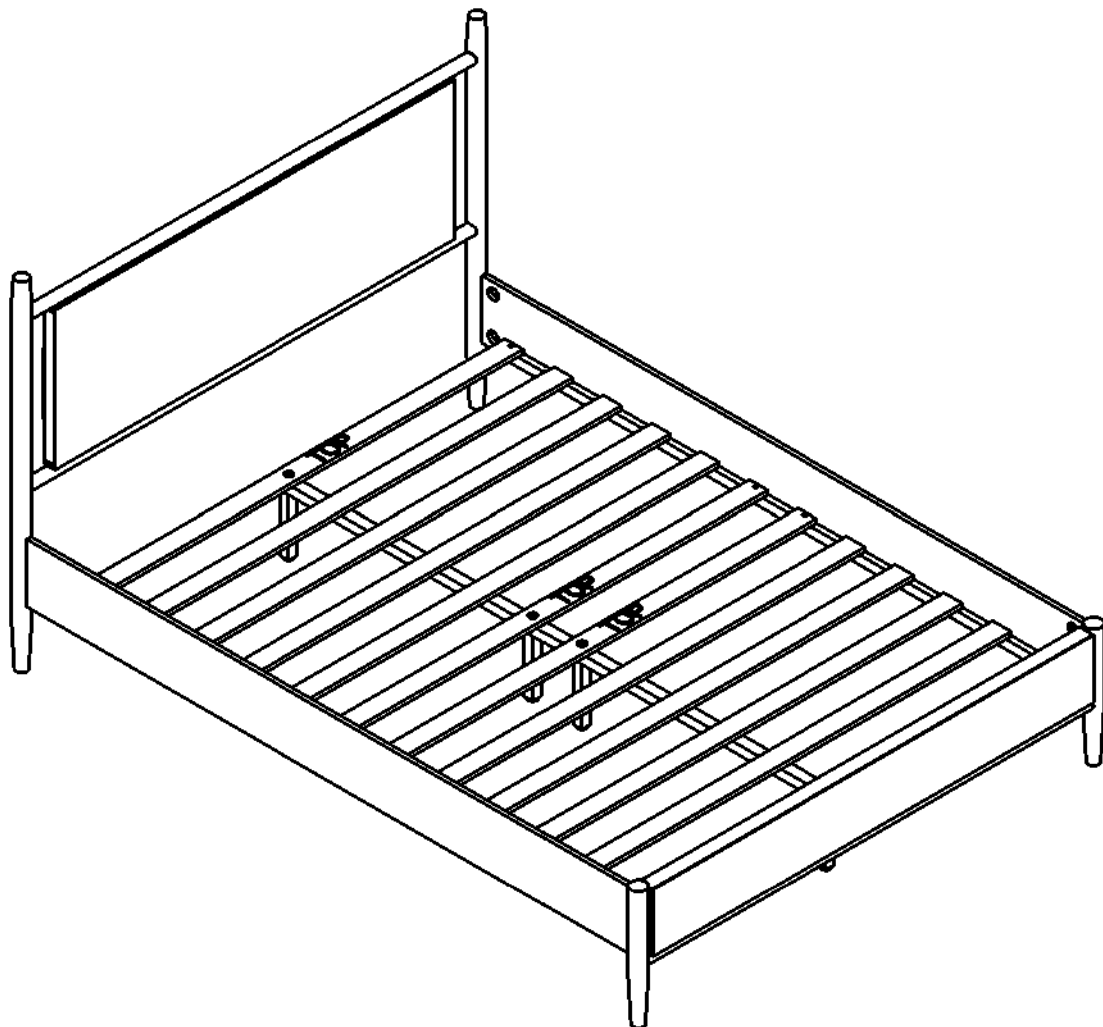

ITEM: **315914Q(B1&B2)**



Inner size: 60.75"W X 81.00"D

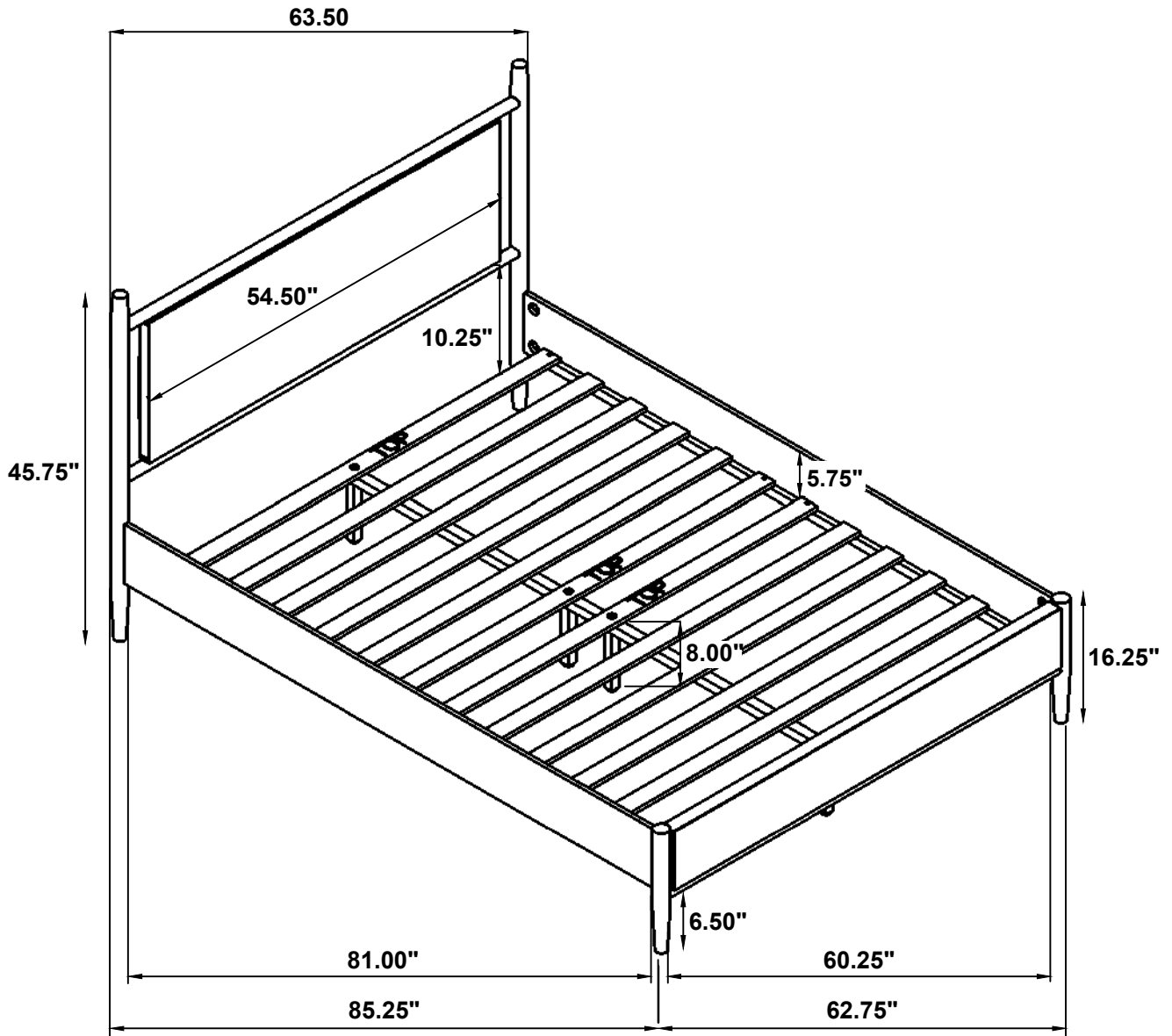

Note : Dimension tolerance $\pm 5\%$