

ASSEMBLY INSTRUCTIONS
COASTER FINE FURNITURE



Fine Furniture for every stage of life

316011F(B1&B2)
Full Bed

ITEM: 316011F(B1&B2)



ASSEMBLY INSTRUCTIONS

ASSEMBLY TIPS:

1. Remove hardware from box and sort by size.
2. Please check to see that all hardware and parts are present prior to start of assembly.
3. Please follow attached instructions in the same sequence as numbered to assure fast & easy assembly.



WARNING!

1. Don't attempt to repair or modify parts that are broken or defective. Please contact the store immediately.
2. This product is for home use only and not intended for commercial establishments.



ASSEMBLY TIME

30 MINUTES

PARTS IDENTIFICATION

B1 (BOX 1)

A	HEADBOARD PANEL		1PC	H	BED RAIL DRAWER SUPPORT		4PCS
B	LEFT HEADBOARD LEG (WITH "L" LABEL)		1PC	I	FOOTBOARD DRAWER BACK PANEL (WITH "D" LABEL)		2PCS
C	RIGHT HEADBOARD LEG (WITH "R" LABEL)		1PC	J	FOOTBOARD DRAWER BOTTOM PANEL		2PCS
D	BED RAIL DRAWER BACK PANEL (WITH "D" LABEL)		2PCS	K	FOOTBOARD DRAWER SUPPORT		4PCS
E	DRAWER LEFT SIDE PANEL (WITH "E" LABEL)		4PCS	L	CASTER WITH SCREW		16SETS
F	DRAWER RIGHT SIDE PANEL (WITH "F" LABEL)		4PCS	M	ROLL SLAT (23PCS)		1SET
G	BED RAIL DRAWER BOTTOM PANEL		2PCS				

B2 (BOX 2)

N	SIDE DRAWER FRONT PANEL		2PCS	R	BED RAIL		2PCS
O	FRONT DRAWER FRONT PANEL		2PCS	S	BED RAIL SUPPORT LEG		4PCS
P	FOOTBOARD FRAME		1PC	T	CENTER RAIL		1PC
Q	FOOTBOARD LEG		2PCS	U	CENTER RAIL SUPPORT WITH LEVELER		3PCS

NOTE:

Phillips head screw driver is required in the assembly process; however, manufacturer does not provided this item.

ITEM: 316011F(B1&B2)



ASSEMBLY INSTRUCTIONS

ASSEMBLY TIPS:

1. Remove hardware from box and sort by size.
2. Please check to see that all hardware and parts are present prior to start of assembly.
3. Please follow attached instructions in the same sequence as numbered to assure fast & easy assembly.







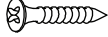

WARNING!

1. Don't attempt to repair or modify parts that are broken or defective. Please contact the store immediately.
2. This product is for home use only and not intended for commercial establishments.

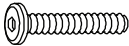
HARDWARE IDENTIFICATION

Z-B2 (BOX 2) - HARDWARE PACK IS LOCATED IN 316011F (B2)

1	SHORT BOLT (M8 x 20MM - RBW)		8PCS	6	FLAT HEAD SCREW (M4 x 32MM - RBW)		38PCS
2	MEDIUM BOLT (M6 x 35MM - RBW)		16PCS	7	WOOD DOWEL (M8 x 30MM)		66PCS
3	LONG BOLT (M6 x 50MM - RBW)		8PCS	8	SMALL ALLEN WRENCH (M4 x 65MM - BLK)		1PC
4	LOCK WASHER (15/64" X 13 Ø - RBW)		14PCS	9	BIG ALLEN WRENCH (M5 x 65MM - BLK)		1PC
5	FLAT WASHER (15/64" X 19 Ø - RBW)		14PCS				

NOTE:

Phillips head screw driver is required in the assembly process; however, manufacturer does not provided this item.

ITEM: 316011F(B1&B2)

ASSEMBLY INSTRUCTIONS



STEP 1

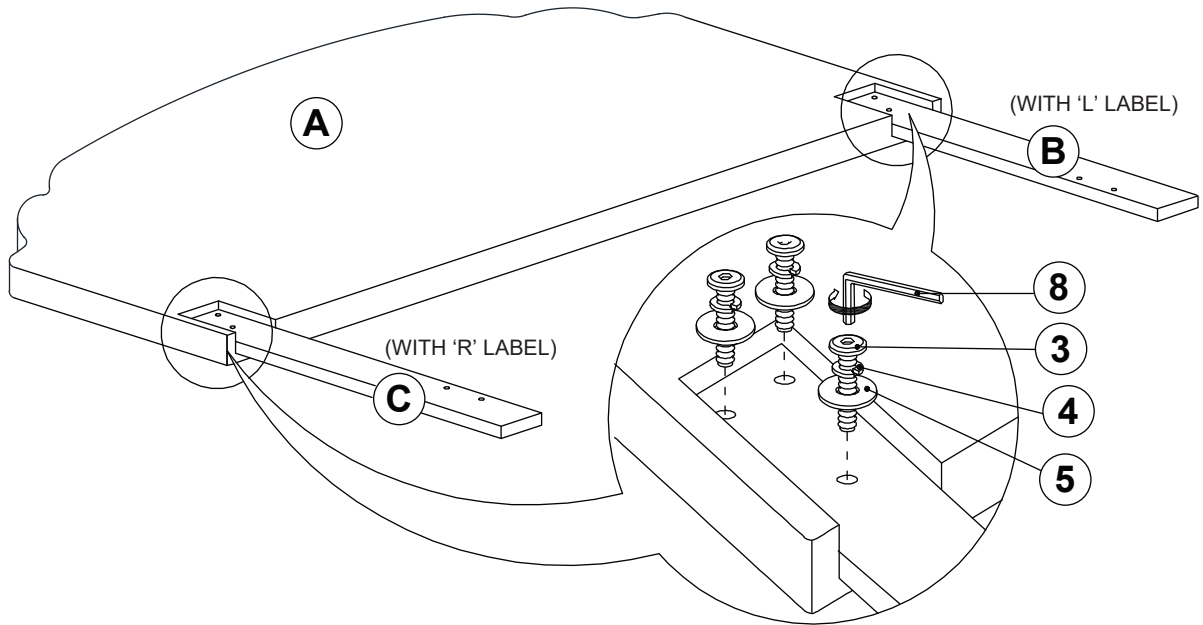

***BACK VIEW**

STEP 2

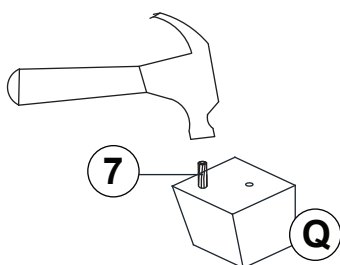
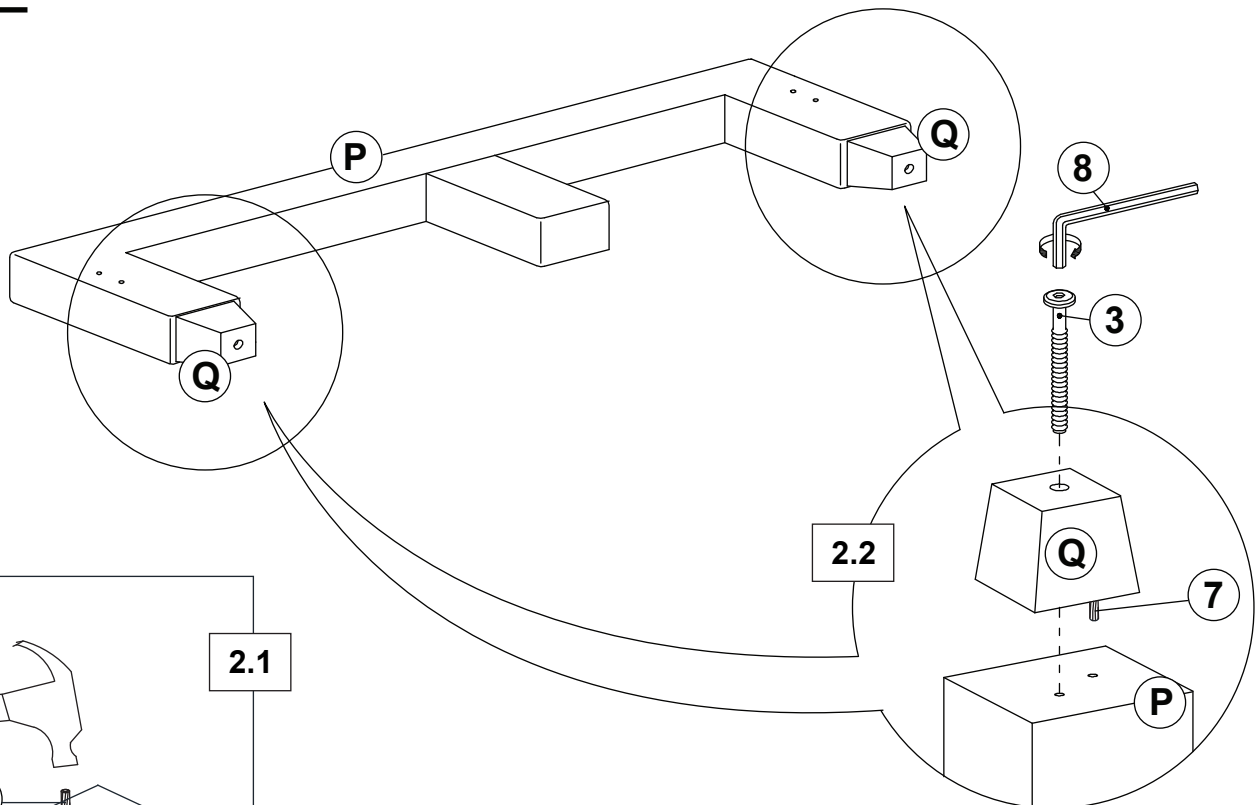

2.1

2.2

ITEM: 316011F(B1&B2)

ASSEMBLY INSTRUCTIONS



STEP 3

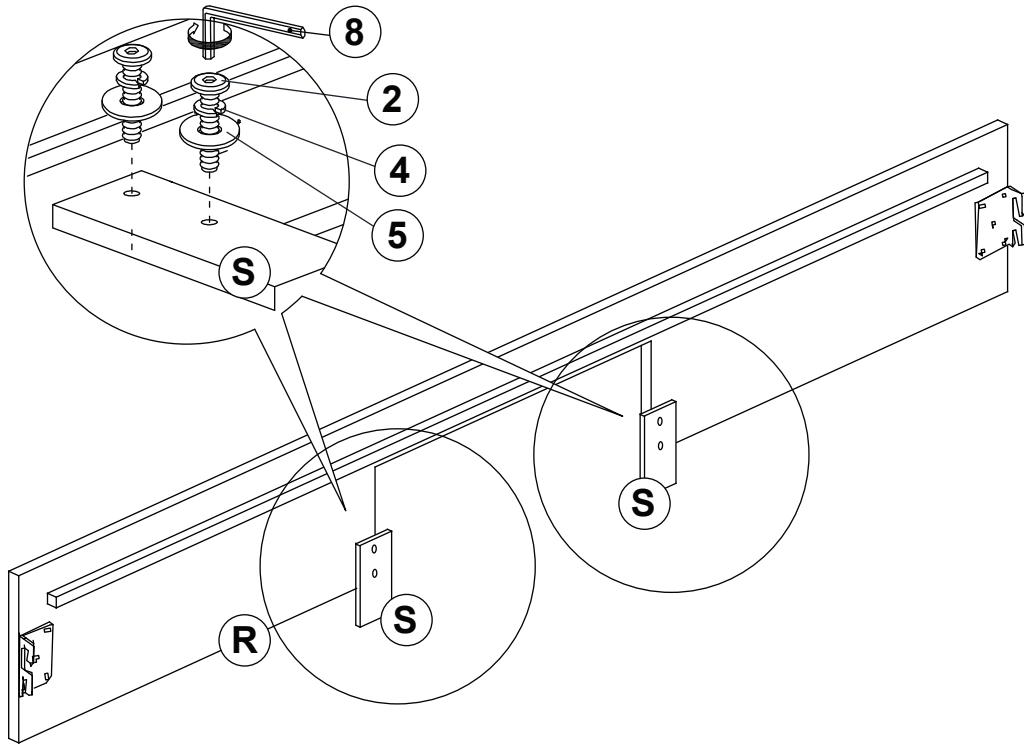

STEP 4

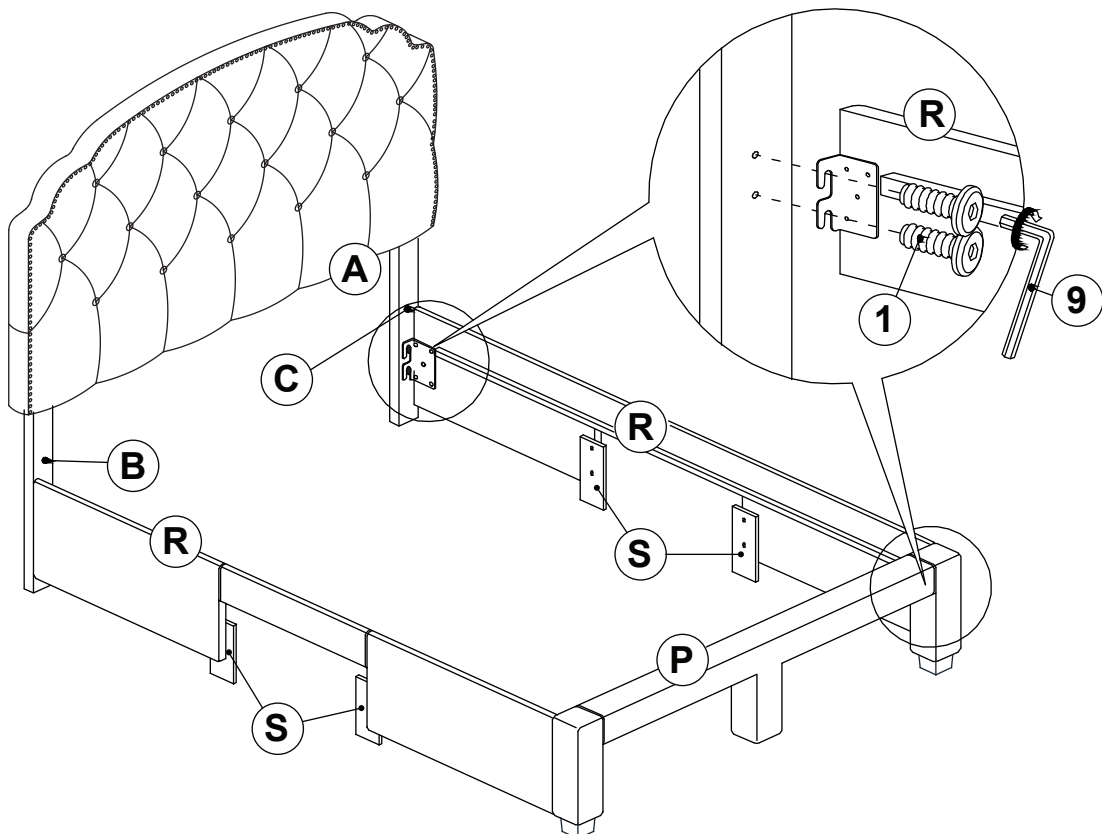

ITEM: **316011F(B1&B2)**

ASSEMBLY INSTRUCTIONS



STEP 5

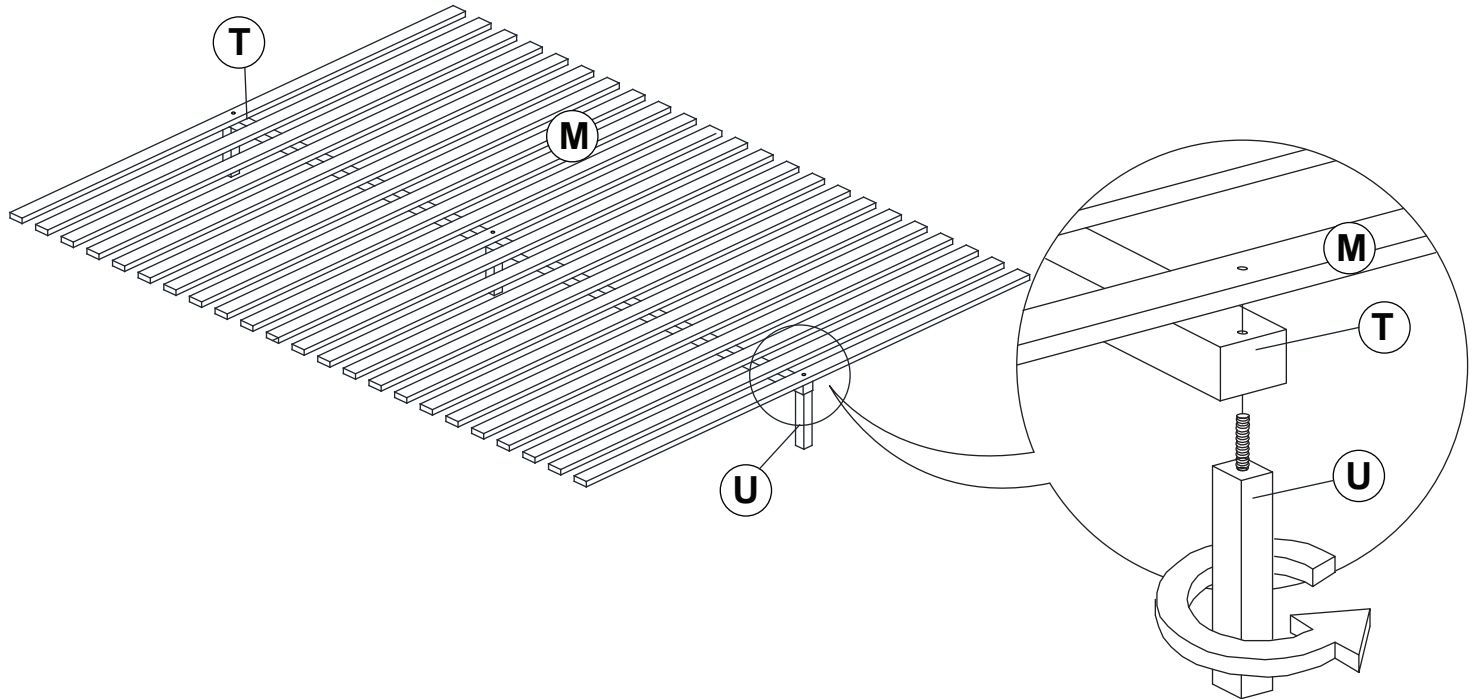

STEP 6

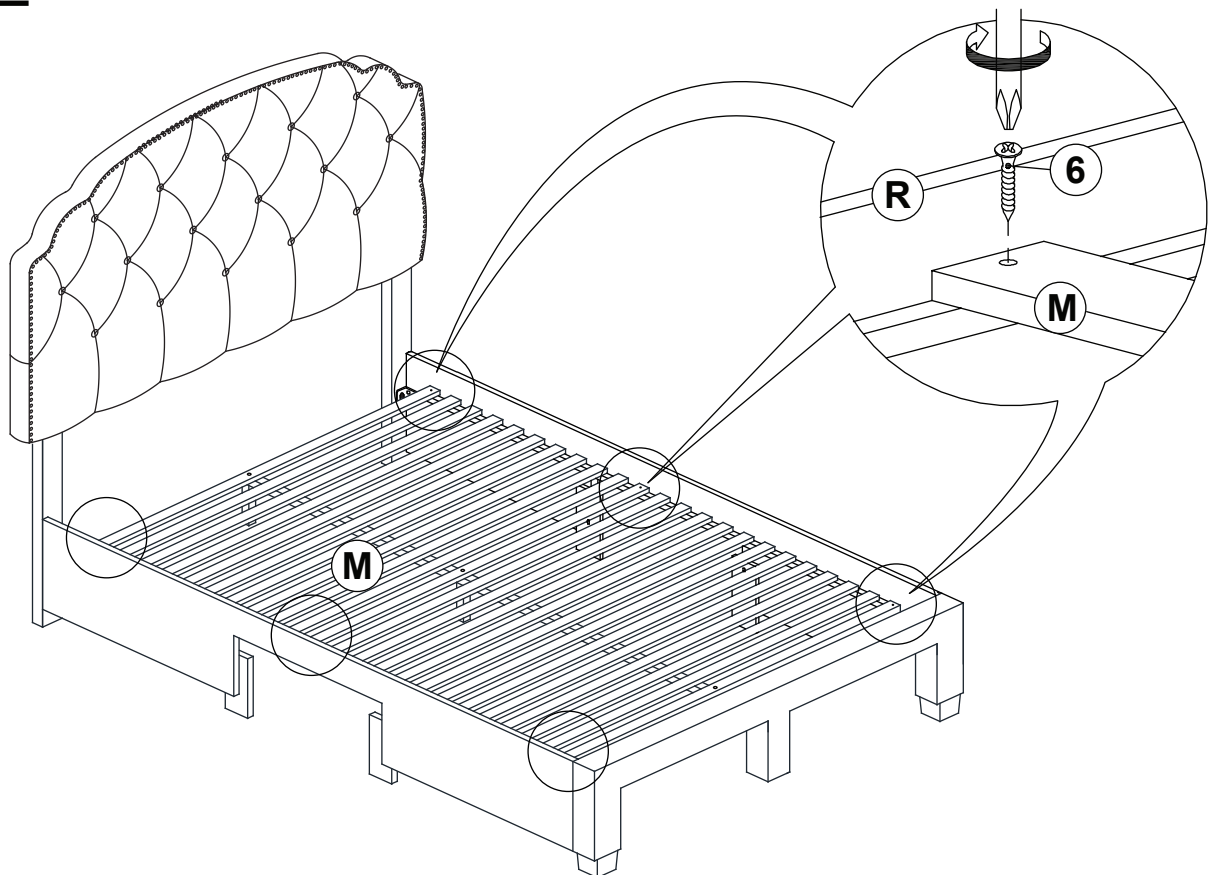

ITEM: 316011F(B1&B2)

ASSEMBLY INSTRUCTIONS



STEP 7

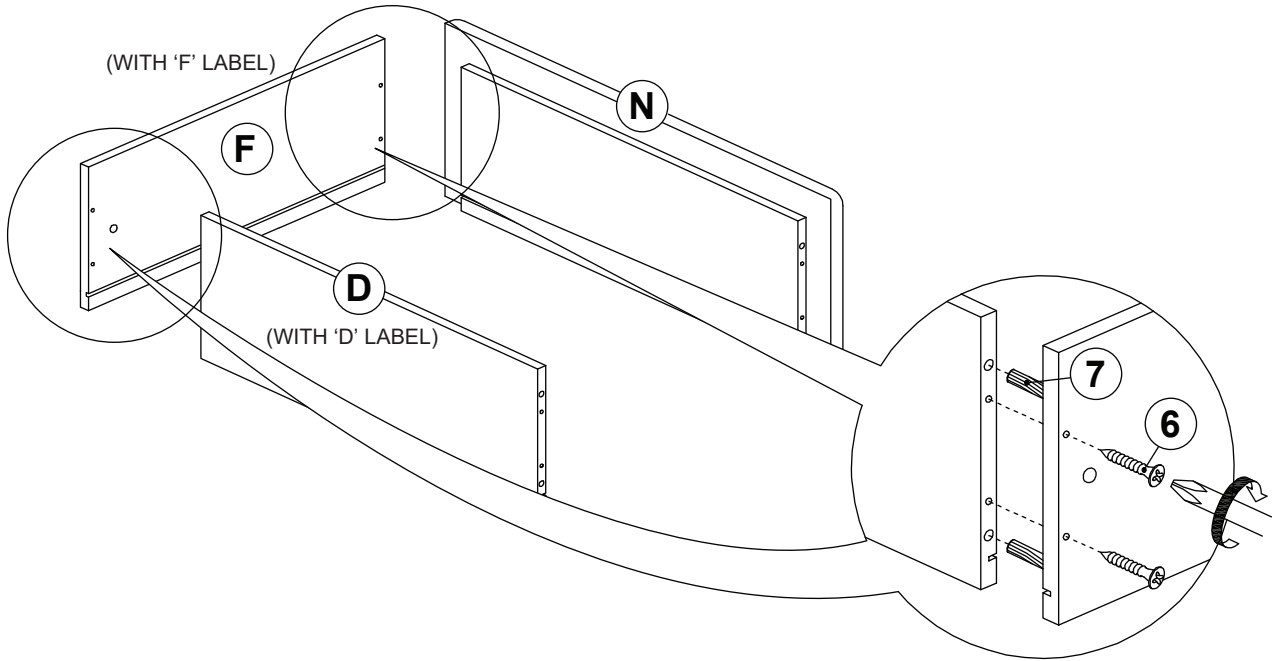

STEP 8

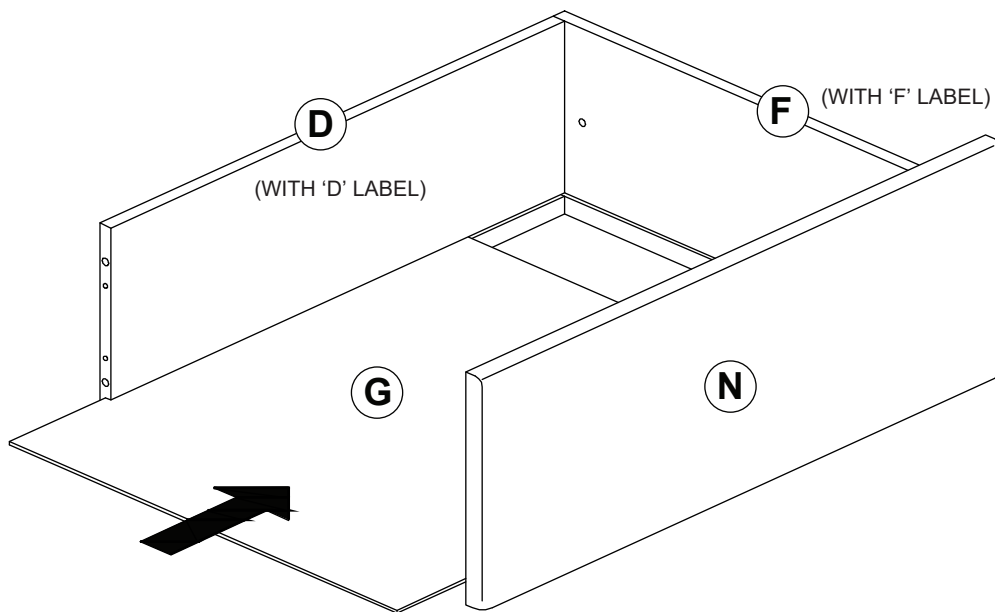

ITEM: **316011F(B1&B2)**

ASSEMBLY INSTRUCTIONS



STEP 9

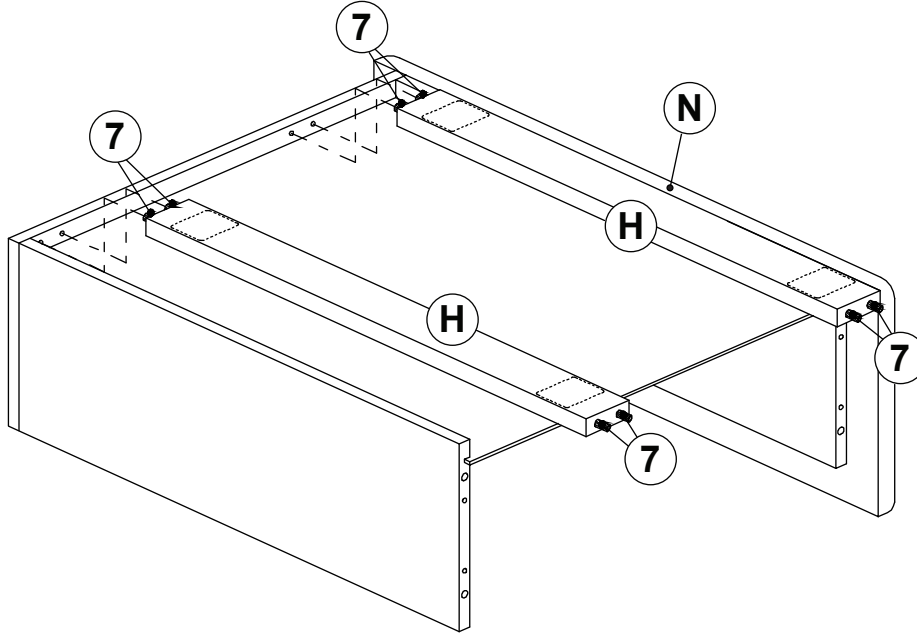

STEP 10

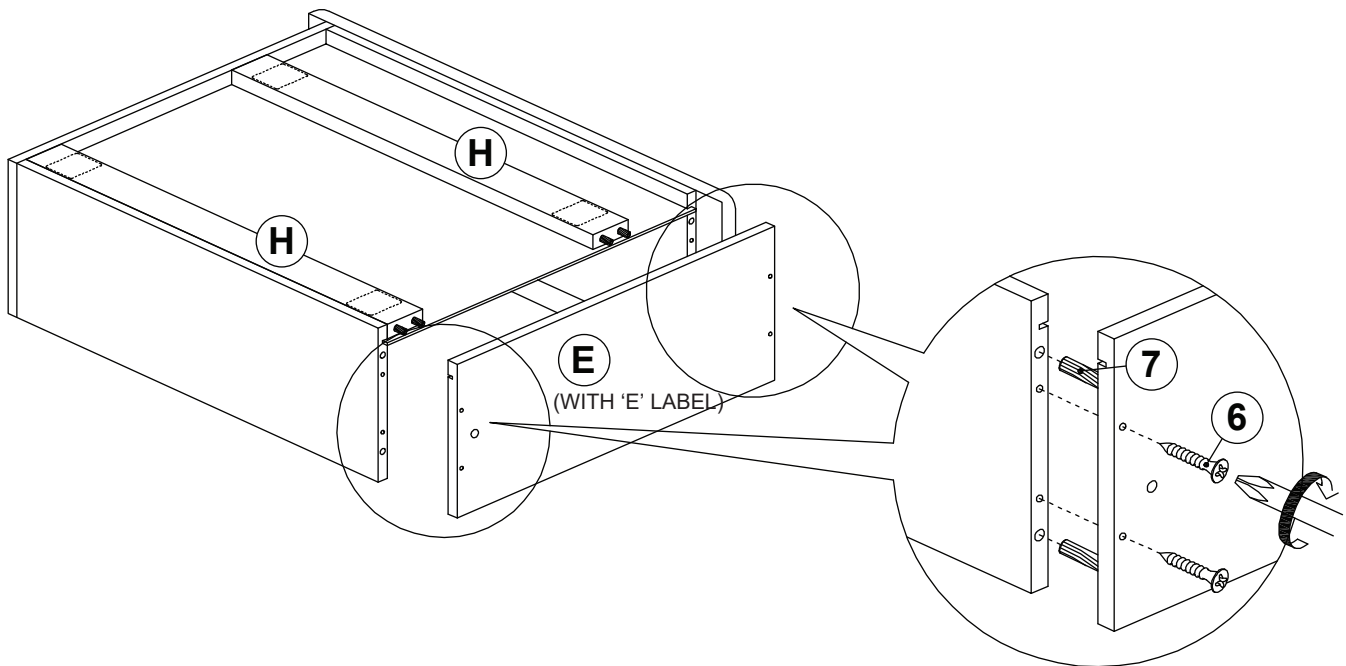

ITEM: **316011F(B1&B2)**

ASSEMBLY INSTRUCTIONS



STEP 11

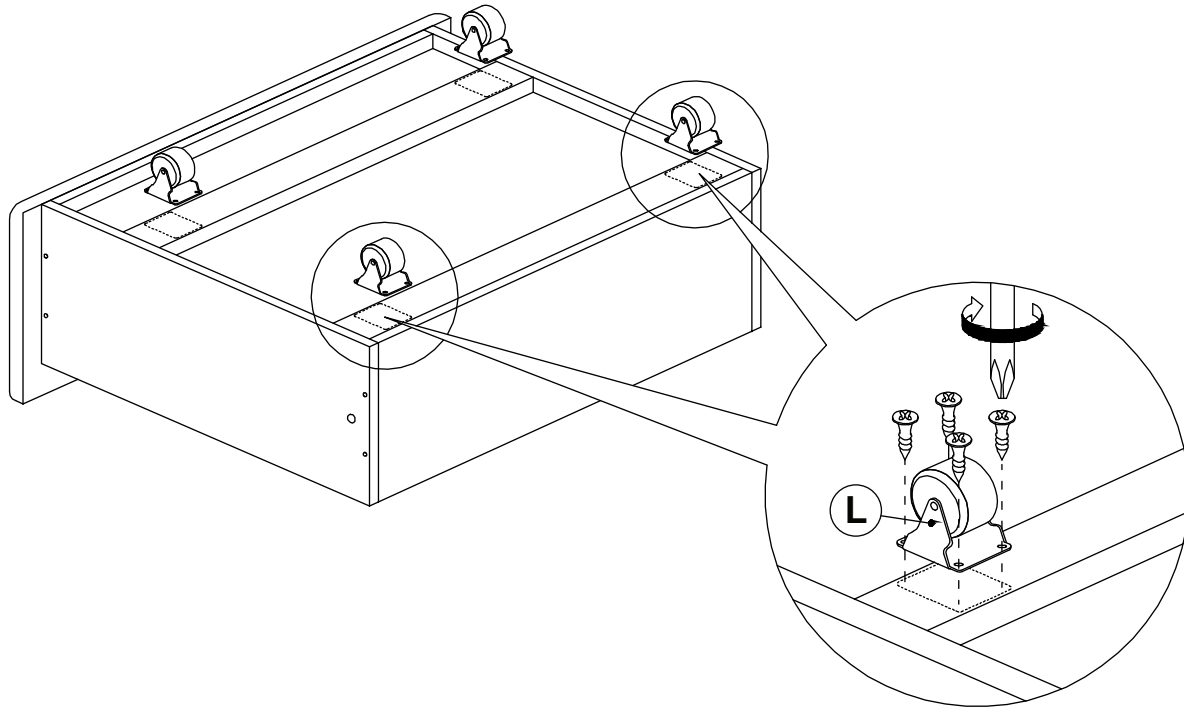

STEP 12

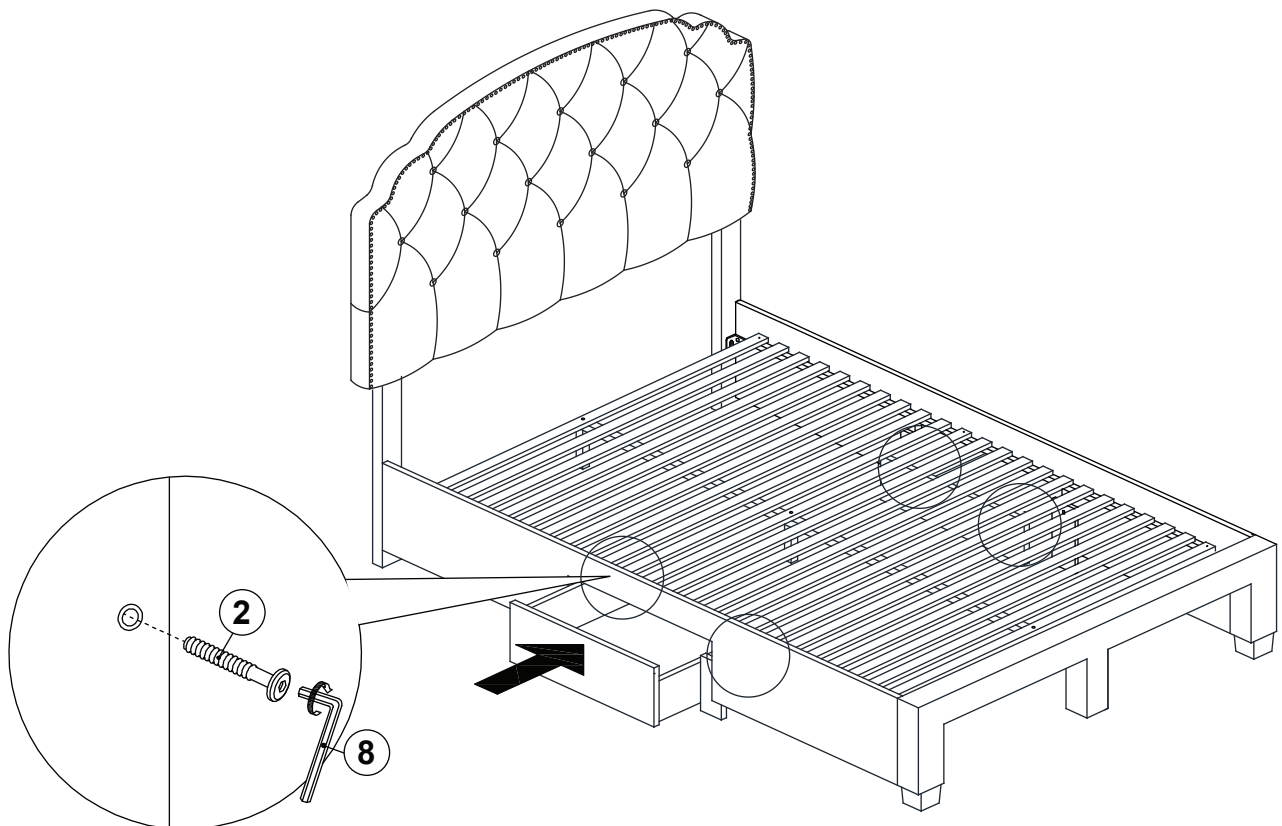

ITEM: 316011F(B1&B2)

ASSEMBLY INSTRUCTIONS



STEP 13

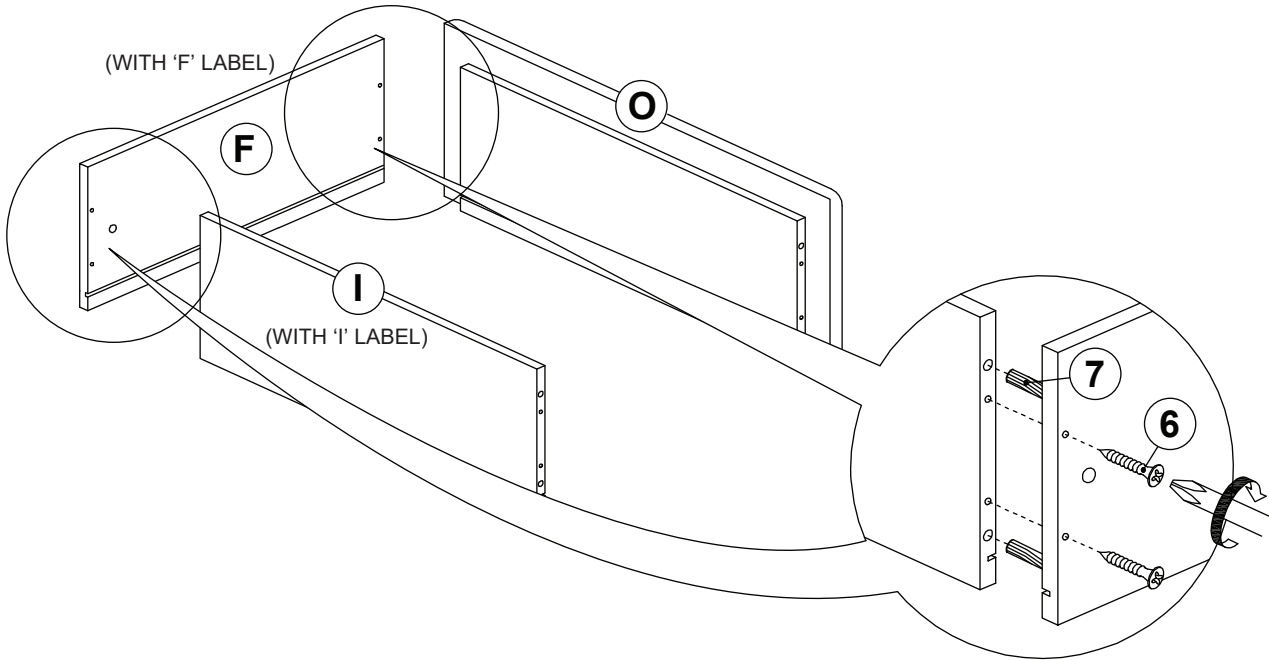

STEP 14

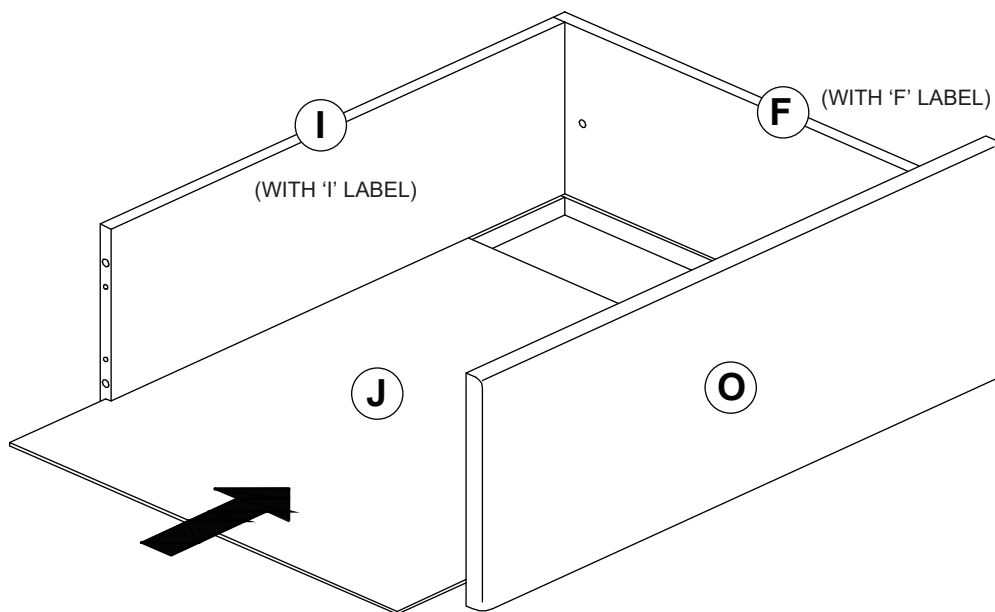

ITEM: **316011F(B1&B2)**

ASSEMBLY INSTRUCTIONS



STEP 15

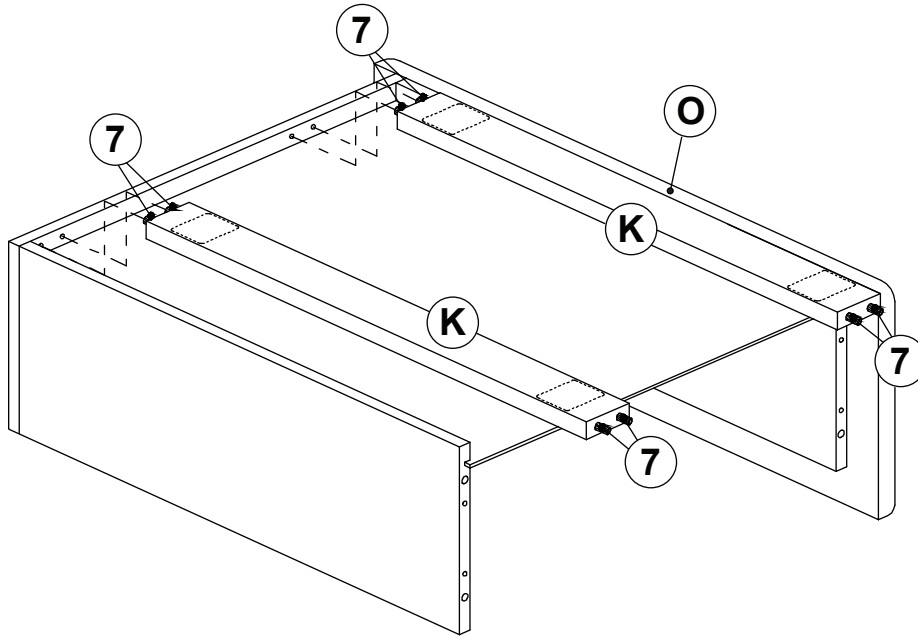

STEP 16

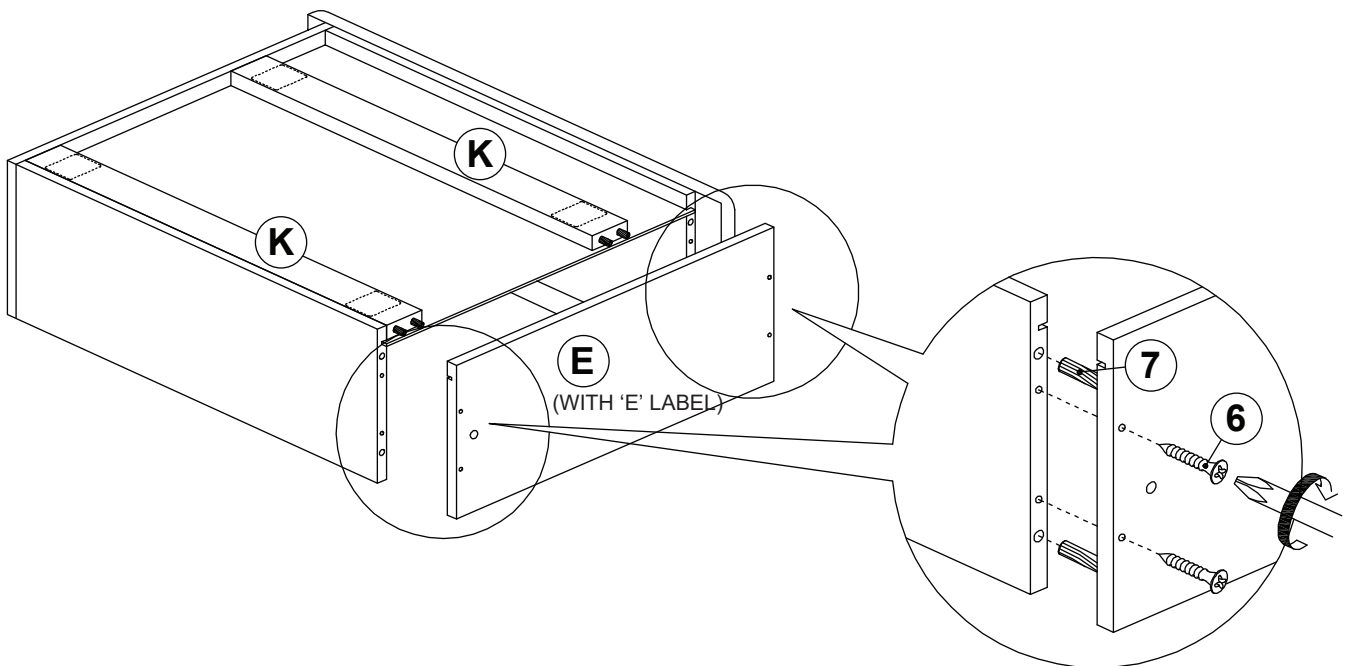

ITEM: **316011F(B1&B2)**

ASSEMBLY INSTRUCTIONS



STEP 17

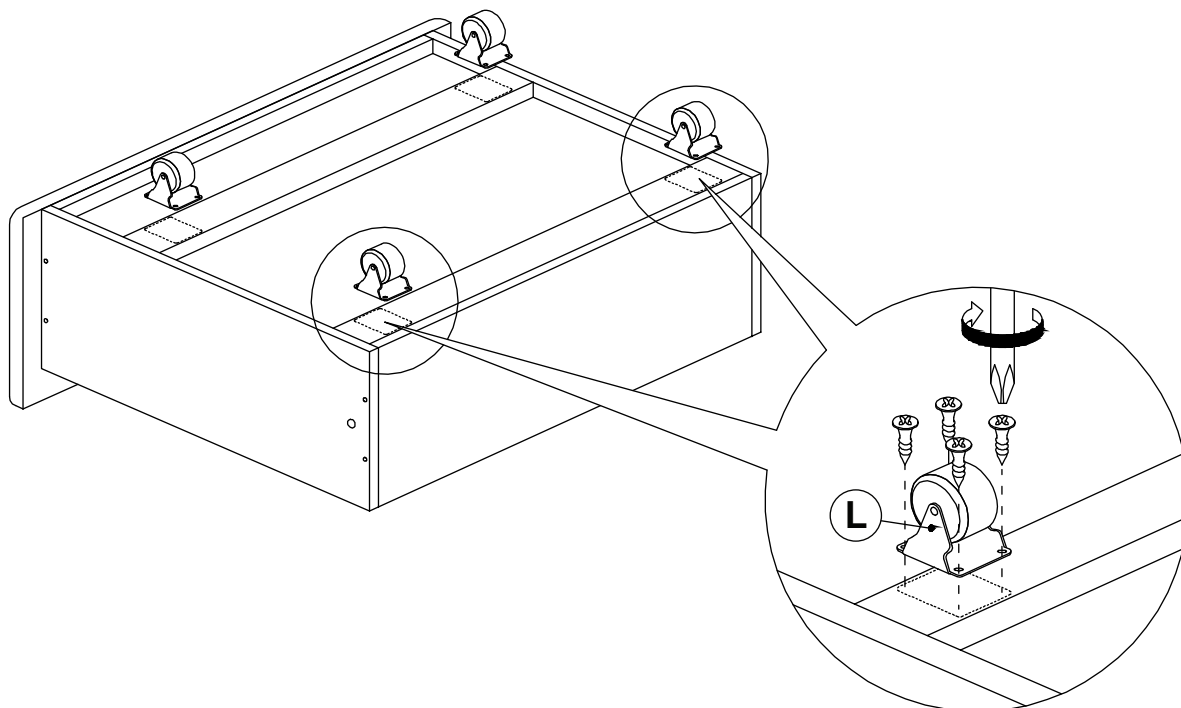

STEP 18

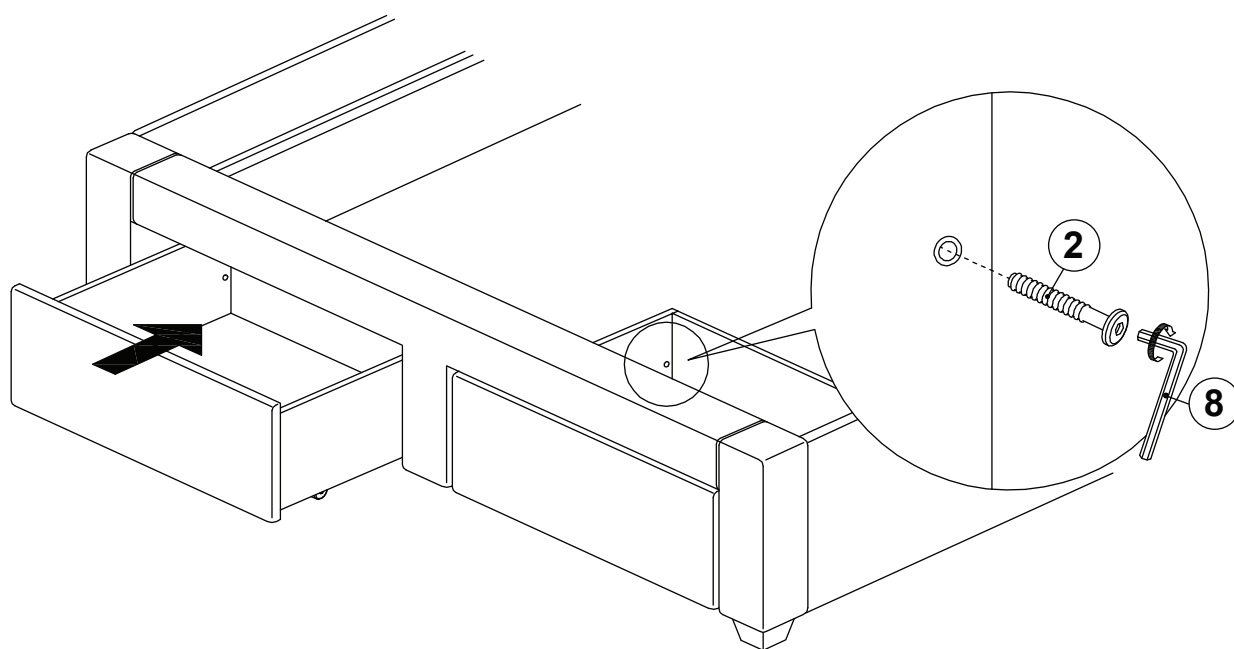

ITEM: **316011F(B1&B2)**

ASSEMBLY INSTRUCTIONS



STEP 19

COMPLETE

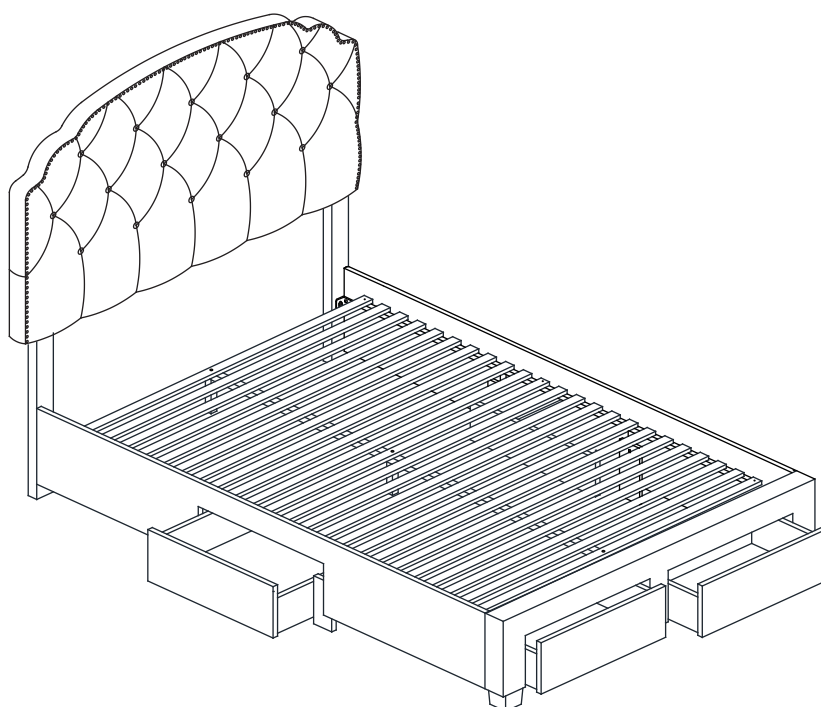

ITEM: 316011F(B1&B2)



Inner Size of : 54.50"W x 76.00"D

Inner Size of Front Drawer : 19.50"W x 17.75"D x 5.75"H x 0.50"T

Inner Size of Side Drawer : 22.50"W x 17.75"D x 5.75"H x 0.50"T

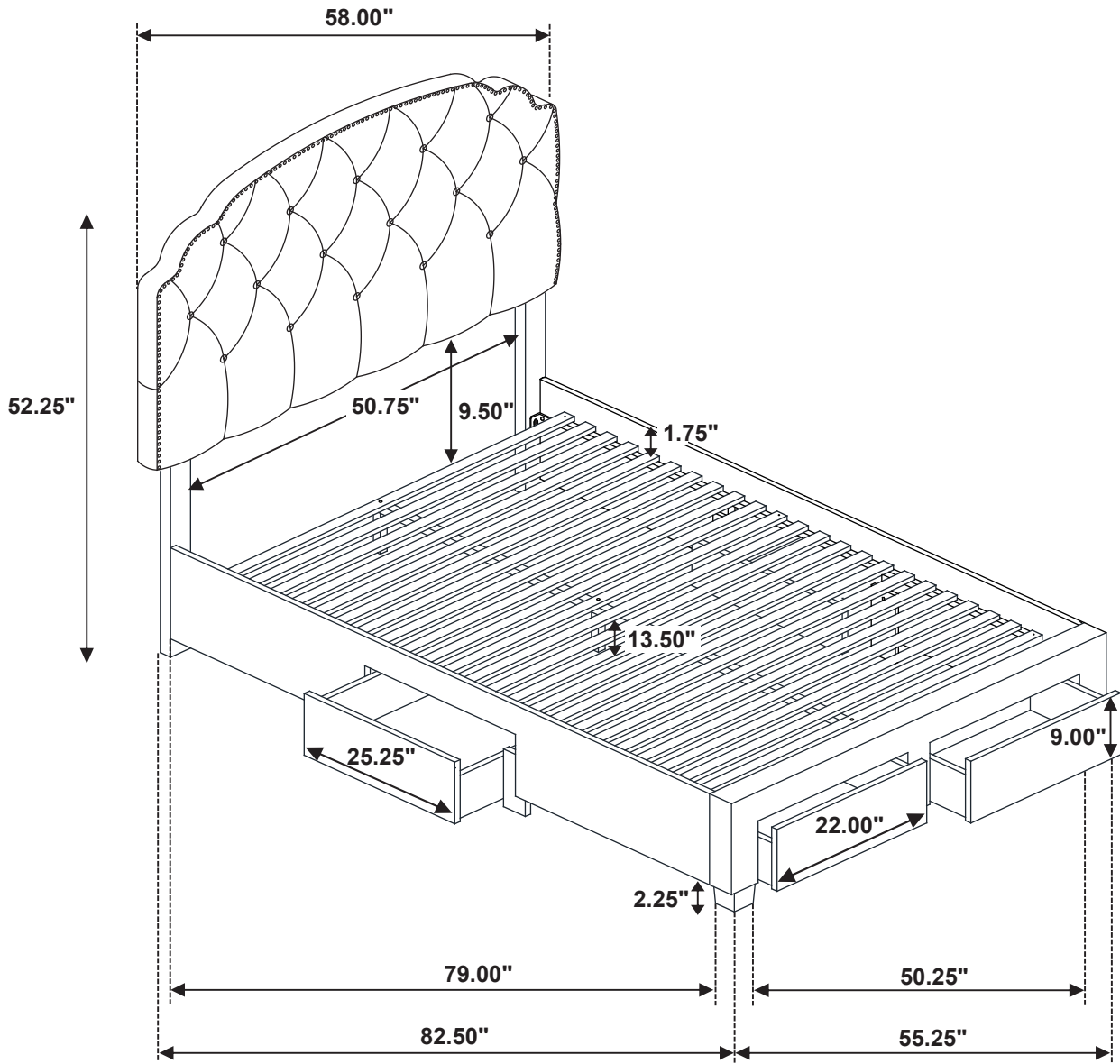

Note : Dimension tolerance $\pm 5\%$