

ASSEMBLY INSTRUCTIONS
COASTER FINE FURNITURE

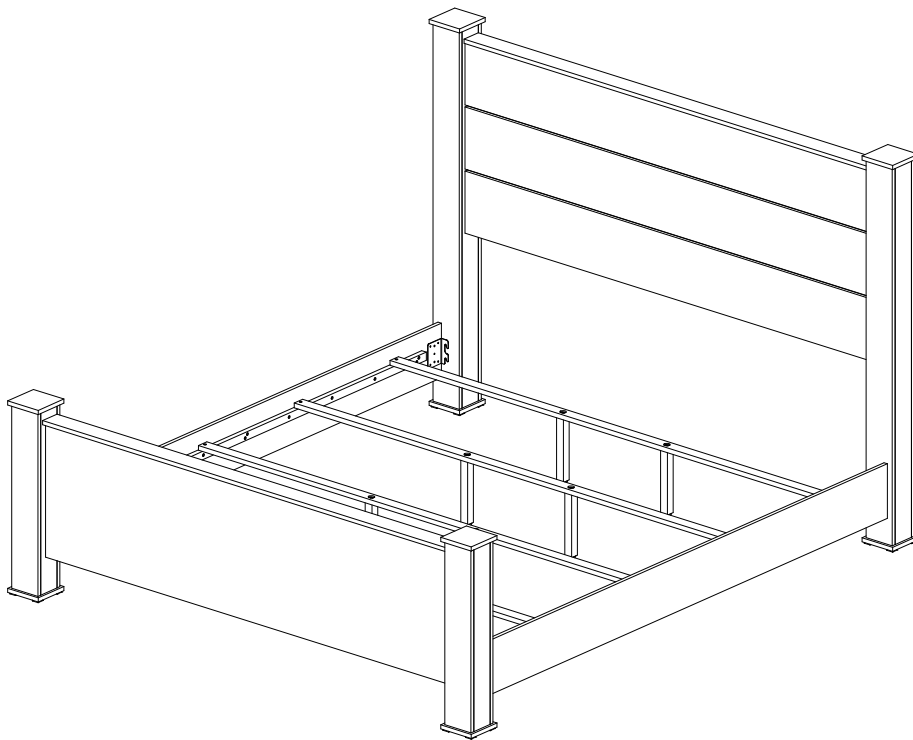

Fine Furniture for every stage of life

225101KW (B1&B2)
California King Bed

ITEM: 225101KW (B1&B2)



ASSEMBLY INSTRUCTIONS

ASSEMBLY TIPS:

1. Remove hardware from box and sort by size.
2. Please check to see that all hardware and parts are present prior to start of assembly.
3. Please follow attached instructions in the same sequence as numbered to assure fast & easy assembly.



WARNING!

1. Don't attempt to repair or modify parts that are broken or defective. Please contact the store immediately.
2. This product is for home use only and not intended for commercial establishments.

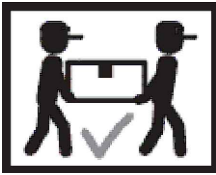

ASSEMBLY TIME

30 MINUTES

PART IDENTIFICATION

B1 (BOX 1)

A HEADBOARD
PANEL

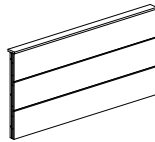

1PC

E LEFT FOOTBOARD
LEG
(WITH "L" LABEL)



1PC

B LEFT HEADBOARD
LEG
(WITH "L" LABEL)

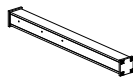

1PC

F RIGHT FOOTBOARD
LEG
(WITH "R" LABEL)



1PC

C RIGHT HEADBOARD
LEG
(WITH "R" LABEL)

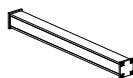

1PC

H BED SLAT SUPPORT
WITH LEVELER



8PCS

D FOOTBOARD
PANEL

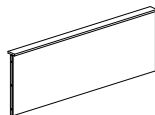

1PC

B2 (BOX 2)

I BED RAIL

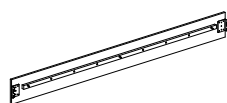

2PCS

G BED SLAT



4PCS

ITEM: 225101KW (B1&B2)

ASSEMBLY INSTRUCTIONS



ASSEMBLY TIPS:

1. Remove hardware from box and sort by size.
2. Please check to see that all hardware and parts are present prior to start of assembly.
3. Please follow attached instructions in the same sequence as numbered to assure fast & easy assembly.









WARNING!

1. Don't attempt to repair or modify parts that are broken or defective. Please contact the store immediately.
2. This product is for home use only and not intended for commercial establishments.

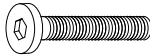
HARDWARE IDENTIFICATION

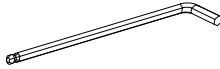
Z-B1 (BOX 1) - HARDWARE IS LOCATED IN 225101KW (B1)

1	SHORT BOLT (M8 x 16MM - RBW)		8PCS
2	BIG ALLEN WRENCH (M5 x 68MM - BLK)		1PC
3	LONG BOLT (M6 x 40MM - RBW)		12PCS
4	LOCK WASHER (1/4" x 13Ø - RBW)		12PCS
5	FLAT WASHER (1/4" x 19Ø - RBW)		12PCS
6	SMALL ALLEN WRENCH (M4 x 110MM - BLK)		1PC
7	FLAT HEAD SCREW (M4 x 32MM - RBW)		8PCS

NOTE:

Phillips head screw driver is required in the assembly process; however, manufacturer does not provided this item.

ITEM: **225101KW (B1&B2)**
ASSEMBLY INSTRUCTIONS

STEP 1

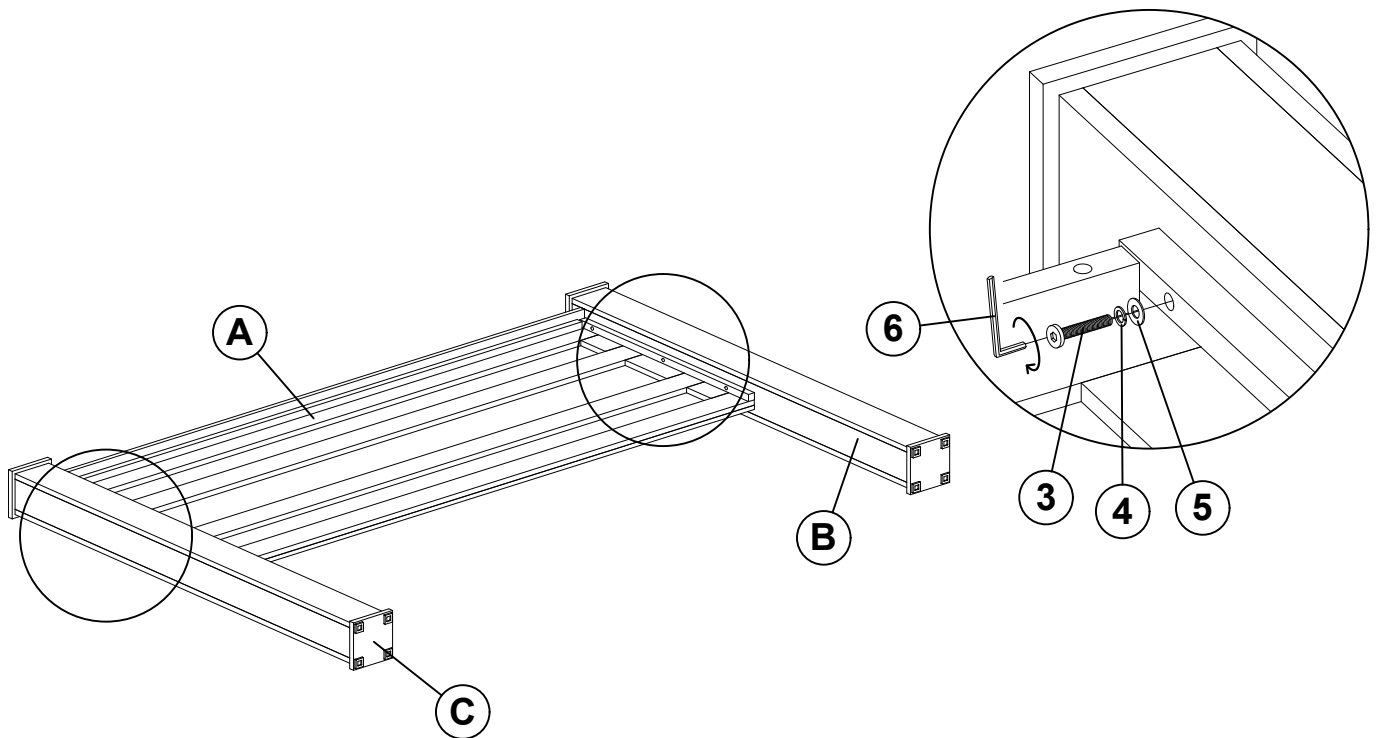

**** BACK VIEW**

STEP 2

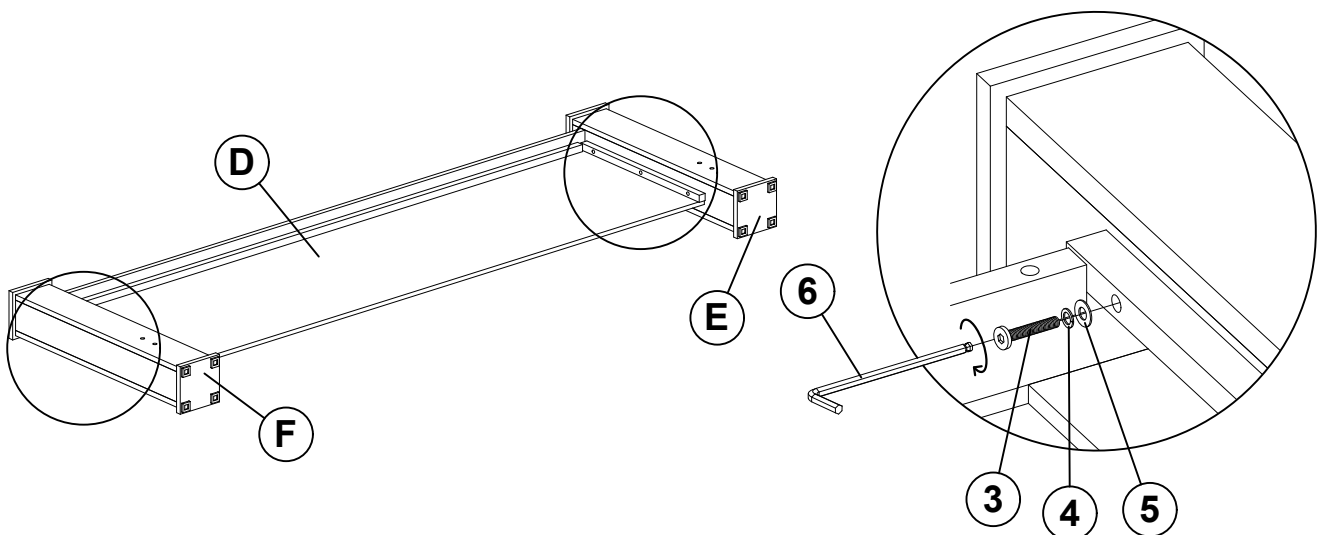

**** BACK VIEW**

ITEM: **225101KW (B1&B2)**
ASSEMBLY INSTRUCTIONS

STEP 3

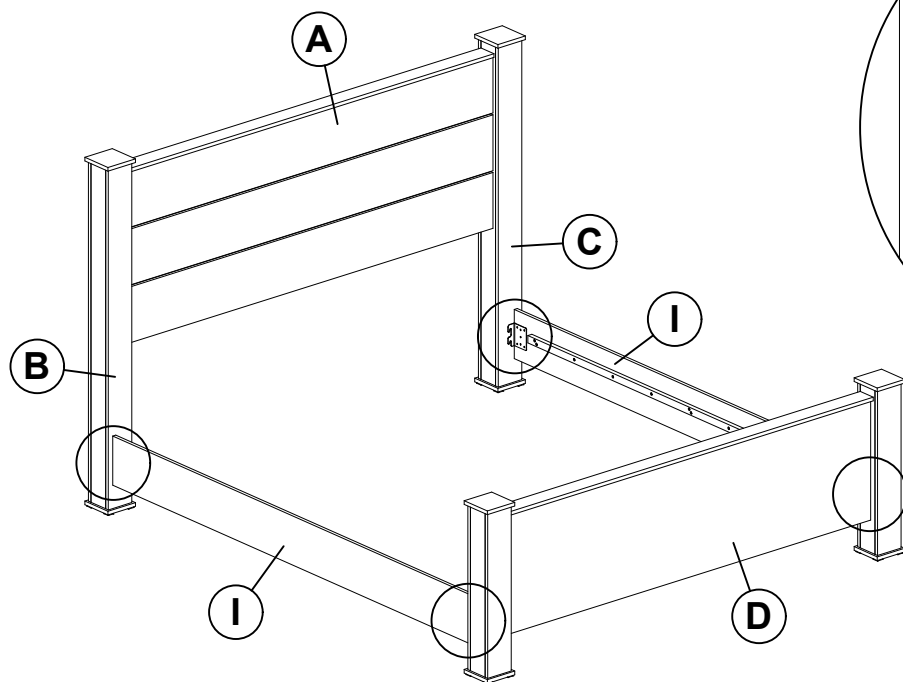

STEP 4

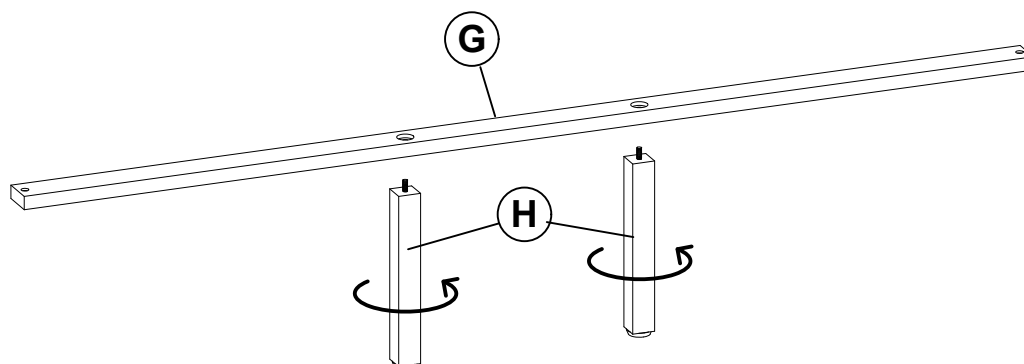

ITEM: **225101KW (B1&B2)**
ASSEMBLY INSTRUCTIONS



STEP 5

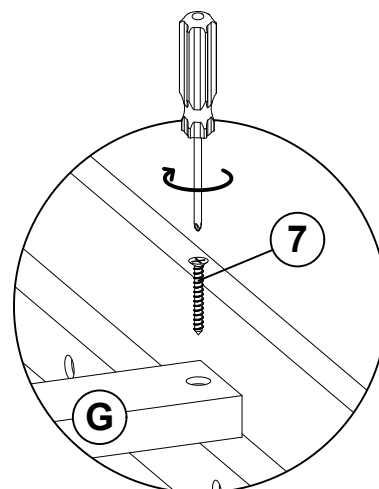
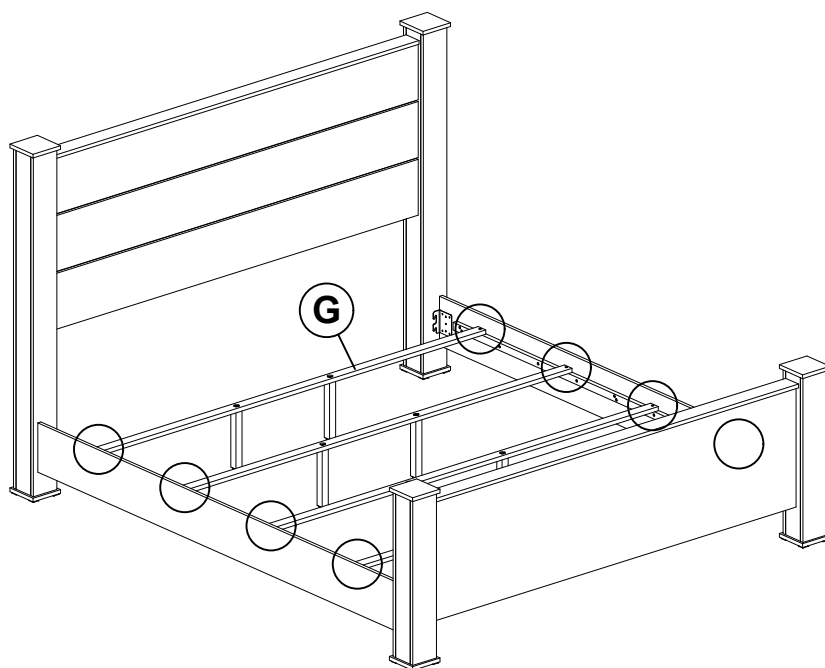

STEP 6
COMPLETE

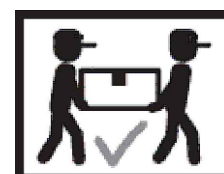
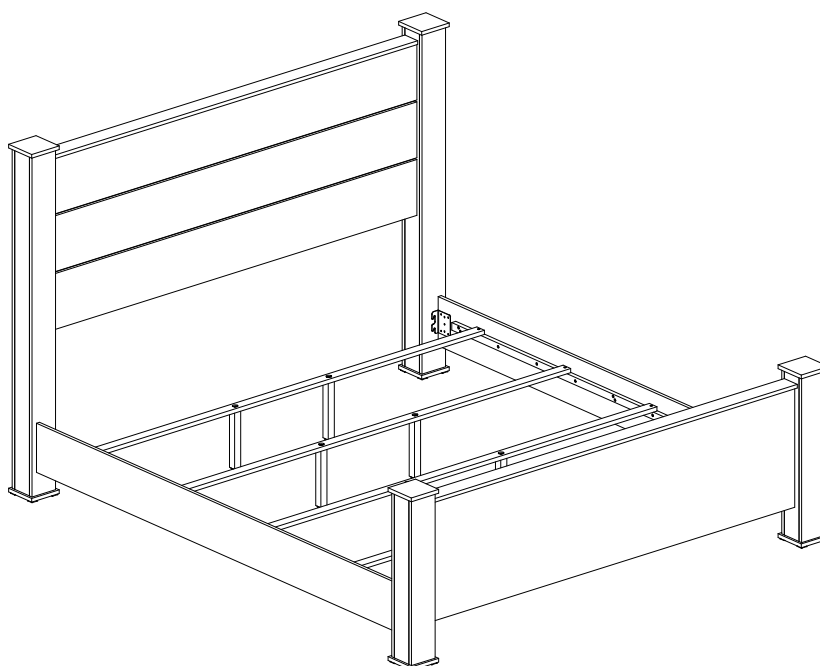

ITEM: **225101KW (B1&B2)**



Inner Size : 72.50"W X 85.00"D

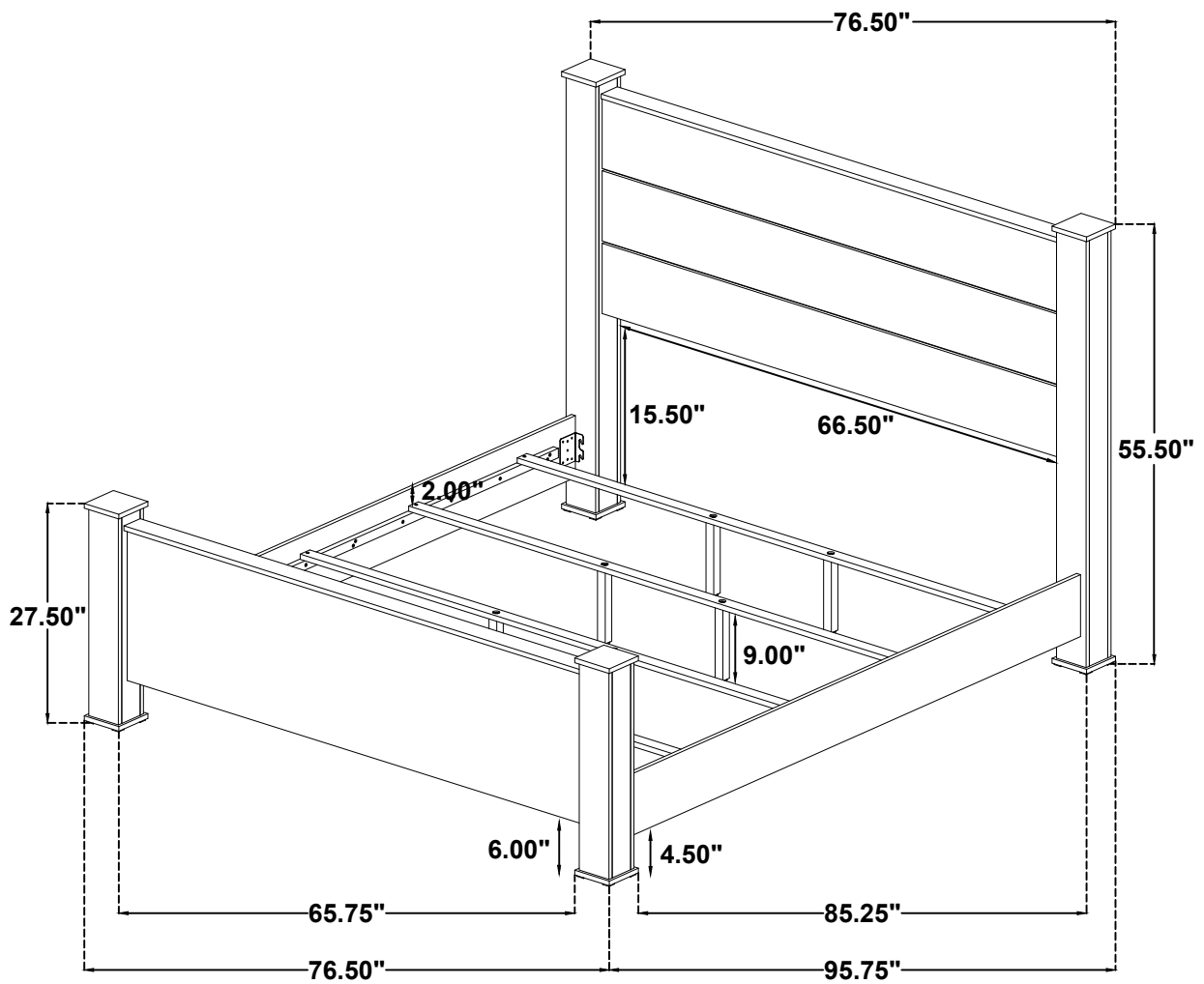

Note : Dimension tolerance $\pm 5\%$

ASSEMBLY INSTRUCTIONS
COASTER FINE FURNITURE



Fine Furniture for every stage of life

225102
Nightstand

ITEM: 225102

ASSEMBLY INSTRUCTIONS



ASSEMBLY TIPS:

1. Remove hardware from box and sort by size.
2. Please check to see that all hardware and parts are present prior to start of assembly.
3. Please follow attached instructions in the same sequence as numbered to assure fast & easy assembly.



WARNING!

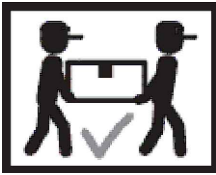

1. Don't attempt to repair or modify parts that are broken or defective. Please contact the store immediately.
2. This product is for home use only and not intended for commercial establishments.





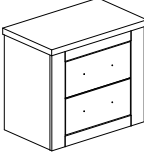

ASSEMBLY TIME

10 MINUTES

PART IDENTIFICATION

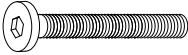
A	NIGHTSTAND		1PC
B	LEG (WITH "B" LABEL)		2PCS
C	LEG (WITH "C" LABEL)		2PCS

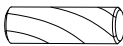
HARDWARE IDENTIFICATION

1	BOLT (M6 x 40MM - RBW)		4PCS
2	LOCK WASHER (1/4" x 13Ø - RBW)		4PCS
3	FLAT WASHER (1/4" x 19Ø - RBW)		4PCS
4	WOOD DOWEL (Ø8 x 30MM)		4PCS
5	ALLEN WRENCH (M4 x 110MM - BLK)		1PC

NOTE:

Phillips head screw driver is required in the assembly process; however, manufacturer does not provided this item.

ITEM: **225102**
ASSEMBLY INSTRUCTIONS

STEP 1

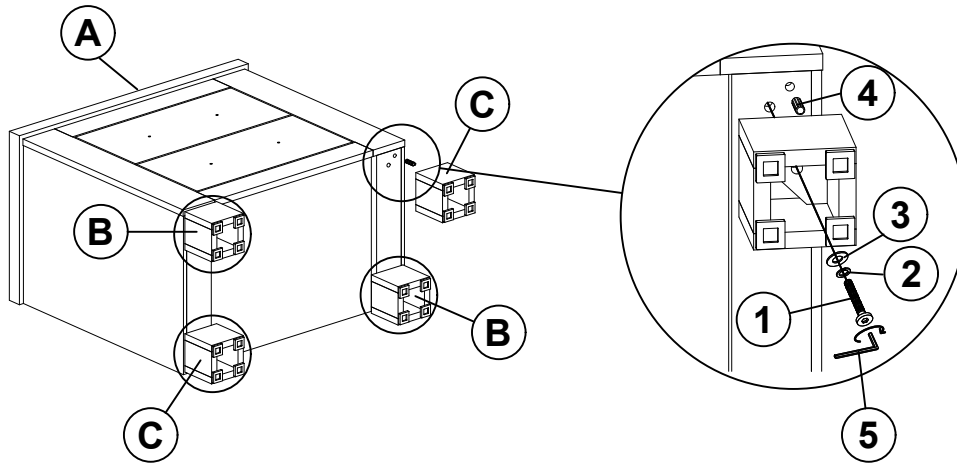

**** BOTTOM VIEW**

STEP 2
COMPLETE

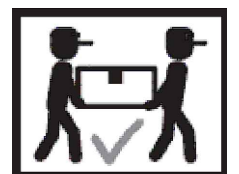
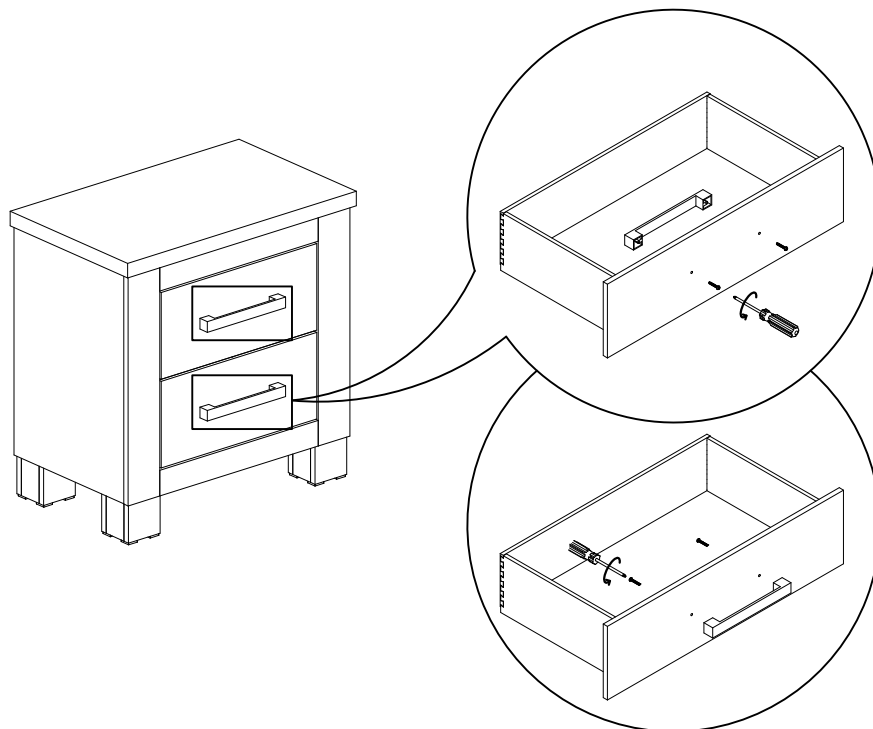

ITEM: **225102**

Inner Size of Drawer : 15.00"W X 12.25"D X 5.00"H X 0.50"T

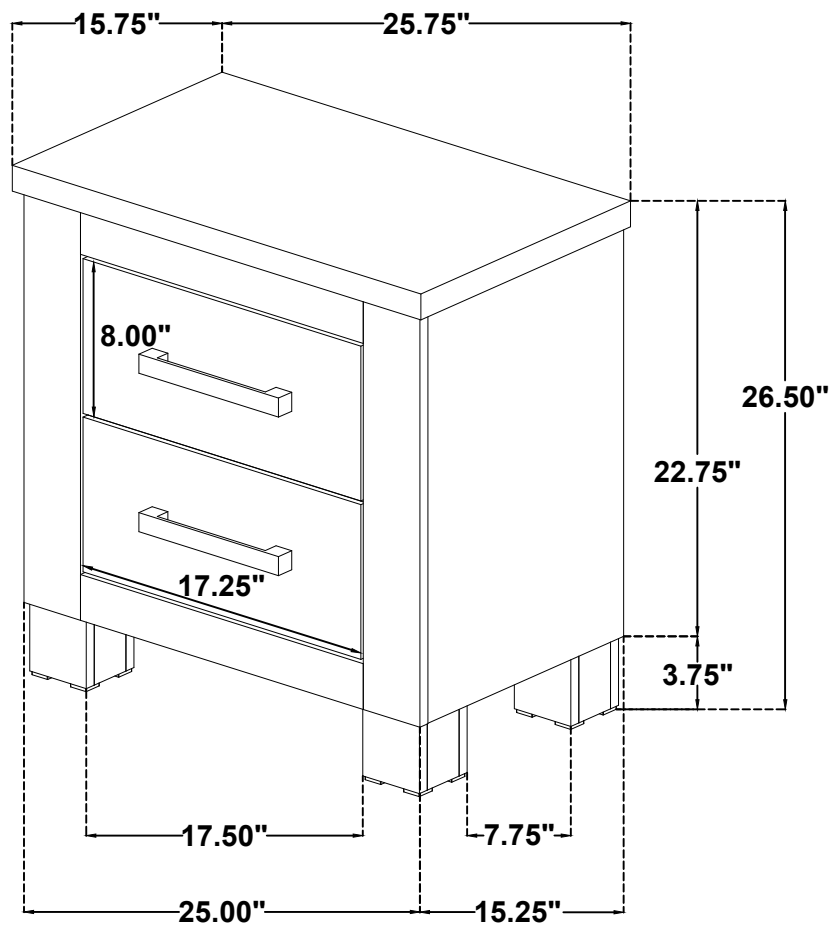

Note : Dimension tolerance $\pm 5\%$

ASSEMBLY INSTRUCTIONS
COASTER FINE FURNITURE



Fine Furniture for every stage of life

225103
Dresser

ITEM: 225103

ASSEMBLY INSTRUCTIONS



ASSEMBLY TIPS:

1. Remove hardware from box and sort by size.
2. Please check to see that all hardware and parts are present prior to start of assembly.
3. Please follow attached instructions in the same sequence as numbered to assure fast & easy assembly.



WARNING!

1. Don't attempt to repair or modify parts that are broken or defective. Please contact the store immediately.
2. This product is for home use only and not intended for commercial establishments.

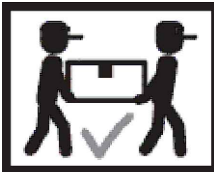

ASSEMBLY TIME

10 MINUTES

PART IDENTIFICATION

A DRESSER

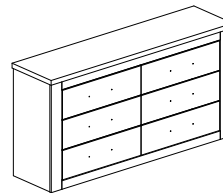

1PC

B LEG (WITH "B" LABEL)



2PCS

C LEG (WITH "C" LABEL)



2PCS

D CENTER LEG SUPPORT WITH LEVELER



1PC

HARDWARE IDENTIFICATION

1 BOLT
(M6 x 40MM - RBW)

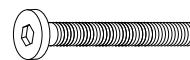

4PCS

2 LOCK WASHER
(1/4" x 13Ø - RBW)



4PCS

3 FLAT WASHER
(1/4" x 19Ø - RBW)



4PCS

4 WOOD DOWEL
(Ø8 x 30MM)

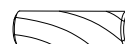

4PCS

5 ALLEN WRENCH
(M4 x 110MM - BLK)



1PC

NOTE:

Phillips head screw driver is required in the assembly process; however, manufacturer does not provided this item.

ITEM: **225103**
ASSEMBLY INSTRUCTIONS

STEP 1

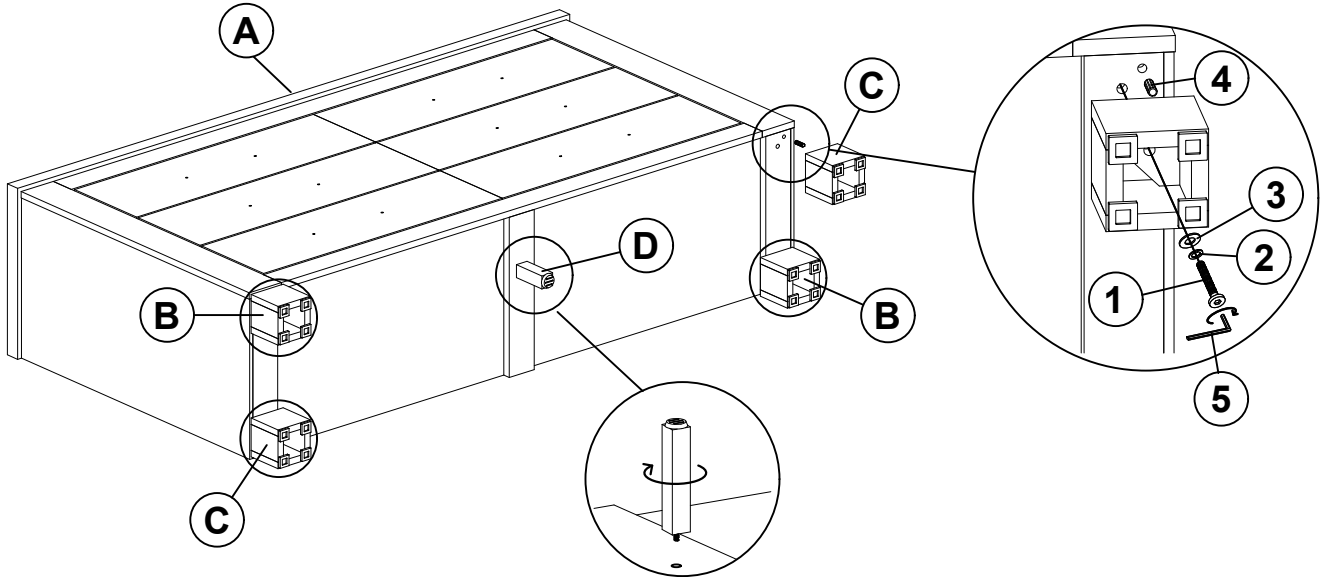

**** BOTTOM VIEW**

STEP 2
COMPLETE

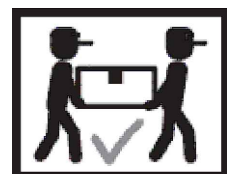
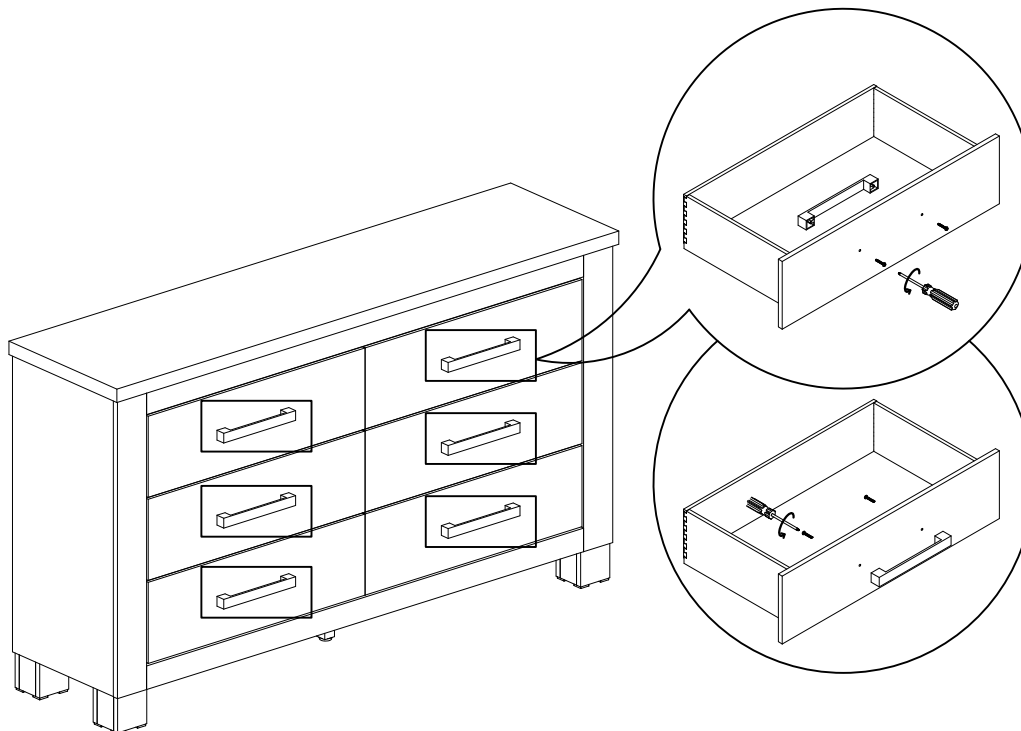

ANTI-TIPPING INSTALLMENT INSTRUCTIONS FURNITURE TIPPING RESTRAINT

WARNING

Injury may result from tipping furniture.

This restraint may protect against tipping furniture.

Do not allow children to climb on furniture.

This restraint is not a substitute for proper adult supervision.

Failure to detach this restraint before moving the furniture may result in injury and damage.

1. Attach one of the mounting brackets securely to the back edge of the unit, using the short screw.
2. determine where the unit is to be placed, and mark the location on the wall for the other mounting bracket. The bracket on the wall needs to be approximately 2" below the bracket mounted to the edge of the unit.
3. Drill a hole in the wall. Insert the plastic wall anchor into the hole and if necessary, use a small block of wood and hammer to tap it in so that it's flush with the wall.
4. Attach the bracket over the plastic wall anchor using the long screw.
5. Place the unit against the wall, both brackets need to be placing each other.
6. Lace an end of the restraint strap through the hole in each bracket. Bring both ends together and rotate the thumb nut onto the threaded end until tight.
7. Ensure that the restraint strap is securely laced and locked.

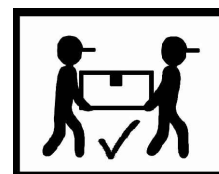
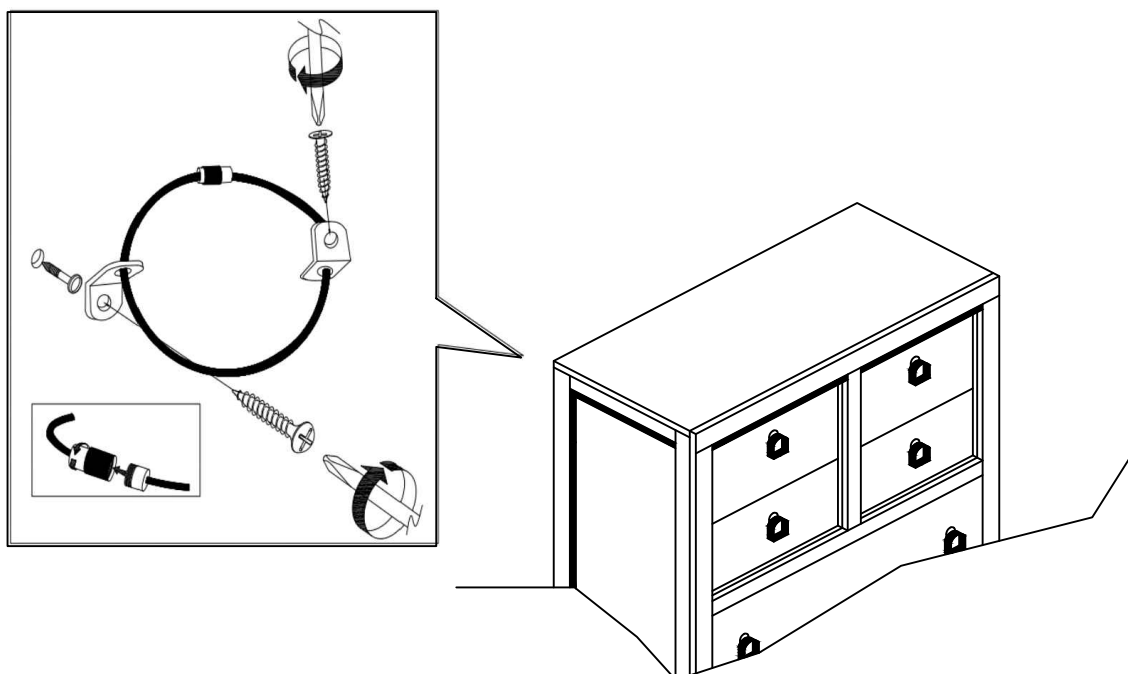

ITEM: **225103**



Inner Size of Drawer : 23.25"W X 12.25"D X 5.00"H X 0.50"T

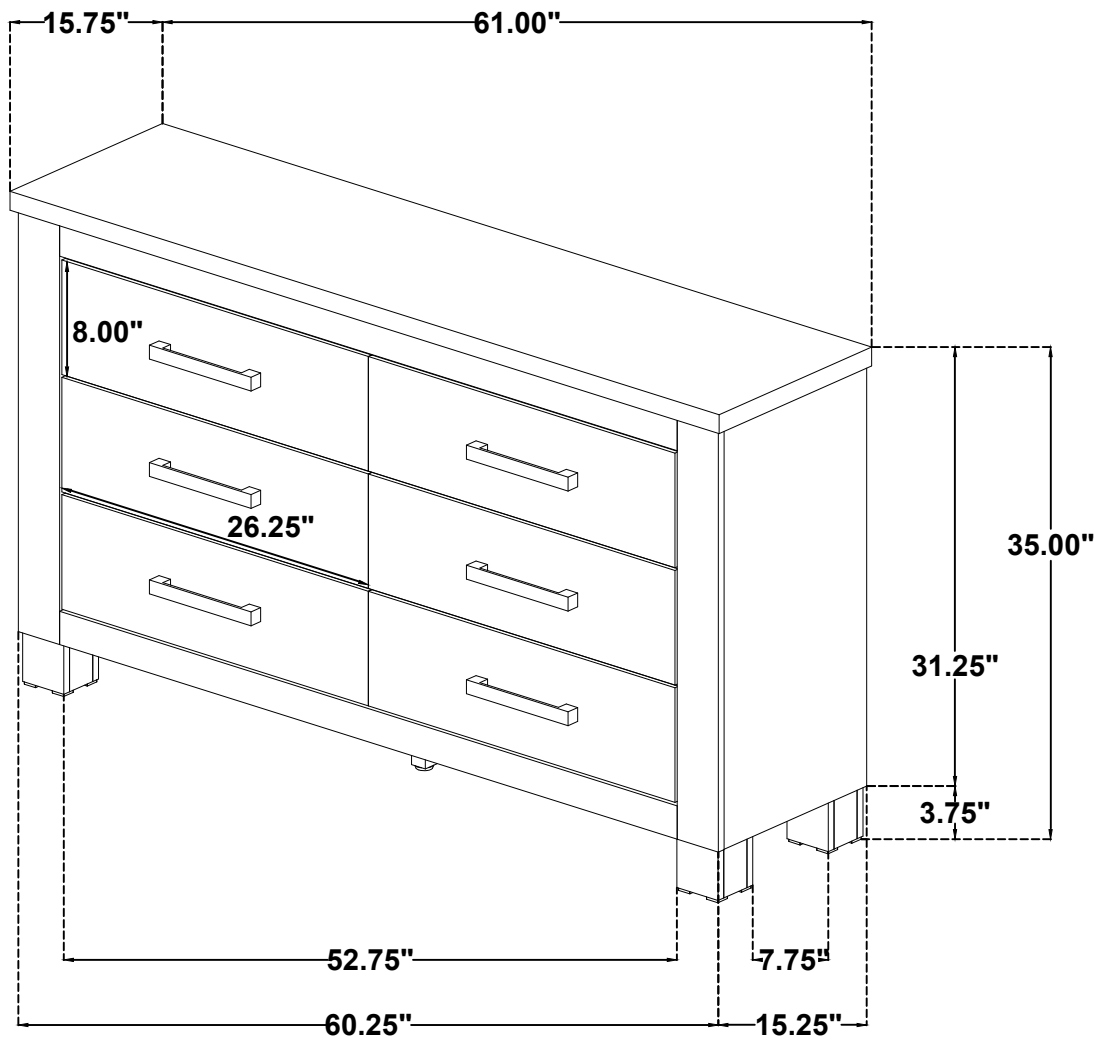

Note : Dimension tolerance $\pm 5\%$

ASSEMBLY INSTRUCTIONS
COASTER FINE FURNITURE

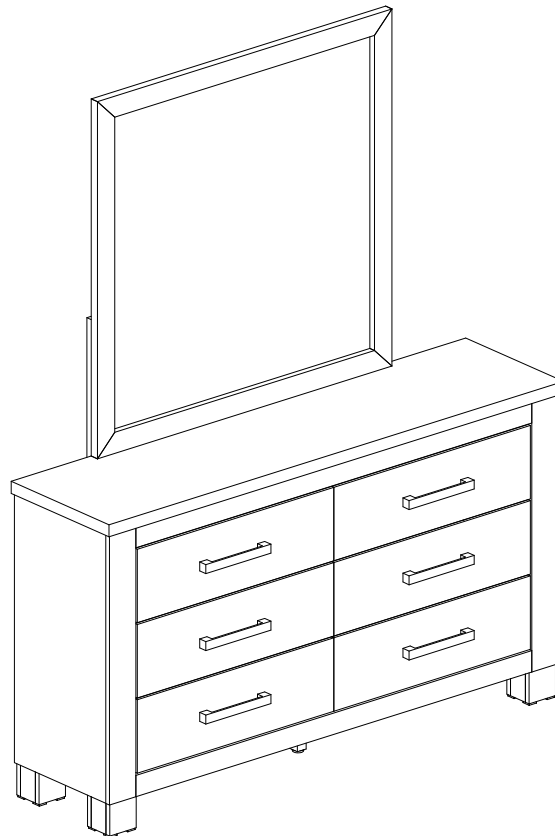

Fine Furniture for every stage of life

225104
Mirror

ITEM: 225104

ASSEMBLY INSTRUCTIONS



ASSEMBLY TIPS:

1. Remove hardware from box and sort by size.
2. Please check to see that all hardware and parts are present prior to start of assembly.
3. Please follow attached instructions in the same sequence as numbered to assure fast & easy assembly.



WARNING!

1. Don't attempt to repair or modify parts that are broken or defective. Please contact the store immediately.
2. This product is for home use only and not intended for commercial establishments.

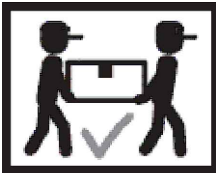

ASSEMBLY TIME

10 MINUTES

PART IDENTIFICATION

A MIRROR

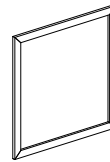

1PC

B MIRROR SUPPORT
(PACKED WITH MIRROR)

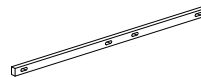

2PCS

C DRESSER
*FROM BOX ITEM 225103

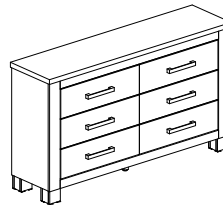

1PC

HARDWARE IDENTIFICATION

1 BOLT
(M6 x 40MM - RBW)

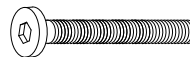

8PCS

2 LOCK WASHER
(1/4" x 13Ø - RBW)



8PCS

3 FLAT WASHER
(1/4" x 19Ø - RBW)



8PCS

4 ALLEN WRENCH
(M4 x 110MM - BLK)



1PC

NOTE:

Phillips head screw driver is required in the assembly process; however, manufacturer does not provided this item.

ITEM: **225104**
ASSEMBLY INSTRUCTIONS



STEP 1

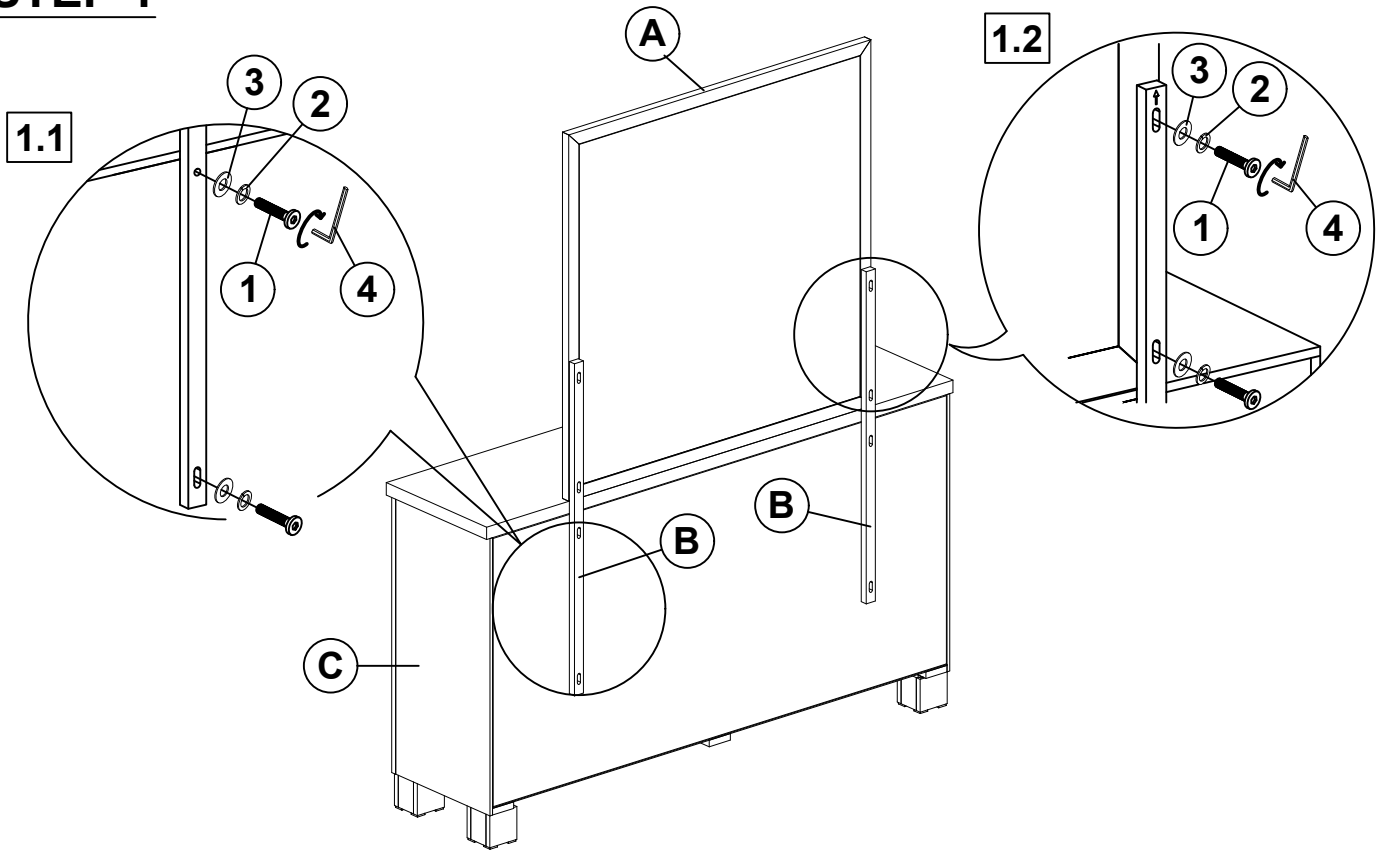

**** BACK VIEW**

STEP 2
COMPLETE

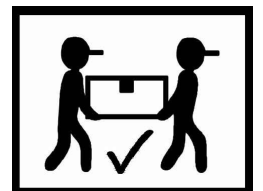
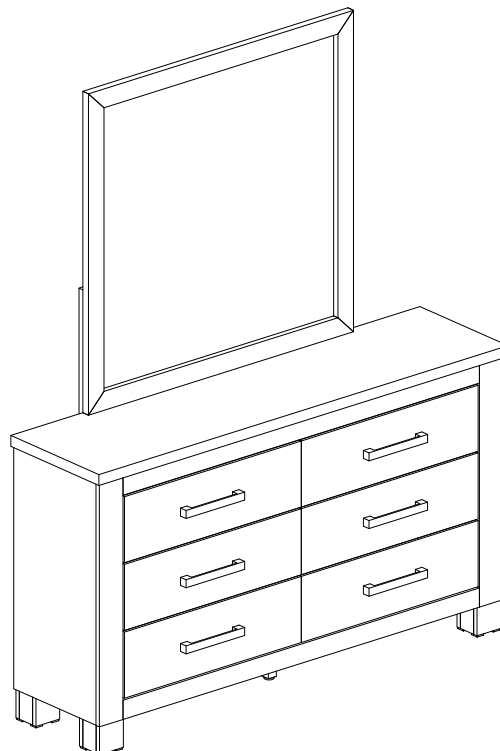

ITEM: **225104**

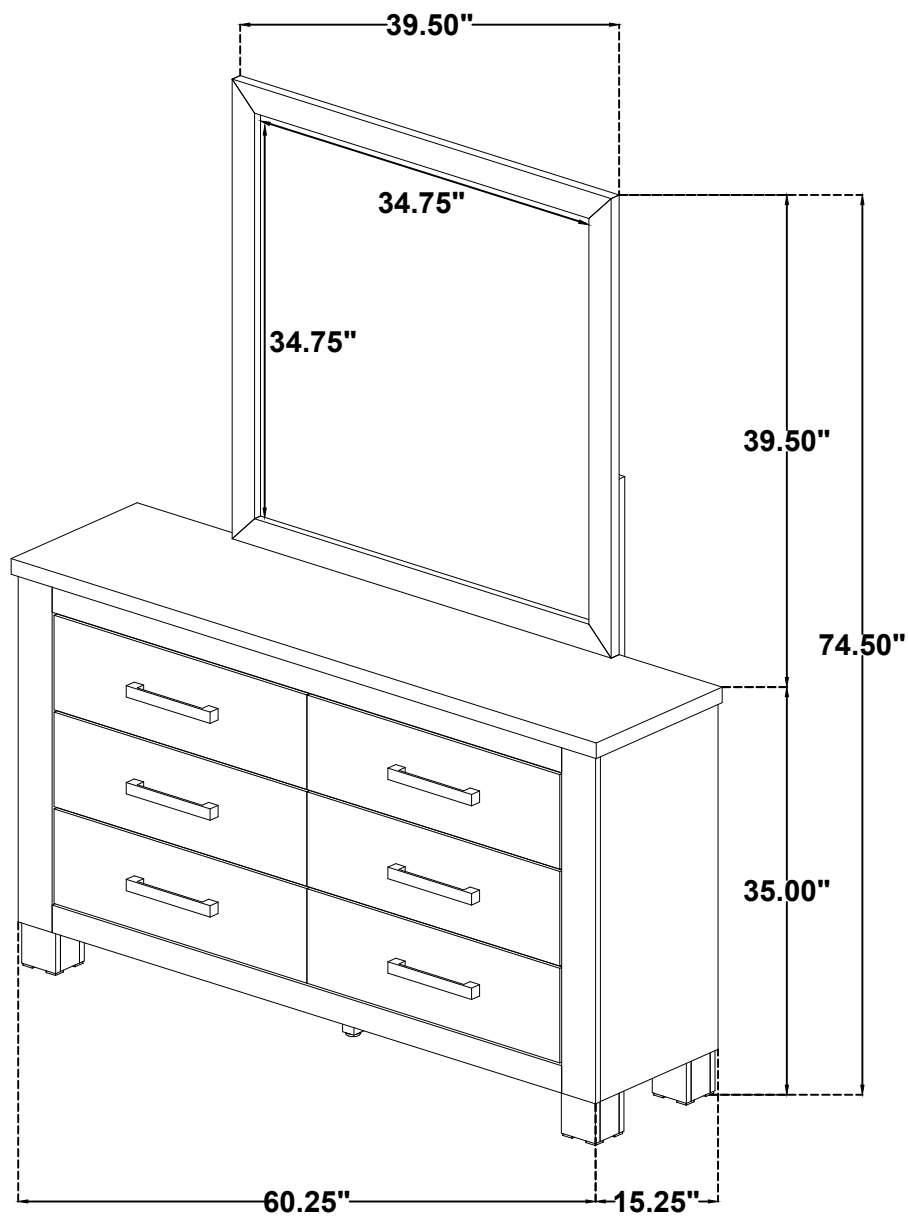

Note : Dimension tolerance $\pm 5\%$