

ASSEMBLY INSTRUCTIONS
COASTER FINE FURNITURE

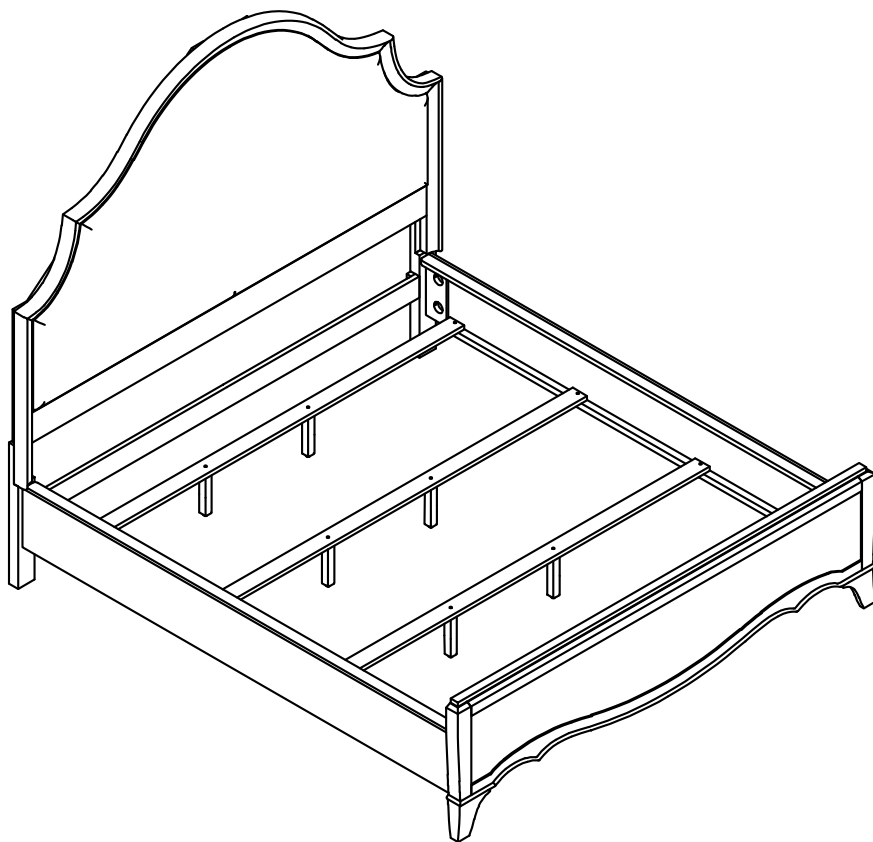

Fine Furniture for every stage of life

225051KW (B1-B3)
California King Bed

ITEM: 225051KW(B1-B3)



ASSEMBLY INSTRUCTIONS

ASSEMBLY TIPS:

1. Remove hardware from box and sort by size.
2. Please check to see that all hardware and parts are present prior to start of assembly.
3. Please follow attached instructions in the same sequence as numbered to assure fast & easy assembly.



WARNING!

1. Don't attempt to repair or modify parts that are broken or defective. Please contact the store immediately.
2. This product is for home use only and not intended for commercial establishments.





ASSEMBLY TIME

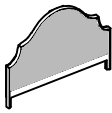
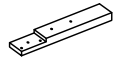
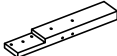

30 MINUTES

PARTS IDENTIFICATION



B1 (BOX 1)

<p>A HEADBOARD PANEL</p>  <p>1PC</p>	<p>B RIGHT HEADBOARD LEG</p>  <p>1PC</p>
<p>C LEFT HEADBOARD LEG</p>  <p>1PC</p>	<p>D HEADBOARD BOTTOM RAIL</p>  <p>1PC</p>

B2 (BOX 2)

<p>E FOOTBOARD PANEL</p>  <p>1PC</p>	<p>F RIGHT FOOTBOARD LEG</p>  <p>1PC</p>
<p>G LEFT FOOTBOARD LEG</p>  <p>1PC</p>	

B3 (BOX 3)

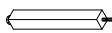
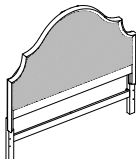
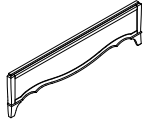
<p>H BED RAIL</p>  <p>2PCS</p>	<p>I BED SLAT</p>  <p>4PCS</p>
<p>J BED SLAT SUPPORT WITH LEVELER</p>  <p>8PCS</p>	
<p>HB 225051 KW(B1) FROM BOX 1 HEADBOARD COMPLETE</p>  <p>1PC</p>	<p>FB 225051 KW(B2) FROM BOX 2 FOOTBOARD COMPLETE</p>  <p>1PC</p>

NOTE:

Phillips head screw driver is required in the assembly process; however, manufacturer does not provide this item.

ITEM: 225051KW(B1-B3)



ASSEMBLY INSTRUCTIONS

ASSEMBLY TIPS:

1. Remove hardware from box and sort by size.
2. Please check to see that all hardware and parts are present prior to start of assembly.
3. Please follow attached instructions in the same sequence as numbered to assure fast & easy assembly.





WARNING!







1. Don't attempt to repair or modify parts that are broken or defective. Please contact the store immediately.
2. This product is for home use only and not intended for commercial establishments.

HARDWARE IDENTIFICATION





Z-B1(BOX 1)- HARDWARE PACK IS LOCATED IN 225051KW(B1)

1	BOLT (\varnothing 5/16" x 50MM- RBW)		10PCS	3	FLAT WASHER (\varnothing 5/16" - RBW)		10PCS
2	LOCK WASHER (\varnothing 5/16" - RBW)		10PCS	4	ALLEN WRENCH (4MM x 60MM - RBW)		1PC

Z-B2(BOX2)- HARDWARE PACK IS LOCATED IN 225051KW(B2)

5	BOLT (\varnothing 5/16" x 50MM- RBW)		4PCS	7	FLAT WASHER (\varnothing 5/16" - RBW)		4PCS
6	LOCK WASHER (\varnothing 5/16" - RBW)		4PCS	8	ALLEN WRENCH (4MM x 60MM - RBW)		1PC

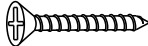
Z-B3 (BOX 3) - HARDWARE PACK IS LOCATED IN 225051KW(B3)

9	THREADED BOLT (\varnothing 5/16" x 90MM - RBW)		8PCS	12	WRENCH (14MM - RBW)		1PC
10	HALF ROUND NUT (\varnothing 5/16" - RBW)		8PCS	13	FLAT HEAD SCREW (\varnothing 4 x 30MM - RBW)		8PCS
11	HEX NUT (\varnothing 5/16" x 14MM - RBW)		8PCS				

NOTE:

Phillips head screw driver is required in the assembly process; however, manufacturer does not provide this item.

ITEM: 225051KW(B1-B3)

ASSEMBLY INSTRUCTIONS

STEP 1

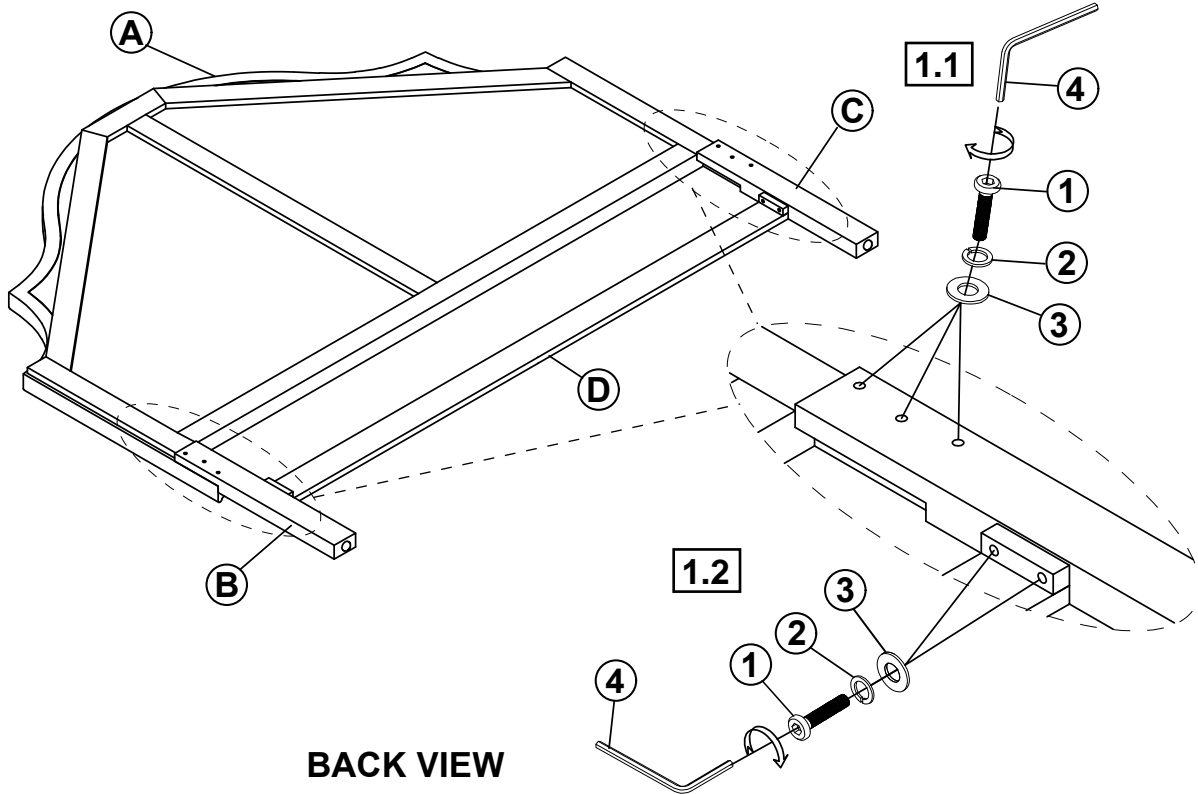

STEP 2

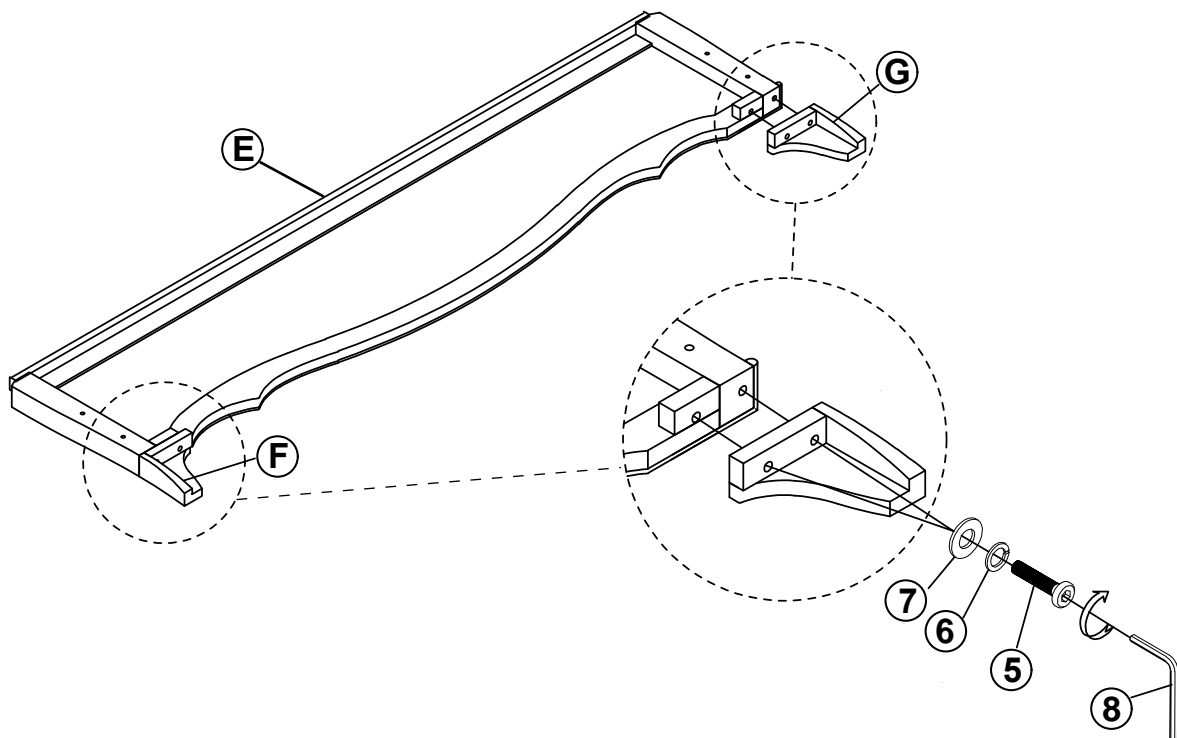

ITEM: 225051KW(B1-B3)

ASSEMBLY INSTRUCTIONS

STEP 3

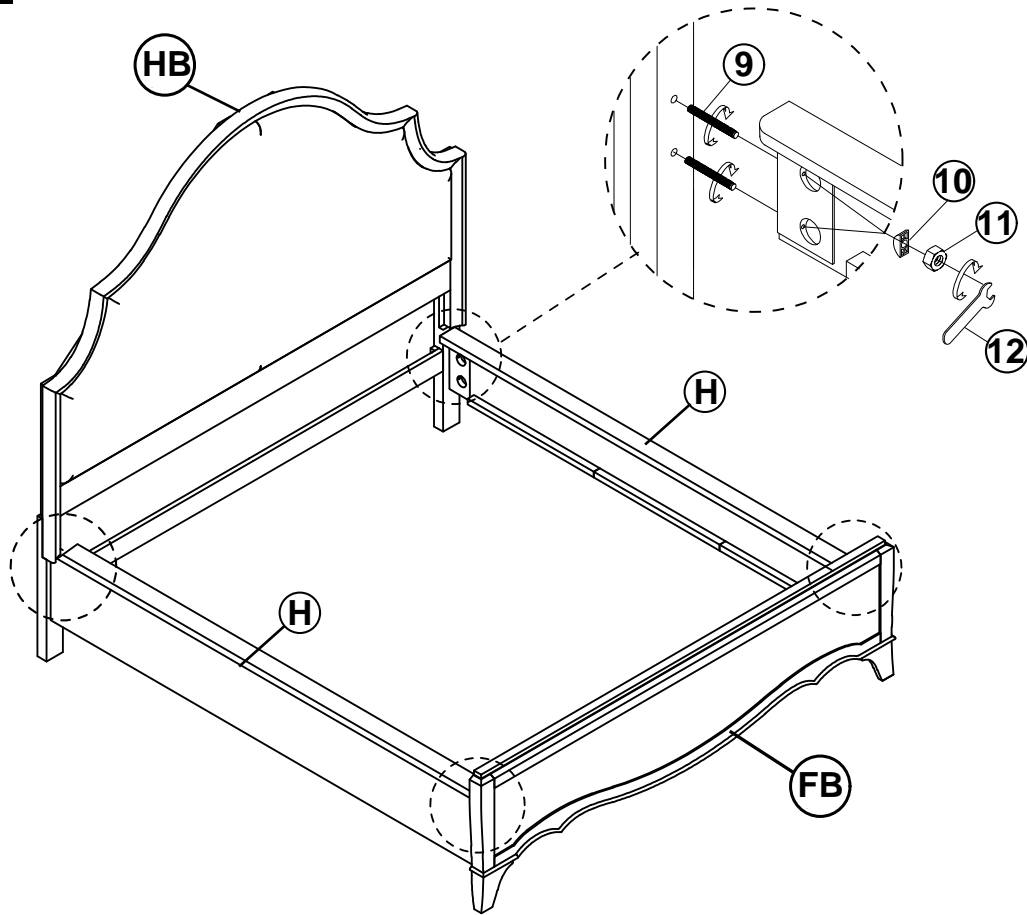

STEP 4

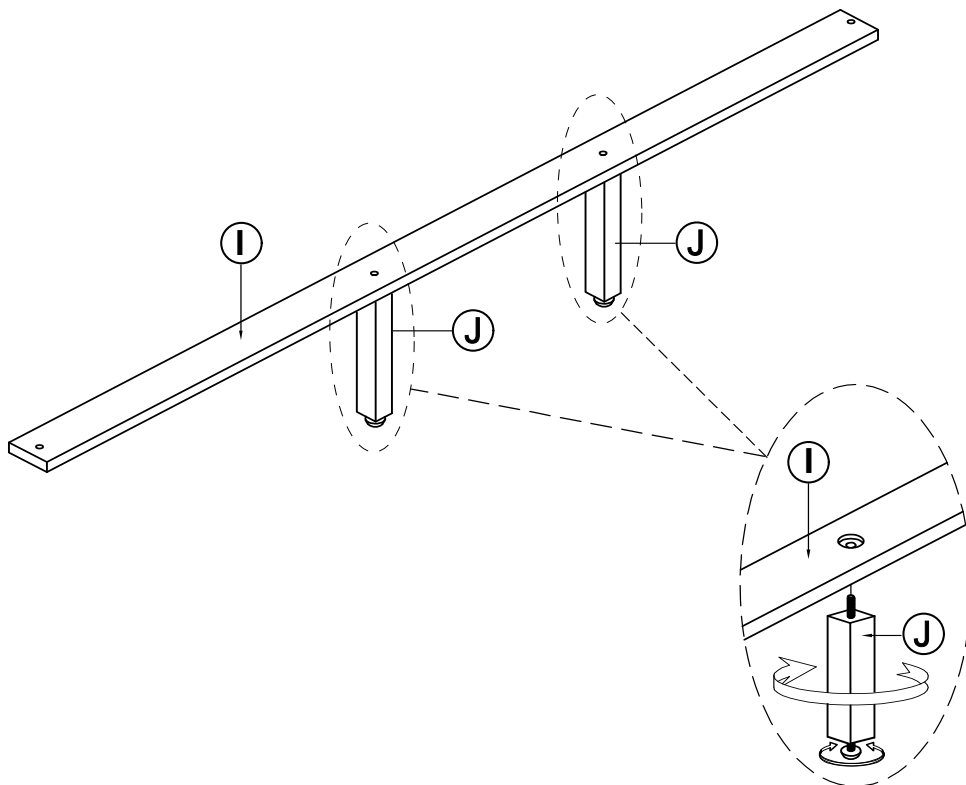

ITEM: **225051KW(B1-B3)**

ASSEMBLY INSTRUCTIONS

STEP 5

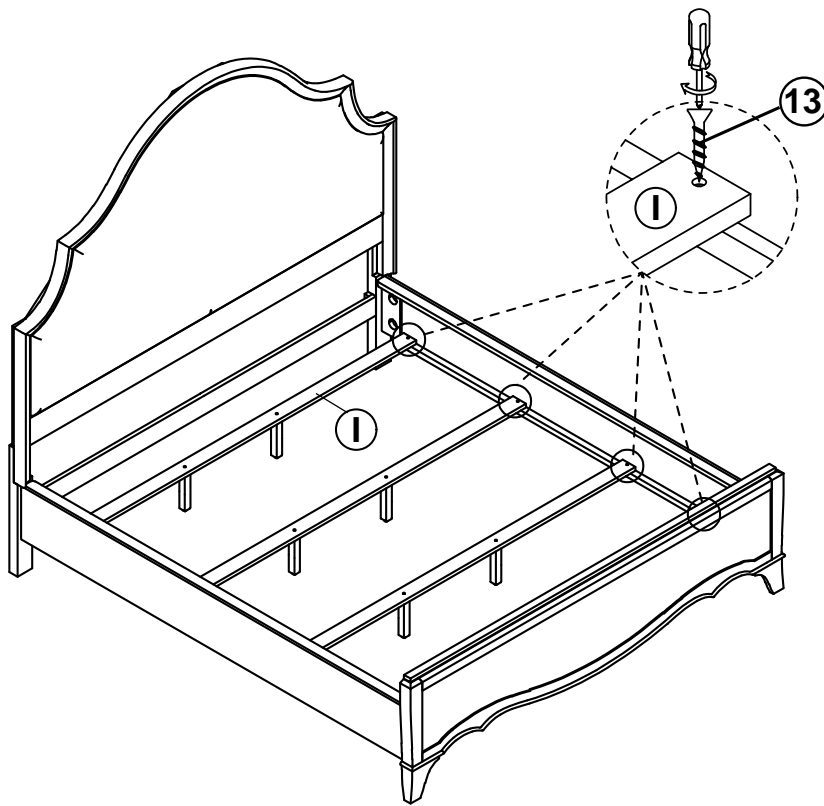

STEP 6

COMPLETE

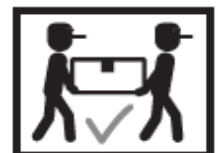
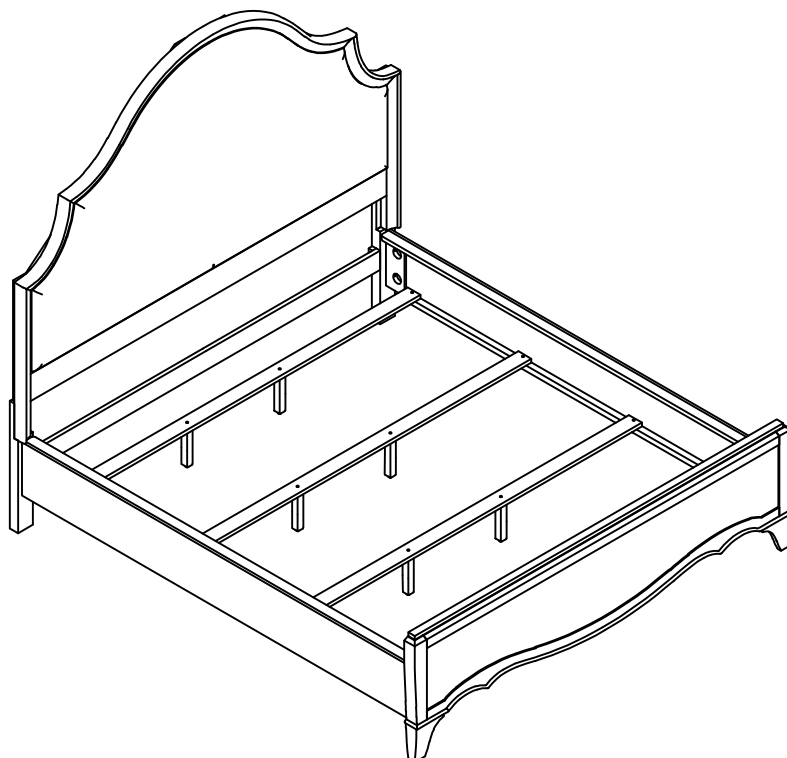

ITEM: **225051KW(B1-B3)**



Inner Size : 85.00"W X 73.00"D

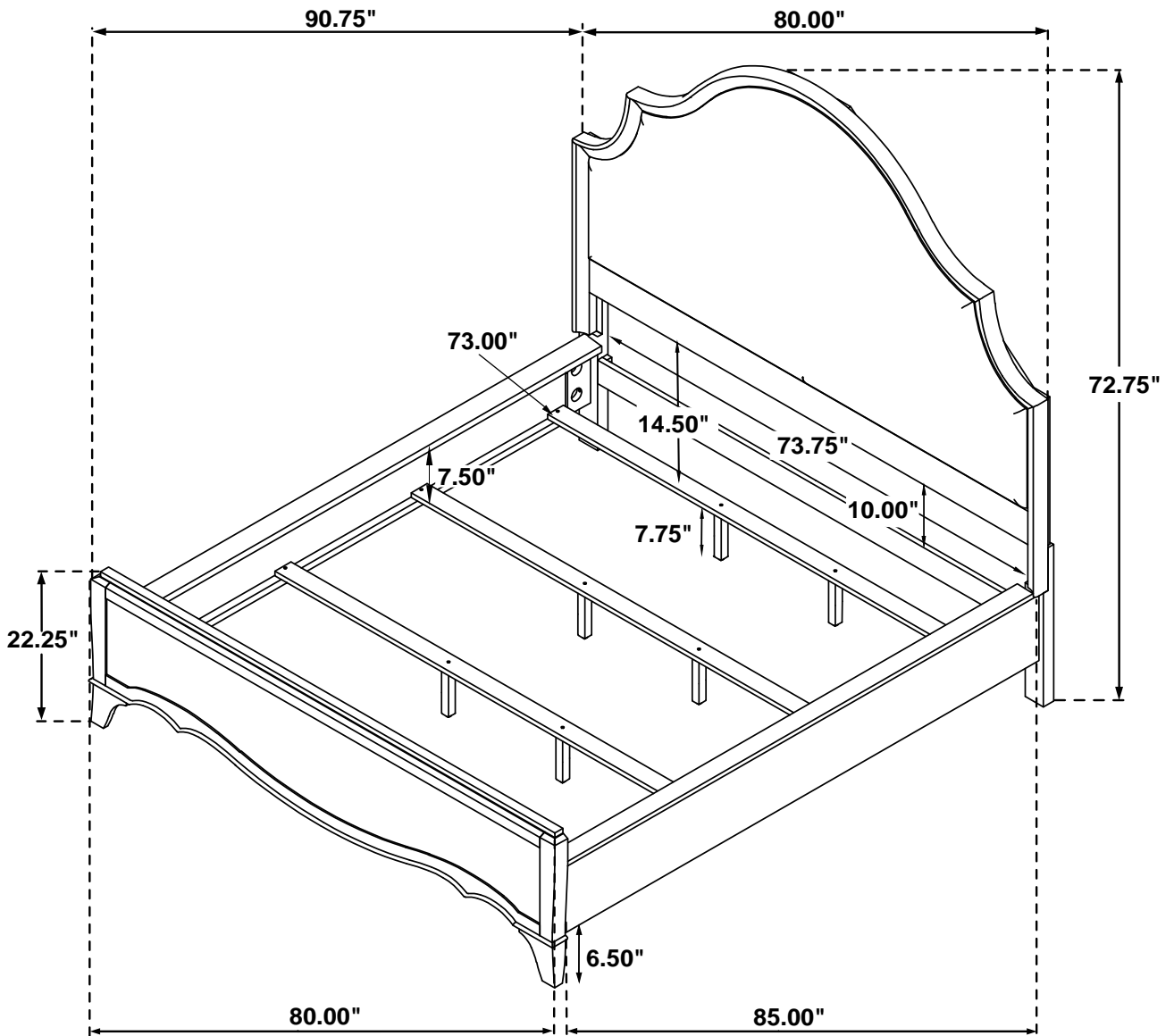

Note: Dimension tolerance $\pm 5\%$



ASSEMBLY INSTRUCTIONS
COASTER FINE FURNITURE



Fine Furniture for every stage of life

225052
Nightstand

ITEM: **225052**



ASSEMBLY INSTRUCTIONS

ASSEMBLY TIPS:

1. Remove hardware from box and sort by size.
2. Please check to see that all hardware and parts are present prior to start of assembly.
3. Please follow attached instructions in the same sequence as numbered to assure fast & easy assembly.



WARNING!





1. Don't attempt to repair or modify parts that are broken or defective. Please contact the store immediately.
2. This product is for home use only and not intended for commercial establishments.





ASSEMBLY TIME

5 MINUTES

PARTS IDENTIFICATION

A	NIGHTSTAND		1PC	B	RIGHT FRONT LEG		1PC
C	LEFT FRONT LEG		1PC	D	RIGHT BACK LEG		1PC
E	LEFT BACK LEG		1PC				

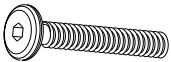
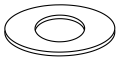
HARDWARE IDENTIFICATION

1	BOLT (Φ5/16" x 45mm - RBW)		8PCS	3	FLAT WASHER (Φ5/16" - RBW)		8PCS
2	LOCK WASHER (Φ5/16" - RBW)		8PCS	4	ALLEN WRENCH (4MM x 60MM - RBW)		1PC

ITEM: **225052**

ASSEMBLY INSTRUCTIONS



STEP 1

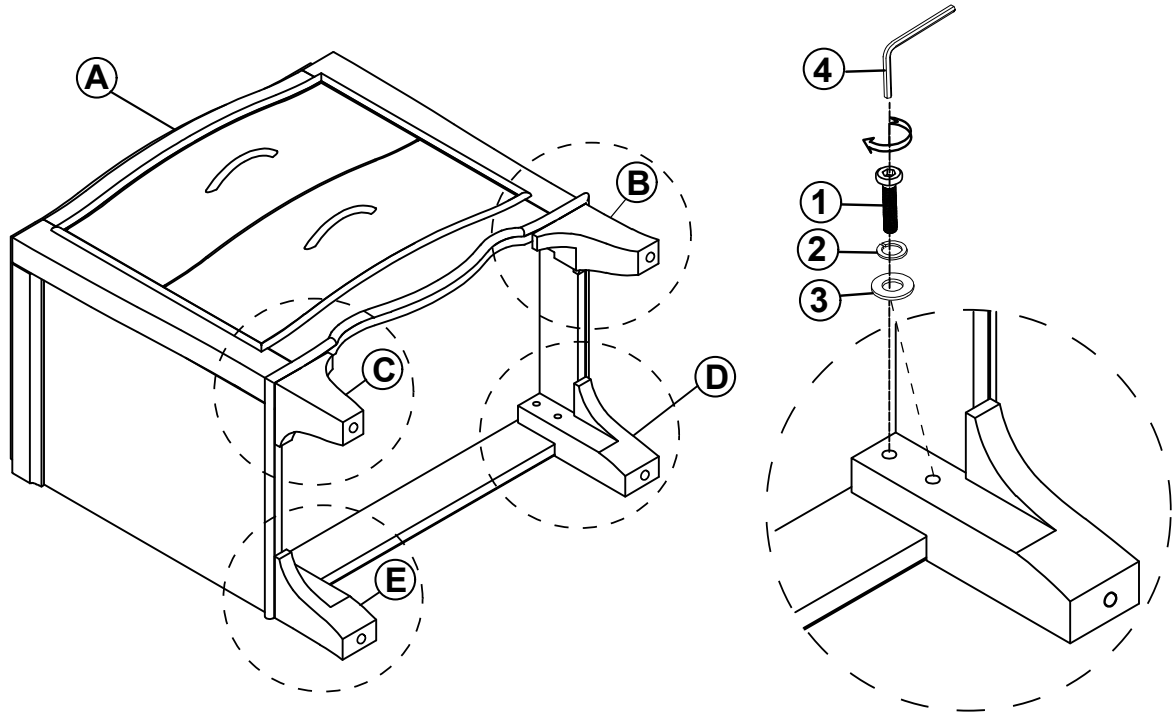

STEP 2
COMPLETE

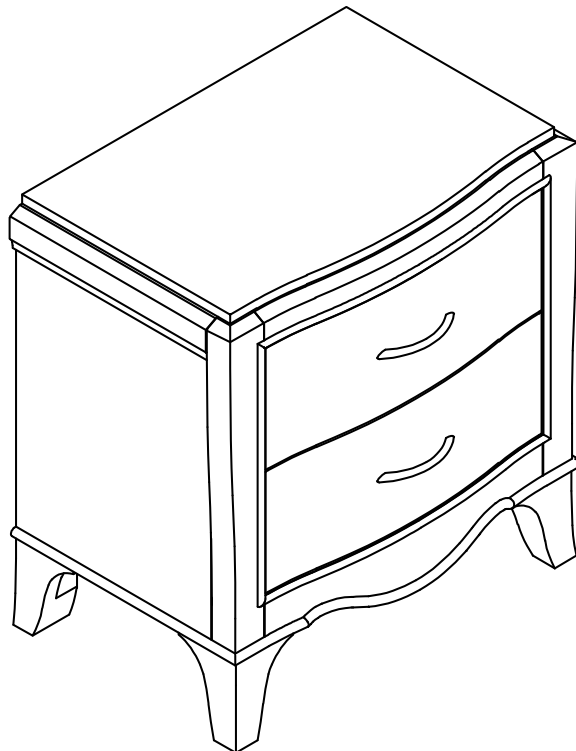

ITEM:225052



Inner Size of Drawer : 19.25"W X 13.50"D X 6.00"H X 0.50"T

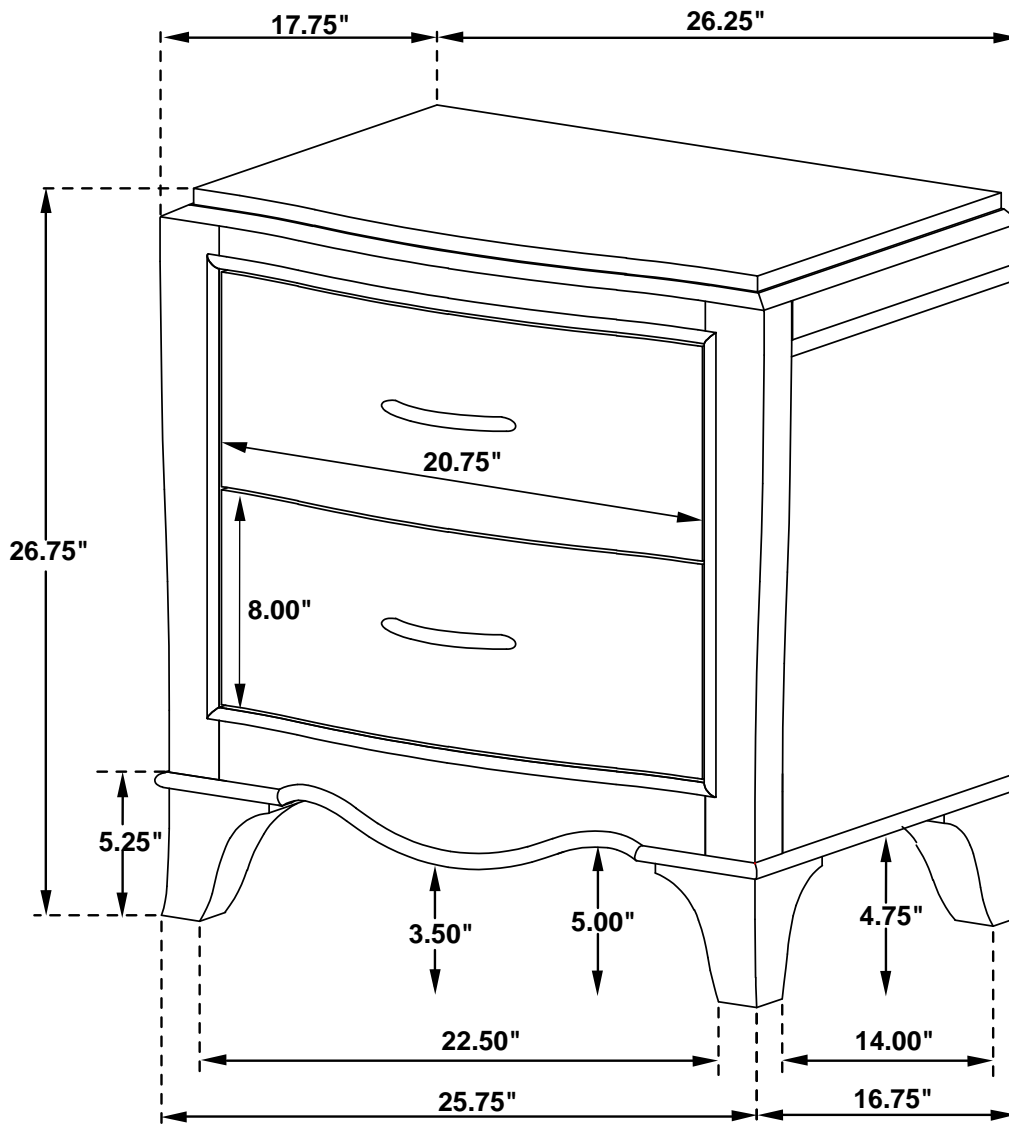

Note: Dimension tolerance $\pm 5\%$



ASSEMBLY INSTRUCTIONS COASTER FINE FURNITURE



Fine Furniture for every stage of life

225053
Dresser

ITEM: **225053**



ASSEMBLY INSTRUCTIONS

ASSEMBLY TIPS:

1. Remove hardware from box and sort by size.
2. Please check to see that all hardware and parts are present prior to start of assembly.
3. Please follow attached instructions in the same sequence as numbered to assure fast & easy assembly.



WARNING!







1. Don't attempt to repair or modify parts that are broken or defective. Please contact the store immediately.
2. This product is for home use only and not intended for commercial establishments.



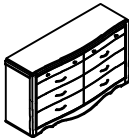



ASSEMBLY TIME

5 MINUTES

PARTS IDENTIFICATION

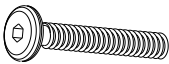
A	DRESSER		1PC	B	RIGHT FRONT LEG		1PC
C	LEFT FRONT LEG		1PC	D	RIGHT BACK LEG		1PC
E	LEFT BACK LEG		1PC	F	CENTER SUPPORT LEG WITH LEVELER		1PC

HARDWARE IDENTIFICATION

1	BOLT (Φ5/16" x 45mm - RBW)		8PCS	3	FLAT WASHER (Φ5/16" - RBW)		8PCS
2	LOCK WASHER (Φ5/16" - RBW)		8PCS	4	ALLEN WRENCH (4MM x 60MM - RBW)		1PC

ITEM: **225053**

ASSEMBLY INSTRUCTIONS

STEP 1

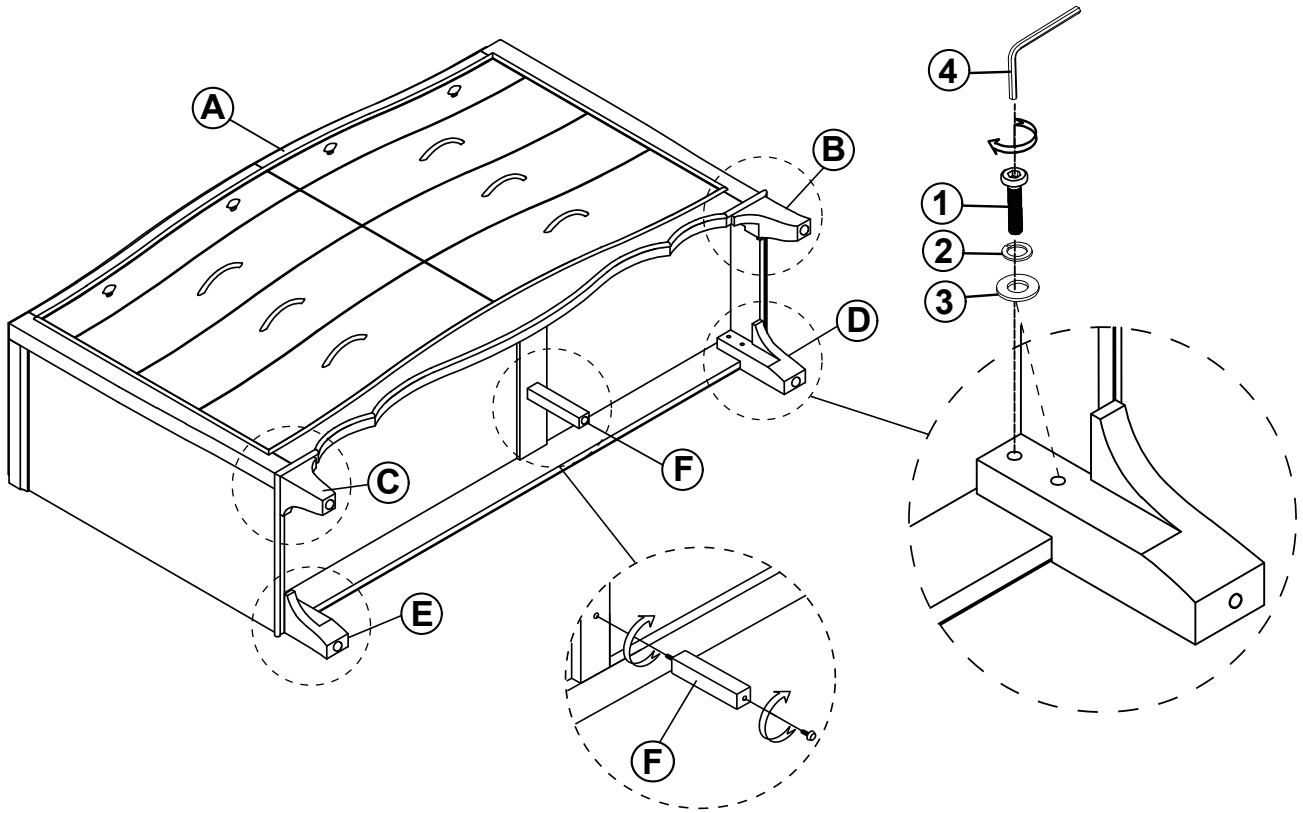

STEP 2
COMPLETE



ANTI-TIPPING INSTALLATION INSTRUCTIONS

FURNITURE TIPPING RESTRAINT

WARNING

Injury may result from tipping furniture.

This restraint may protect against tipping furniture.

Do not allow children to climb on furniture.

This restraint is not a substitute for proper adult supervision.

Failure to detach this restraint before moving the furniture may result in injury and damage.

1. Attach one of the mounting brackets securely to the back edge of the unit, using the short screw.
2. Determine where the unit is to be placed, and mark the location on the wall for the other mounting bracket. The bracket on the wall needs to be approximately 2" below the bracket mounted to the edge of the unit.
3. Drill a hole in the wall. Insert the plastic wall anchor into the hole and if necessary, use a small block of wood and hammer to tap it in so that it's flush with the wall.
4. Attach the bracket over the plastic wall anchor using the long screw.
5. Place the unit against the wall, both brackets need to be facing each other.
6. Lace an end of the restraint strap through the hole in each bracket. Bring both ends together and rotate the thumb nut onto the threaded end until tight.
7. Ensure that the restraint strap is securely laced and locked.

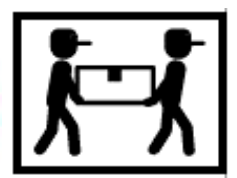
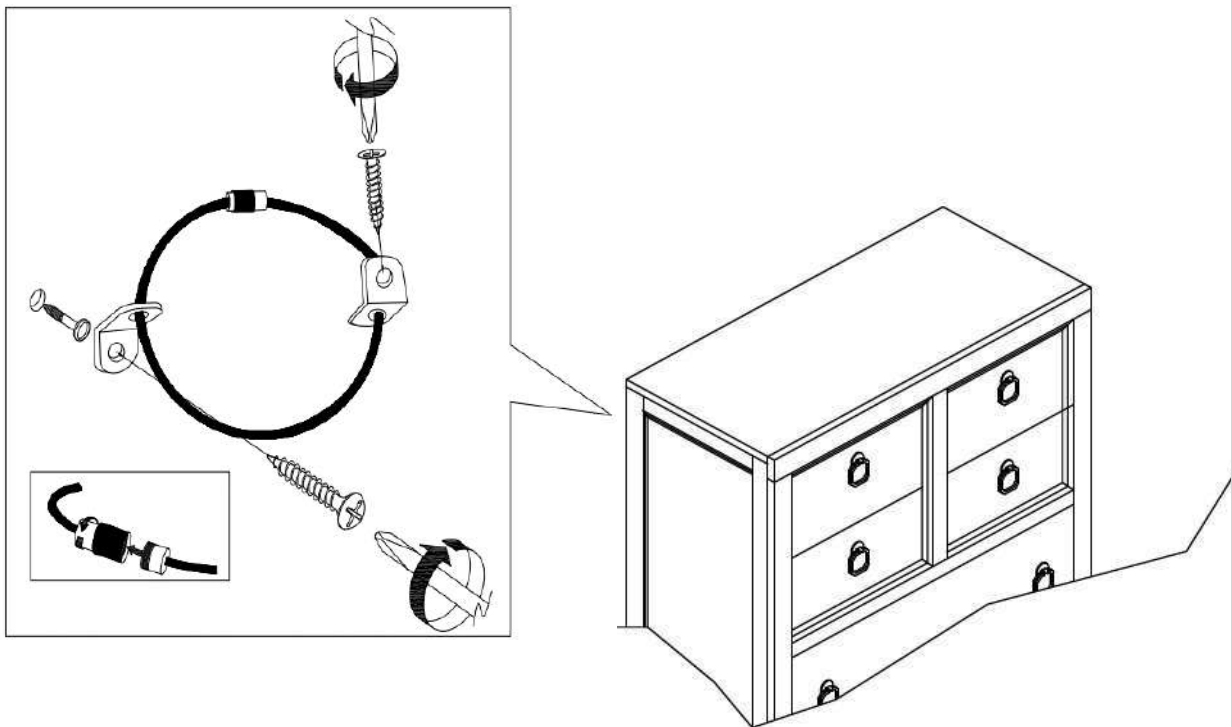

ITEM:225053



Inner Size of Drawer A : 27.25"W X 14.00"D X 2.50"H X 0.50"T
Inner Size of Drawer B : 27.25"W X 14.00"D X 6.00"H X 0.50"T
Inner Size of Drawer C : 27.25"W X 14.00"D X 6.00"H X 0.50"T

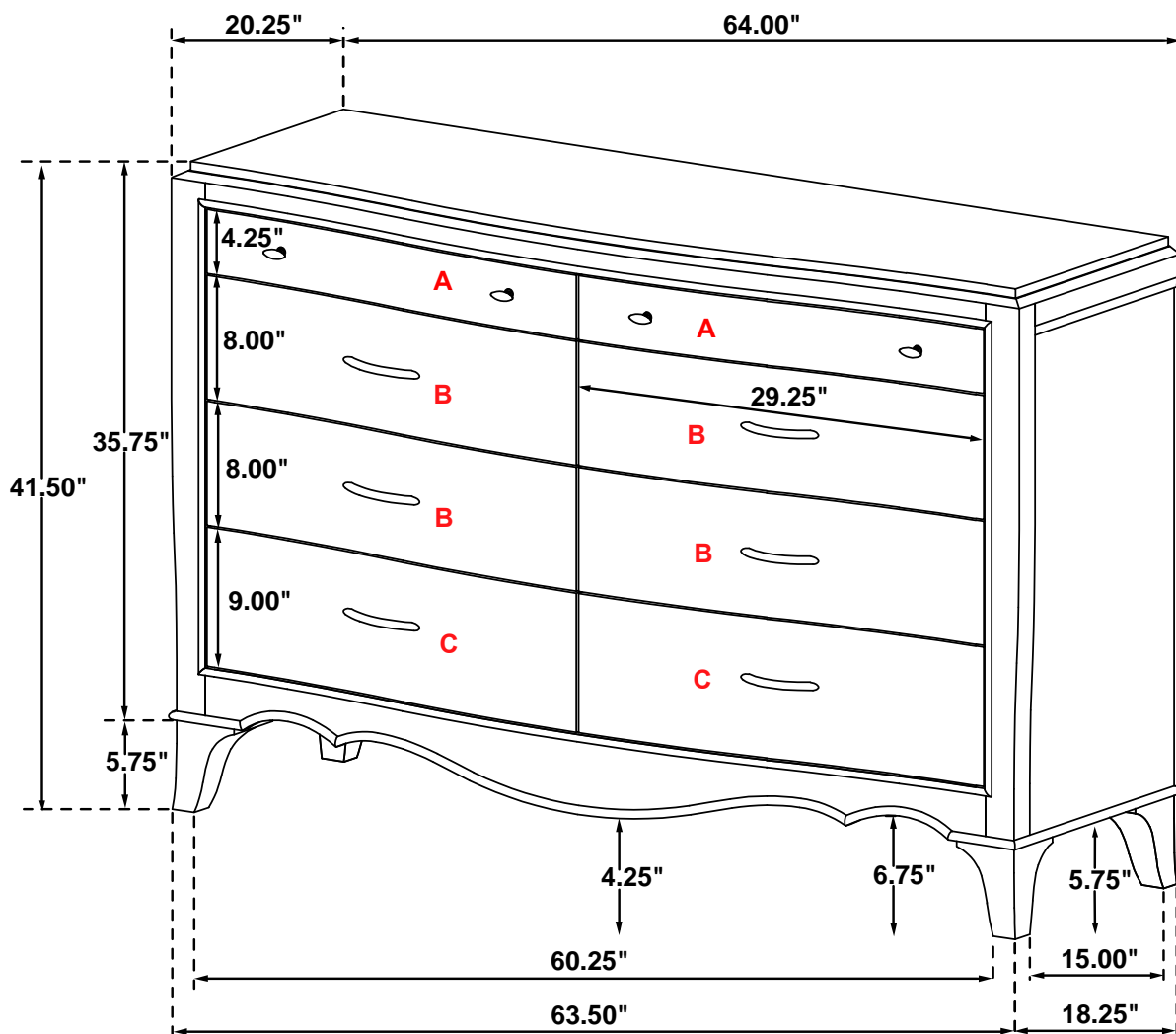

Note: Dimension tolerance $\pm 5\%$

ASSEMBLY INSTRUCTIONS
COASTER FINE FURNITURE

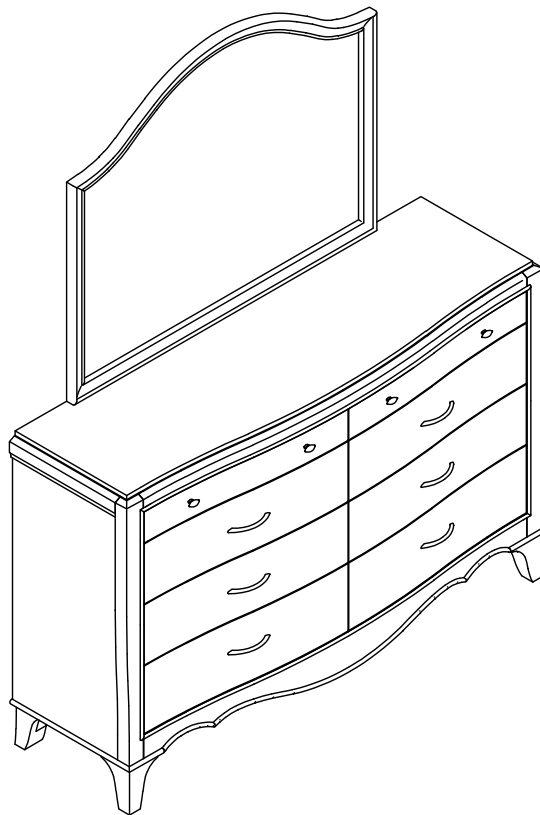

Fine Furniture for every stage of life

225054
Mirror

ITEM: **225054**



ASSEMBLY INSTRUCTIONS

ASSEMBLY TIPS:

1. Remove hardware from box and sort by size.
2. Please check to see that all hardware and parts are present prior to start of assembly.
3. Please follow attached instructions in the same sequence as numbered to assure fast & easy assembly.



WARNING!

1. Don't attempt to repair or modify parts that are broken or defective. Please contact the store immediately.
2. This product is for home use only and not intended for commercial establishments.



ASSEMBLY TIME

5 MINUTES

PARTS IDENTIFICATION

A **DRESSER
FROM BOX
ITEM #225053**



1PC

B **MIRROR**

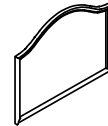

1PC

C **MIRROR SUPPORT
(PACKED WITH DRESSER)**



2PCS

HARDWARE IDENTIFICATION

1 **BOLT
(Φ 1/4" x 38mm - RBW)**

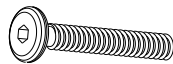

6PCS

3 **FLAT WASHER
(Φ 1/4" - RBW)**



6PCS

2 **LOCK WASHER
(Φ 1/4" - RBW)**

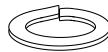

6PCS

4 **ALLEN WRENCH
(4MM x 60MM - RBW)**



1PC

ITEM: **225054**

ASSEMBLY INSTRUCTIONS

STEP 1

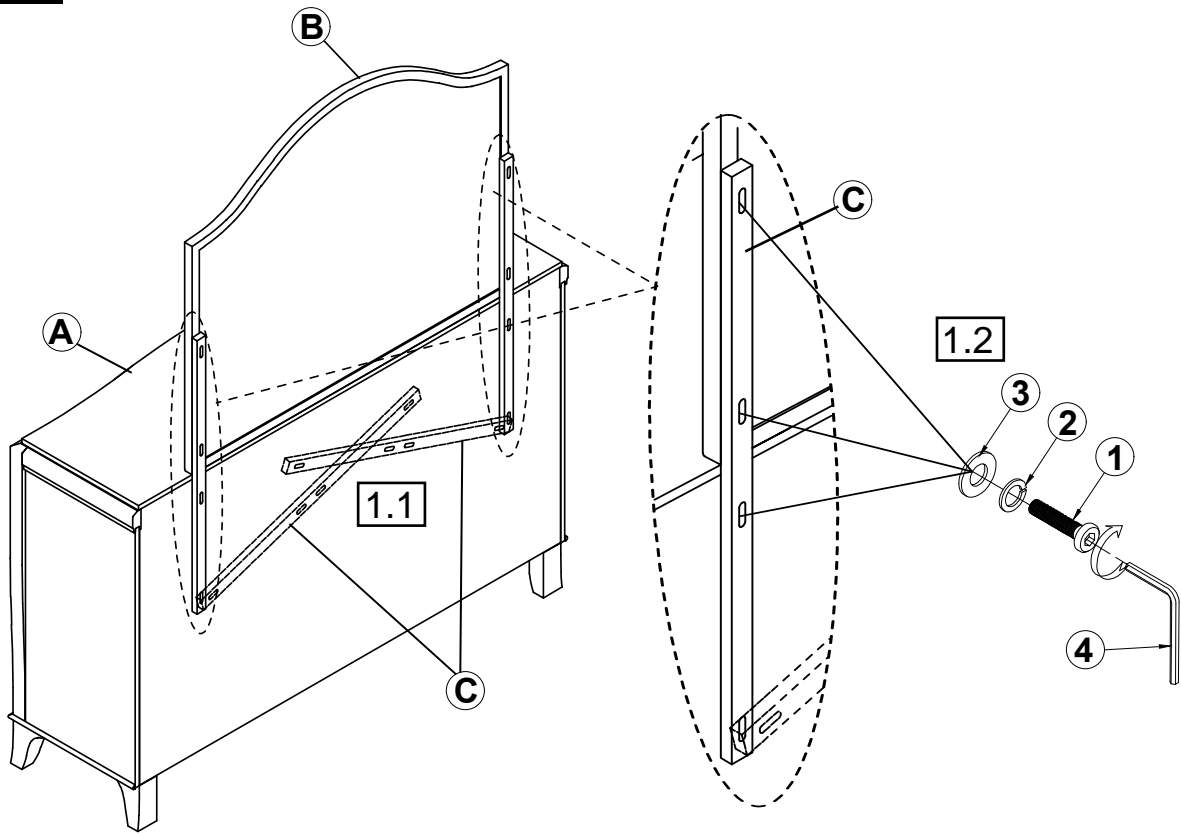

STEP 2
COMPLETE

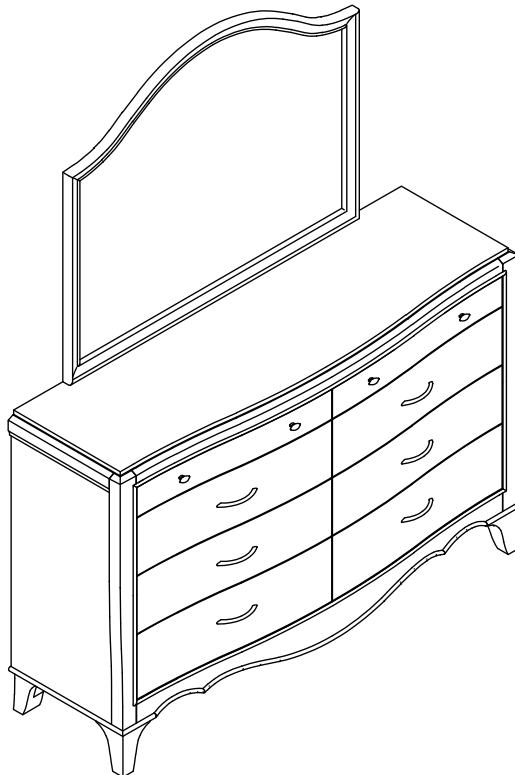

ITEM:225054

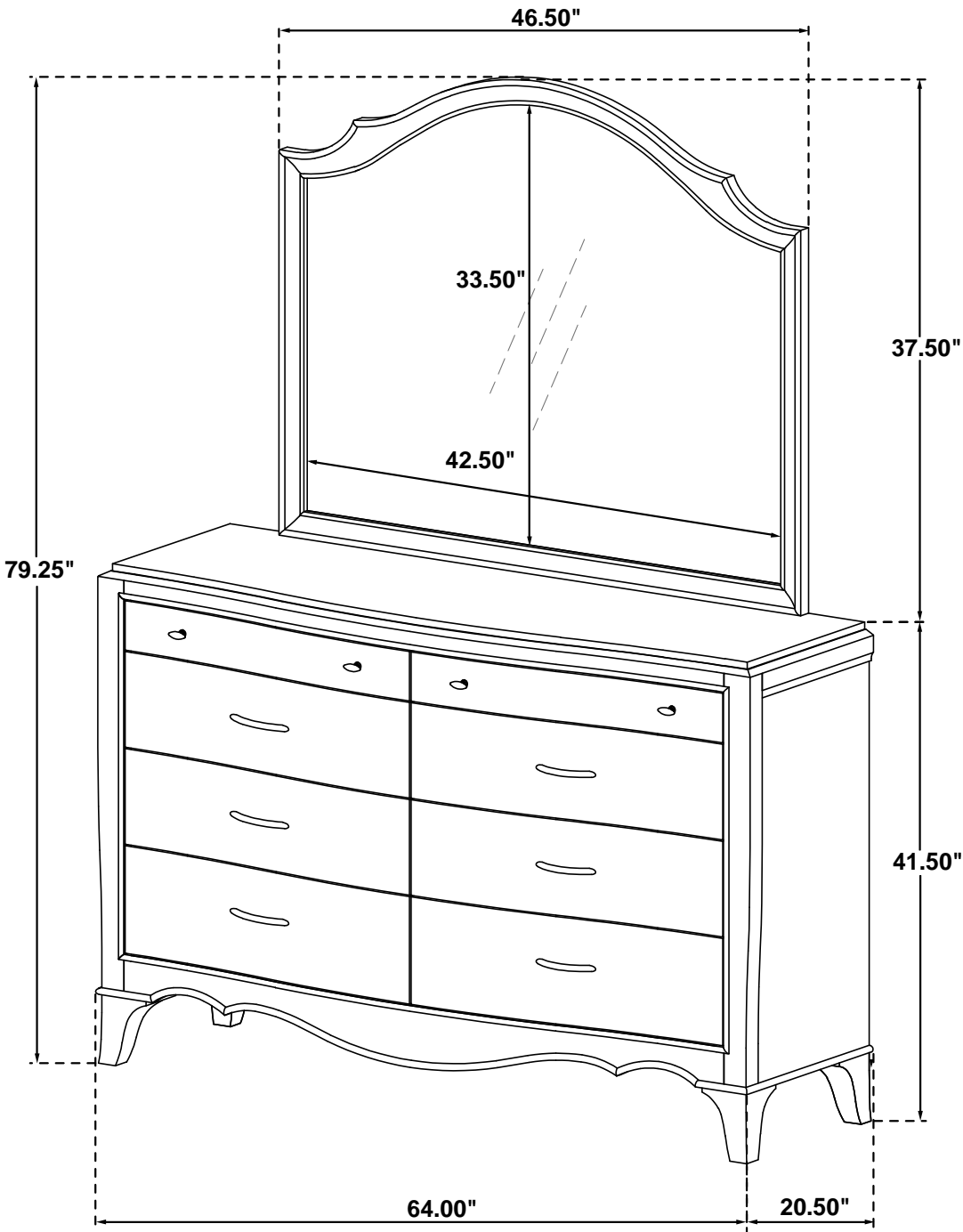

Note: Dimension tolerance $\pm 5\%$



ASSEMBLY INSTRUCTIONS COASTER FINE FURNITURE



Fine Furniture for every stage of life

225055
Chest

ITEM: **225055**



ASSEMBLY INSTRUCTIONS

ASSEMBLY TIPS:

1. Remove hardware from box and sort by size.
2. Please check to see that all hardware and parts are present prior to start of assembly.
3. Please follow attached instructions in the same sequence as numbered to assure fast & easy assembly.



WARNING!





1. Don't attempt to repair or modify parts that are broken or defective. Please contact the store immediately.
2. This product is for home use only and not intended for commercial establishments.





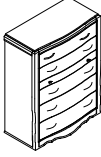

ASSEMBLY TIME

5 MINUTES

PARTS IDENTIFICATION

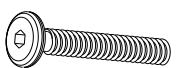
A	CHEST		1PC	B	RIGHT FRONT LEG		1PC
C	LEFT FRONT LEG		1PC	D	RIGHT BACK LEG		1PC
E	LEFT BACK LEG		1PC				

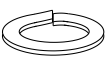
HARDWARE IDENTIFICATION

1	BOLT (Φ 5/16" x 45mm - RBW)		8PCS	3	FLAT WASHER (Φ 5/16" - RBW)		8PCS
2	LOCK WASHER (Φ 5/16" - RBW)		8PCS	4	ALLEN WRENCH (4MM x 60MM - RBW)		1PC

ITEM: **225055**

ASSEMBLY INSTRUCTIONS

STEP 1

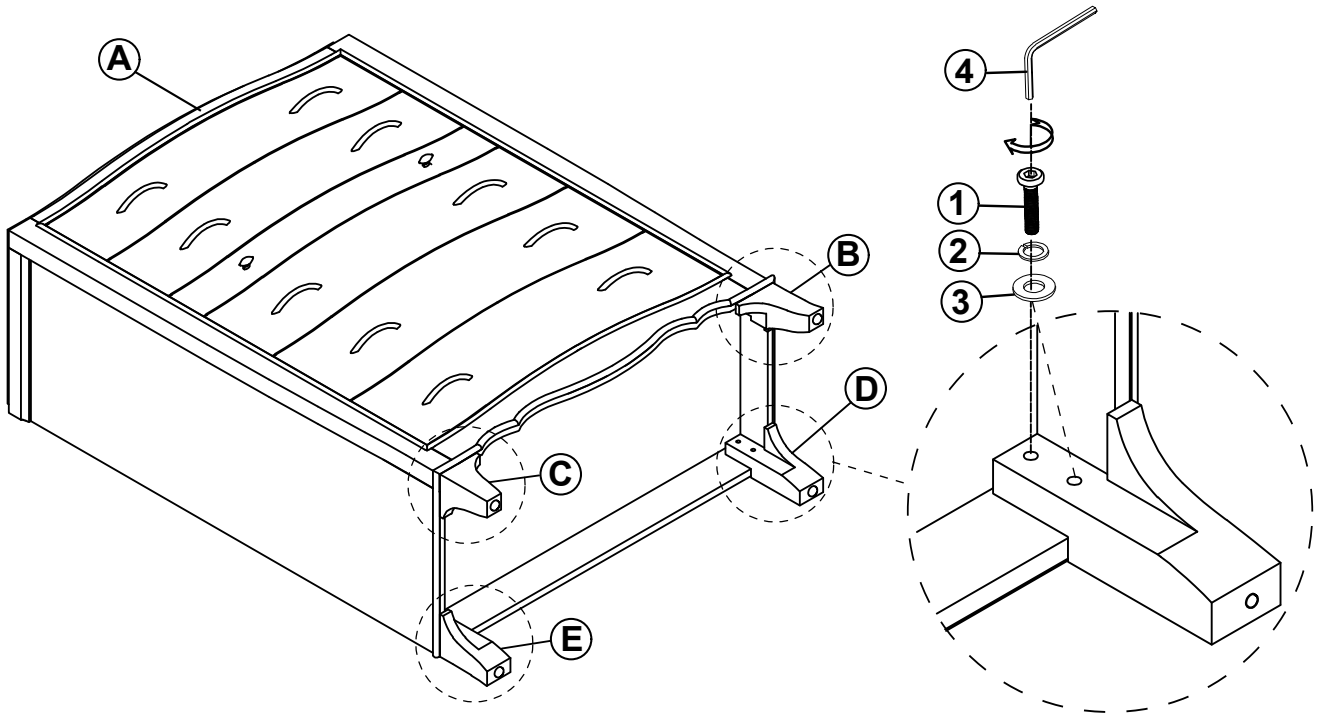

STEP 2
COMPLETE

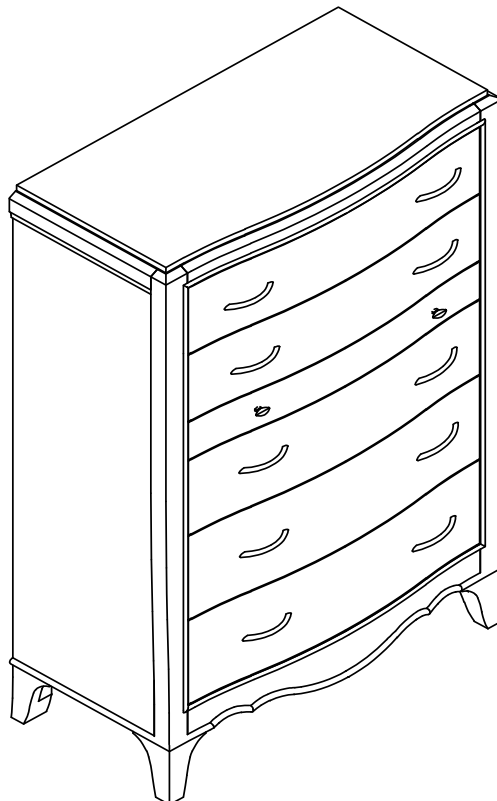

ANTI-TIPPING INSTALLATION INSTRUCTIONS

FURNITURE TIPPING RESTRAINT

WARNING

Injury may result from tipping furniture.

This restraint may protect against tipping furniture.

Do not allow children to climb on furniture.

This restraint is not a substitute for proper adult supervision.

Failure to detach this restraint before moving the furniture may result in injury and damage.

1. Attach one of the mounting brackets securely to the back edge of the unit, using the short screw.
2. Determine where the unit is to be placed, and mark the location on the wall for the other mounting bracket. The bracket on the wall needs to be approximately 2" below the bracket mounted to the edge of the unit.
3. Drill a hole in the wall. Insert the plastic wall anchor into the hole and if necessary, use a small block of wood and hammer to tap it in so that it's flush with the wall.
4. Attach the bracket over the plastic wall anchor using the long screw.
5. Place the unit against the wall, both brackets need to be facing each other.
6. Lace an end of the restraint strap through the hole in each bracket. Bring both ends together and rotate the thumb nut onto the threaded end until tight.
7. Ensure that the restraint strap is securely laced and locked.

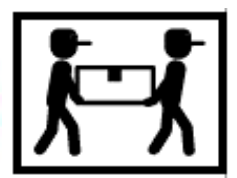
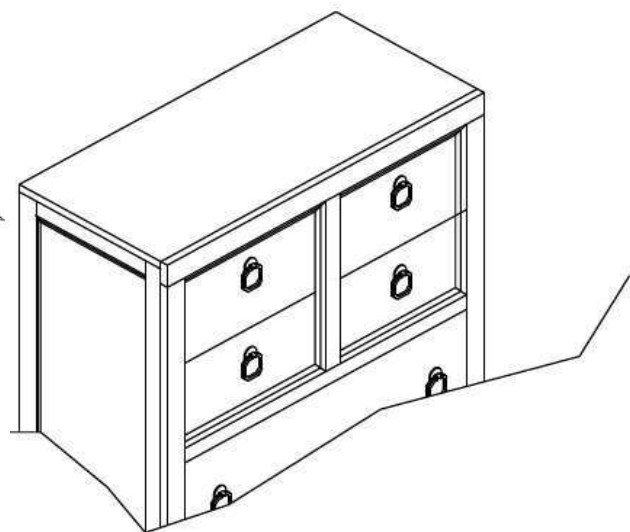
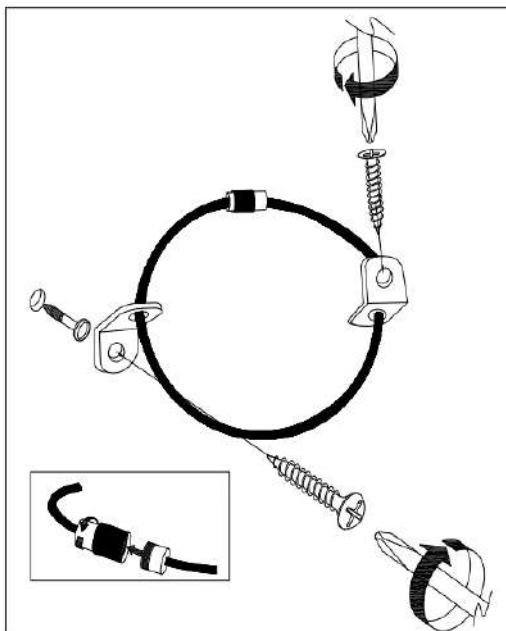

ITEM:225055



Inner Size of Drawer A : 33.00"W X 16.00"D X 5.25"H X 0.50"T
Inner Size of Drawer B : 33.00"W X 16.00"D X 3.00"H X 0.50"T
Inner Size of Drawer C : 33.00"W X 16.00"D X 6.25"H X 0.50"T
Inner Size of Drawer D : 33.00"W X 16.00"D X 6.25"H X 0.50"T

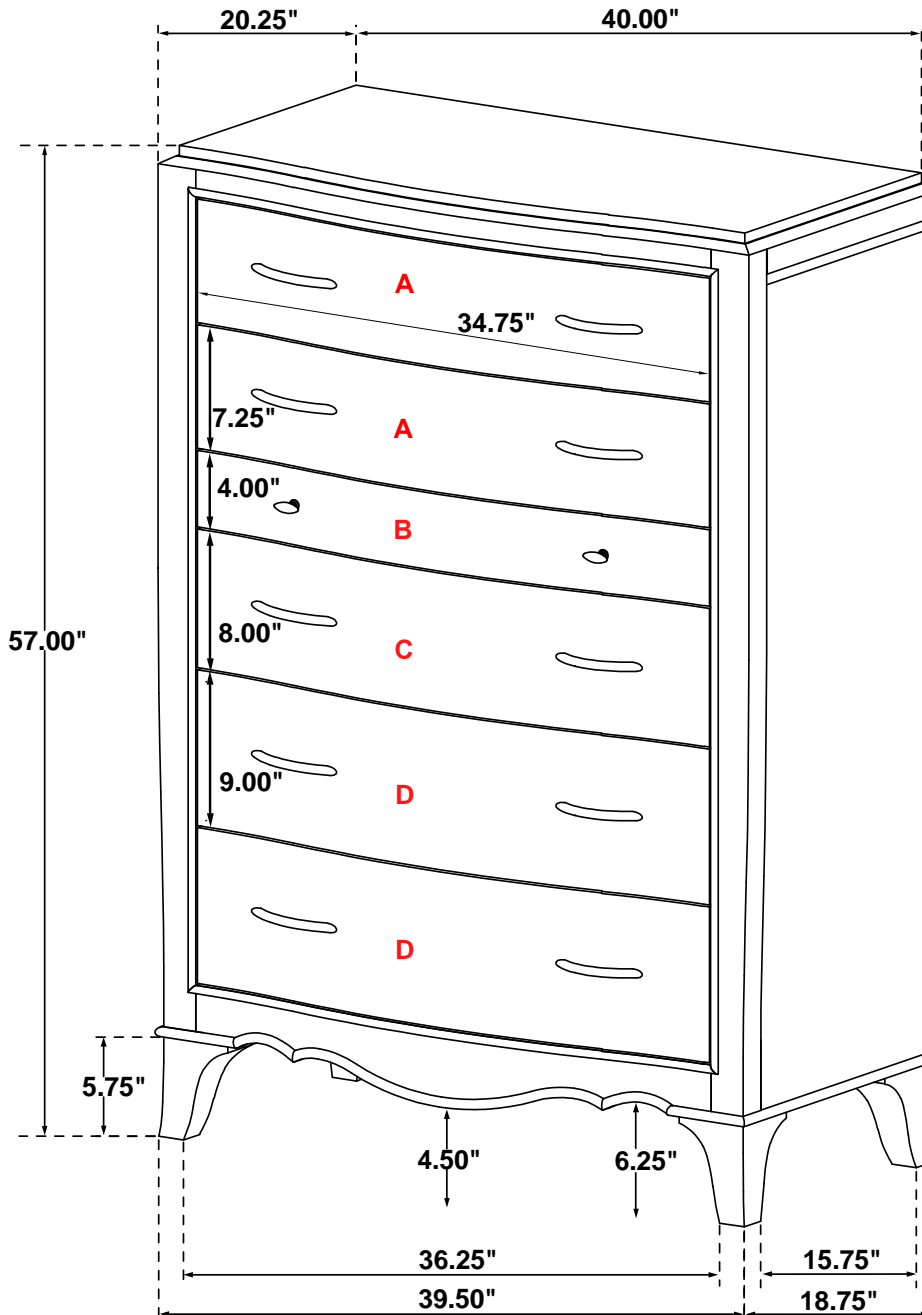

Note: Dimension tolerance $\pm 5\%$