

**ASSEMBLY INSTRUCTIONS**  
**COASTER FINE FURNITURE**

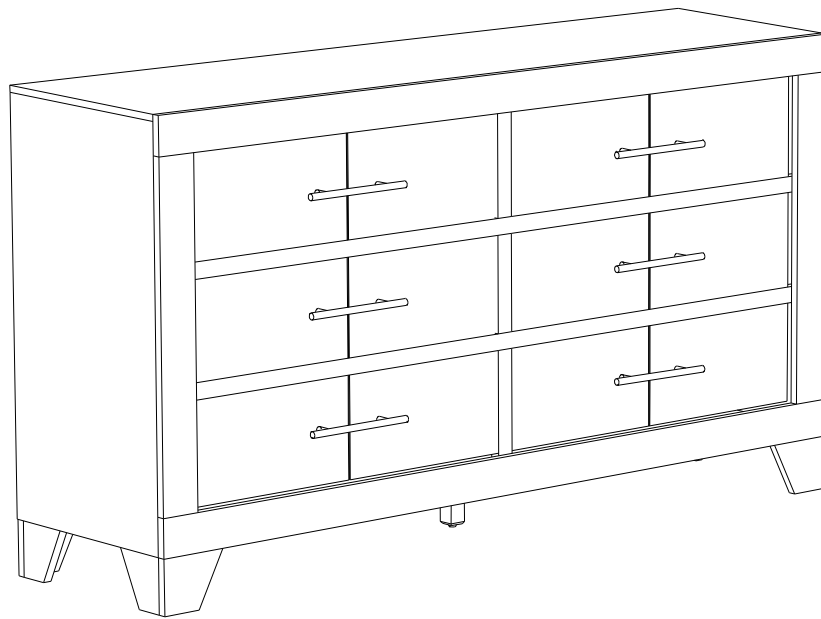

*Fine Furniture for every stage of life*

**225063**  
**Dresser**

ITEM: **225063**



## ASSEMBLY INSTRUCTIONS

### ASSEMBLY TIPS:

1. Remove hardware from box and sort by size.
2. Please check to see that all hardware and parts are present prior to start of assembly.
3. Please follow attached instructions in the same sequence as numbered to assure fast & easy assembly.



### WARNING!





1. Don't attempt to repair or modify parts that are broken or defective. Please contact the store immediately.
2. This product is for home use only and not intended for commercial establishments.





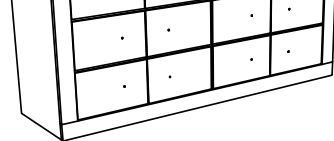

ASSEMBLY TIME

5 MINUTES

## PARTS IDENTIFICATION

A	DRESSER		1PC
B	LEG WITH LABEL "R"		2PCS
C	LEG WITH LABEL "L"		2PCS
D	CENTER SUPPORT LEG WITH LEVELER		1PC

## HARDWARE IDENTIFICATION

1	BOLT (M6 x 35mm - BLK)		4PCS
2	LOCK WASHER (1/4" - BLK)		4PCS
3	FLAT WASHER (1/4"ID x 19mm - BLK)		4PCS
4	WOOD DOWEL (8 x 20mm )		4PCS
5	ALLEN WRENCH (M4 x 60mm - BLK)		1PC

### NOTE:

Phillips head screw driver is required in the assembly process; however, manufacturer does not provide this item.

ITEM: **225063**

**ASSEMBLY INSTRUCTIONS**



**STEP 1**

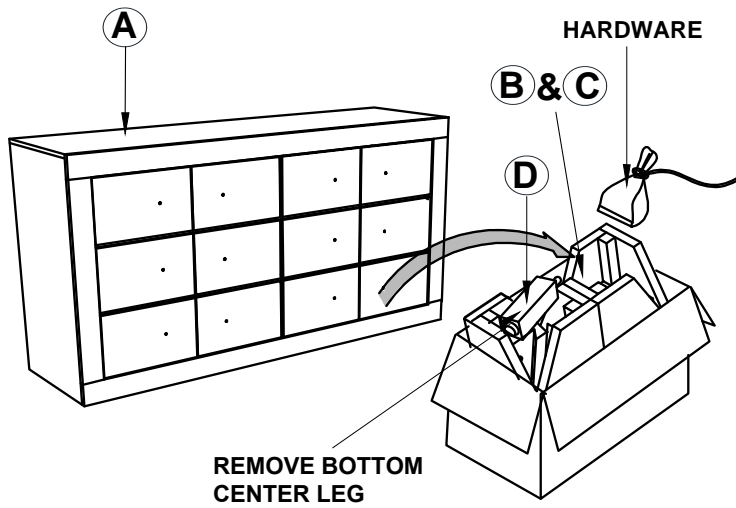

**STEP 2**

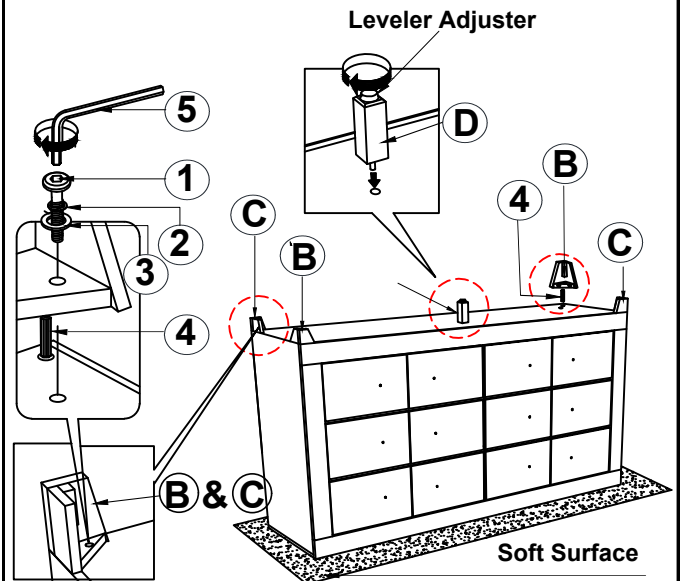

Bottom View

**STEP 3**

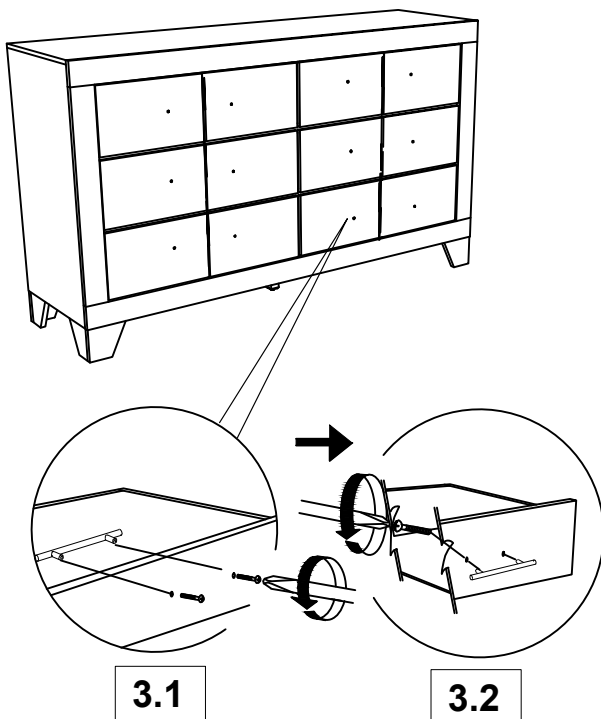

**STEP 4**

**COMPLETE**

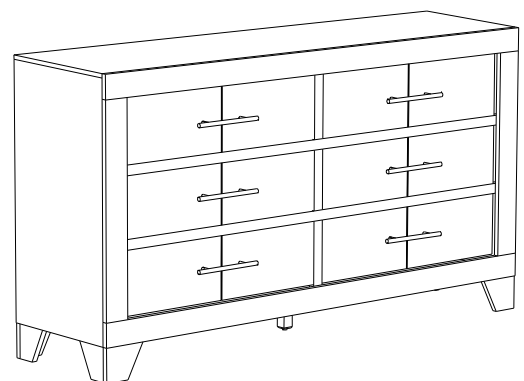

ITEM:225063



Inner Size of Drawer : 23.25"W x 11.25"D x 5.25"H x 0.25"T

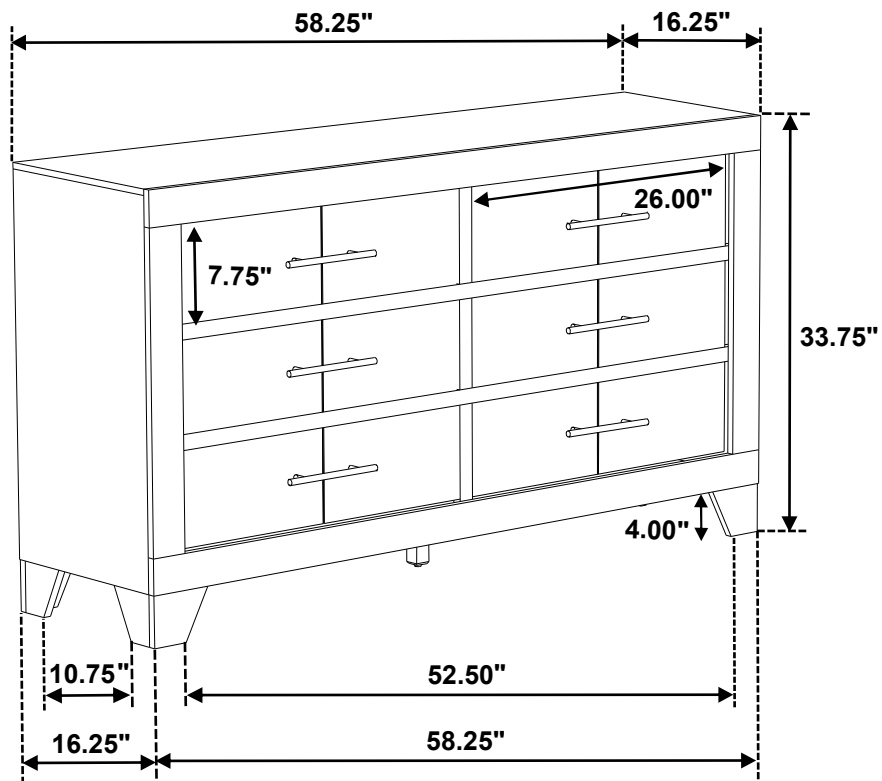

Note : Dimension tolerance  $\pm 5\%$

**ASSEMBLY INSTRUCTIONS**  
**COASTER FINE FURNITURE**



*Fine Furniture for every stage of life*

**225063**  
**Dresser**

ITEM: **225063**



## ASSEMBLY INSTRUCTIONS

### ASSEMBLY TIPS:

1. Remove hardware from box and sort by size.
2. Please check to see that all hardware and parts are present prior to start of assembly.
3. Please follow attached instructions in the same sequence as numbered to assure fast & easy assembly.



### WARNING!

1. Don't attempt to repair or modify parts that are broken or defective. Please contact the store immediately.
2. This product is for home use only and not intended for commercial establishments.



ASSEMBLY TIME

5 MINUTES

## PARTS IDENTIFICATION

A	DRESSER		1PC
B	LEG WITH LABEL "R"		2PCS
C	LEG WITH LABEL "L"		2PCS
D	CENTER SUPPORT LEG WITH LEVELER		1PC

## HARDWARE IDENTIFICATION

1	BOLT (M6 x 35mm - BLK)		4PCS
2	LOCK WASHER (1/4" - BLK)		4PCS
3	FLAT WASHER (1/4"ID x 19mm - BLK)		4PCS
4	WOOD DOWEL (8 x 20mm )		4PCS
5	ALLEN WRENCH (M4 x 60mm - BLK)		1PC

### NOTE:

Phillips head screw driver is required in the assembly process; however, manufacturer does not provide this item.

ITEM: **225063**

**ASSEMBLY INSTRUCTIONS**



**STEP 1**

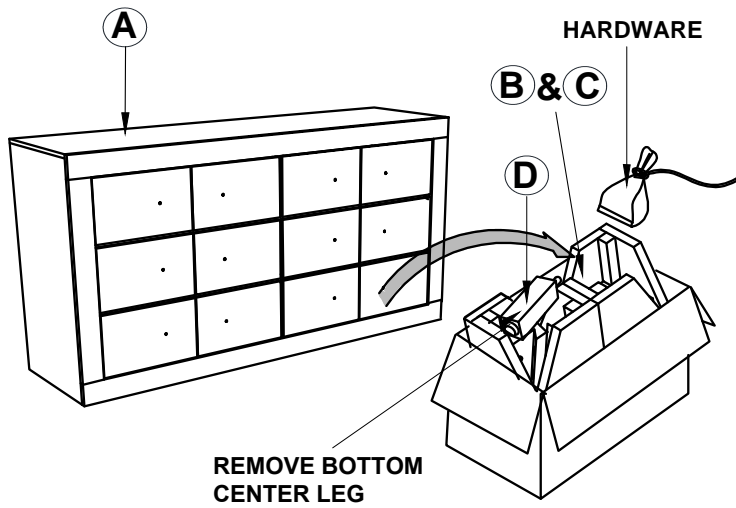

**STEP 2**

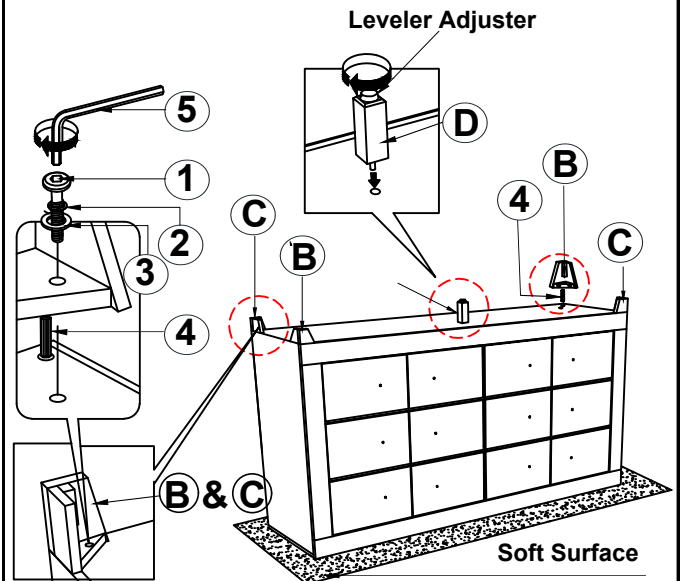

Bottom View

**STEP 3**

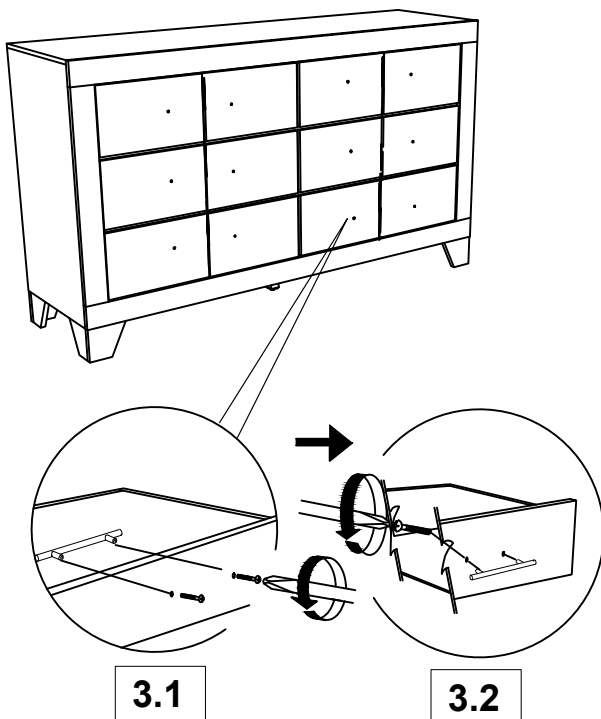

**STEP 4**

**COMPLETE**

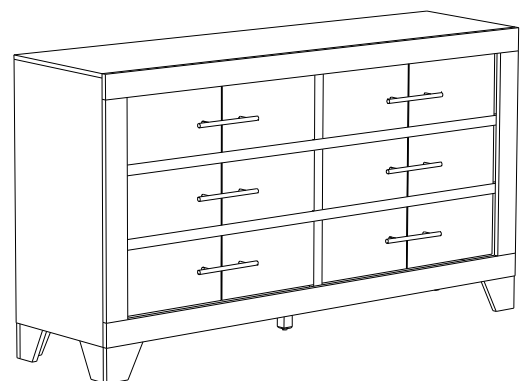

ITEM:225063



Inner Size of Drawer : 23.25"W x 11.25"D x 5.25"H x 0.25"T

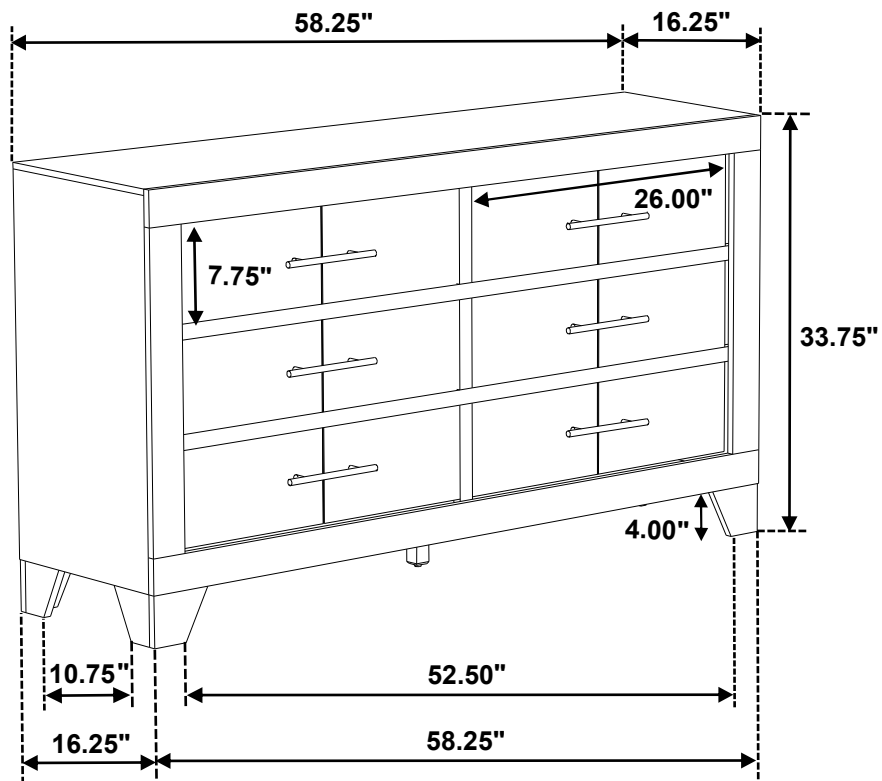

Note : Dimension tolerance  $\pm 5\%$

**ASSEMBLY INSTRUCTIONS**  
**COASTER FINE FURNITURE**



*Fine Furniture for every stage of life*

**225064**  
**Mirror**

ITEM: **225064**



## ASSEMBLY INSTRUCTIONS

### ASSEMBLY TIPS:

1. Remove hardware from box and sort by size.
2. Please check to see that all hardware and parts are present prior to start of assembly.
3. Please follow attached instructions in the same sequence as numbered to assure fast & easy assembly.



### WARNING!

1. Don't attempt to repair or modify parts that are broken or defective. Please contact the store immediately.
2. This product is for home use only and not intended for commercial establishments.



ASSEMBLY TIME

10 MINUTES

## PARTS IDENTIFICATION

A MIRROR

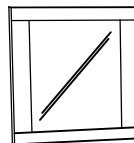

1PC

B DRESSER FROM  
BOX ITEM #225063

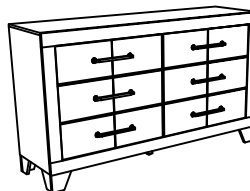

1PC

C MIRROR SUPPORT  
(PACK WITH MIRROR)



2PCS

## HARDWARE IDENTIFICATION

1 FLAT HEAD SCREW  
(M4 x 32mm - RBW)



10PCS

### NOTE:

Phillips head screw driver is required in the assembly process; however, manufacturer does not provide this item.

ITEM: **225064**

# ASSEMBLY INSTRUCTIONS

## STEP 1

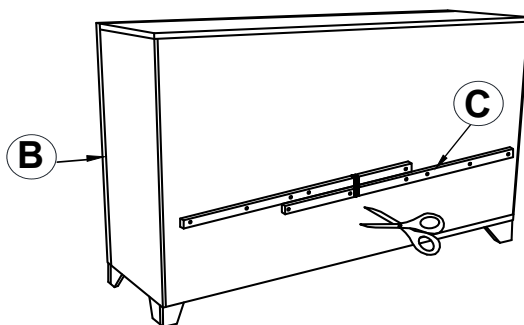

**\*\*BACK VIEW\*\***

## STEP 2

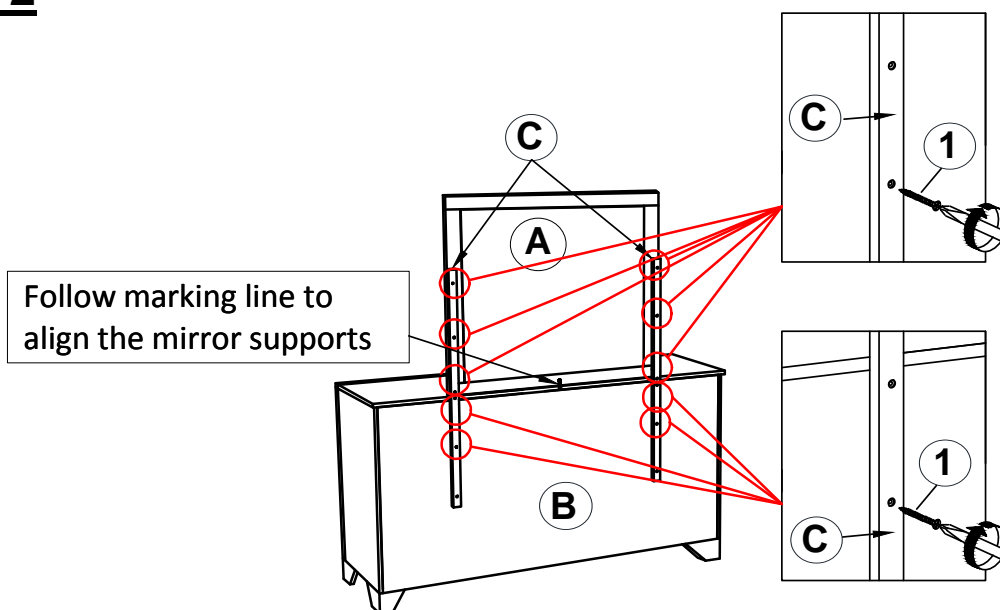

## STEP 3 COMPLETE



ITEM:225064

**COASTER**  
FINE FURNITURE

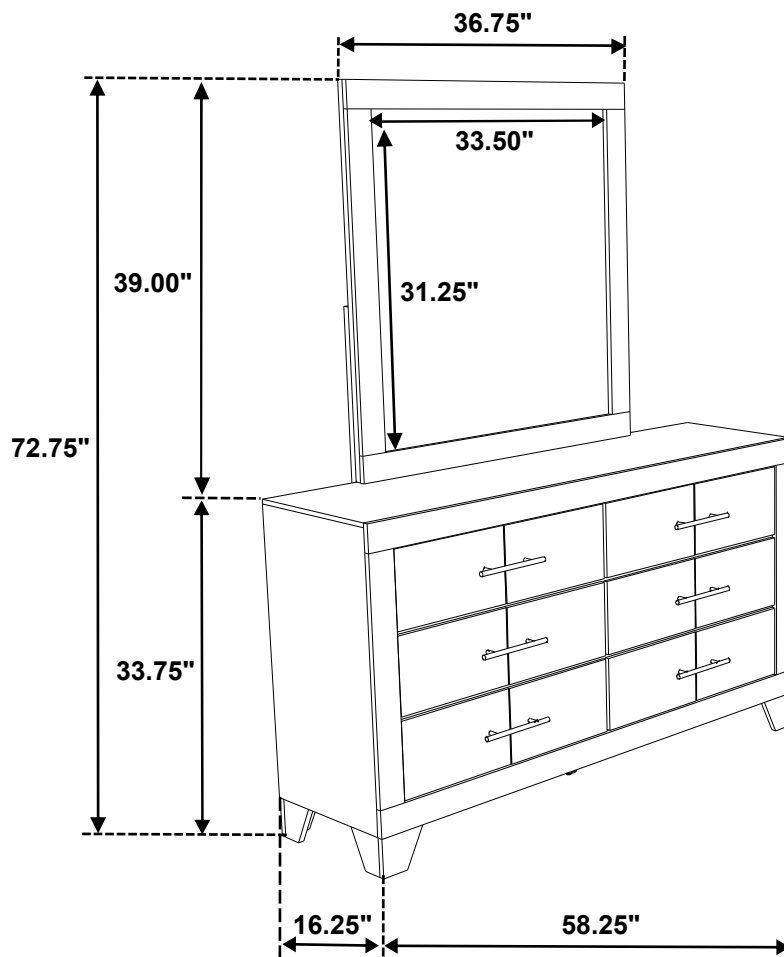

Note : Dimension tolerance  $\pm 5\%$

**ASSEMBLY INSTRUCTIONS**  
**COASTER FINE FURNITURE**



*Fine Furniture for every stage of life*

**225064**  
**Mirror**

ITEM: **225064**



## ASSEMBLY INSTRUCTIONS

### ASSEMBLY TIPS:

1. Remove hardware from box and sort by size.
2. Please check to see that all hardware and parts are present prior to start of assembly.
3. Please follow attached instructions in the same sequence as numbered to assure fast & easy assembly.



### WARNING!

1. Don't attempt to repair or modify parts that are broken or defective. Please contact the store immediately.
2. This product is for home use only and not intended for commercial establishments.



ASSEMBLY TIME

10 MINUTES

## PARTS IDENTIFICATION

A MIRROR

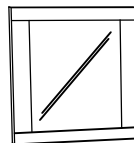

1PC

B DRESSER FROM  
BOX ITEM #225063

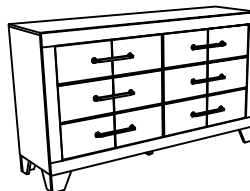

1PC

C MIRROR SUPPORT  
(PACK WITH MIRROR)



2PCS

## HARDWARE IDENTIFICATION

1 FLAT HEAD SCREW  
(M4 x 32mm - RBW)



10PCS

### NOTE:

Phillips head screw driver is required in the assembly process; however, manufacturer does not provide this item.

ITEM: **225064**

# ASSEMBLY INSTRUCTIONS

## STEP 1

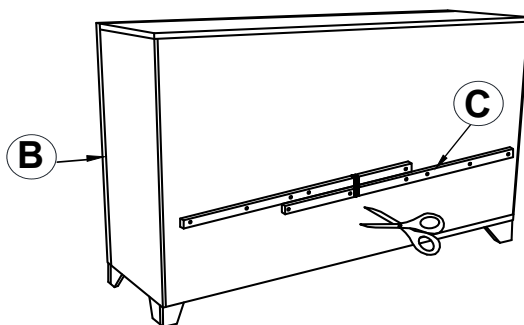

**\*\*BACK VIEW\*\***

## STEP 2

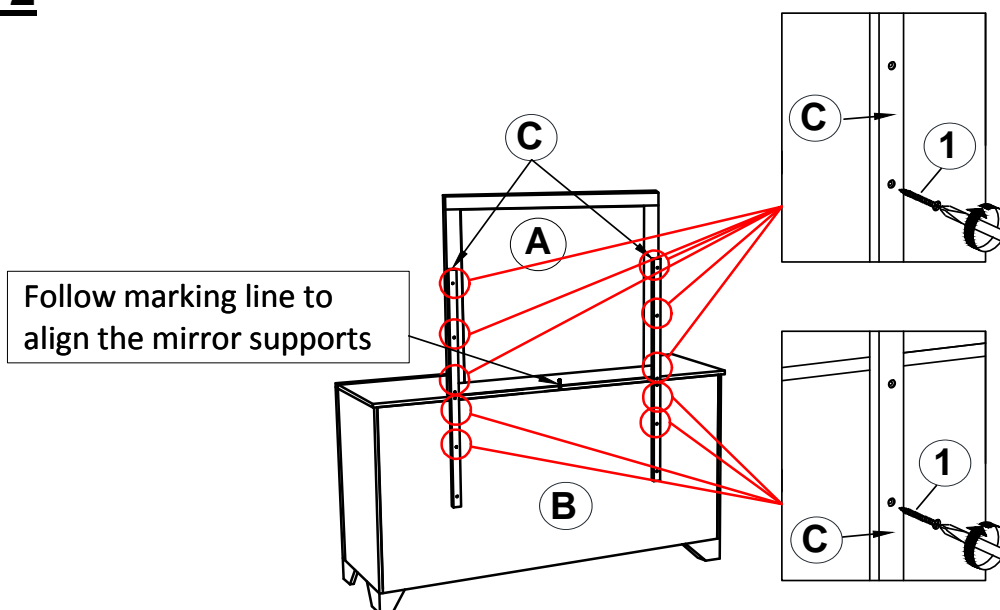

Follow marking line to align the mirror supports

## STEP 3 **COMPLETE**



ITEM:225064

**COASTER**  
FINE FURNITURE

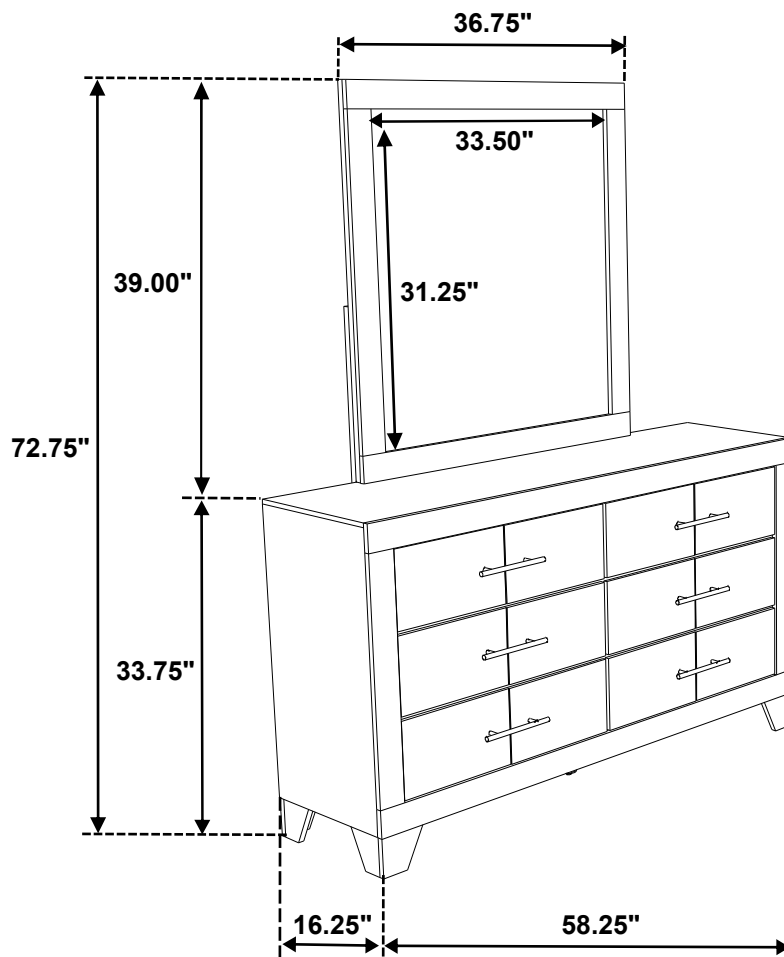

Note : Dimension tolerance  $\pm 5\%$