

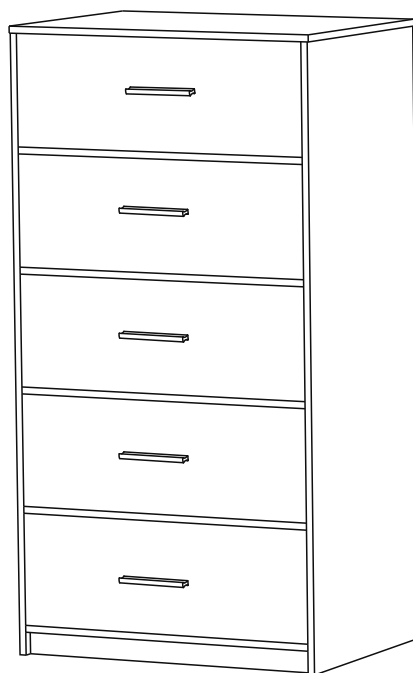

MODEL RTA-DSR05

ASSEMBLY INSTRUCTIONS

(REV.3-ALL-8962-0625)



Thank you for purchasing our product!

 Visit our Website
www.technihome.com



 View Assembly Video
Technihome.com/pages/assembly-videos

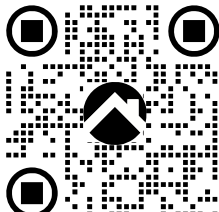





 Contact Us
support@rtaproducts.com

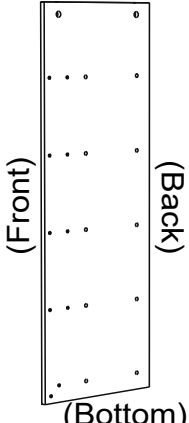
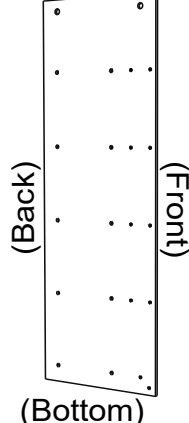
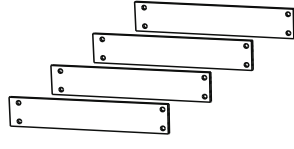
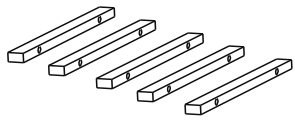
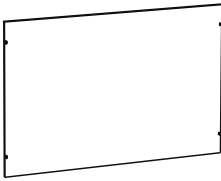
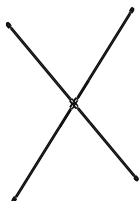
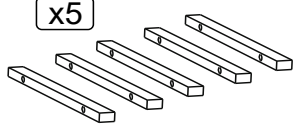
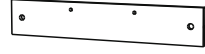
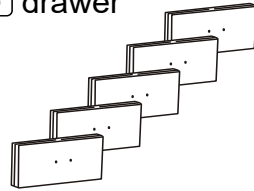
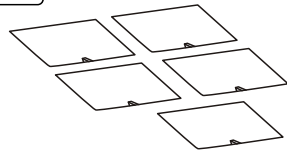

MAIN PARTS LIST

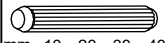
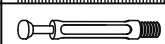
| | | | |
|---|--|--|--|
| <p>A Left side panel (Top) (Front) (Back) (Bottom)</p>  | <p>B Right side panel (Top) (Back) (Front) (Bottom)</p>  | <p>C Back support x4</p>  | <p>D Left support x5</p>  |
| <p>H Top panel</p>  | <p>I Cross bars (joined)</p>  | <p>E Right support x5</p>  | <p>F Bottom support</p>  |
| | | <p>J Foldable fabric drawer x5</p>  | <p>K Drawer bottom x5</p>  |

HARDWARE LIST

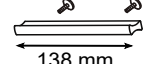
| PART | QTY | SIZE / DESCRIPTION | ITEM |
|------|--------|--|---|
| 1 | 2 | Ø8x40mm |  mm 10 20 30 40 50 60 |
| 2 | 24 | M6x40 Bolt (Minifix) |  mm 10 20 30 40 50 60 |
| 3 | 24 | Ø15x10 Cam lock (minifix) |  mm 10 20 30 40 50 60 |
| 4 | 4 | M4x25mm |  mm 10 20 30 40 50 60 |
| 5 | 20 | M6x25 |  mm 10 20 30 40 50 60 |
| 6 | 5 Sets | 138mm Handle (x5) + M4x10 screws (x10) |  138 mm |



TOOL INCLUDED

| | |
|--|---|
| Combination Allen Key (Hex + Phillips) |  |
|--|---|

ANTI TIP-OVER HARDWARE

| PART | QTY | SIZE / DESCRIPTION | ITEM |
|------|-----|-----------------------|---|
| 8 | 2 | 200x25mm Safety strip |  200 mm |
| 9 | 2 | M4x30mm Wall Anchor |  mm 10 20 30 40 50 60 |
| 10 | 2 | M4x60mm |  mm 10 20 30 40 50 60 |

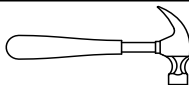
TOOLS REQUIRED BUT NOT INCLUDED

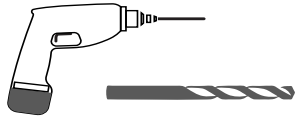
| | |
|--------------------------------|---|
| Hammer |  |
| Pencil |  |
| Power drill with M4 drill bits |  |



For Support, Assembly Questions & Replacement Parts Within the 48 Contiguous United States:

Please email us at: support@rtaproducts.com



Replacement Parts for International Customers & **AK-HI-PR** orders:

RTA Products will replace the part free of charge, while **the customer is responsible for shipping costs plus any International local taxes or duties.**

ASSEMBLY STEPS

WE RECOMMEND TO PLACE THE PIECES OVER BLANKETS OR TABLECLOTHS TO PROTECT THEIR FINISH DURING ASSEMBLY.

STEP 1

Hardware

Hardware

5



20
Pcs

M6x25

Tools (included)

M6



FIRST: Attach D to A with #5.

(Top)

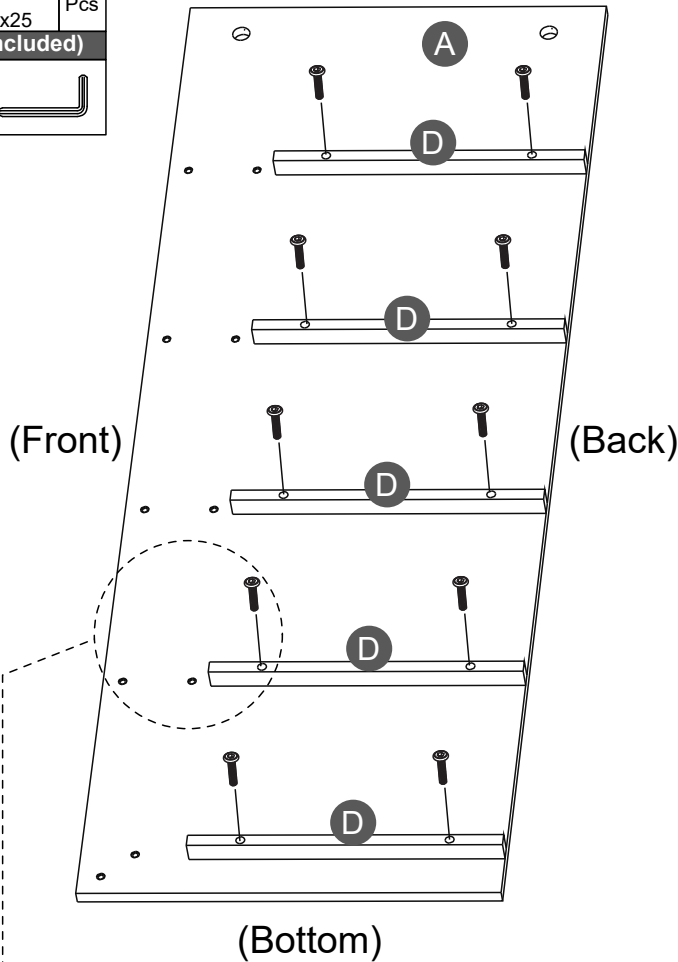

⚠ PAY ATTENTION!

D goes on A,
E goes on B.

THEN: Attach E to B with #5.

(Top)

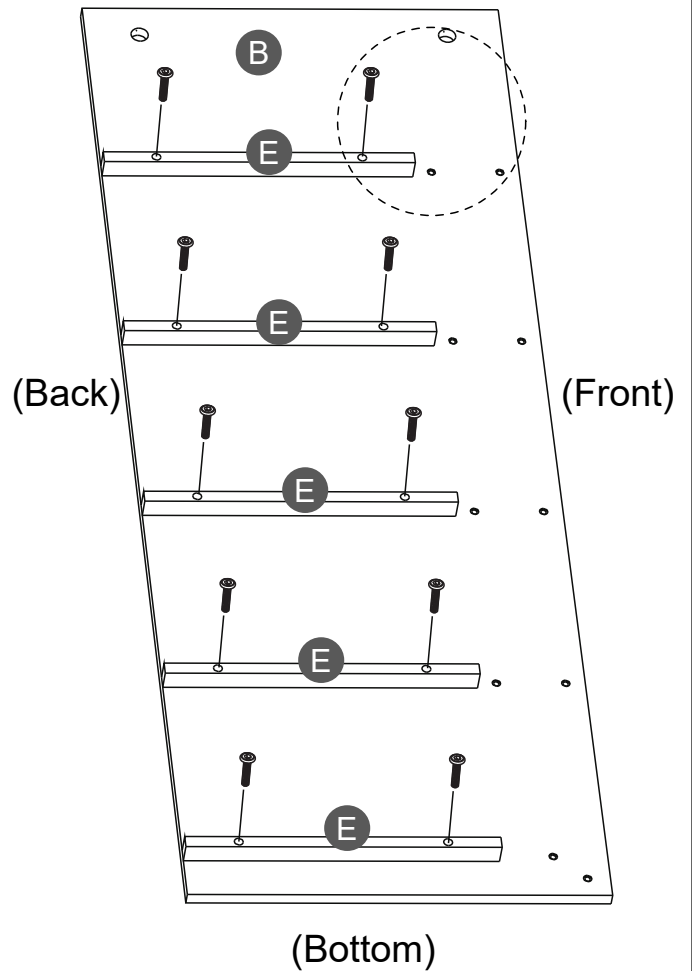

ASSEMBLY STEPS

STEP 2

Hardware

2



20
Pcs

M6x40

Tools (included)

M6



Attach #2 to A and B.

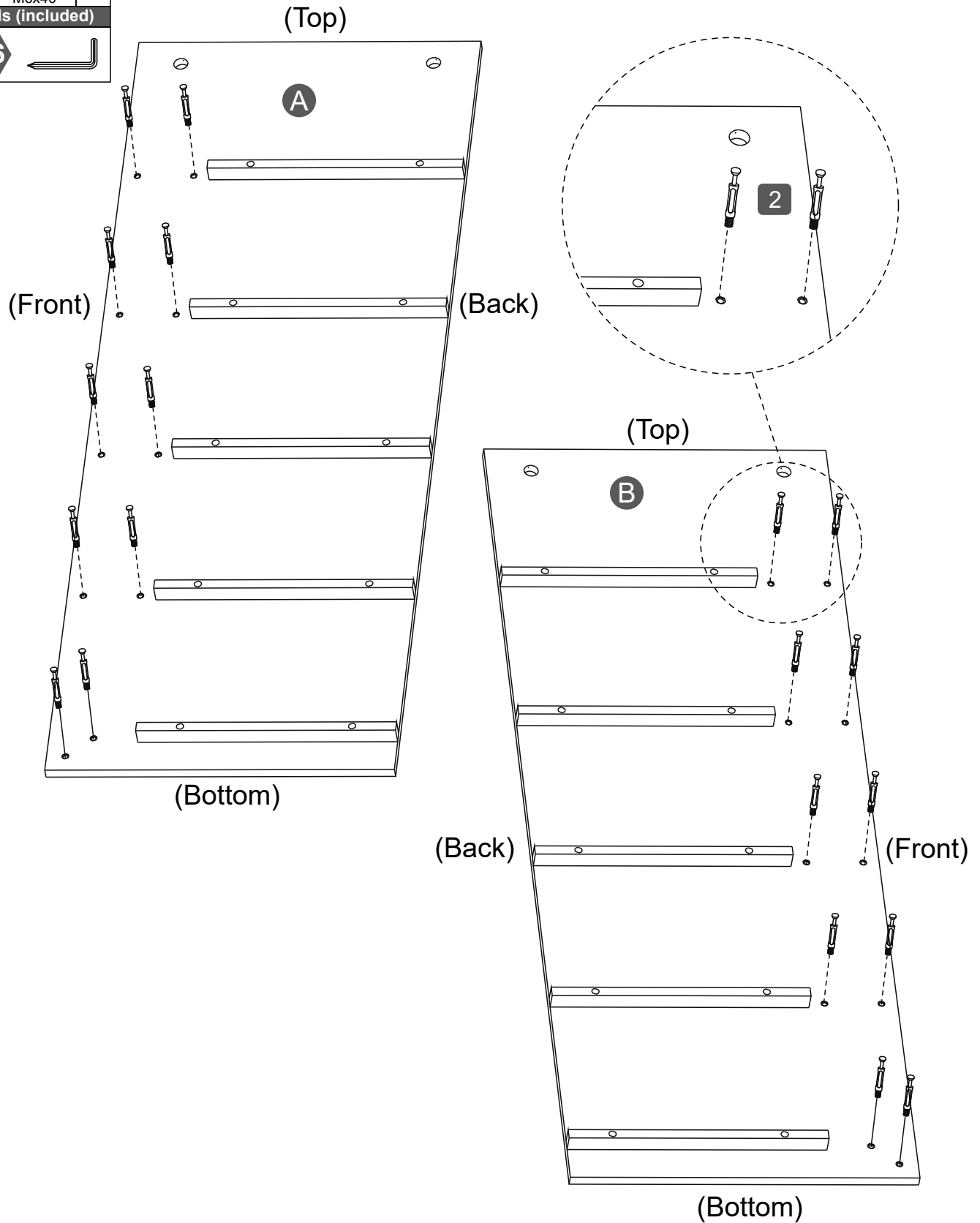

ASSEMBLY STEPS

STEP 3

Hardware

1  2 Pcs
Ø8x40mm

Tools (included)

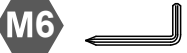

Attach F to G with #1.

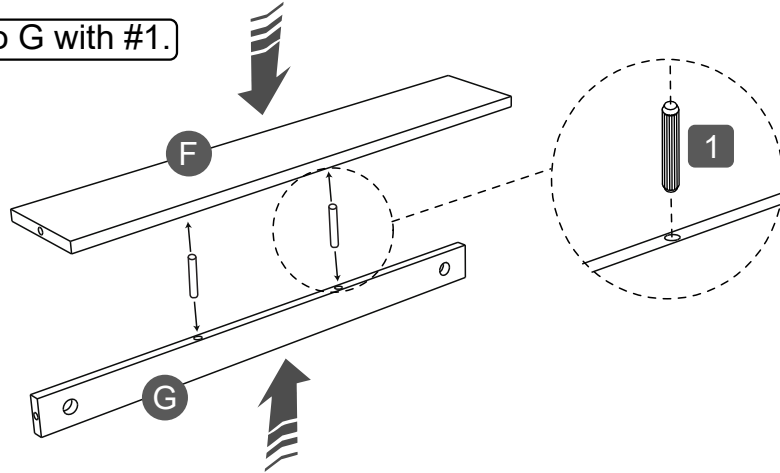

STEP 4

This step requires of 2 people 

Hardware

3  10 Pcs
Ø15x10mm

Tools (included)



FIRST: Join F+G to the bolts on the bottom of B, and lock them by inserting and turning the cam locks #3.

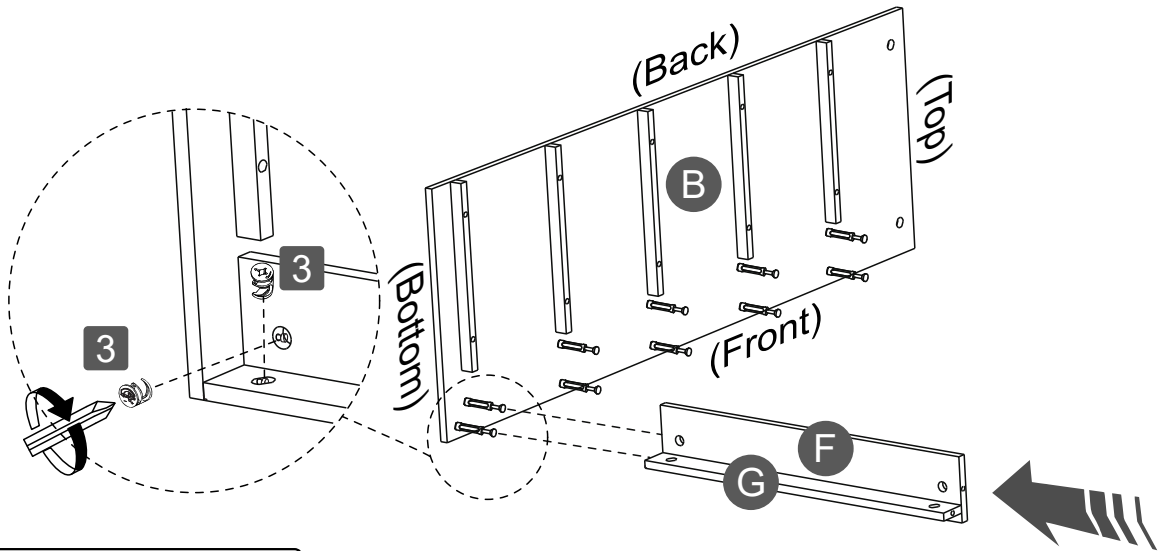

THEN: Do the same with panels C for the rest of the bolts.

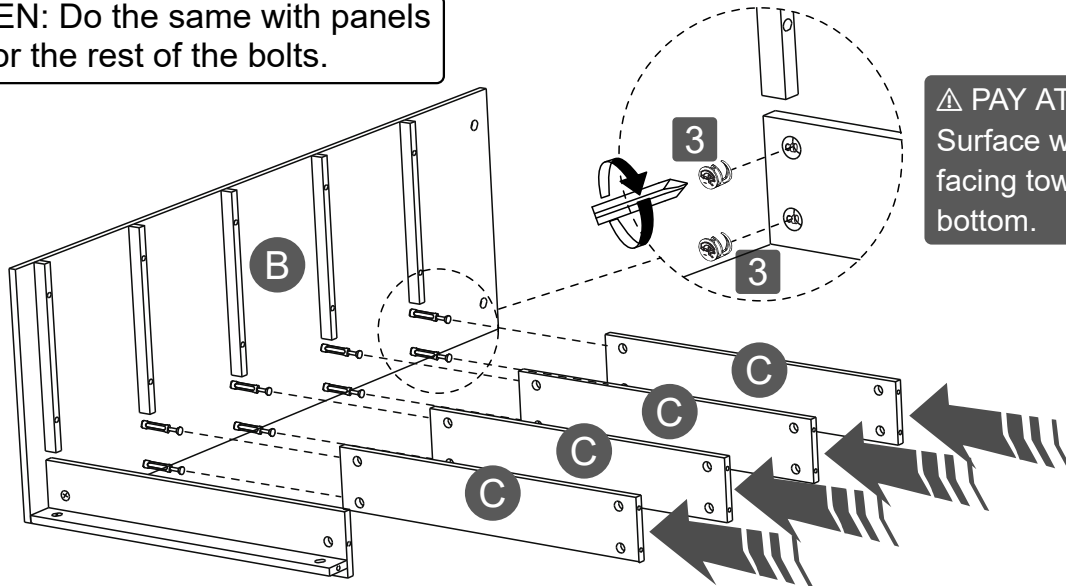

⚠ PAY ATTENTION!
Surface with big holes facing towards the bottom.

ASSEMBLY STEPS

STEP 5

This step requires of 2 people

Hardware

3  10 Pcs
Ø15x10mm

Tools (included)

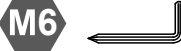

Assemble A to C, F and G with #3 the same way you did on step 4.

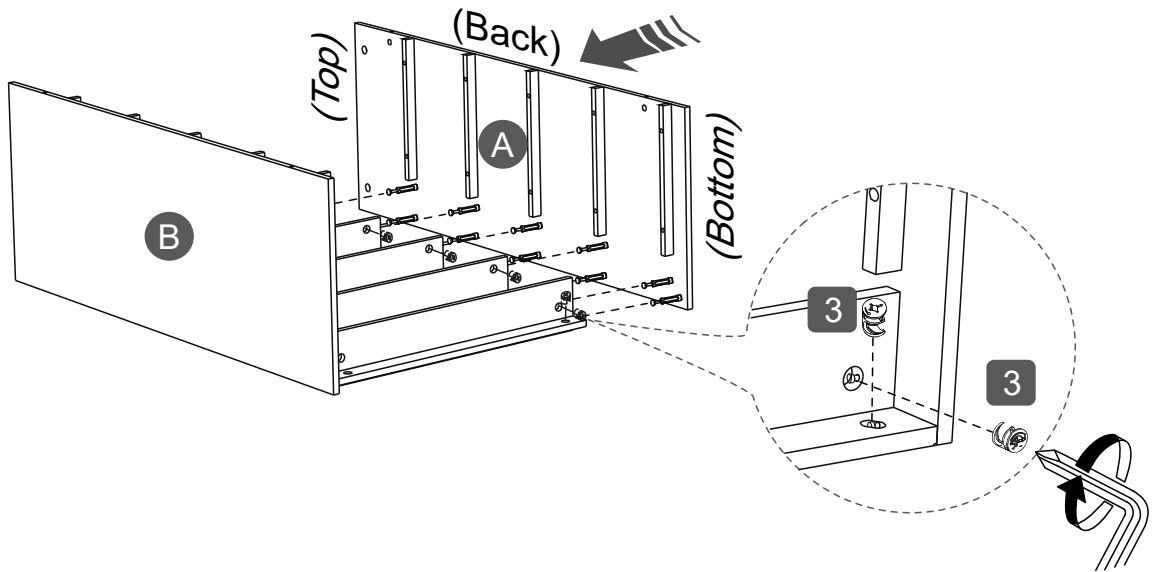

STEP 6

This step requires of 2 people

Hardware

2  4 Pcs
Ø6x40mm

3  4 Pcs
Ø15x10mm

Tools (included)

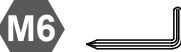

FIRST: Attach #2 to H.

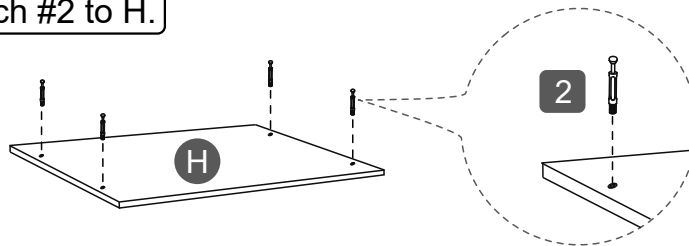

THEN: Assemble H to A and B with #3.

LAST: Flip the unit upright.

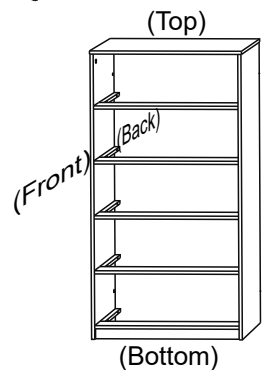
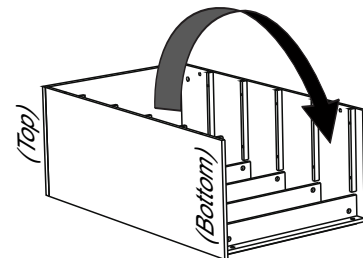
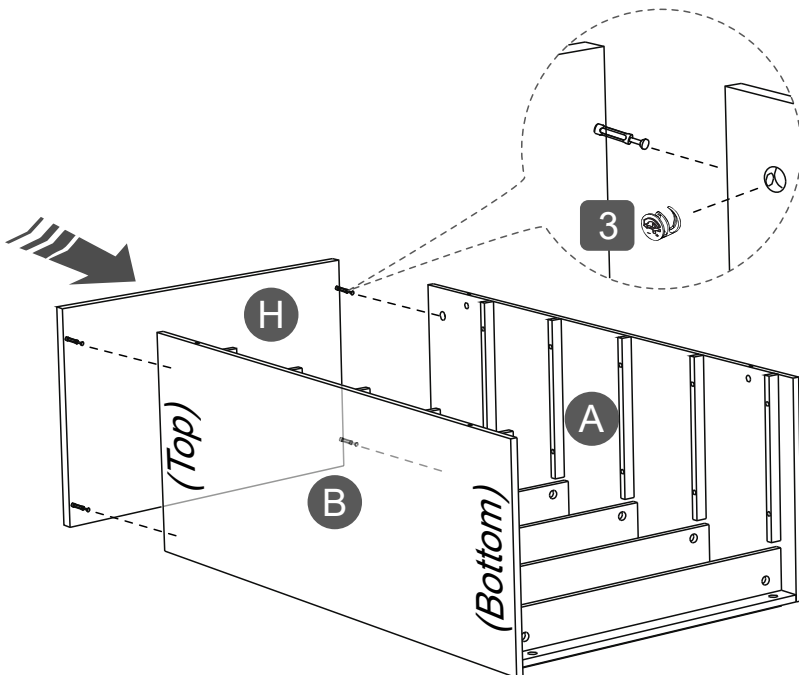

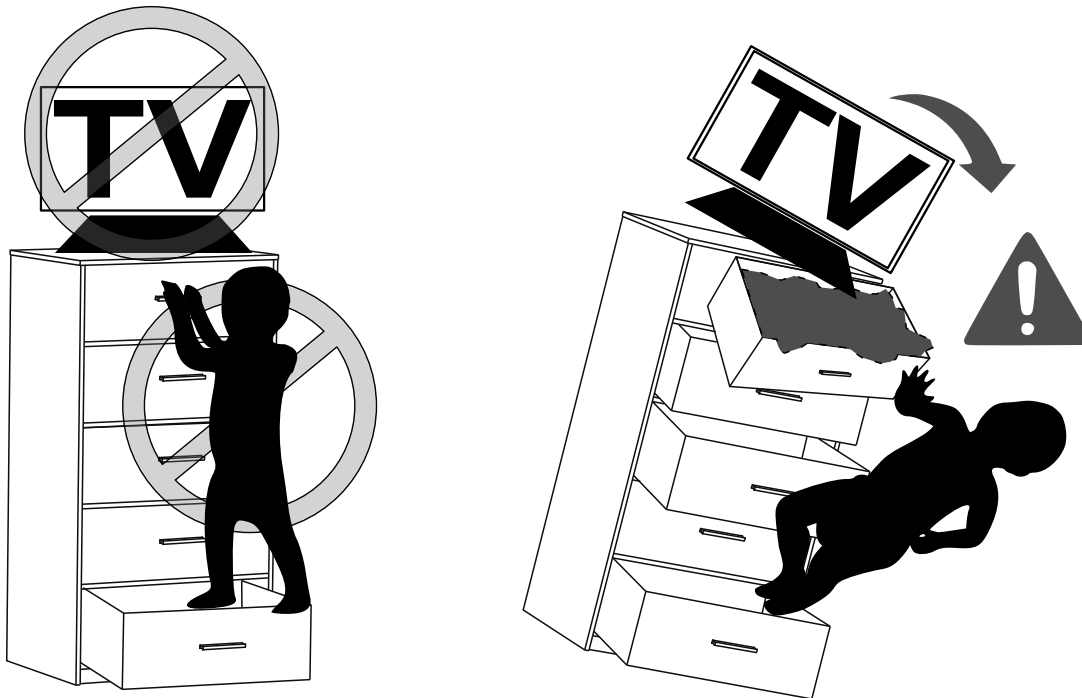
TIP OVER WARNING!**VERY IMPORTANT - PLEASE READ!**

Children have died from furniture tip over. To reduce the risk of tip over:

- Install the anti tipping device that is included with this product.
- Follow the instructions on the next page of this manual for installing the anti tipping device and have the unit secure to a wall.
- NEVER allow children to stand, climb, or hang on drawers, doors or shelves.
- Place heaviest items in the lowest drawers.
- NEVER put a TV on this furniture.





Please continue with the rest of the assembly instructions on the next page. Thank you.

ASSEMBLY STEPS

STEP 8

This step requires of  2 people

Hardware

| | | |
|----|---|-------|
| 4 |  | 4 Pcs |
| 8 |  | 2 Pcs |
| 9 |  | 2 Pcs |
| 10 |  | 2 Pcs |

Tools (included)

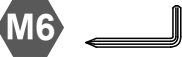

Tools (Not included)

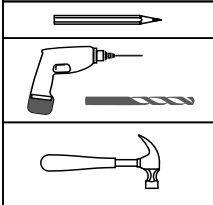

DO NOT SKIP THE INSTALLATION OF THE ANTI TIPPING DEVICE!

FIRST: On the back of the unit, attach the cross bars I to the side panels A and B with screws #4, with the Safety Strips #8 also installed AT THE TOP AND UNDER the cross bars.

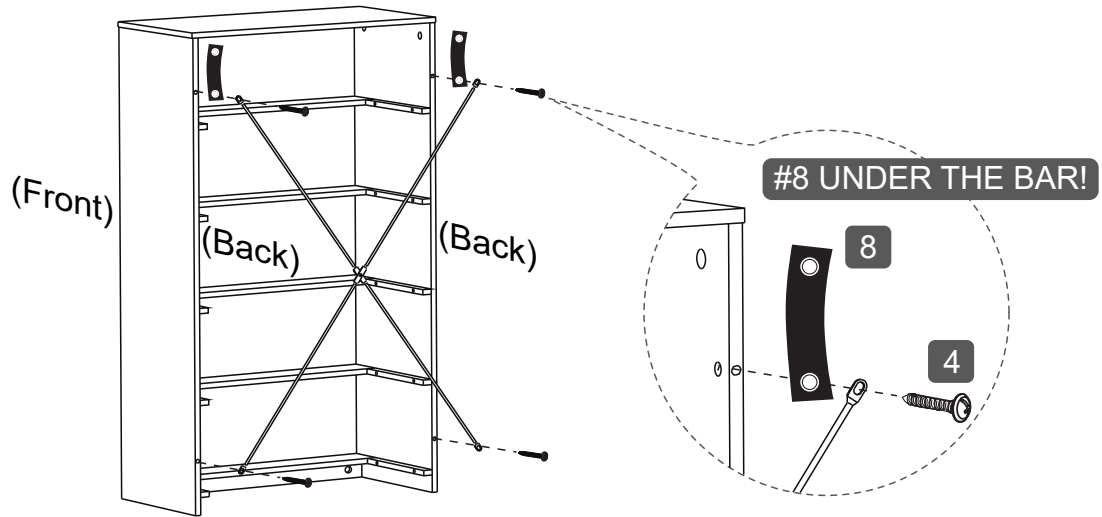

THEN: Put the unit against the wall where it will stay, and use a driller (not included) to make 2 holes on the wall and insert the anchor #9 for the 2 safety strips.

LAST: Secure the safety strips to the anchors with screws #10.

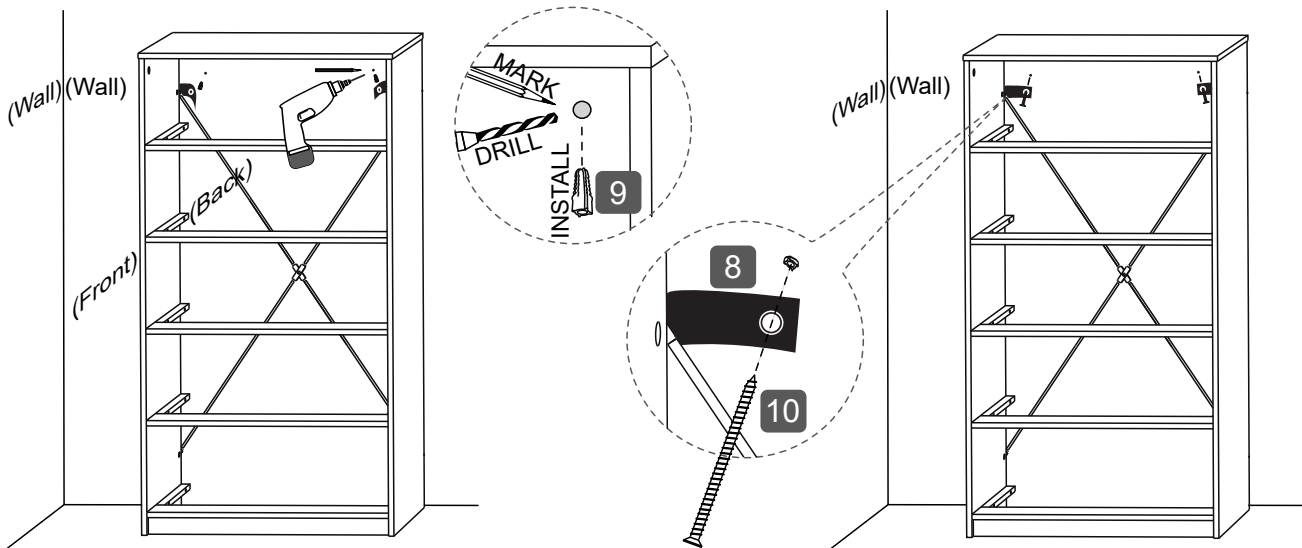

ASSEMBLY STEPS

STEP 8

Hardware

6

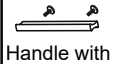

Handle with
2 screws

5
Sets

Tools (Included)

M6



FIRST: Unfold the drawers J and place the bottoms K into each of them.

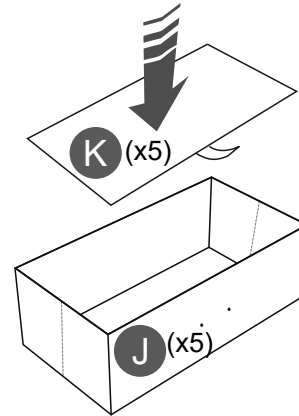
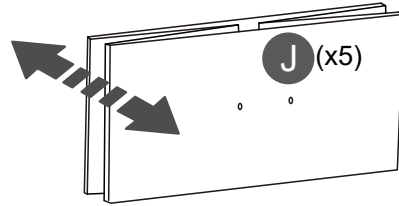

THEN: Attach the handles #6 to the drawers with their own screws.

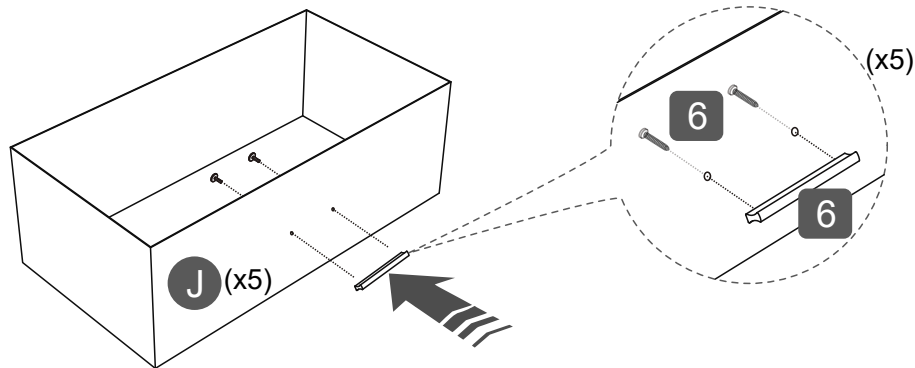

FINALLY: Insert the drawers in to the unit.

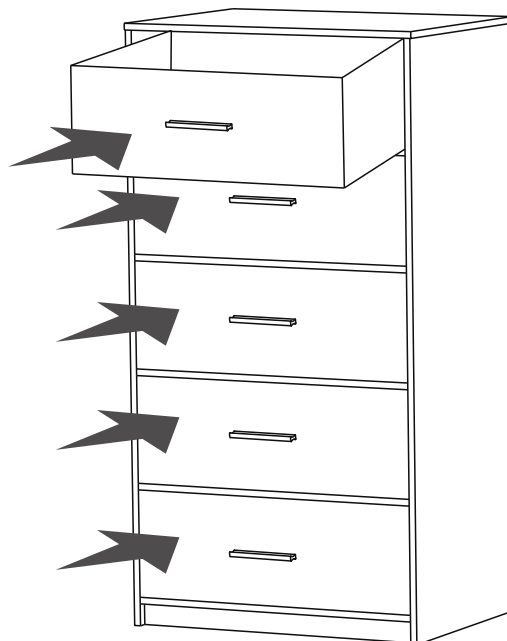

WARNINGS

Not paying attention to the following warnings could result in injuries.

Children have died from furniture tip over. To reduce the risk of tip over:

- Make sure you have installed the anti tipping device that has been included with this product.
- NEVER allow children to stand, climb, or hang on drawers, doors or shelves.
- Place heaviest items in the lowest drawers.
- NEVER put a TV on this furniture.
- Every 4 months, inspect the anti tipping device to make sure it is still secured to both the unit and the wall.
- Do not exceed the indicated weight limits.

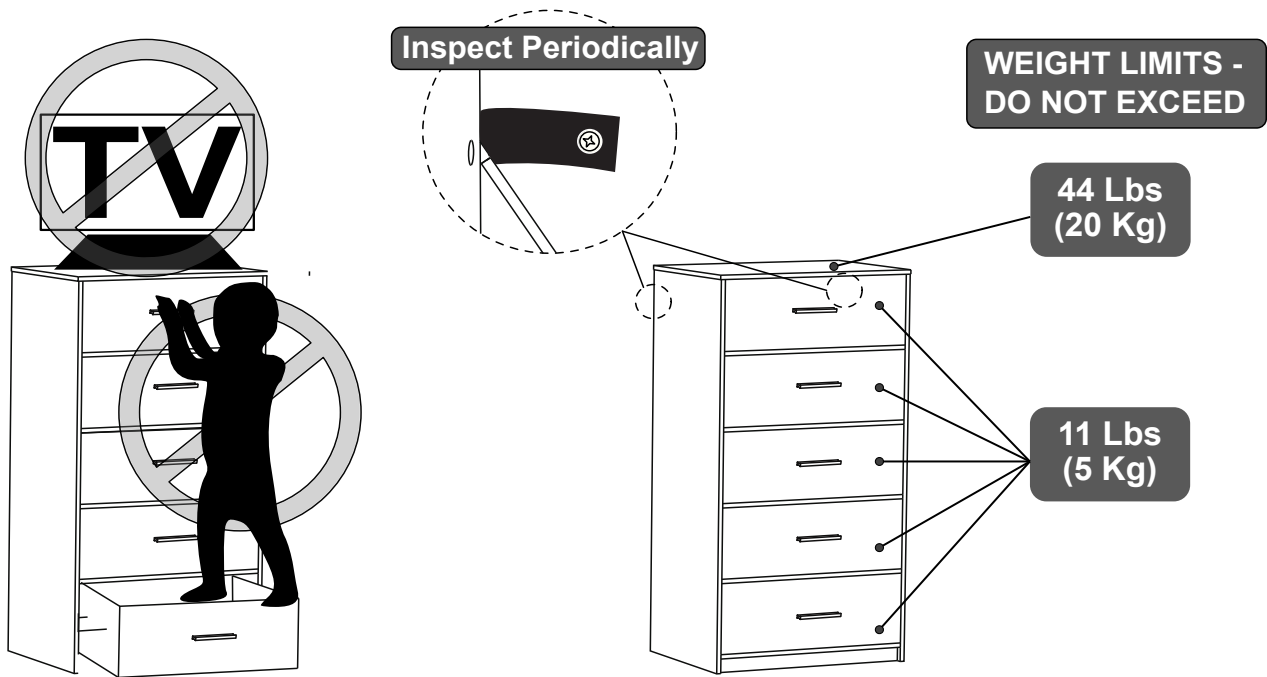

CARE AND MAINTENANCE

Clean with a cloth lightly damped in a solution of mild soap and water.

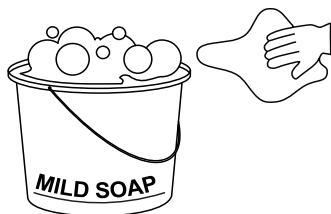

Do not use solvents or abrasive materials.



Do not expose to direct sunlight or extreme environmental conditions.

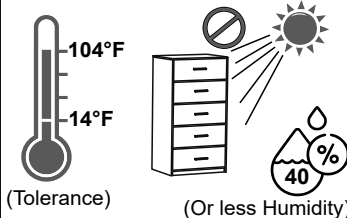

Inspect and re-tighten loose screws on the unit every 4 months.

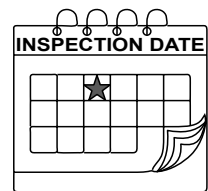

LIMITED WARRANTY



For details, please visit our website:
TechniHome.com

To file a claim or request information, please email to:
warranty@rtaproducts.com

