

INSTRUCCIONES DE ARMADO / ASSEMBLY INSTRUCTIONS COMODA ALTA HUNA / HUNA TALL DRESSER

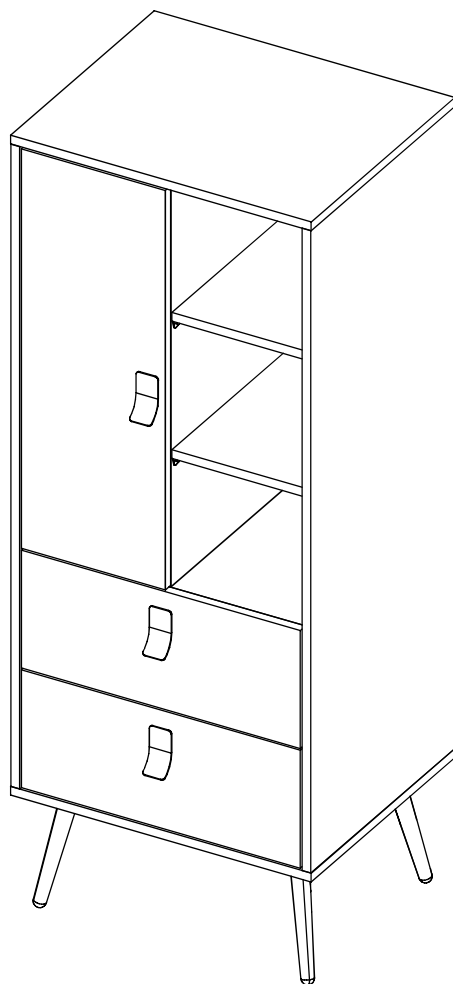

LOT N°

RTA[®]
m u e b l e s

Tel: (602) 695 9581 / 695 91 81 | EXT 118
La Nueva Estancia, Yumbo - Valle del Cauca - Colombia
www.rta.com.co

¡ATENCIÓN! / ATTENTION!

En las próximas páginas está el contenido de las piezas y herrajes del mueble. Asegúrate de que la cantidad de herrajes y piezas que hay en la caja sea la correcta y todo esté en buen estado. Ya que cuando el mueble esté armado no podrás realizar ninguna reposición.

On the next pages is the content of the pieces and hardware of the furniture.

Make sure the number of hardware and parts in the box is correct and everything is in good condition. When the furniture is assembled you will not be able to make any replacement

Recomendaciones Importantes / Key Recommendations

- Ensamble el mueble entre dos personas. / Assemble the cabinet between two people.
- Ensamble el mueble sobre una superficie plana y lisa, preferiblemente sobre un tapete o el cartón de la caja. / Assemble the cabinet on a flat smooth surface, preferably on a carpeted floor or the box carton.
- Se recomienda utilizar un destornillador eléctrico para facilitar el ensamble / It is recommended to use an electric screwdriver to facilitate assembly.

Herramientas Necesarias / Required Tools



Destornillador de estrella
Phillips Head
Screwdriver



Destornillador de pala
Flat Head
Screwdriver

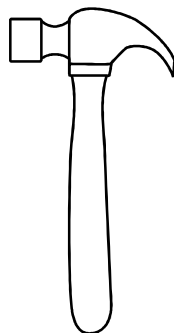

Martillo
Hammer

Herrajes Básicos / Basic Hardware

Aplica estas instrucciones cada vez que vayas a utilizar uno de estos herrajes durante el armado. / Apply these instructions everytime you're using one of these connectors during the assembly.

Tarugos / Wood Dowels

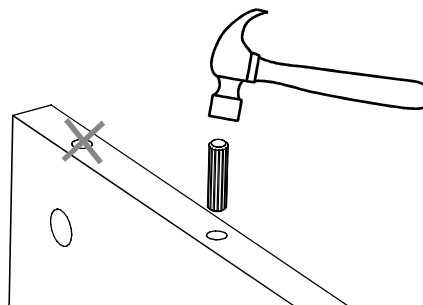

1. Inserta el tarugo en la perforación indicada y golpéalo suavemente hasta que llegue hasta el final de la perforación. / Put in the dowel inside the indicated hole and softly hit it until it's fully inside.

2. Verifica que NO se inserte el tarugo en la perforación de la caja minifix. / Verify that the dowel is NOT inserted into the perforation of the minifix cam.

Minifix y Pernos / Minifix Cam & Spreading Bolt

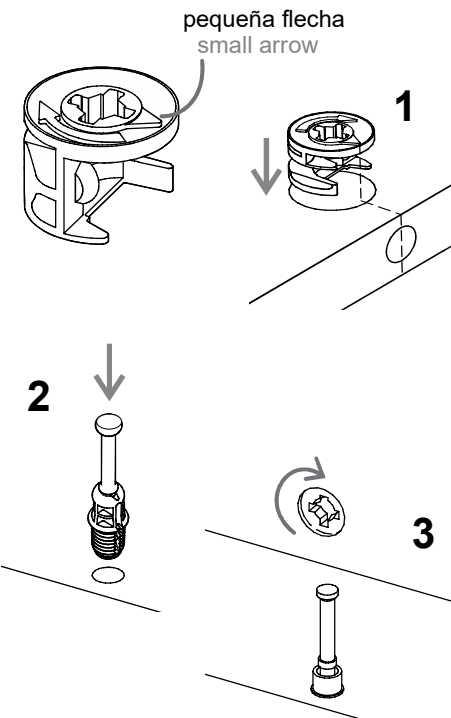

1. La caja minifix tiene una pequeña flecha en su parte superior, se debe insertar las cajas minifix con la flecha apuntando hacia la perforación que hay en el borde de la pieza. / The Minifix cam has a little arrow on its upper surface you should insert these cams with the little arrow pointing towards the drilling on the panel's edge.

2. Se debe insertar el perno con la parte plástica hacia abajo. / The spreading bolt should be put with the black plastic part facing down.

3. Luego de unir las piezas, se deben girar 180° las cajas minifix con un destornillador de estrella para ajustar y asegurar el ensamble. / After joining two panels together you should turn the cams 180° with a phillips head screwdriver to adjust and secure the joint.

Herrajes / Hardware

			
Tarugo / Wood dowel x20	Perno Minifix / Spreading Bolt x28	Caja Minifix / Minifix Cam x28	Tapa Minifix / Cover Caps x24
			
Tapa Adhesiva Minifix / Cover Caps x4	Manija Huna / Handle x3	Tornillo lámina / Flat head screw x24	Tornillo ensamble / Drywall screw x8
			
Puntilla / Nail x30	Soporte esquinero / Corner support x4	Pata de Acero / Steel leg x4	Bisagra interior + tornillos / Inset hinge + Screws x2
			
Soporte entrepaño / Shelf support x12	Kit Antivuelco + Tornillos / Wall Fixing Kit + Screws x2	Rieles + tornillos / Slides + screws x2	Grapa para fondo / Rear Panel Clamp x3

Herrajes / Hardware

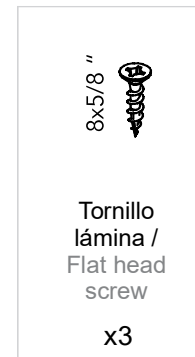

Cargas Máximas / Max Suggested Loads

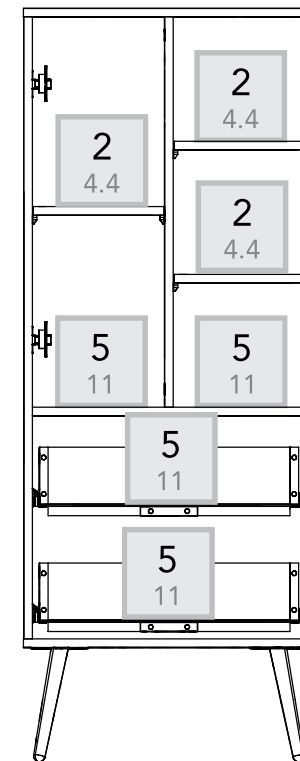

*Peso en Kg / Weight in Kg.

*Peso en Libras / Weight in Lb

Piezas de Armado / Assembly Parts

A - x1
B - x1
C - x1
D - x1
E - x2
F - x2
G - x1
H - x2
I - x2
J - x2
K - x2
L - x2
M - x1
N - x1
O - x1
P - x3

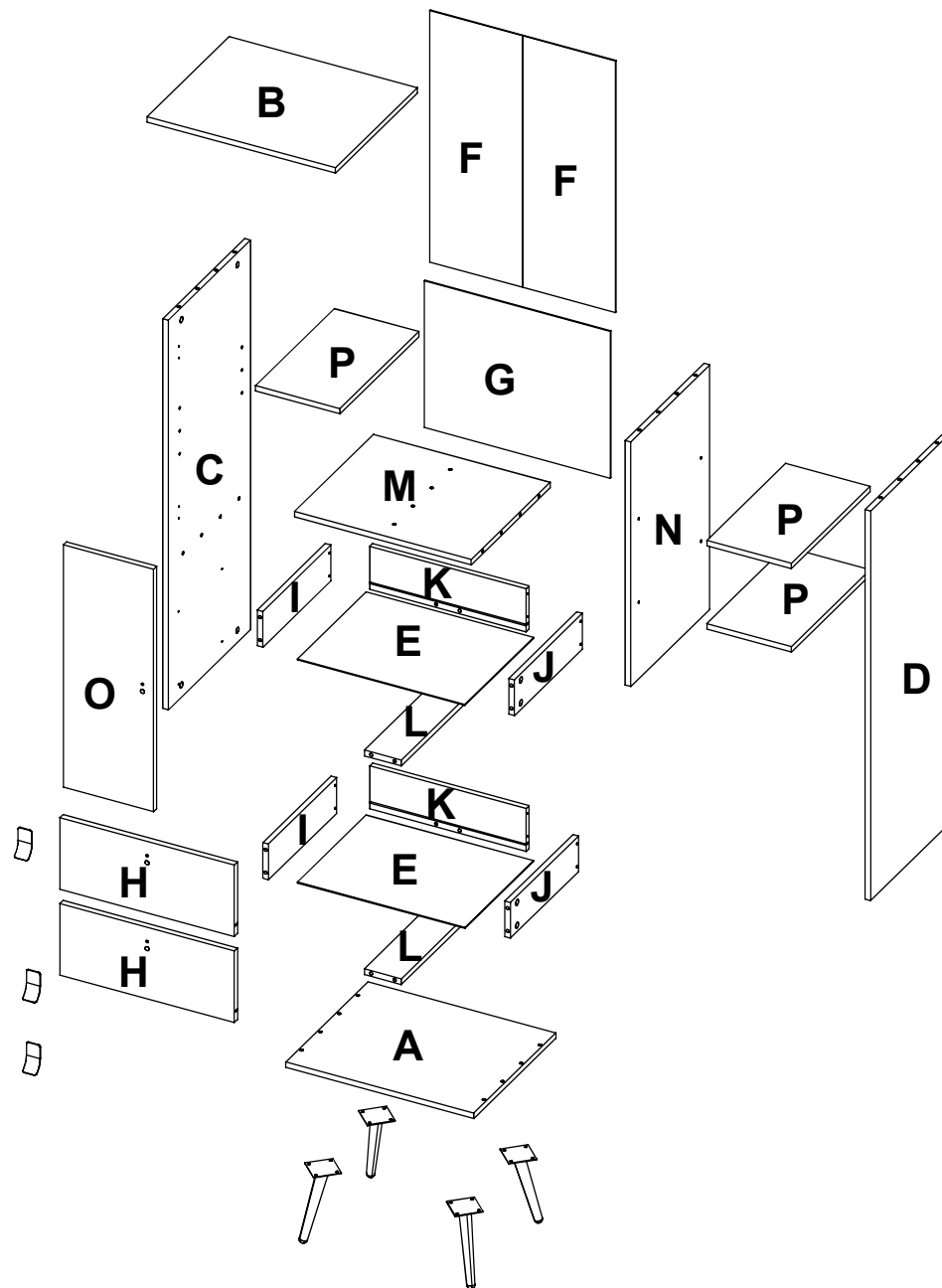

1

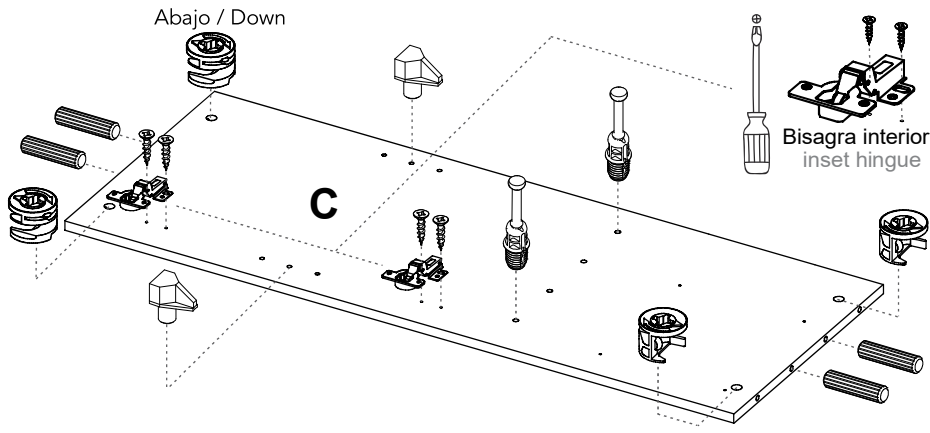

2

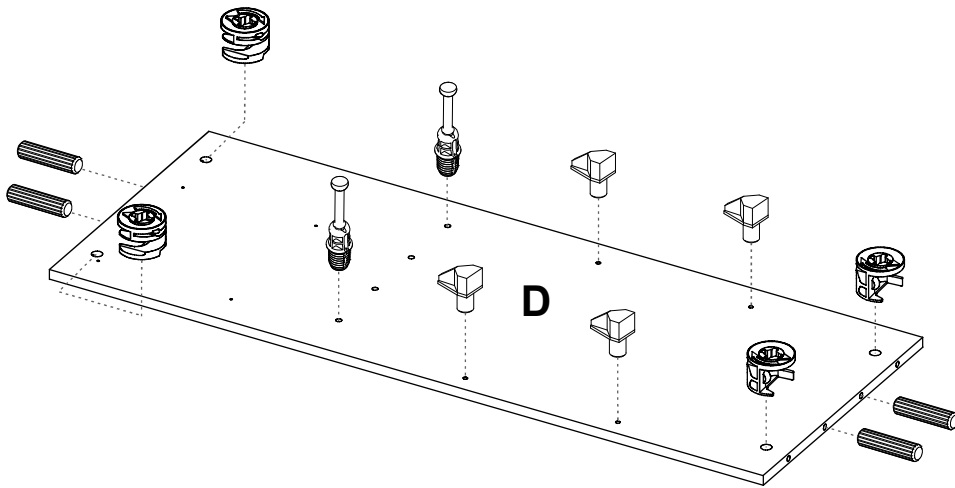

3

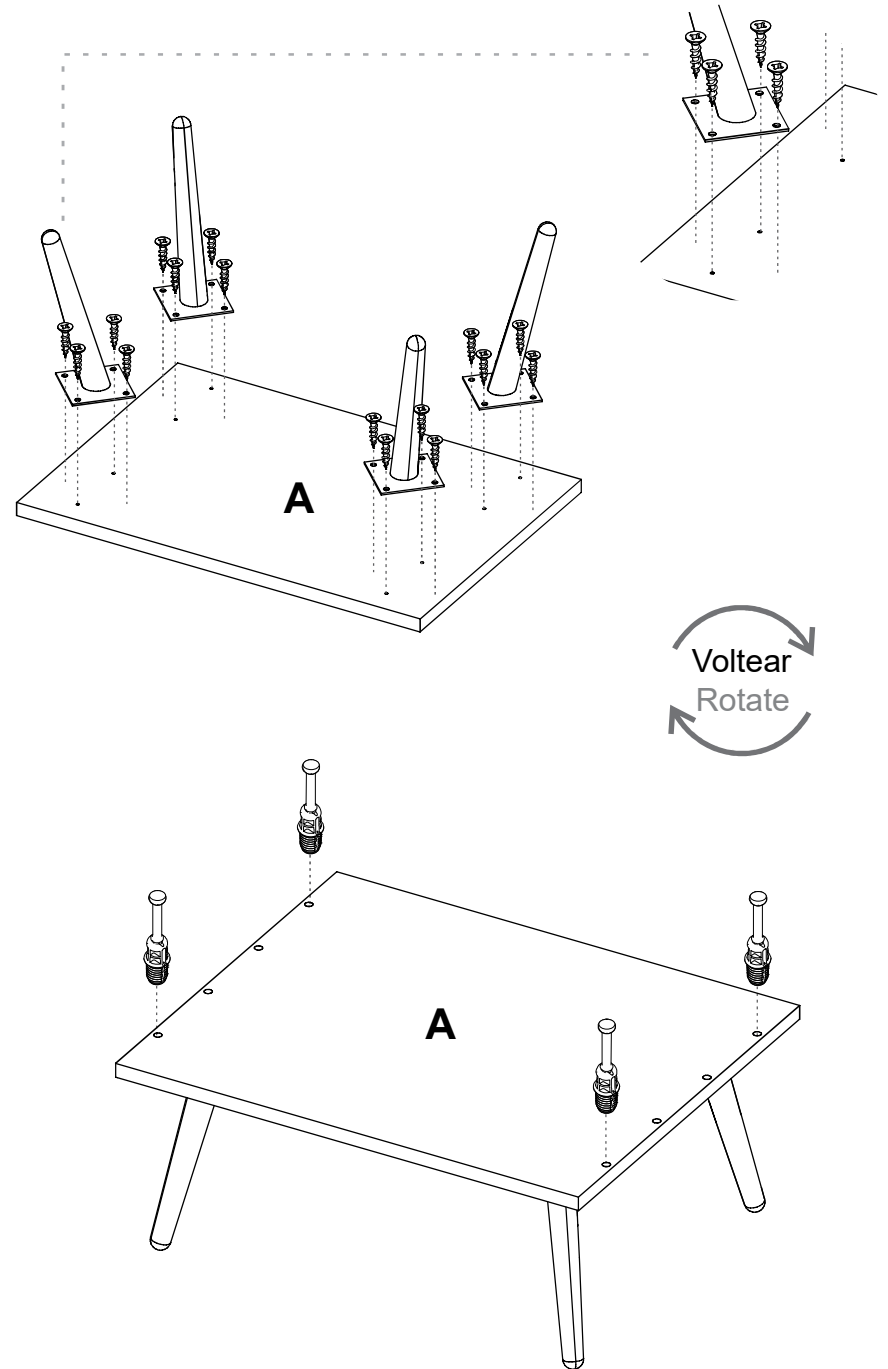

4

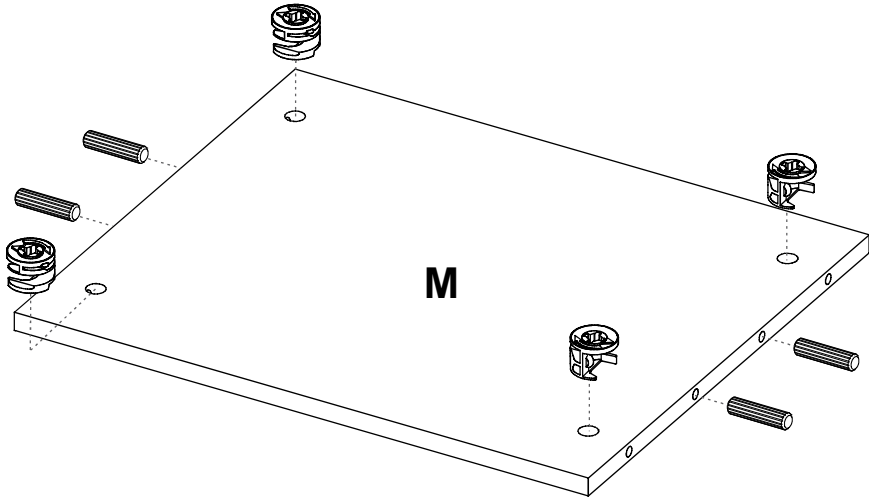

Voltear
Rotate

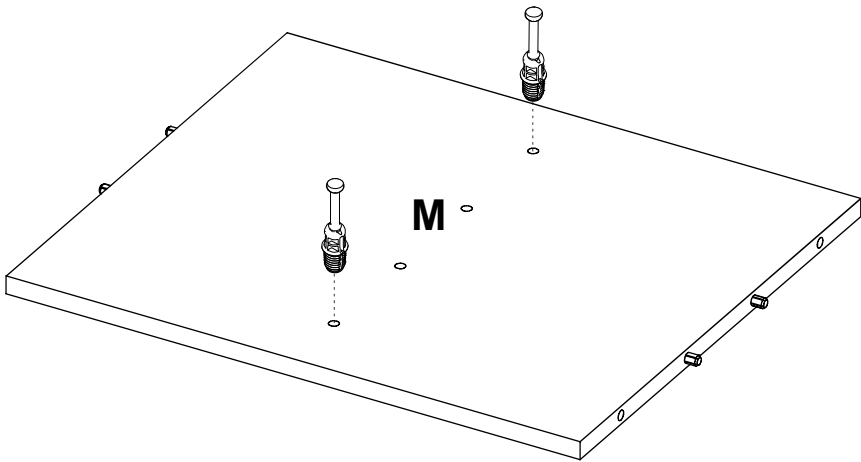

5

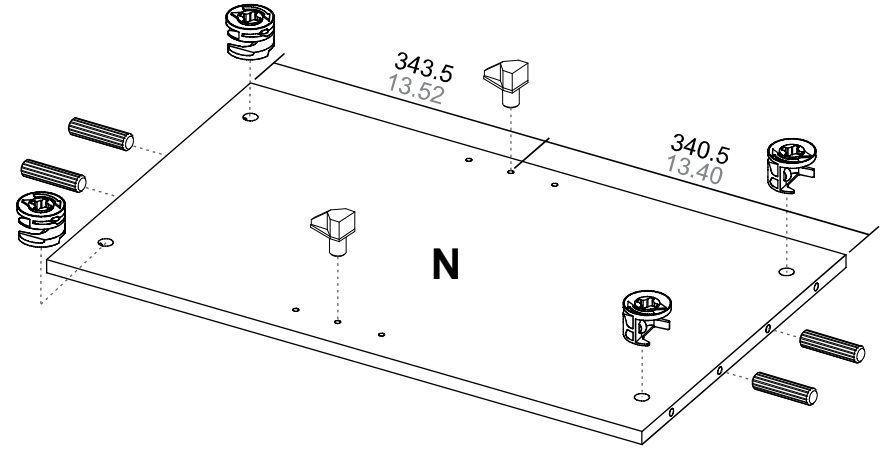

Voltear
Rotate

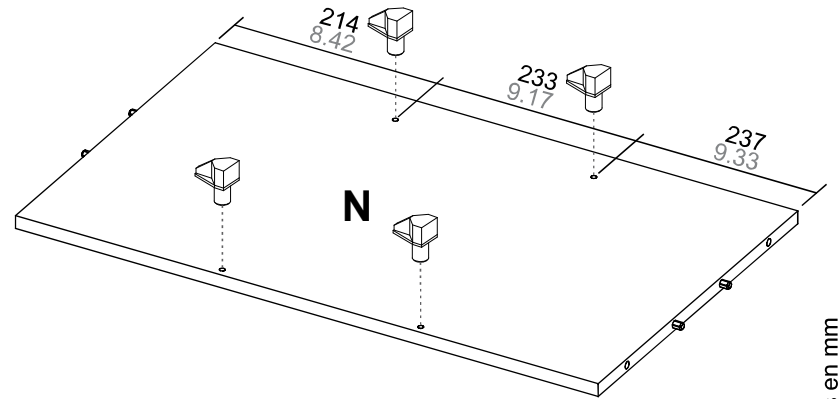

*Medidas en mm
*Dimensions in inches

6

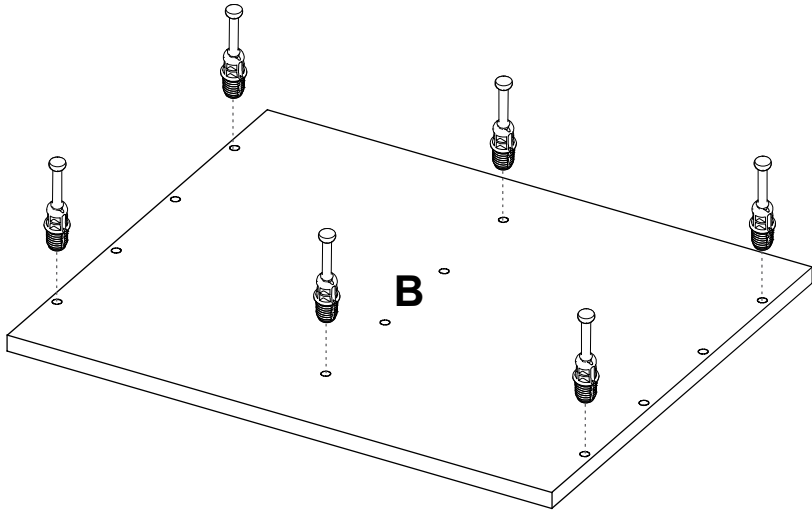

7

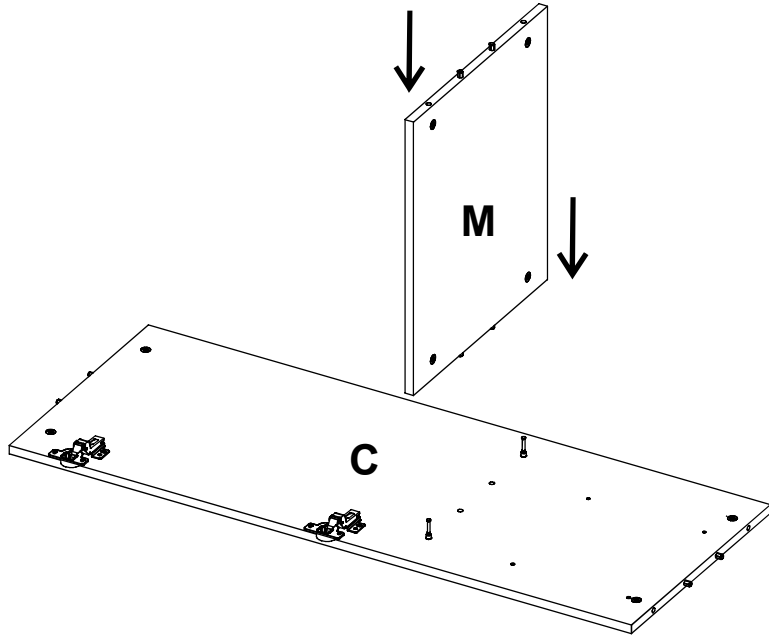

8

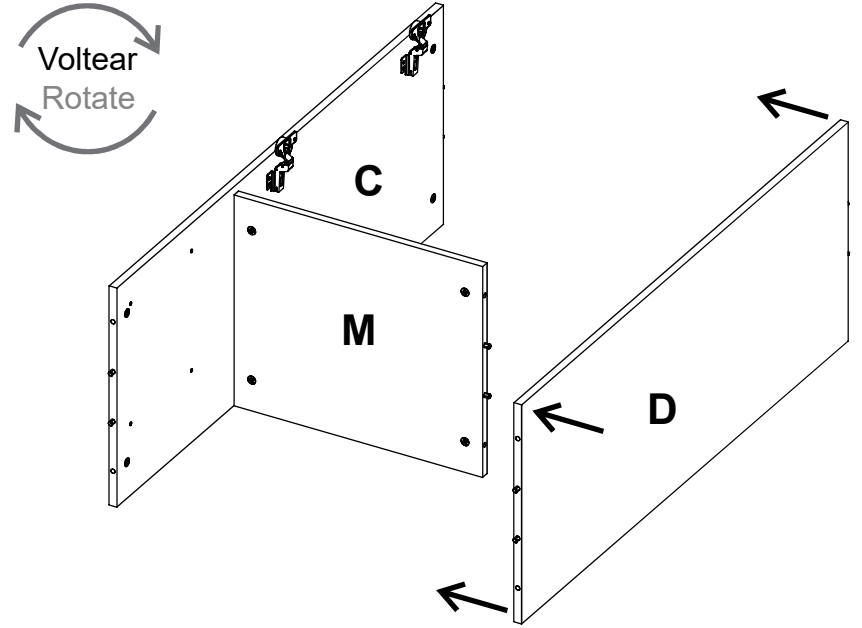

9

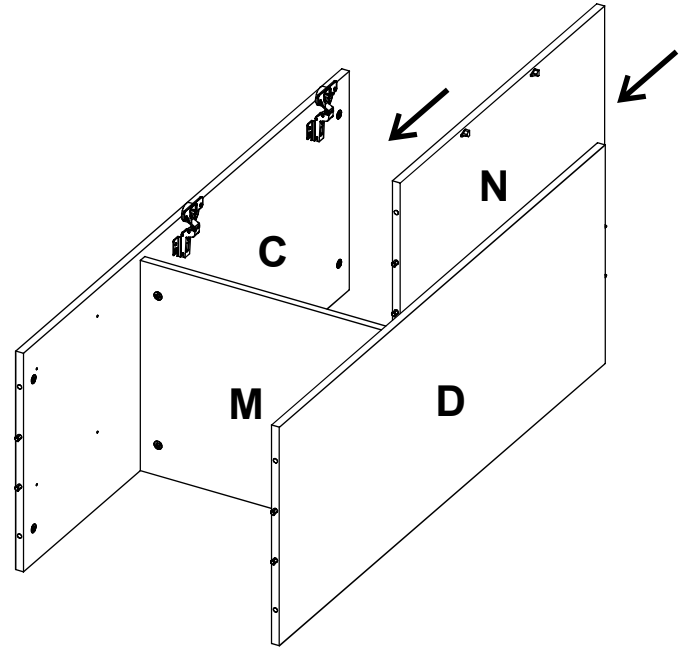

10

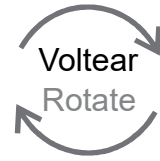
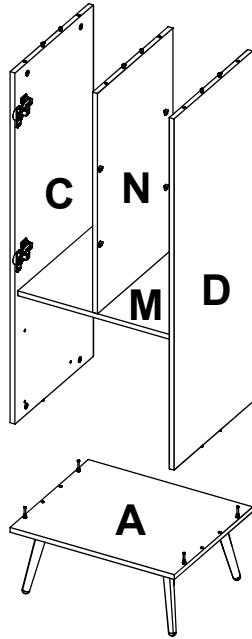

11

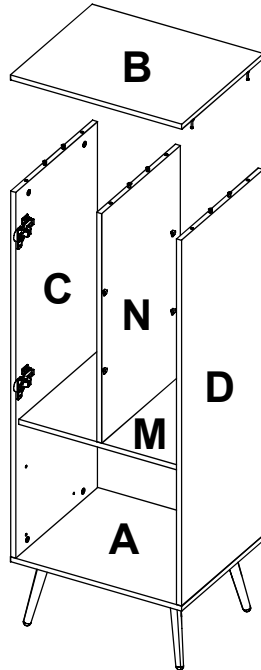

12

¡Con mucho cuidado!
very carefully!

Voltea el mueble
Turn over the cabinet

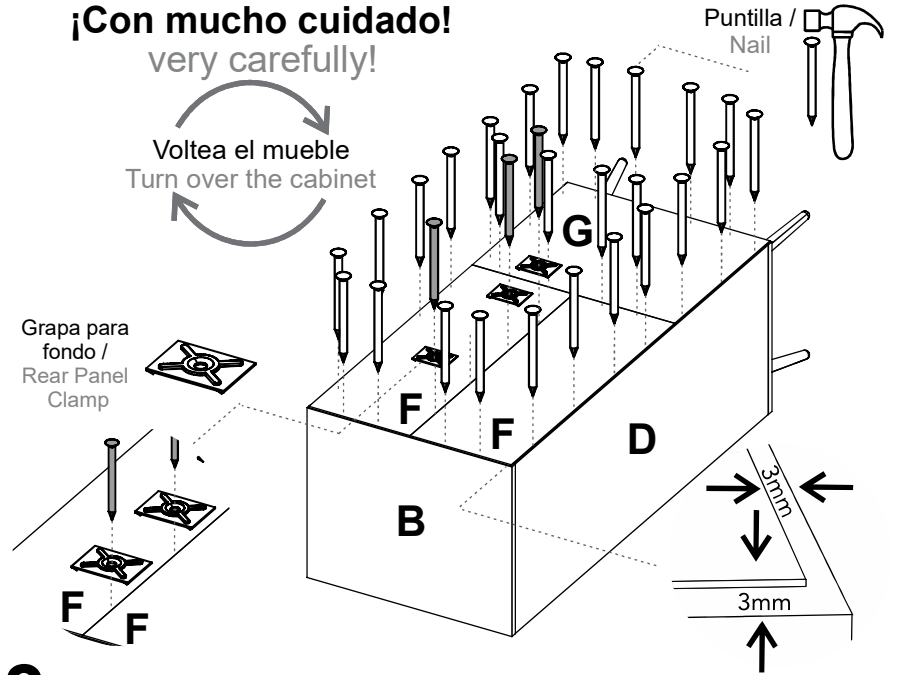

13

¡Con mucho cuidado!
very carefully!

Voltea el mueble
Turn over the cabinet

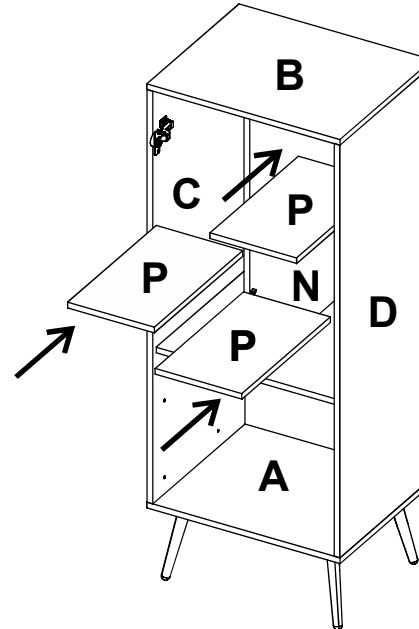

14

Instalación de los rieles

La rueda debe ir hacia la parte del frente de la pieza y hacia abajo, así:

Drawer slides installation

The wheel should go towards the front edge of the panel and facing down, like this:

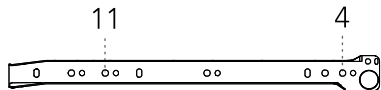
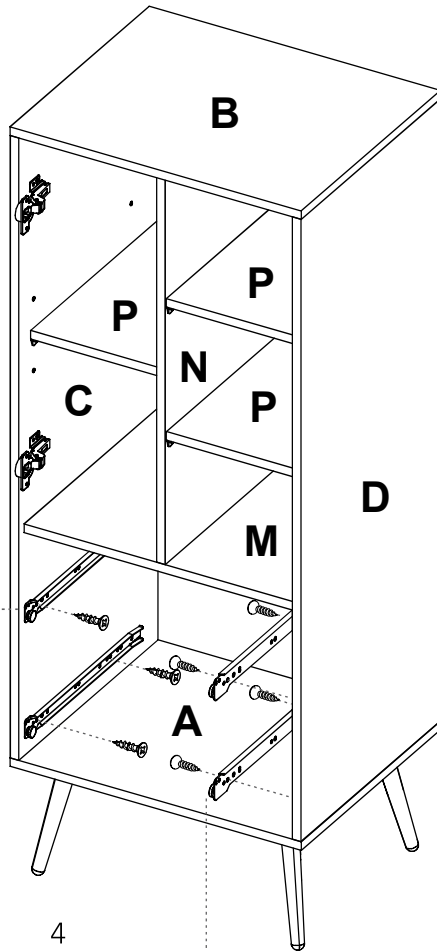
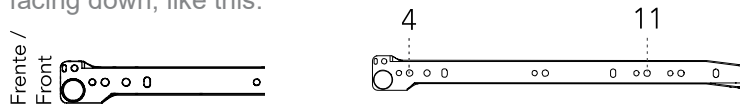

15

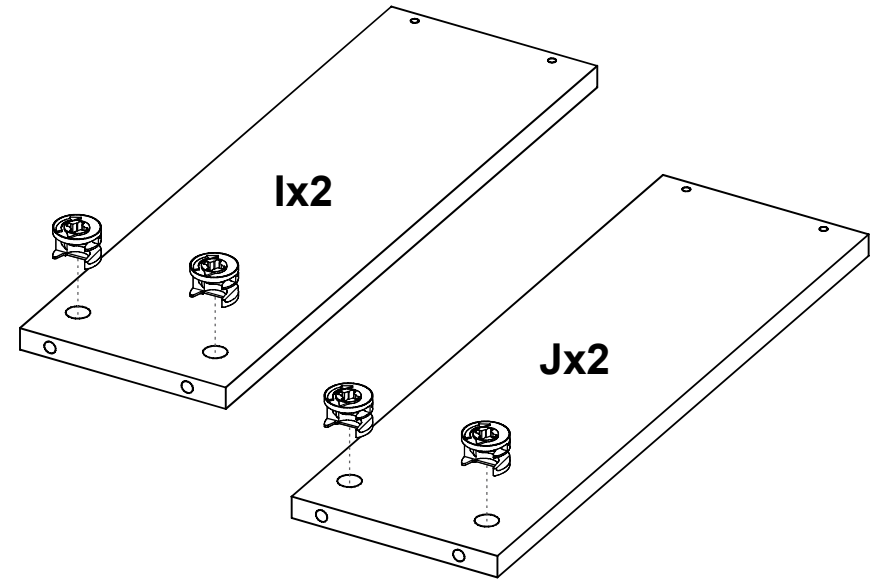

16

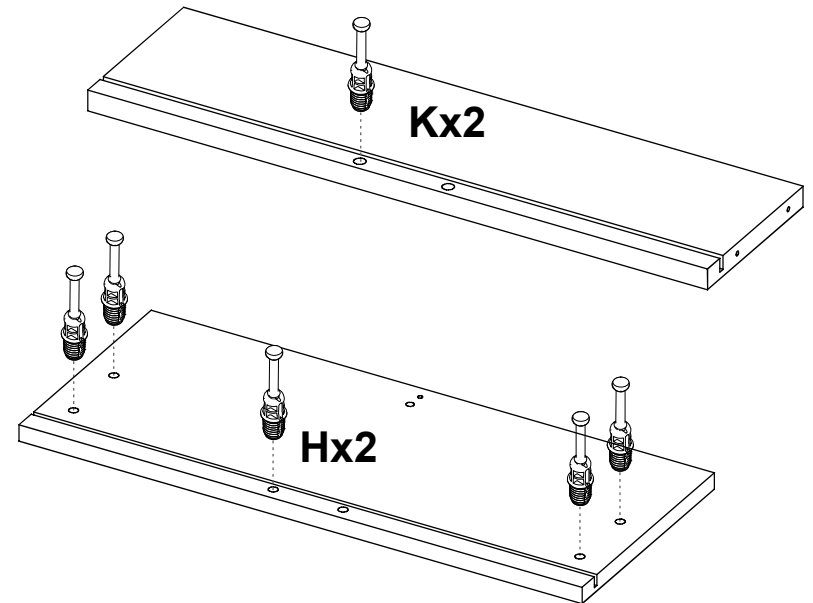

17x2

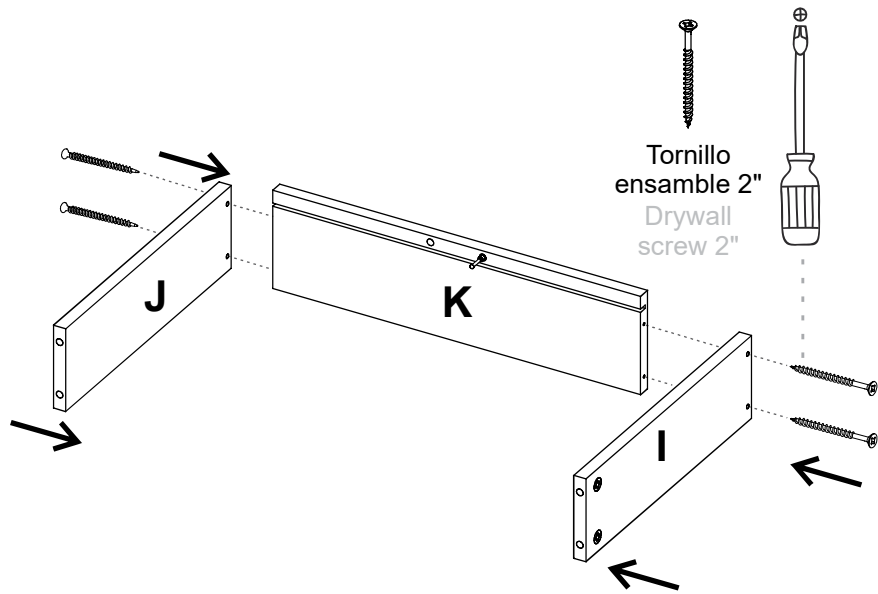

19

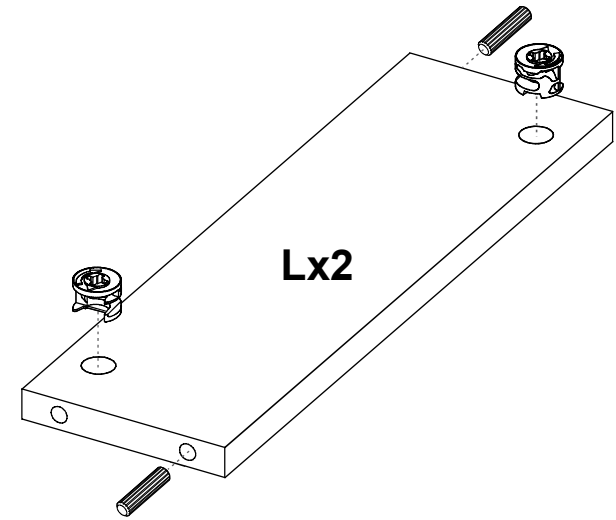

18x2

Desliza el fondo dentro de las ranuras.
Slide the back panel inside the grooves.

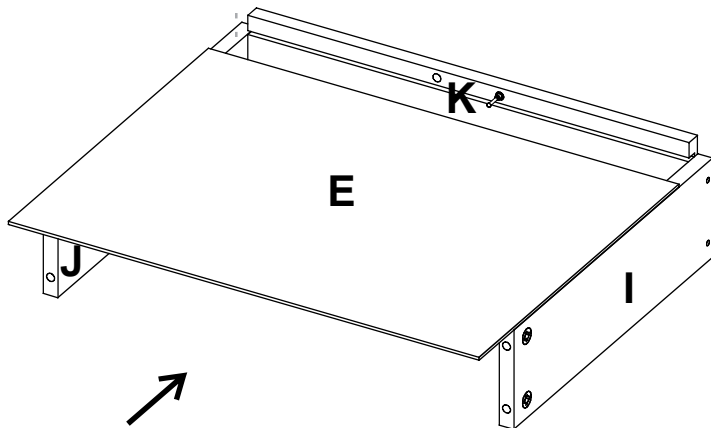

20x2

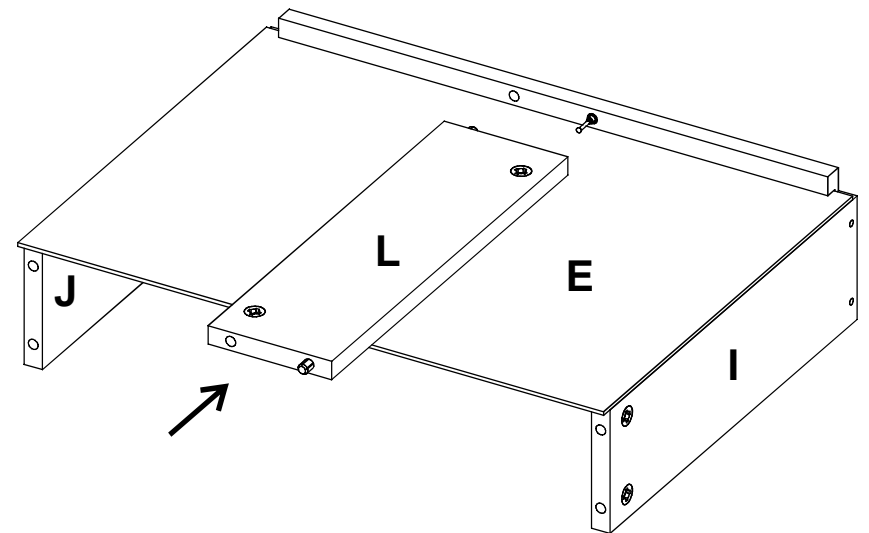

21x2

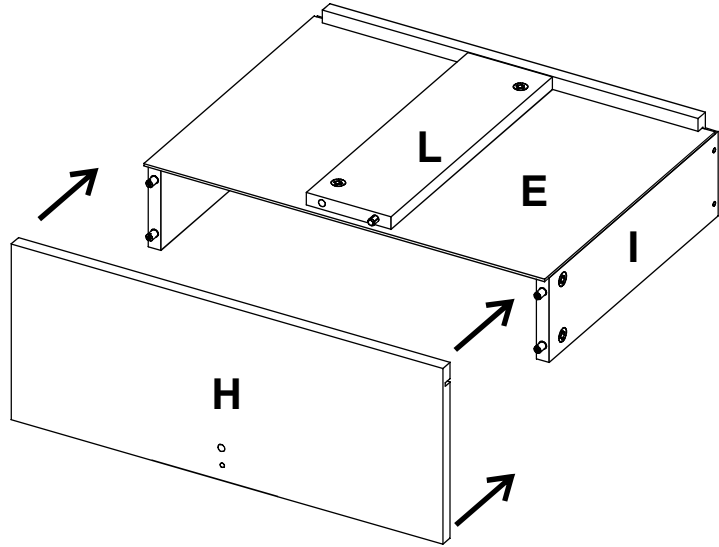

22x2 Instalación de los cajones Drawer Installation

La rueda del riel
debe ir en la parte
trasera del cajón.
The wheel should go
on the rear part of
the drawer.

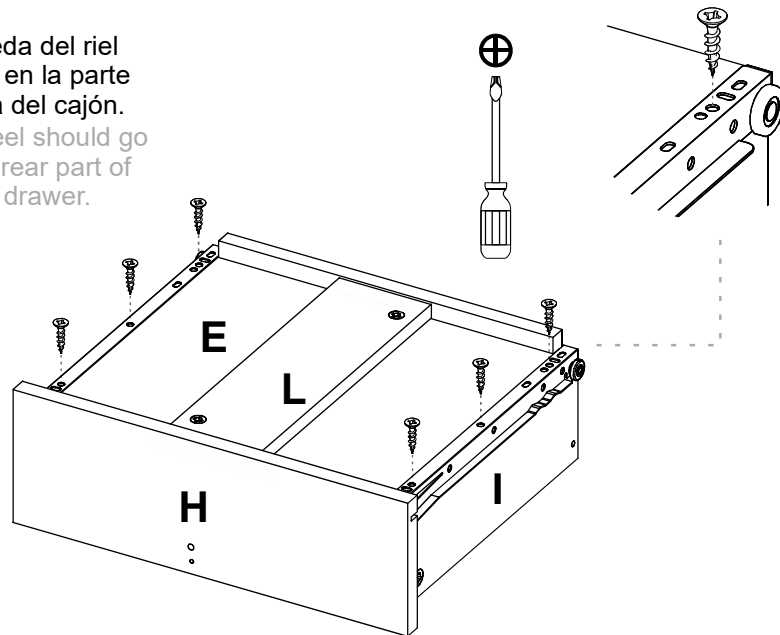

23

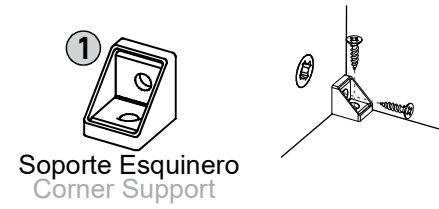

Soporte Esquinero
Corner Support

Ubicar los soportes esquineros
en los lugares señalados y
atornille con tornillo lamina 9/16"
Place the corner supports
in the indicated locations and
screw with flat head screw 9/16"

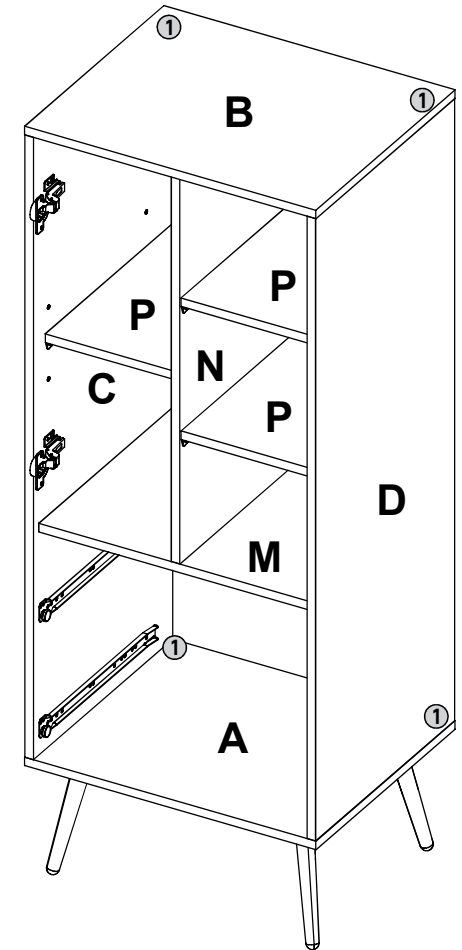
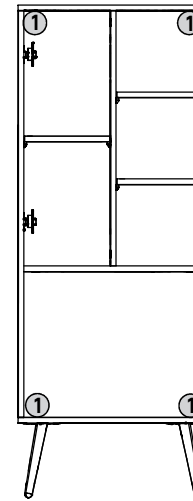

24 Instalación de los cajones Putting the drawers in

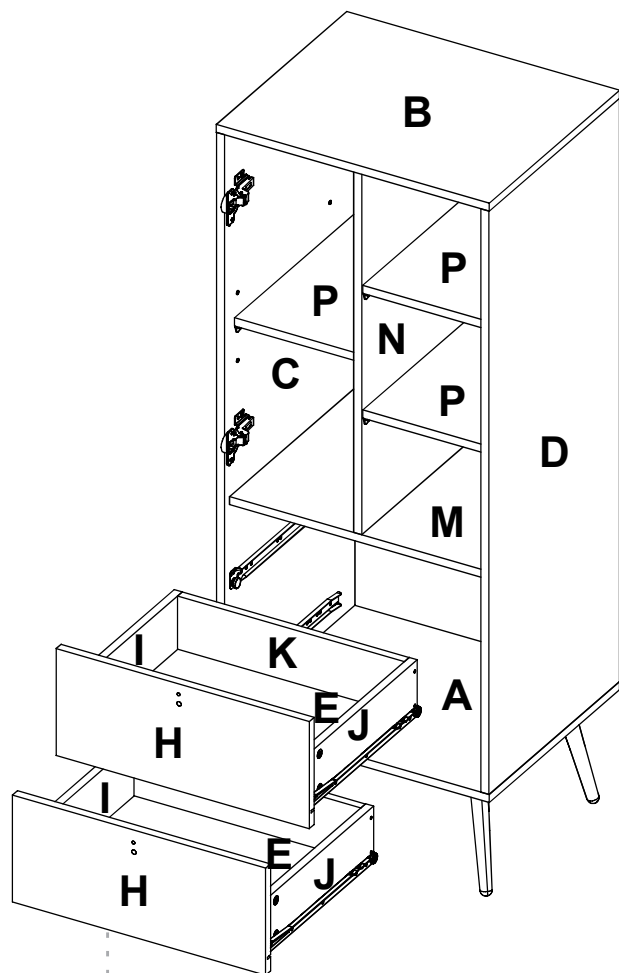

Desliza los cajones dentro del mueble.

Slide the drawers inside the cabinet.

25 Fija el mueble a la pared Fix your cabinet to the wall

- 1** Haz una perforación en el borde superior de la parte superior del mueble y fija un extremo de la correa con el tornillo de 15mm y una arandela.
Make a small hole on the top edge of the furniture top and fix one side of the strap with the 15mm screw and the washer.



- 2** Dobra a 30 mm la correa y mide en la pared para perforar.
Fold the strap to 30 mm and measure on the wall to drill.

- 3** Perfora la pared a 30mm de profundidad con una broca de 6mm.
Drill a hole in your wall to a depth of 30mm using a 6mm drill bit.

- 4** Inserta el chazo plástico en la perforación.
Insert the plastic wall anchor into the hole.

- 5** Fija el otro extremo de la correa con la arandela y el tornillo que sobran.
Fix the other side of the strap with the screw and the washer.

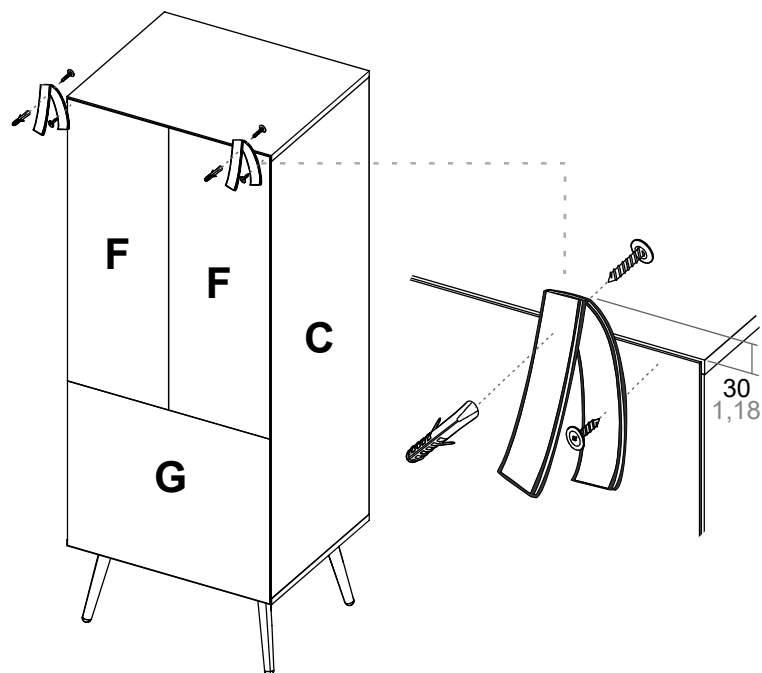



*Medidas en mm
*Dimensions in inches

26

Instalación de la puerta Door Installation

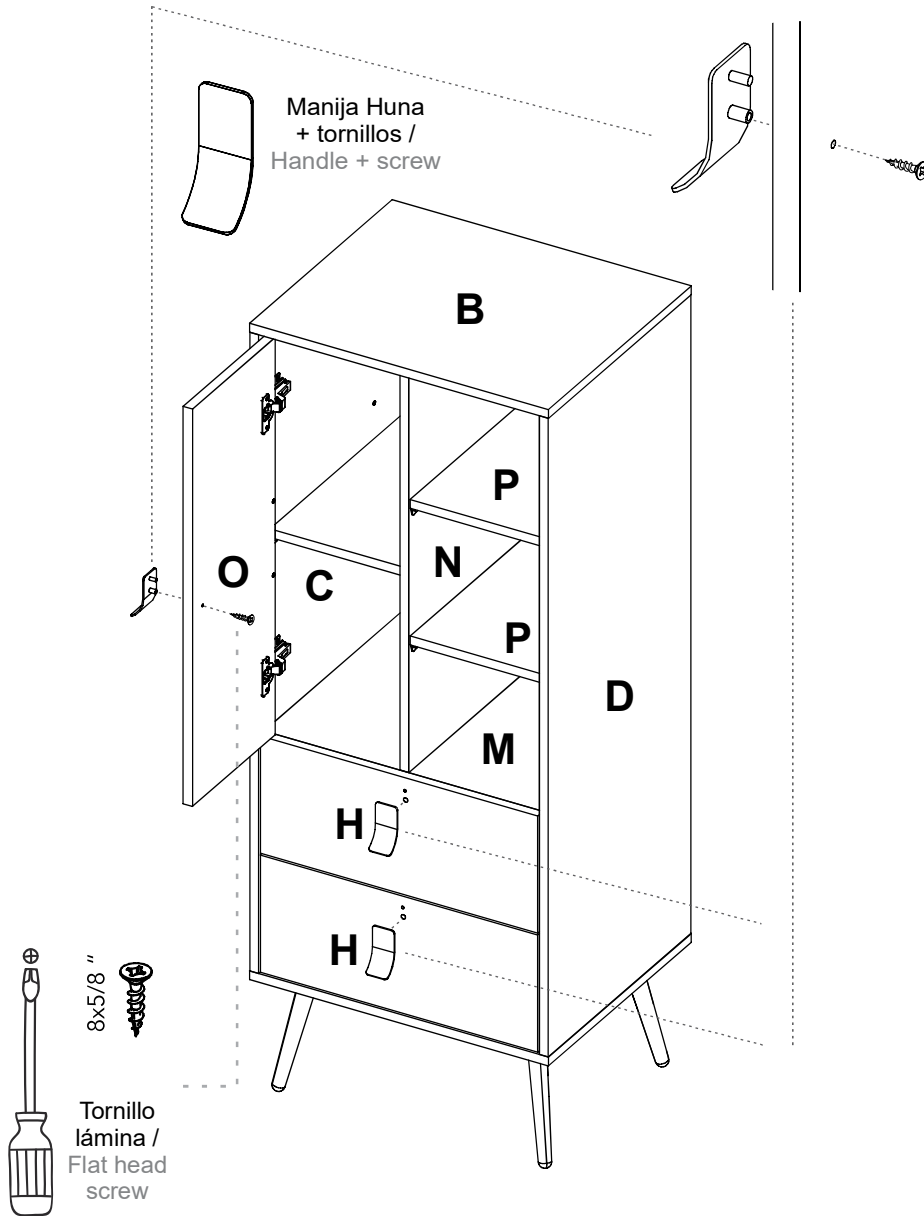

Seguir las instrucciones de ajuste de la siguiente pagina.
Follow the adjustment instructions on the next page. →

27

Ajuste de las bisagras Hinge adjustment

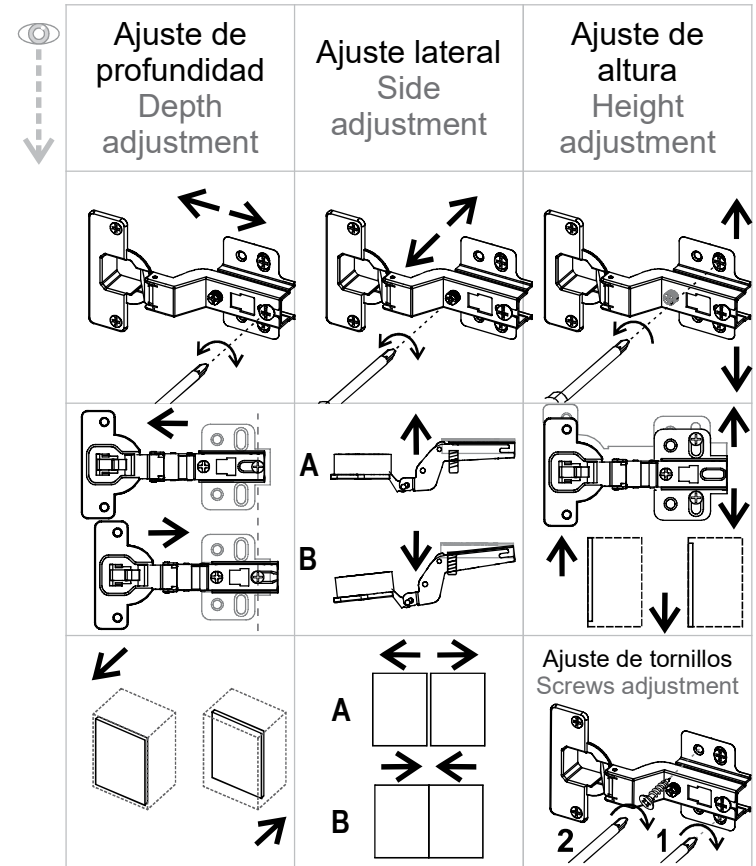

Usar los ajustes según la necesidad específica.
Use the settings according to the specific need.

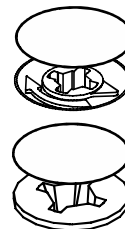

Después de ajustar todas las
cajas minifix y los tornillos,
cúbralas con las tapas adhesivas.
After you finish the adjustment
of the cams and screws,
cover them with the
cover caps.

A

Al terminar de armar,
desprenda las letras
adhesivas.
After you finish
assembling the cabinet,
take off the adhesive
letters.