

**ROMP QUEEN BED**



# **ROMP**





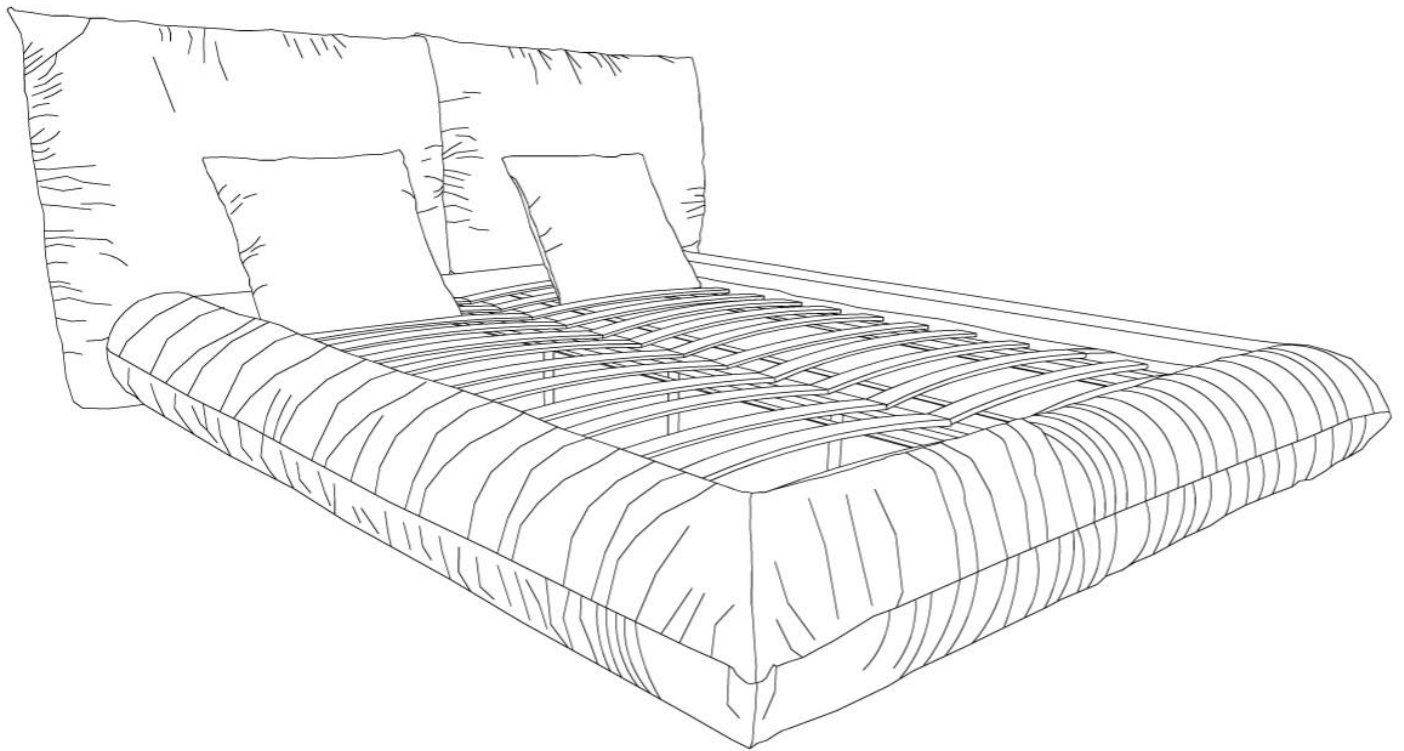



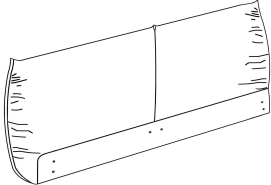

---





## **Assembly Instructions**

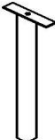

## PARTS LIST

Hardware included in side rails carton to attach bed feet and center support system.

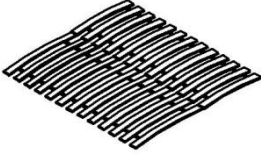
LABEL	PICTURE	DESCRIPTION	QTY
A		HEADBOARD	1
B		FOOTBOARD	1
C		SIDE RAILS RIGHT	1
D		SIDE RAILS LEFT	1
E		WASHER $\Phi 8\text{mm}$	20
F		BOLT $\Phi 8*30\text{mm}$	20
G		BRACKET	2
H		BRACKET	2
I		ALLEN KEY	1
J		CENTER SUPPORT LEG H=20.8CM	3
K		WASHER $\Phi 6\text{mm}$	3

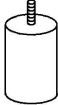
L		BOLT $\Phi$ 6*25mm	8
M		BOLT $\Phi$ 6*40mm	3
N		SLAT	26
O		CENTER SUPPORT RAIL	1
P		BED LEG H=5CM	4

### BEFORE BEGINNING ASSEMBLY:



*Read instructions cover to cover*



*Have two adults on hand for assembly*



*Do NOT assemble on flooring or carpet. Assemble on a clean non-marring surface (ex: packing foam)*



*Save all packaging until assembly is completed*

*Need a part? Call TOV at 516-888-3355 or email [service@tovfurniture.com](mailto:service@tovfurniture.com)*

## ASSEMBLY STEPS

### STEP 1

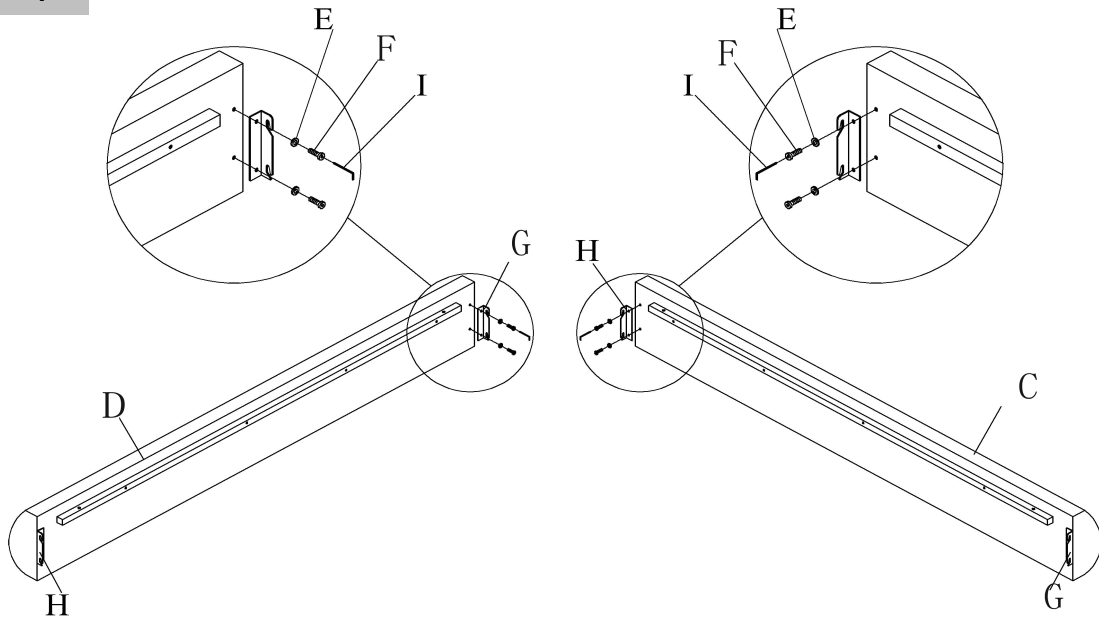

- > Retrieve bracket from parts' carton packed in side rails carton.  
Attach bracket (H) & (G) to the side rails using Bolt (F) and Washer (E) , Tighten the bolts with Allen key (I) .

### STEP 2

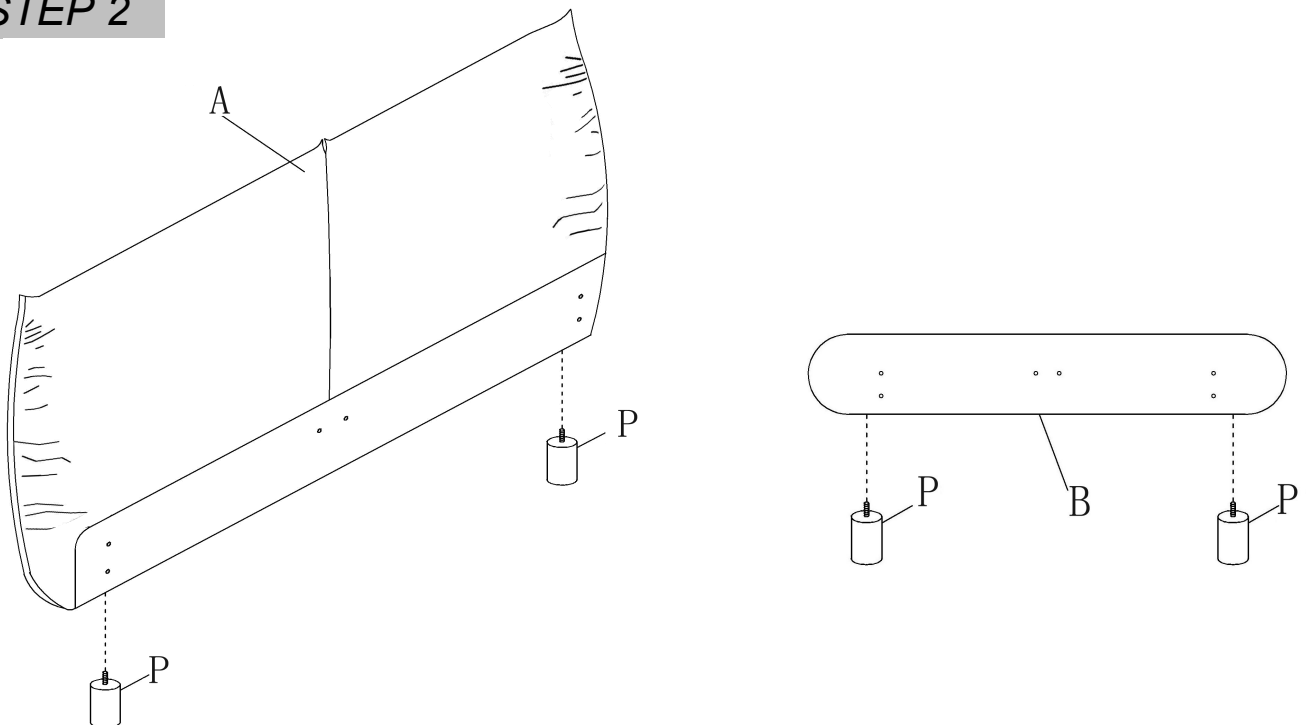

- > Retrieve Bed legs from parts' carton packed in side rails carton.  
Attach Bed legs (P) to Headboard & Footboard.

### STEP 3

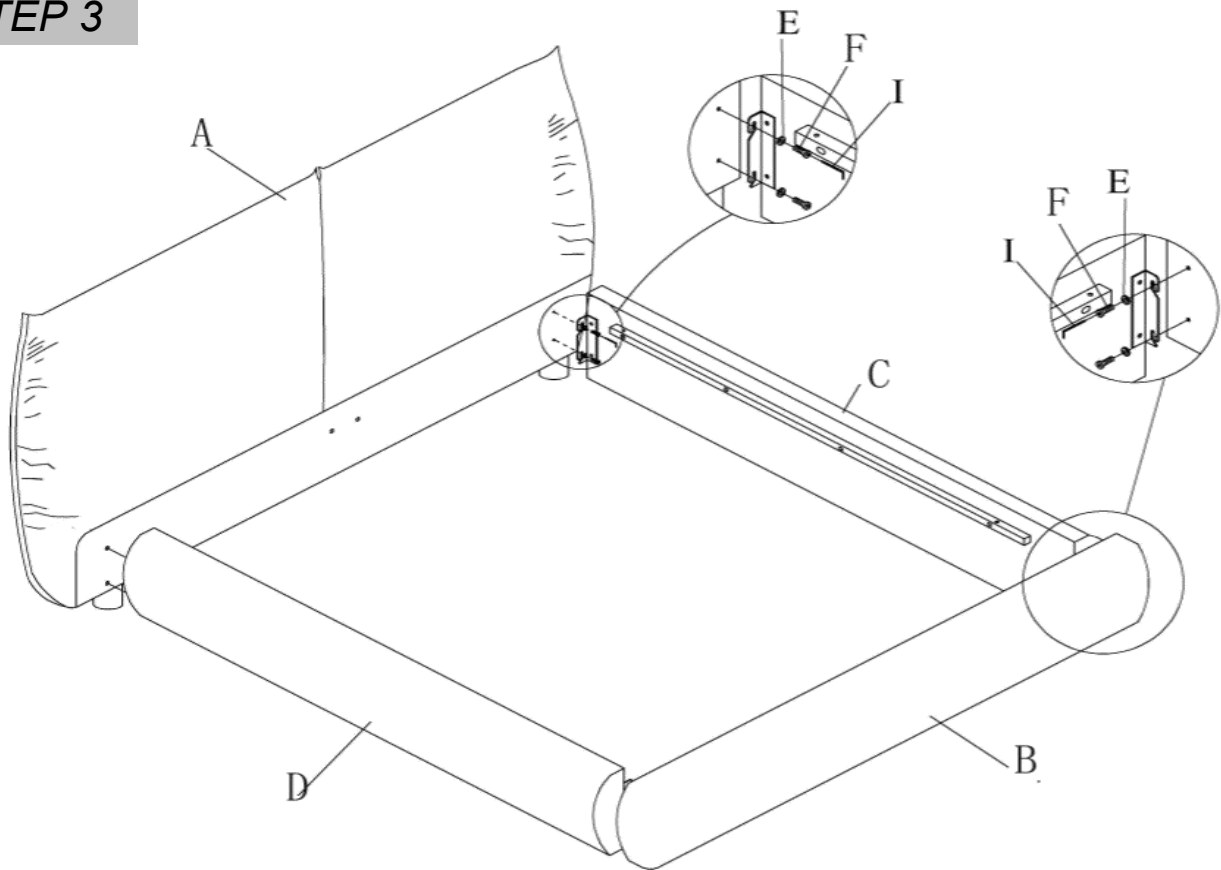

- > Attach side rails to headboard & footboard using Bolt (F) and Washer (E). First twist the screw in, then slot the brackets over the bolts, Tighten the bolts with Allen key (I)

### STEP 4

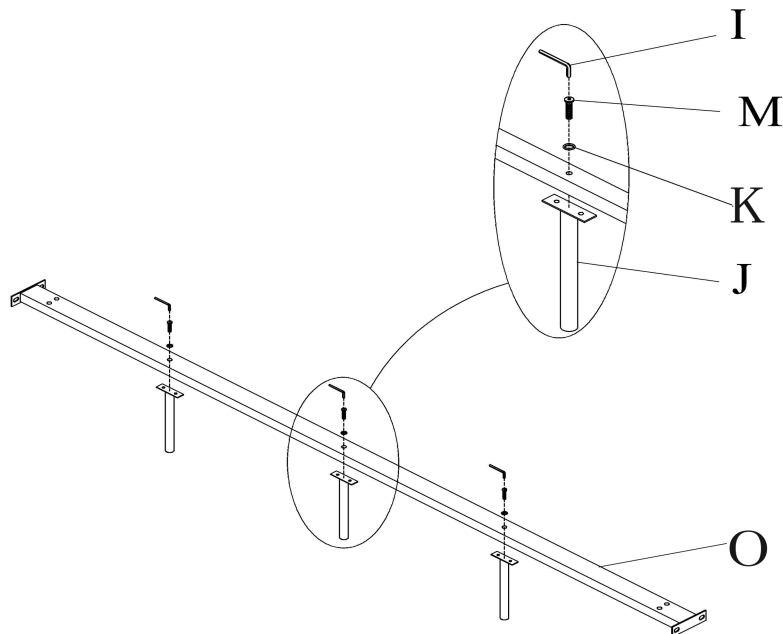

- > Attach steel center support legs (J) to the center support rail (O) using Allen key (I), Bolt (M) and Washer (K).

## STEP 5

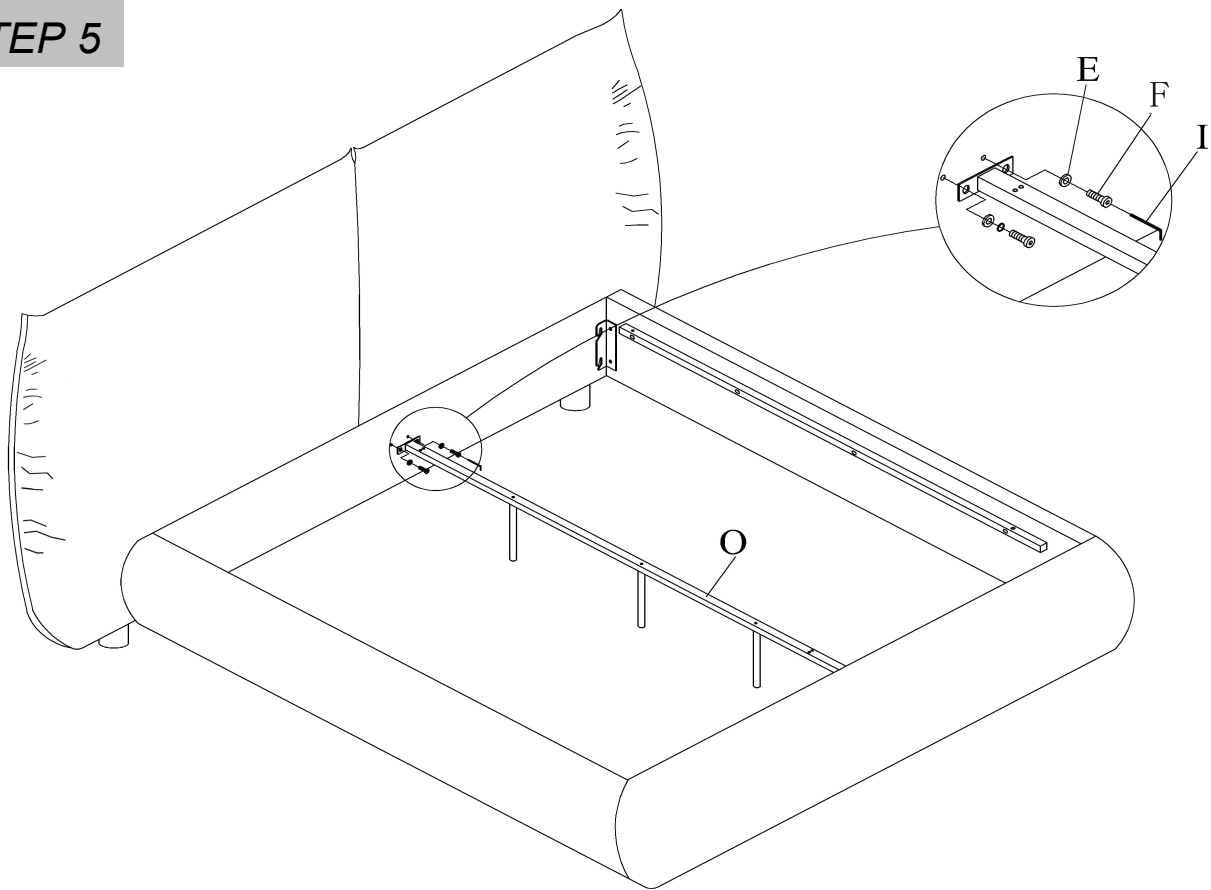

- > Attach center support rail (O) to the Headboard and footboard using Allen key (I), Bolt (F) and Washer (E). Please line up the holes in the center support rail (O) and refit the bolts & washers, tighten the bolts with Allen key (I) .  
Verify the center support legs are perpendicular to the floor for full support.

## STEP 6

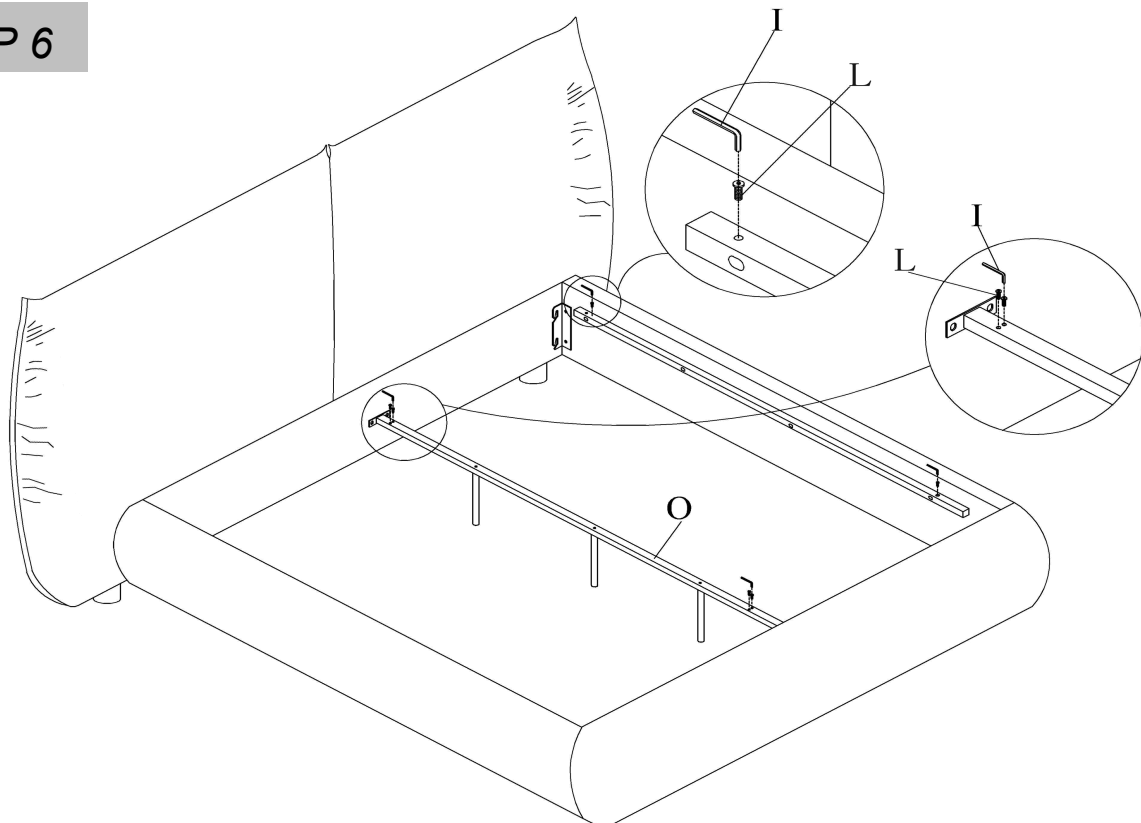

- > Attach Bolt (L) to the holes in the end of support rails using Allen key (I). (\*Please note that the bolt only needs to be twisted half in and leave half out .)

## STEP 7

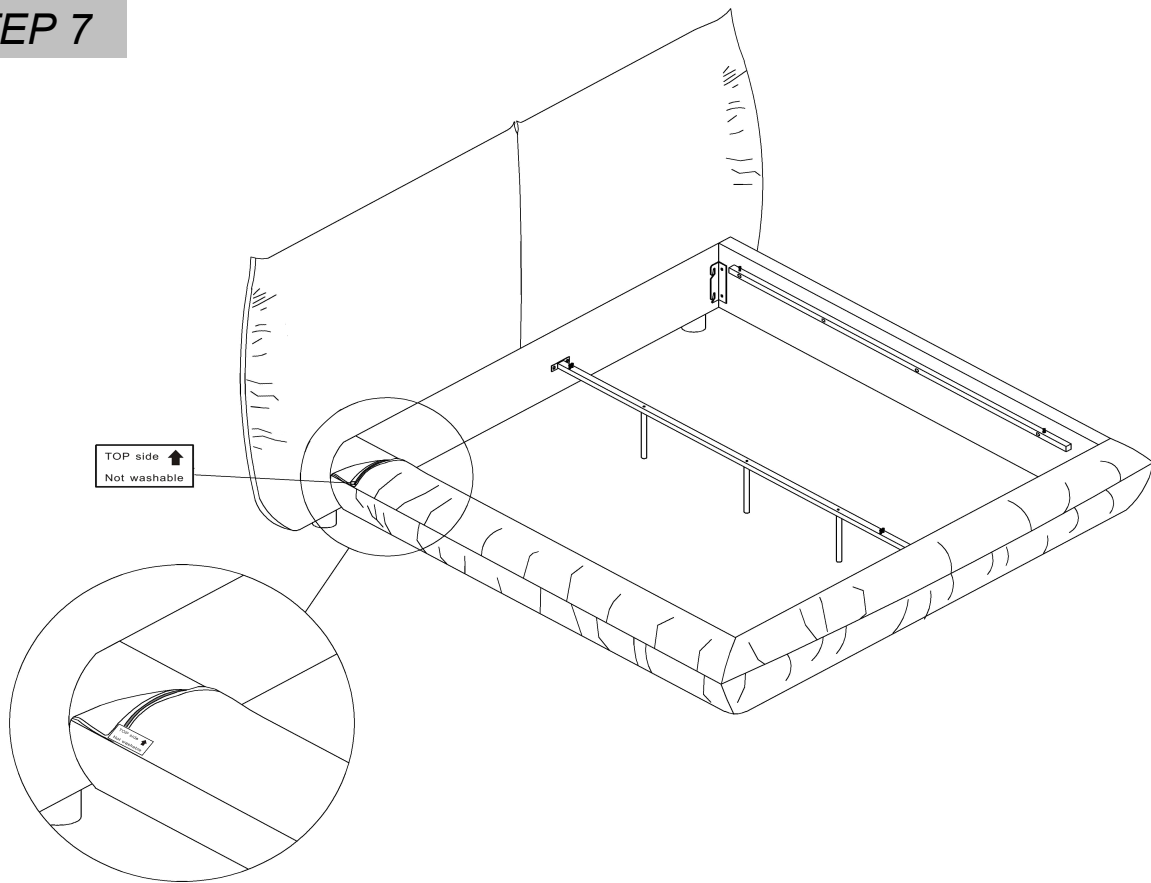

> Attach the slip cover to the side rails and footboard. The side of the cloth cover with the sewn label is affixed to the top of bed frame

## STEP 8

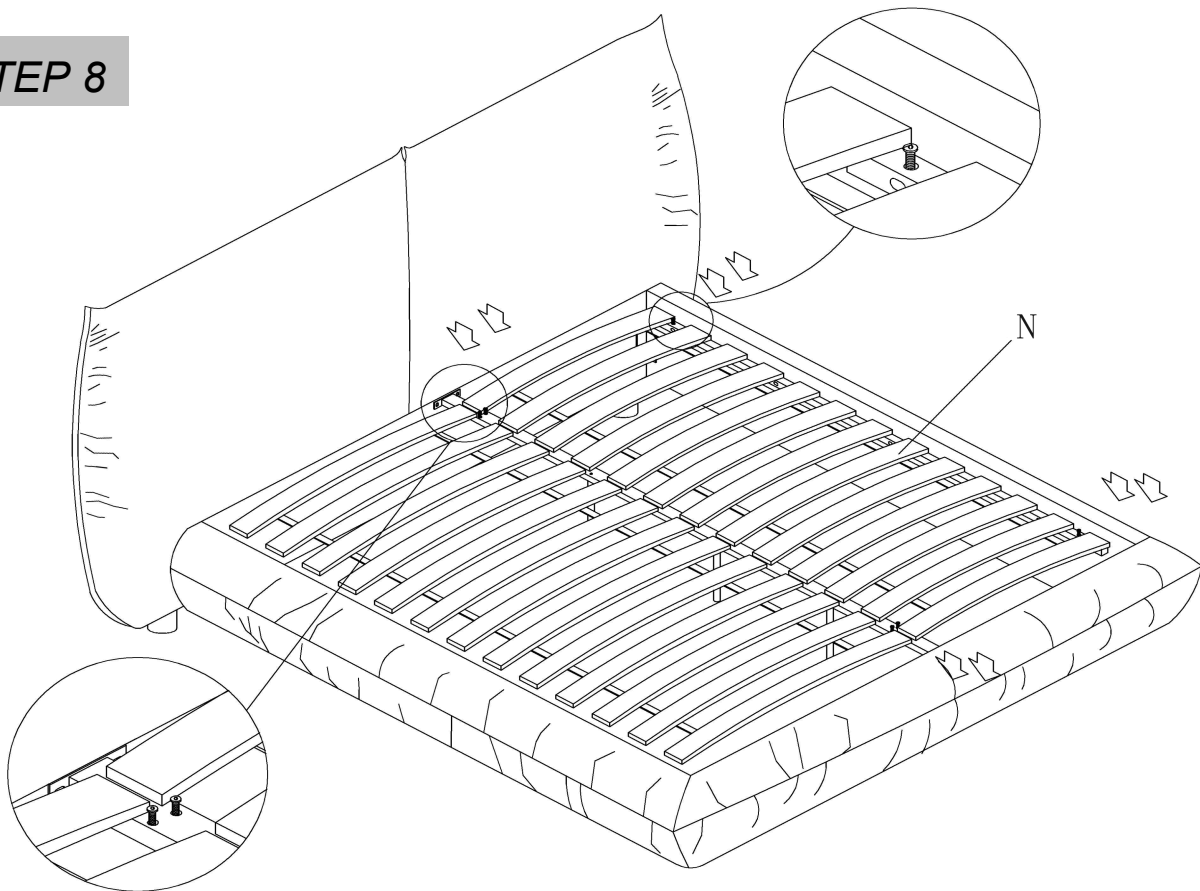

> Move/place bed into final position in bedroom.  
Attach wooden slat support system to full length steel support cleats.  
Verify the slats are installed properly and stuck by the bolt (L) .

## CARE & MAINTENANCE



Do not put hot items directly on furniture surface.



Do not clean furniture with harsh cleansers or polish.



Dust and wipe up spills using a clean, non-colored, lint-free cloth.



Stains may be removed with mild soap solution and a damp cloth



Do not place furniture under direct sunlight.



Do not place furniture near heating or cooling vents.



Do not write on furniture without a padded barrier to protect the surface.



Do not place furniture outside, for indoor use only.