

# #916 CLASSIC 16 GUN CABINET ASSEMBLY INSTRUCTIONS



 **American**  
Furniture *Classics*

Thank you for purchasing this quality product. A list of PARTS and INSTRUCTIONS is included to assist you. Unpack and identify all parts included on the Parts List and Hardware List. If parts are missing, please DO NOT return this item to the store. For faster service please call our **Customer Service Department at 1-888-673-9080**. For efficient and speedy service, please indicate the model number and code letter of part(s) needed.











# #916 CLASSIC 16 GUN CABINET ASSEMBLY INSTRUCTIONS

**American**  
Furniture Classics

## HARDWARE LIST

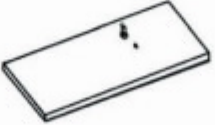
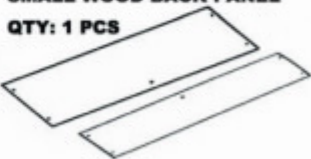
- |  |  |   |
|--|--|---|
| <p>1  <b>SHELF LOCK</b><br/>QTY: 20 PCS</p> | <p>2  <b>DOOR KEY</b><br/>QTY: 1 SET</p>    | <p>3  <b>SHELF SUPPORT</b><br/>X 20 PCS</p>    |
| <p>4  <b>DOOR HANDLE</b><br/>QTY: 2 PCS</p> | <p>5  <b>WRENCH</b><br/>X 1 PCS</p>         | <p>6  <b>PLASTIC WASHER</b><br/>QTY: 4 PCS</p> |
| <p>7  <b>M6X11 LCK</b><br/>QTY: 8 SETS</p>  | <p>8  <b>M6X11 RND</b><br/>QTY: 10 SETS</p> |   |

## PARTS LIST

- |  |   |  |
|--|---|--|
| <p>A <b>METAL BACK PANELS</b><br/>QTY: 2 PCS</p>  | <p>E <b>TOP PANEL</b><br/>QTY: 1 PCS</p>         | <p>J <b>SMALL BARREL REST</b><br/>QTY: 1 PCS</p>    |
| <p>B <b>LEFT SIDE PANEL</b><br/>QTY: 1 PCS</p>    | <p>F <b>SMALL LEFT DOOR</b><br/>QTY: 1 PCS</p>   | <p>K <b>LARGE BARREL REST</b><br/>QTY: 1 PCS</p>    |
| <p>C <b>RIGHT SIDE PANEL</b><br/>QTY: 1 PCS</p>   | <p>G <b>LARGE RIGHT DOOR</b><br/>QTY: 1 PCS</p>  | <p>L <b>LARGE WOOD BACK PANEL</b><br/>QTY: 1 PCS<br/><b>SMALL WOOD BACK PANEL</b><br/>QTY: 1 PCS</p>  |
| <p>D <b>BOTTOM PANEL</b><br/>QTY: 1 PCS</p>       | <p>H <b>ADJUSTABLE SHELF</b><br/>QTY: 4 PCS</p>  | <p>M <b>CENTER PANEL</b><br/>QTY: 1 PCS</p>   |

## CUSTOMER SERVICE

Toll Free 888-673-9080 • Fax 417-673-9081 • E-mail [service@americanfurnitureclassics.com](mailto:service@americanfurnitureclassics.com)

# #916 CLASSIC 16 GUN CABINET ASSEMBLY INSTRUCTIONS

**American**  
Furniture Classics

STEP

1



**A METAL BACK PANEL**

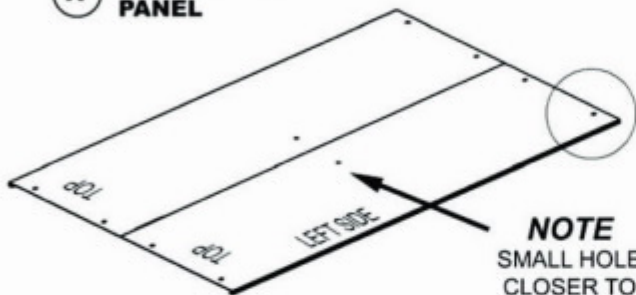

**NOTE**  
SMALL HOLE  
CLOSER TO  
LEFT SIDE

LAY METAL BACK PANELS ON FLOOR WITH INSIDE OF BACK PANEL FACING UP.

STEP

2

**NOTE**  
HOLES/SLOTS IN  
CABINET SIDES FOR  
ADJUSTABLE SHELF  
BARREL REST MUST  
BE TOWARD TOP  
OF CABINET

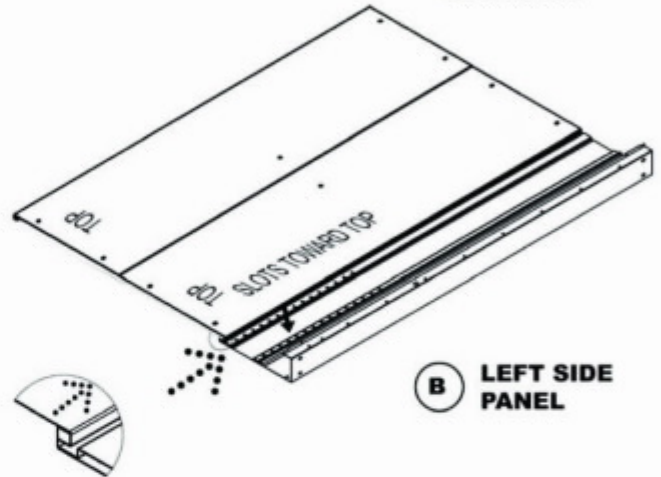

**B LEFT SIDE PANEL**

HOOK / ATTACH LEFT SIDE PANEL TO BACK PANEL.

STEP

3

**C RIGHT SIDE PANEL**

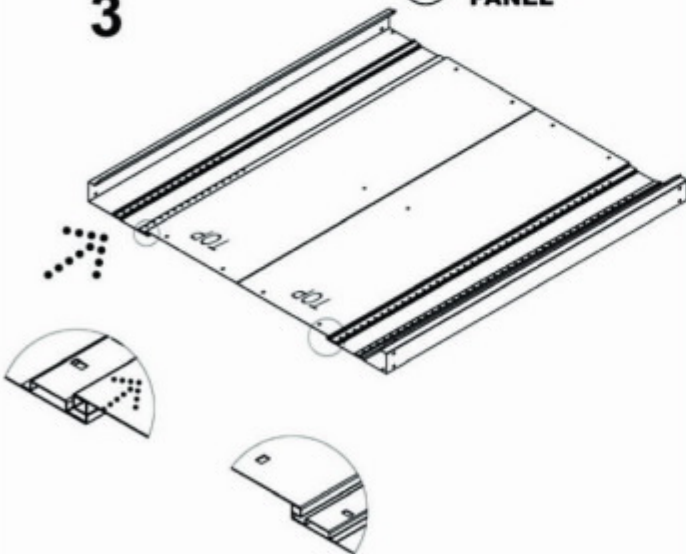

HOOK / ATTACH RIGHT SIDE PANEL TO BACK PANEL.

STEP

4

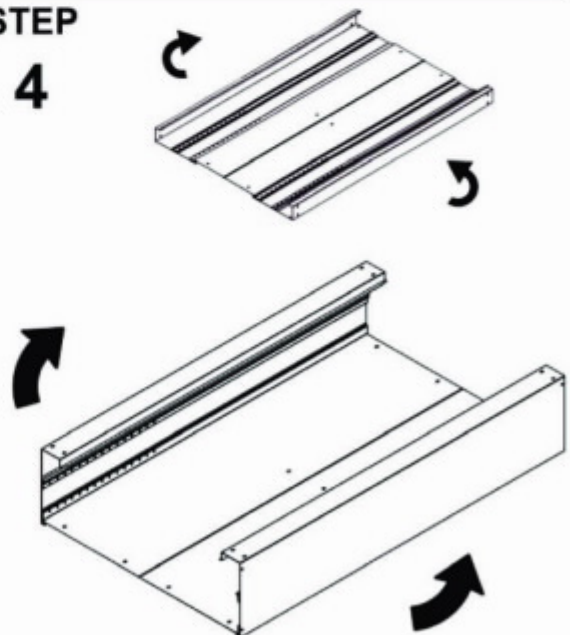

ROTATE FRONT EDGE OF BOTH SIDE PANELS UPWARD TO FORM RECTANGULAR CABINET SHAPE.

# #916 CLASSIC 16 GUN CABINET ASSEMBLY INSTRUCTIONS

**American**  
Furniture Classics

## STEP

### 5

**IMPORTANT**  
DO NOT FULLY TIGHTEN THE  
BOLTS DURING THIS STEP.

**D BOTTOM PANEL**



**M6X11 LCK  
QTY: 4 SETS**

SLIDE BOTTOM PANEL OVER THE SIDE AND BACK  
PANELS. INSERT 4 - M6X11 BOLTS THROUGH FRONT AND  
LOOSELY TIGHTEN WASHER & LOCK NUTS FROM INSIDE.

## STEP

### 6

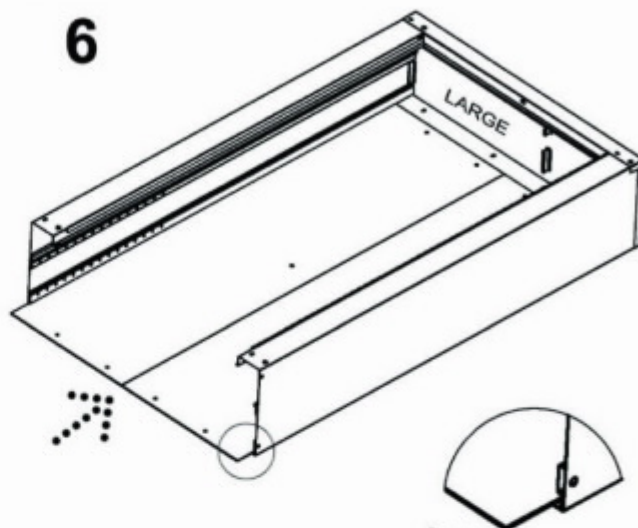

**L SMALL & LARGE WOOD  
BACK PANEL**

INSERT AND SLIDE 2 WOOD BACK PANELS INTO PLACE  
FROM TOP END OF CABINET.

## STEP

### 7



**M CENTER  
PANEL**



SLIDE CENTER PANEL OVER THE WOODEN BACK PANEL.

## STEP

### 8

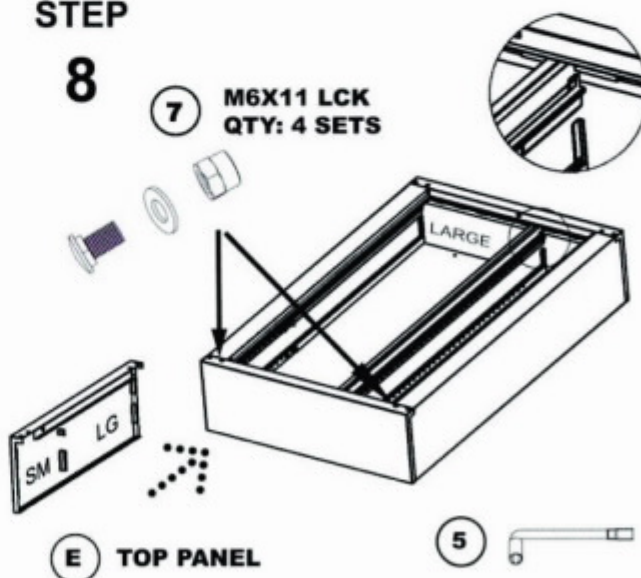

**E TOP PANEL**

SLIDE TOP PANEL OVER THE SIDE, CENTER AND BACK  
PANELS. INSERT 4 - M6X11 BOLTS THROUGH FRONT AND  
FULLY TIGHTEN WASHER & LOCK NUTS FROM INSIDE  
USING M6 WRENCH.

# #916 CLASSIC 16 GUN CABINET ASSEMBLY INSTRUCTIONS

**American**  
Furniture Classics

STEP

9

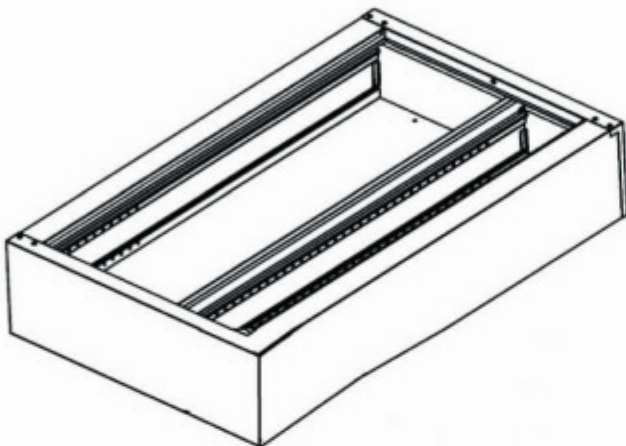

RETURN TO BOTTOM PANEL AND FULLY TIGHTEN THE 4 - M6X11 BOLTS FROM INSIDE USING THE M6 WRENCH.

STEP

11

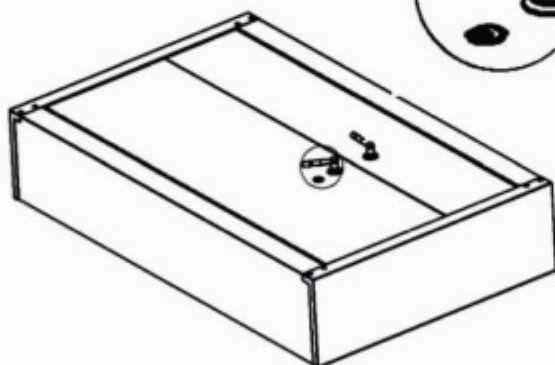

4



**DOOR HANDLE**  
**QTY: 2 PCS**

SCREW LOCK HANDLE INTO DOORS. OPEN AND CLOSE DOOR TO CONFIRM PROPER ALIGNMENT.

STEP

10

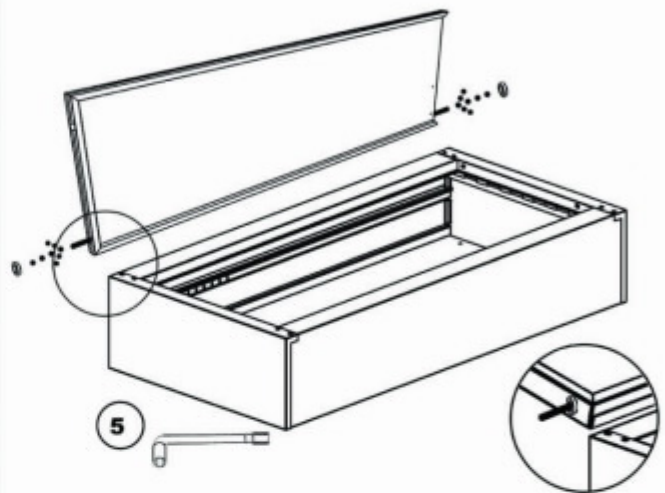

DOOR IS EQUIPPED WITH TOP AND BOTTOM "SPRING" HINGE PINS.

SLIDE PLASTIC WASHER(6) ONTO EACH HINGE PIN.

INSERT THE HINGE PIN ON ONE END OF THE DOOR.

INTO THE HINGE PIN HOLE IN THE CABINET DOOR FRAME.

POSITION THE OTHER END OF THE DOOR AND THE OTHER HINGE PIN NEAR THE HOLE IN THE OPPOSITE END OF THE DOOR FRAME.

PUSH DOWN ON THE HINGE PIN SO THAT IT RETRACTS INSIDE THE DOOR.

WHILE THE HINGE PIN IS RETRACTED, SLIDE THE DOOR INTO THE DOOR FRAME.

ALIGN HINGE PIN WITH THE HINGE PIN HOLE.

WHEN ALIGNED CORRECTLY, THE RETRACTED HINGE PIN WILL "SPRING UP" INTO POSITION.

THE DOOR IS NOW FULLY INSTALLED.

# #916 CLASSIC 16 GUN CABINET ASSEMBLY INSTRUCTIONS

**American**  
Furniture Classics

## STEP 12

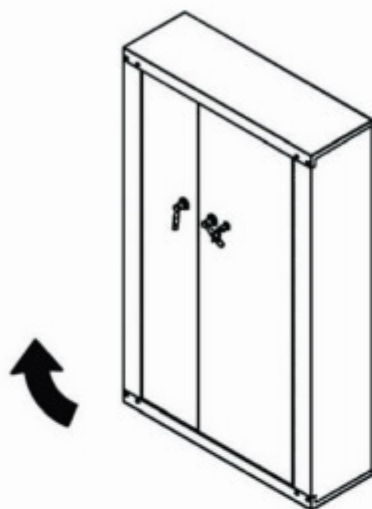

LIFT CABINET TO VERTICAL POSITION.

## STEP 13

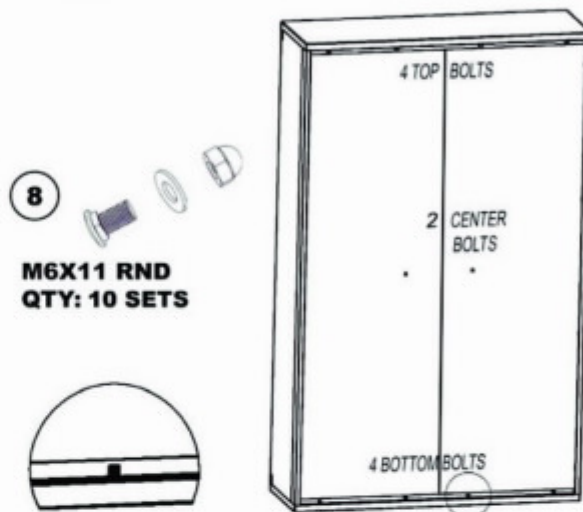

INSERT 10 - M6X11 RND BOLTS THROUGH BACK AND FULLY TIGHTEN WASHER & ROUND HEADED LOCK NUTS FROM INSIDE USING M6 WRENCH.

## STEP 14

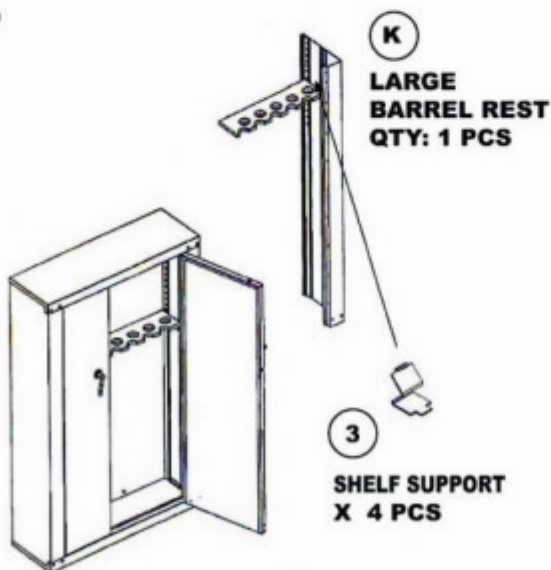

INSERT SHELF SUPPORTS INTO THE SLOTS ON THE LARGE RIGHT SIDE OF THE CABINET THEN LAY BARREL REST ON TOP OF THE SHELF SUPPORTS.

## STEP 15

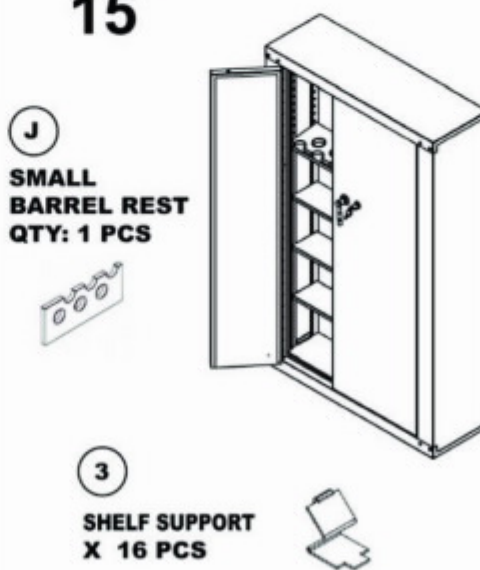

INSERT METAL STORAGE SHELVES OR SMALL BARREL REST ON THE SMALL LEFT SIDE OF THE CABINET USING SHELF SUPPORTS IN THE DESIRED LOCATION.

**NOTE**  
INSTALL EITHER  
SMALL BARREL  
REST OR  
ADJUSTABLE  
SHELVES AS  
DESIRED

# #916 CLASSIC 16 GUN CABINET ASSEMBLY INSTRUCTIONS

**American**  
Furniture Classics

## STEP 16

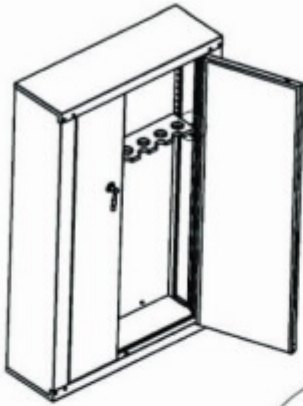

1

**SHELF LOCK**  
QTY: 20 PCS

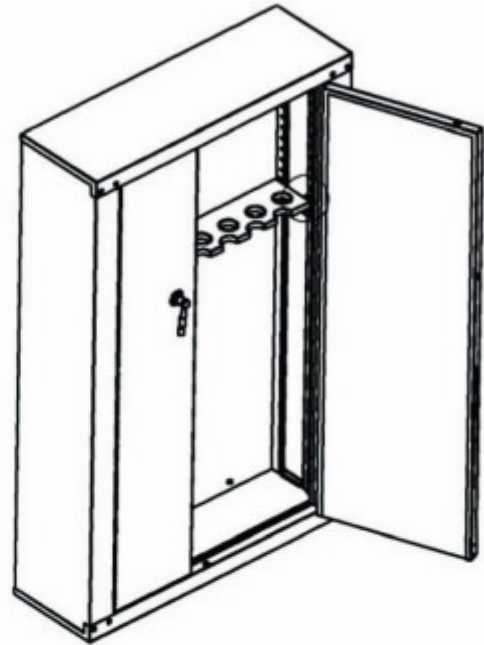
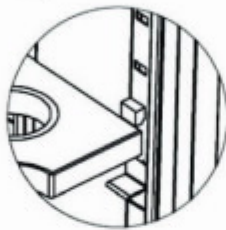

INSERT PLASTIC SAFETY CLIP ABOVE ALL SHELVES AND  
BARREL RESTS.

### Customer Service

• Toll Free 888-673-9080

• Fax 417-673-9081

• E-mail

[service@americanfurnitureclassics.com](mailto:service@americanfurnitureclassics.com)