

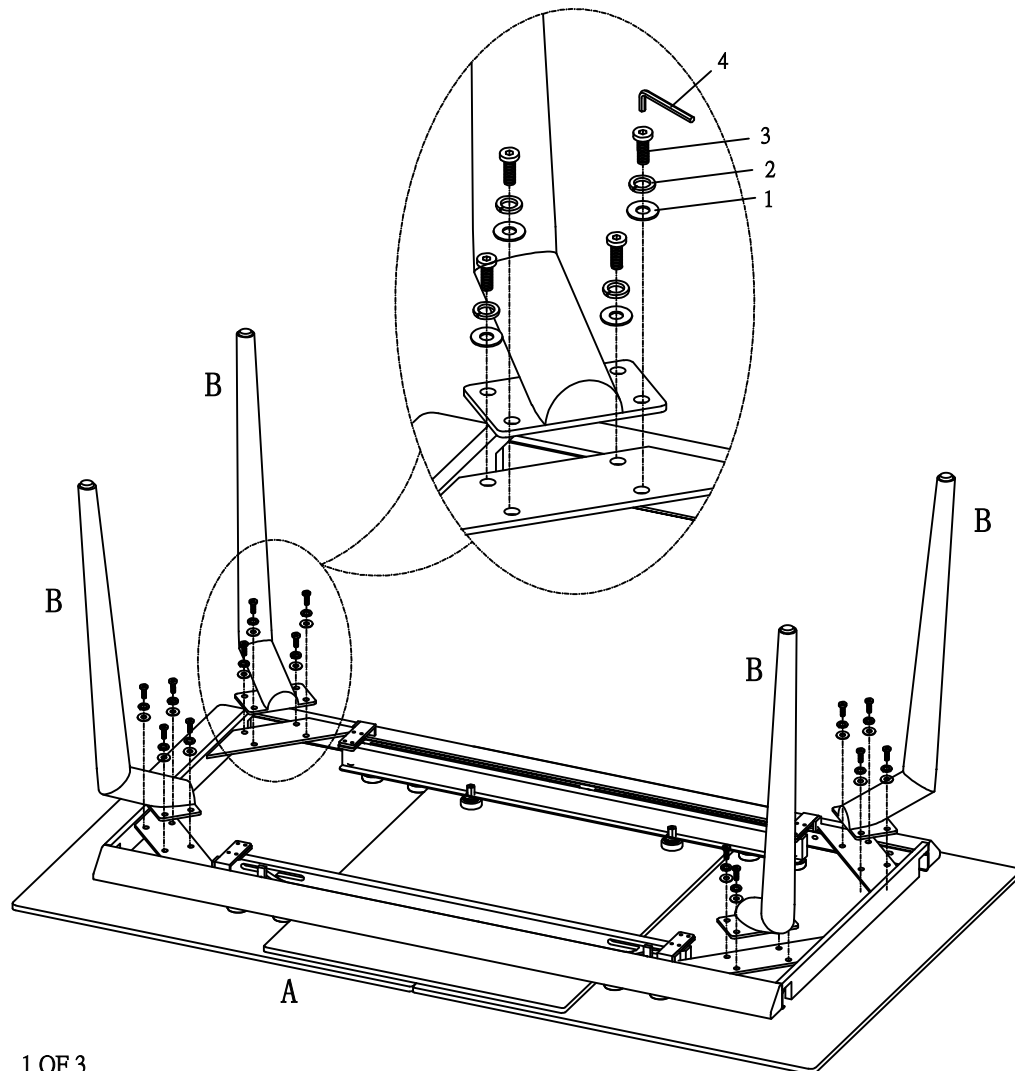

THANK YOU FOR PURCHASING THIS QUALITY PRODUCT.

BE SURE TO CHECK ALL PACKING MATERIAL CAREFULLY FOR SMALL PARTS THAT MAY HAVE COME LOOSE INSIDE THE CARTON DURING TRANSIT.

Step 1



PARTS LIST:

NO	DESCRIPTION	SIZE (mm)	SKETCH	QTY
A	TOP	900x1600		1PC
B	LEG	135x673		4PCS

HARDWARE LIST:

NO	DESCRIPTION	SIZE (mm)	SKETCH	QTY
1	WASHER	M8		16PCS
2	SPRING WASHER	M8		16PCS
3	BOLT	M8x15		16PCS
4	ALLEN KEY	5		1PC
5	ALLEN KEY	8		1PC



Step 2

Pay attention: Please hold the top frame when move the table, not just the glass top.

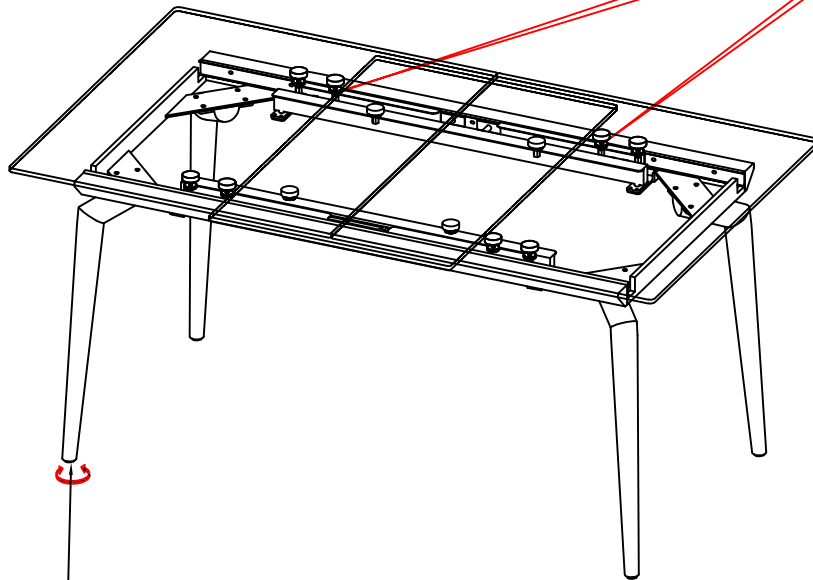

ADJUST THE GLIDES IF NEEDED

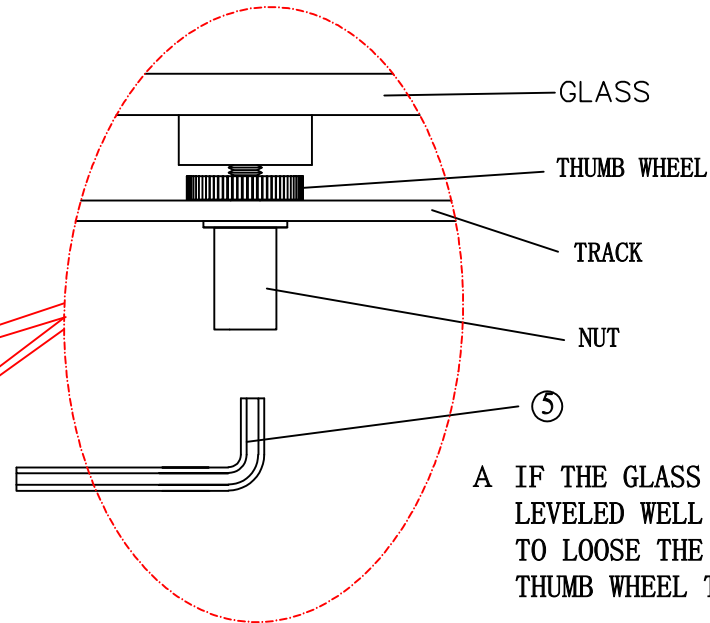

- A IF THE GLASS TOPS ARE NOT LEVELED WELL , PLEASE USE 5 TO LOOSE THE NUT, AND TURN THE THUMB WHEEL TO LEVEL THE TOPS.
- B IF THE GLASS TOPS ARE NOT ALIGNED WELL , PLEASE USE 5 TO LOOSE THE NUT, AND MOVE THE TOP A LITTLE BIT TO ALIGN THE TOPS.

Notice: Not to hold or raise the table from holding the top/extension together.

But need to hold the metal frame of the table to hold or raise the table to move to the locations preferred.

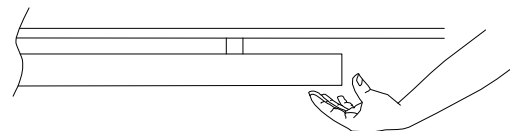

CORRECT WAY



FOLDED USE (1/2)

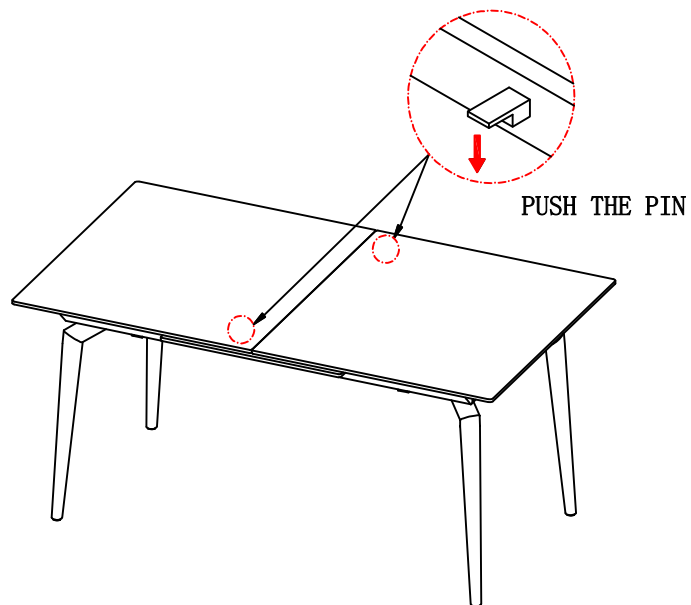

REMINDER:
WHEN YOU USE IT AS
A FOLDED SIZE,
PLEASE LOCK THESE 2
LOCKS

EXTENDED USE (2/2)

UNLOCK THE 2 LOCKS
BEFORE OPEN THE TOP

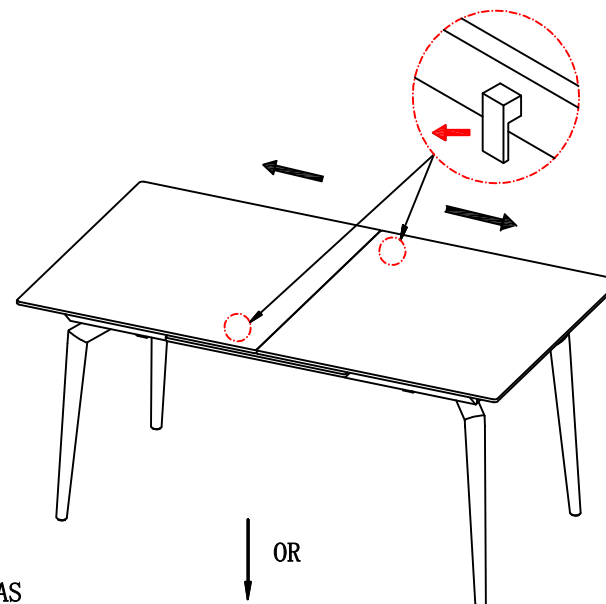

OR

REMINDER:
WHEN YOU USE IT AS
A FOLDED SIZE,
PLEASE LOCK THESE 2
LOCKS

