

# Assembly Instructions

4902960T Del Mar 61" - Double Vanity Top  
4902960B Del Mar 61" - Double Vanity Base

**Product Issues? Please Call Us Before Contacting Your Retailer At  
1-800-549-3300, email [customerservice@mshome.co](mailto:customerservice@mshome.co), or visit [www.mshome.co](http://www.mshome.co)  
We can help with Assembly Issues, Part Requests, Damages, & All Other  
Product Related Questions**

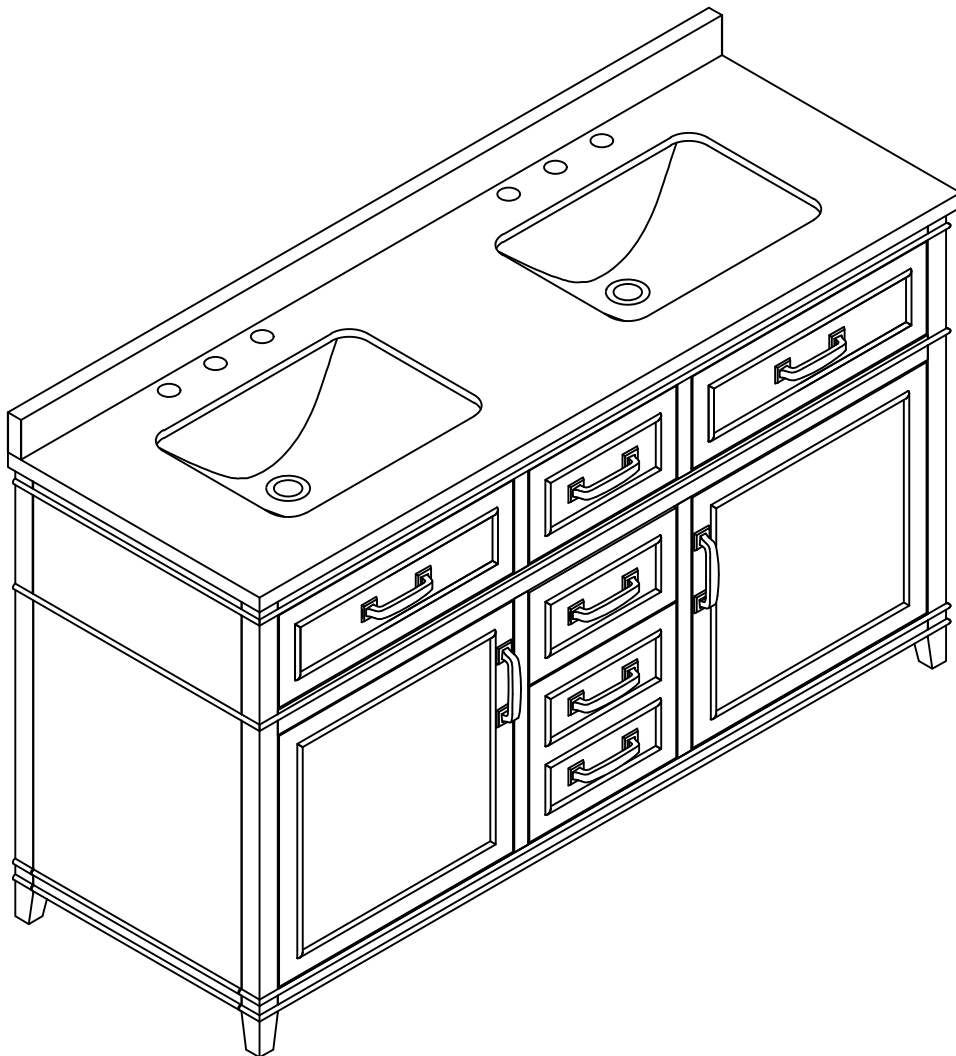

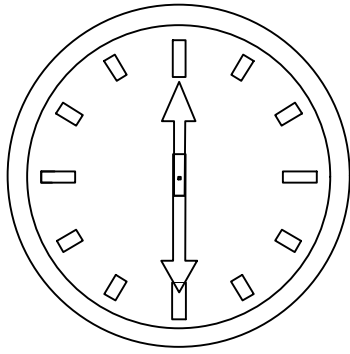

30 min

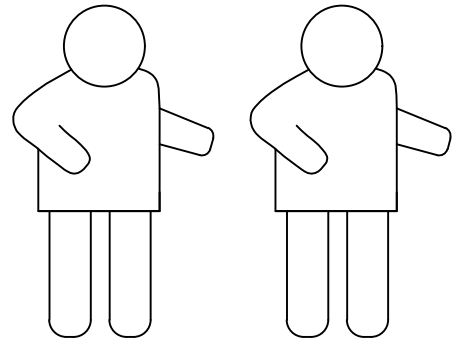

Two People Required

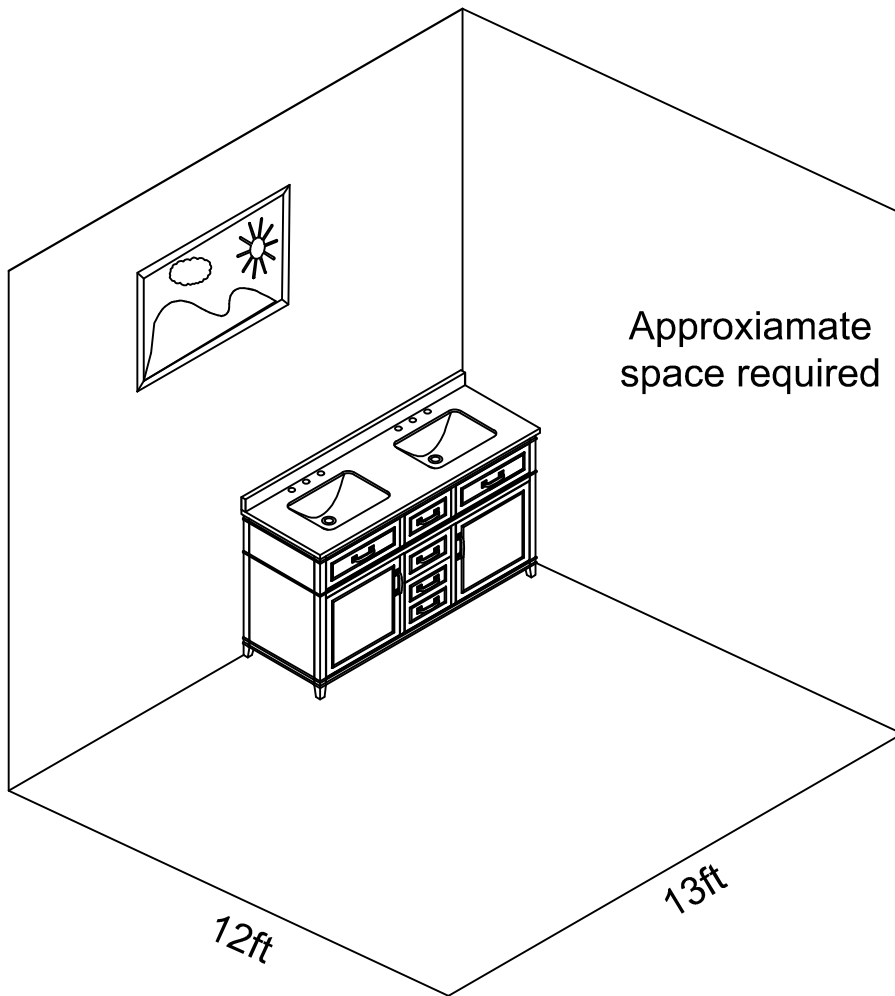

Phillips Head  
Not Provided



# IMPORTANT



## Assembly and installation guide:

- Carefully read all of the instructions before starting the assembly and installation process. Failure to do so may lead to injury, damage to the product, or other property damage.
- This vanity should be installed by an experienced plumber
- **Two people** are required to assemble this vanity
- Drain pipe and drain trap are not supplied. Connect to an existing drain pipe.
- Assemble in or near final installation position
- Do not drag the vanity as it may damage the product.
- Warning the top is VERY HEAVY and FRAGILE, use extreme caution while handling and moving.

## Dimensions:

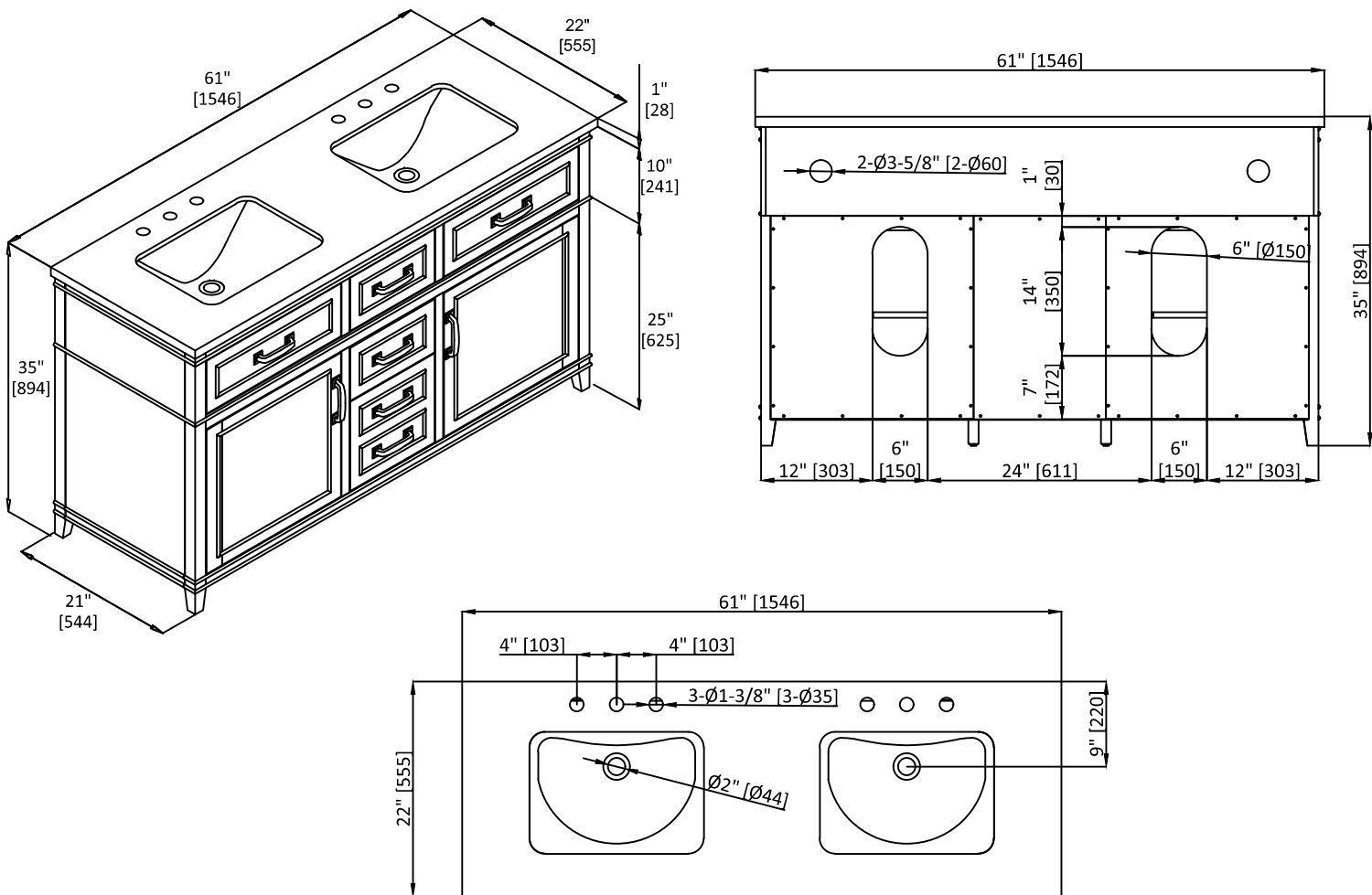

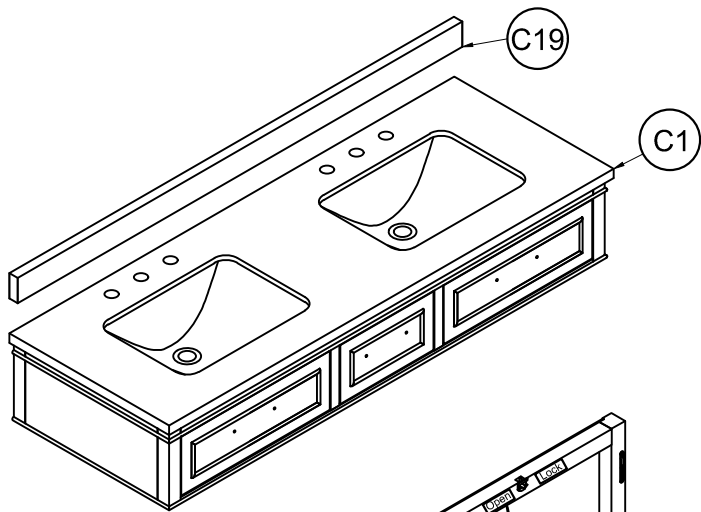

**Part List : 4902960T**



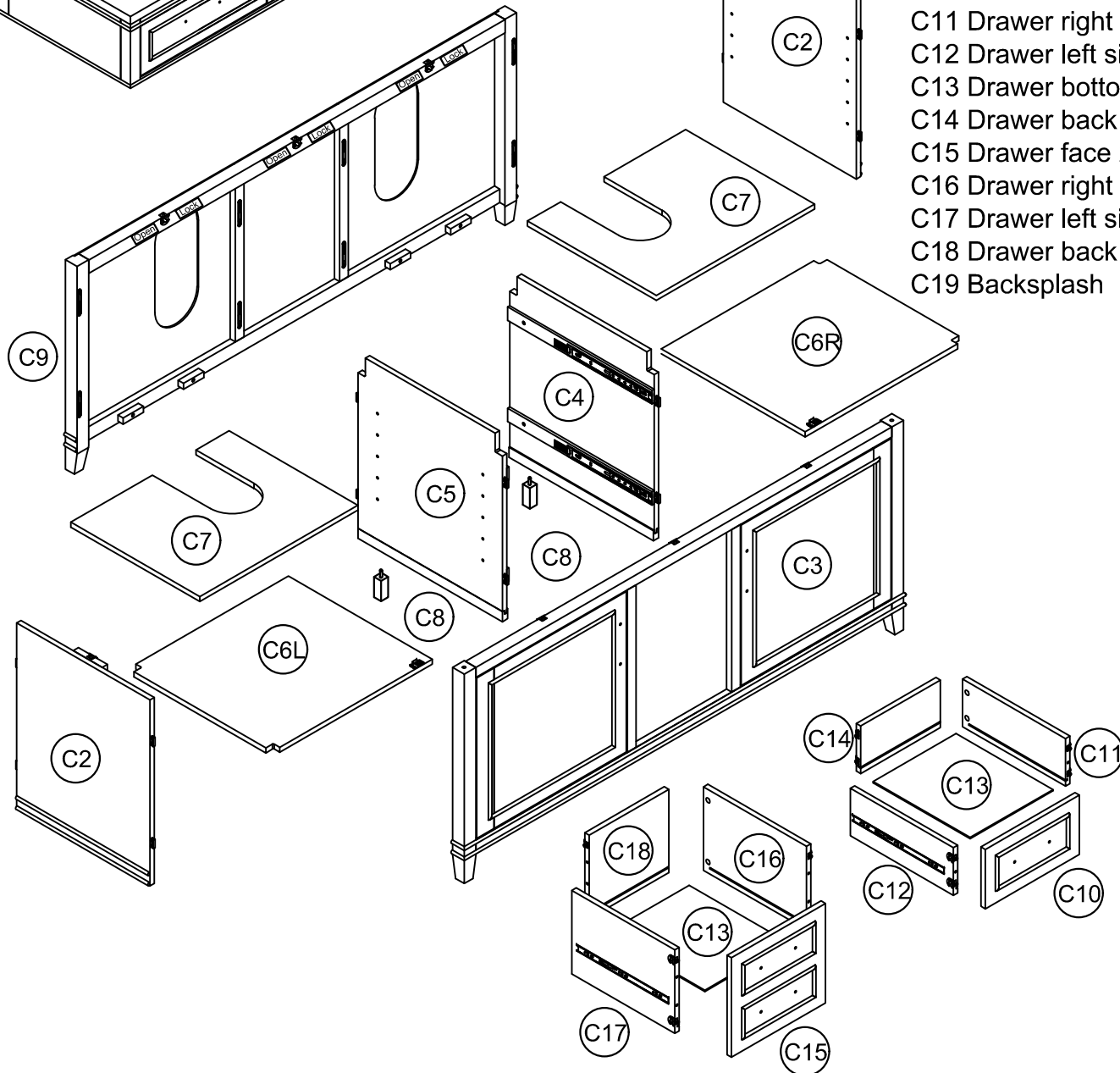

C1 Top

**Part List : 4902960B**

- C2 Side panel x2
- C3 Front frame
- C4 Partition right panel
- C5 Partition left panel
- C6L Left bottom panel
- C6R Right bottom panel
- C7 Shelf panel x2
- C8 Support leg x2
- C9 Back panel
- C10 Drawer face 1
- C11 Drawer right side panel 1
- C12 Drawer left side panel 1
- C13 Drawer bottom panel x2
- C14 Drawer back panel 1
- C15 Drawer face 2
- C16 Drawer right side panel 2
- C17 Drawer left side panel 2
- C18 Drawer back panel 2
- C19 Backsplash

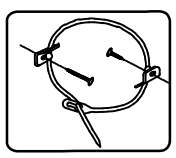

**Hardware Pack located in carton 4902960B**

<p>A</p>  <p>∅8x30 (mm) 2 pcs</p>	<p>B</p>  <p>8 pcs</p>	<p>C</p>  <p>∅3.5x15 (mm) 8 pcs</p>	<p>D</p>  <p>8 pcs</p>	<p>E</p>  <p>∅4x25 (mm) 16 pcs</p>	 <p>ANTI-TIP SET</p>
--	---	--	---	---	---

1

Dx3

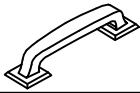

E x6



Ø4x25 (mm)



Please lay all components on smooth flat surface to prevent scratches. Use the EPE foam to protect the plastic hardware before assembly

Make sure all 8 latches are in the locked position

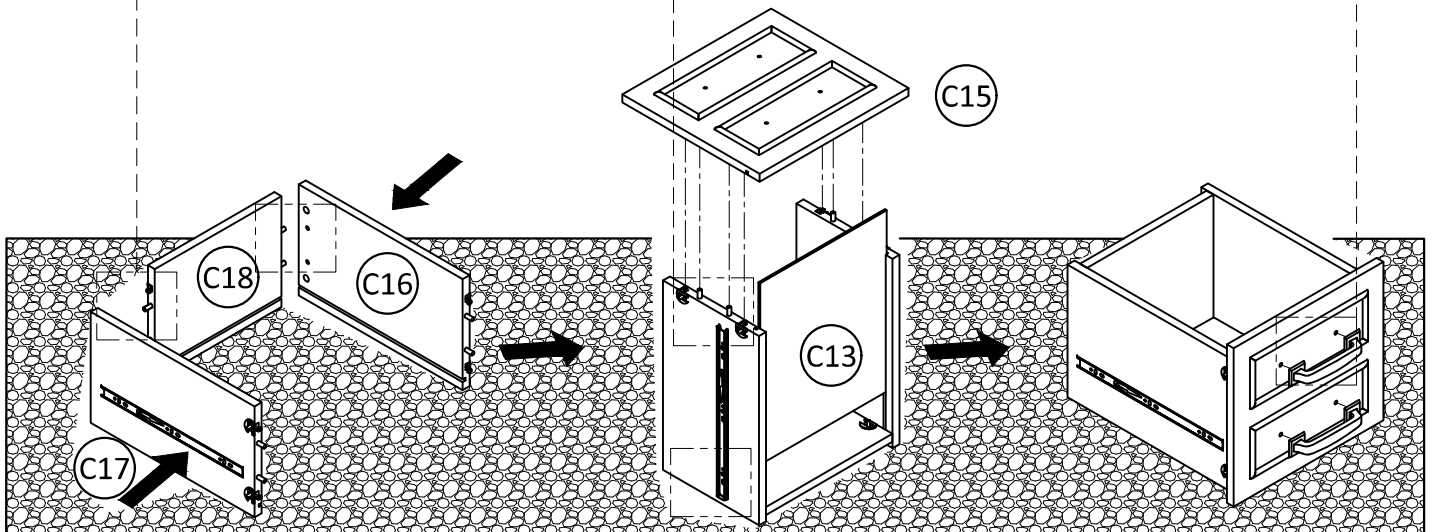
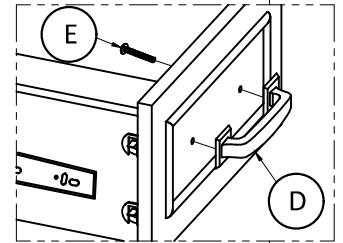
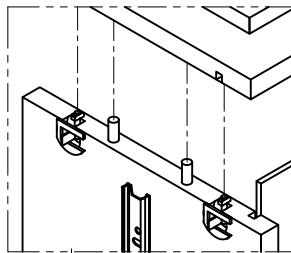
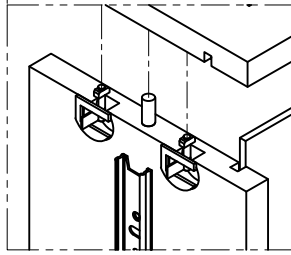
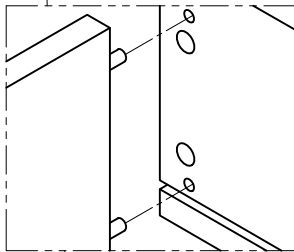
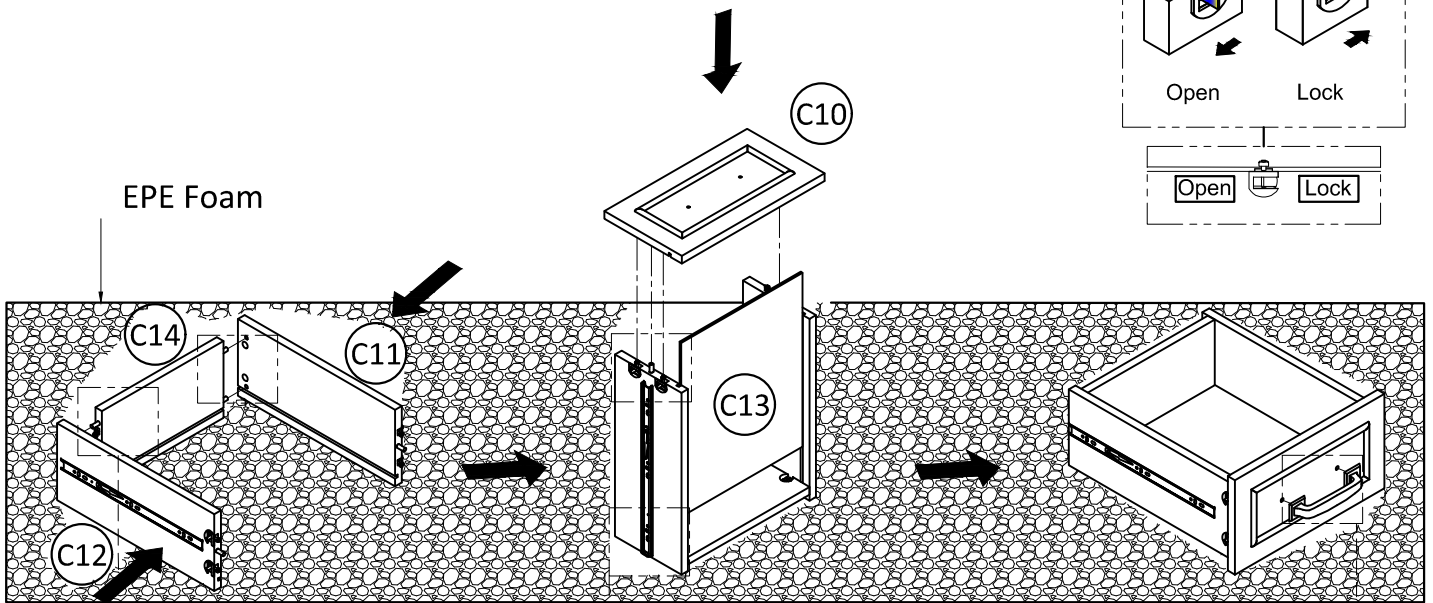
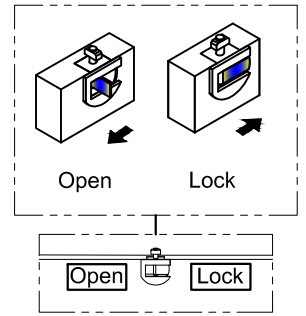

2

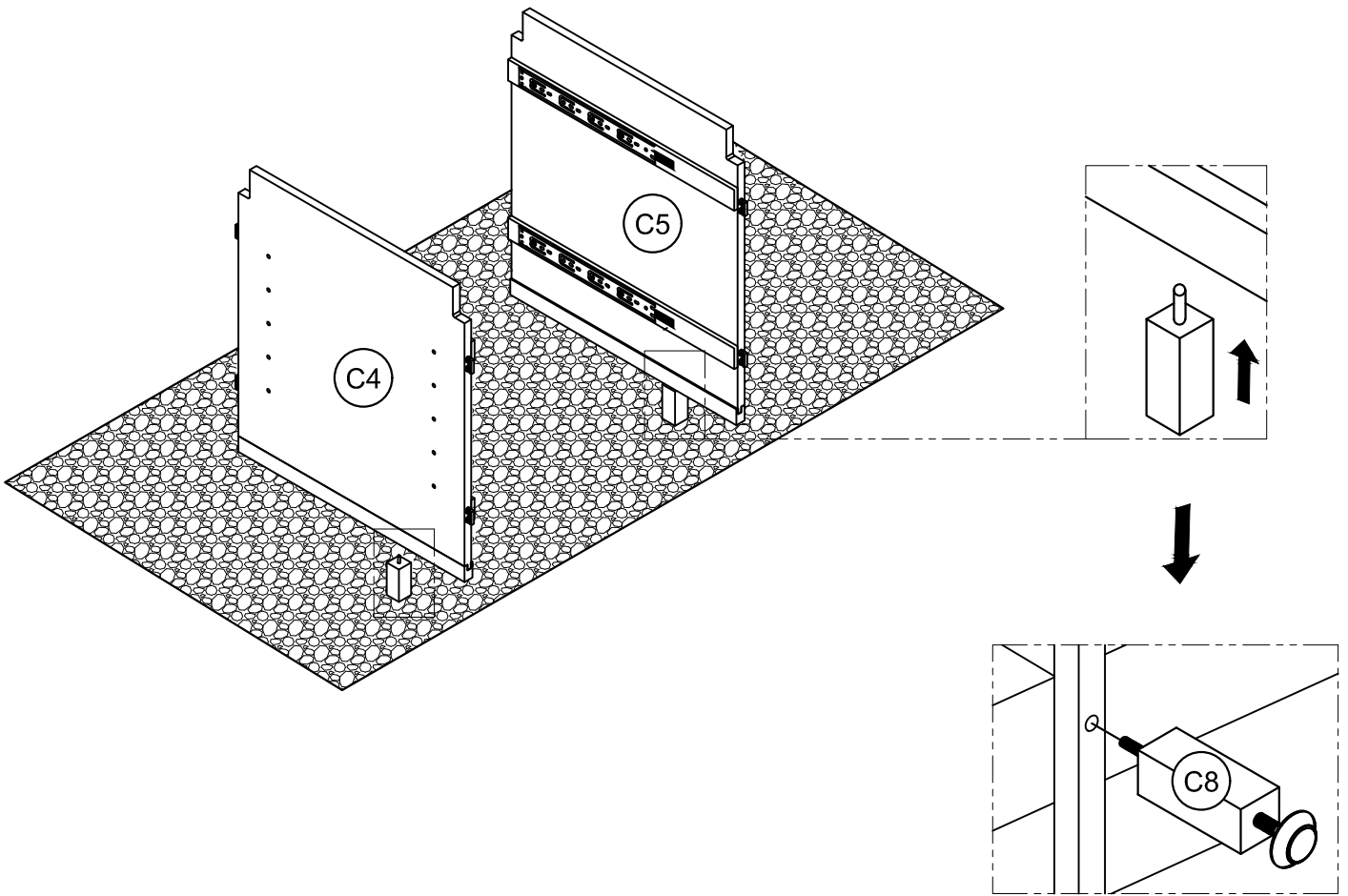

3

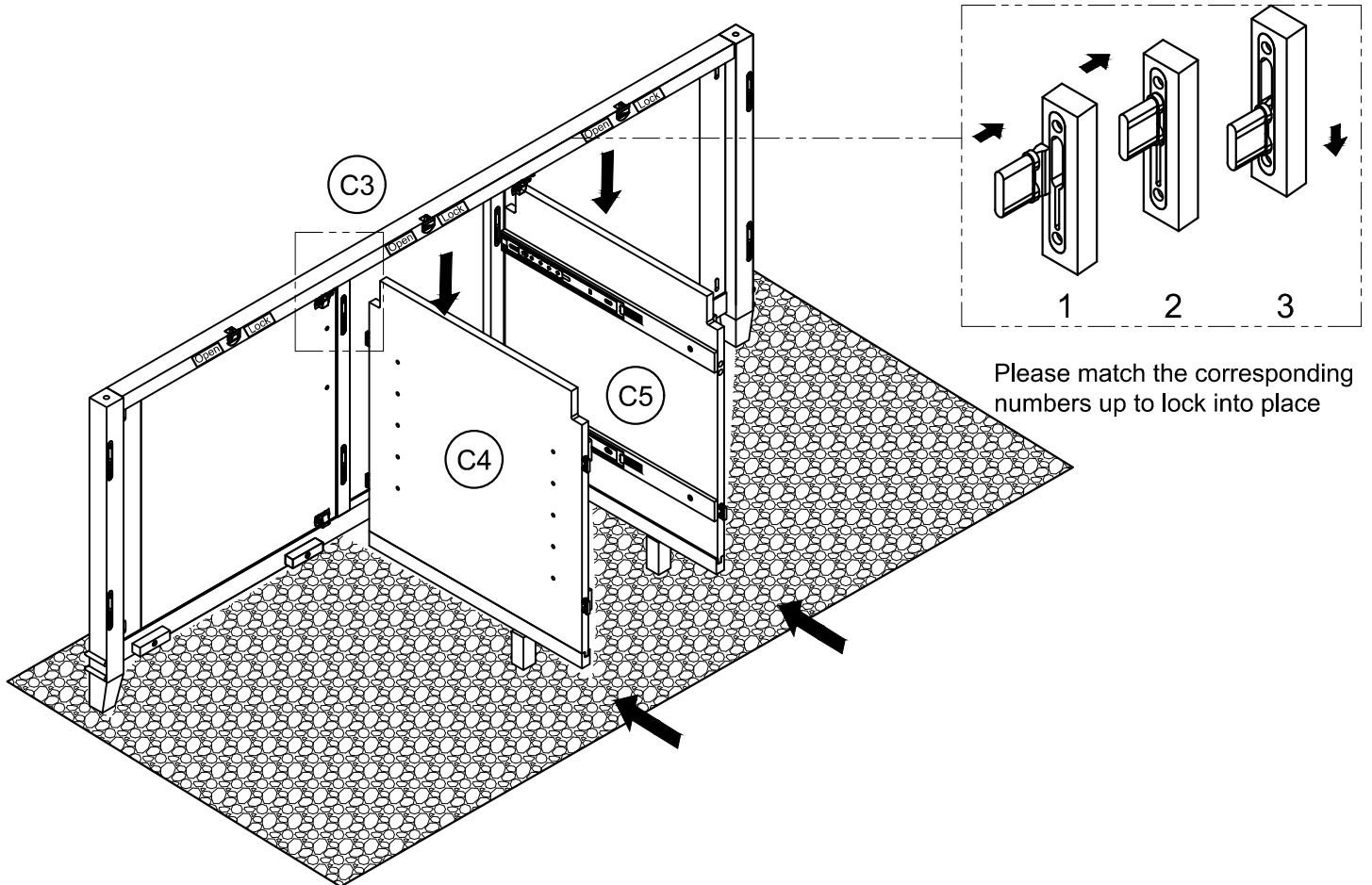

4

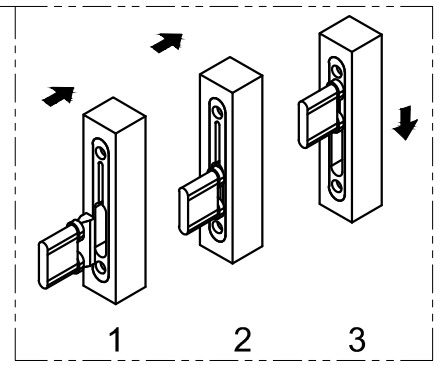
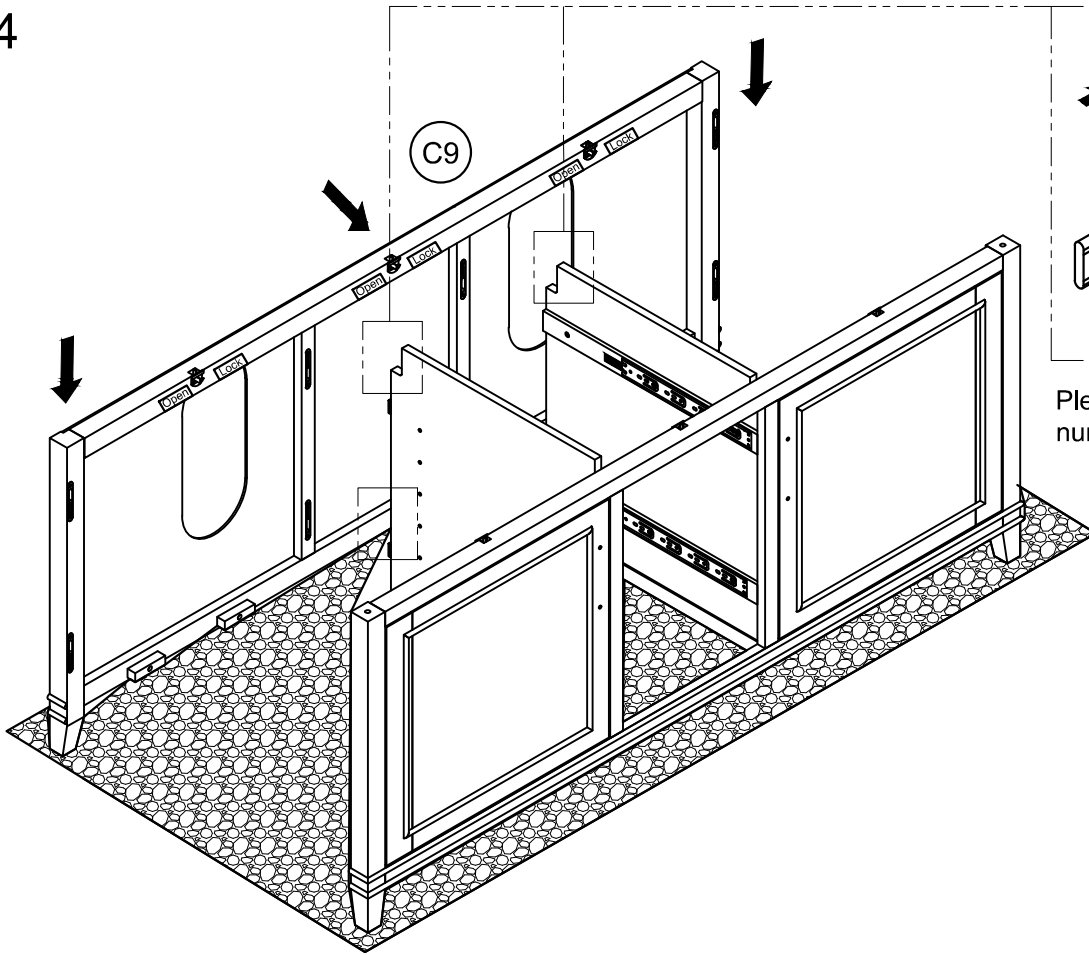

Please match the corresponding numbers up to lock into place

5

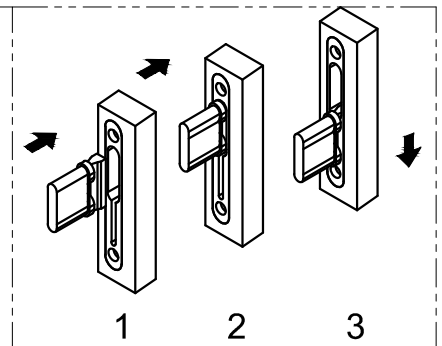
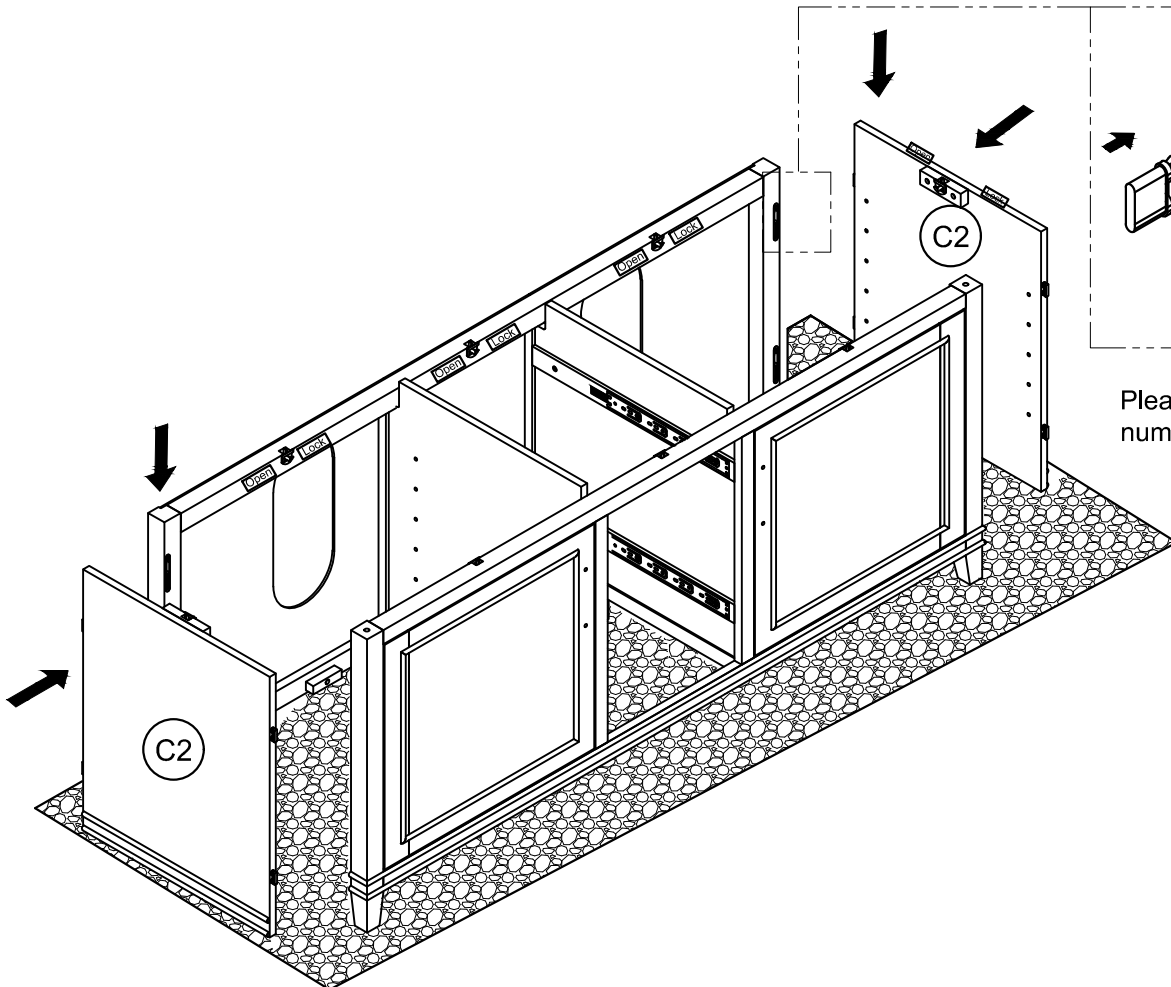

Please match the corresponding numbers up to lock into place

6

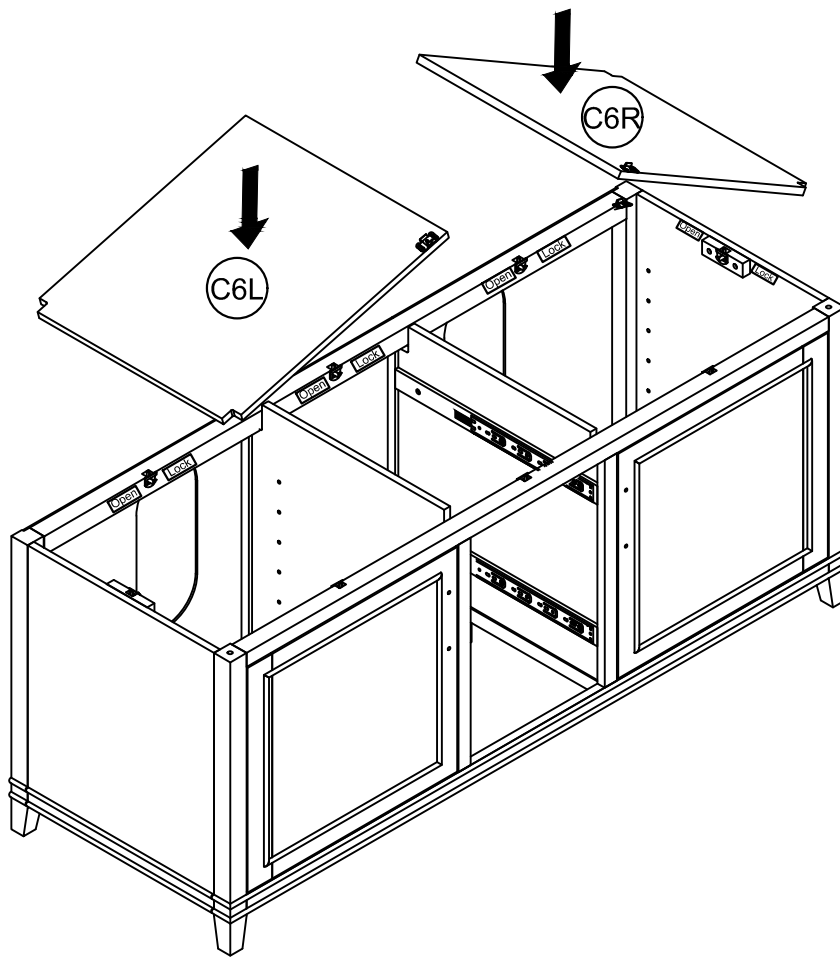

7

Make sure all latches are in the open position before installing Top Panel (C1)

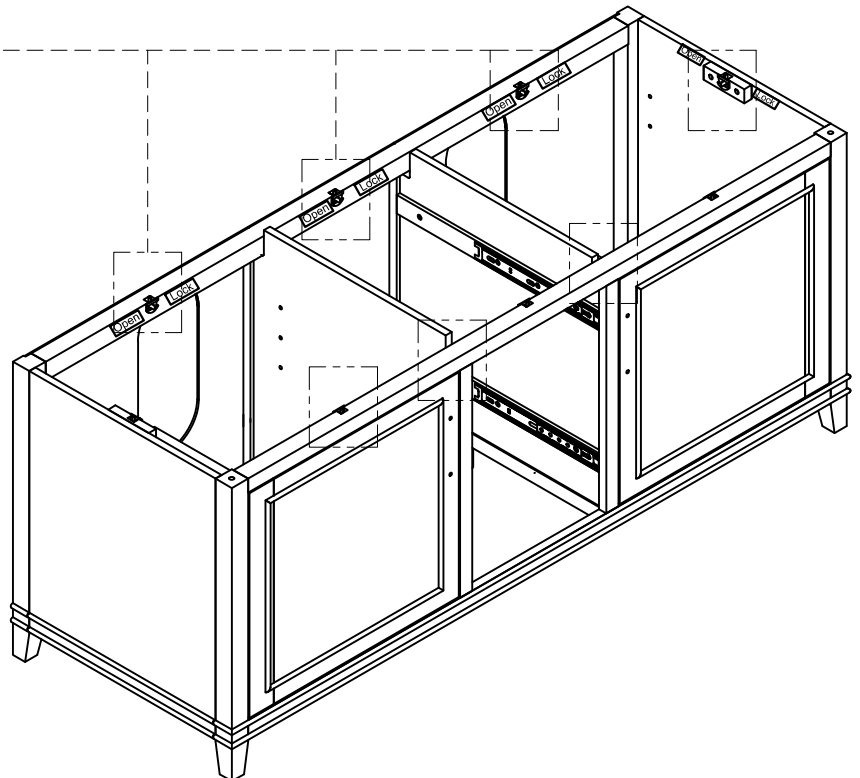
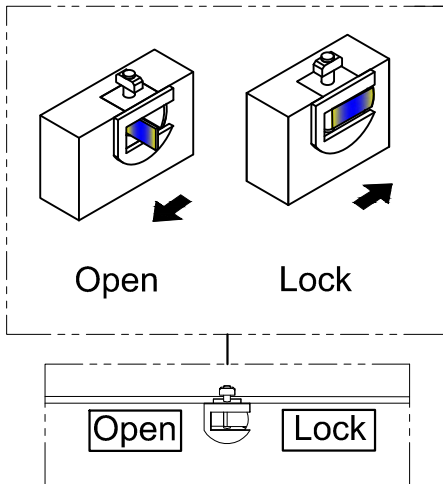

8

Ax2



Ø8x30 (mm)

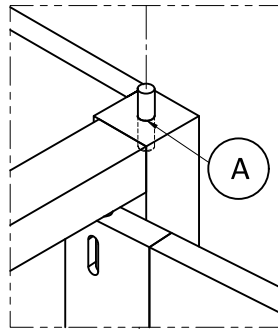

Carefully place the Top - C1 down to avoid damage.

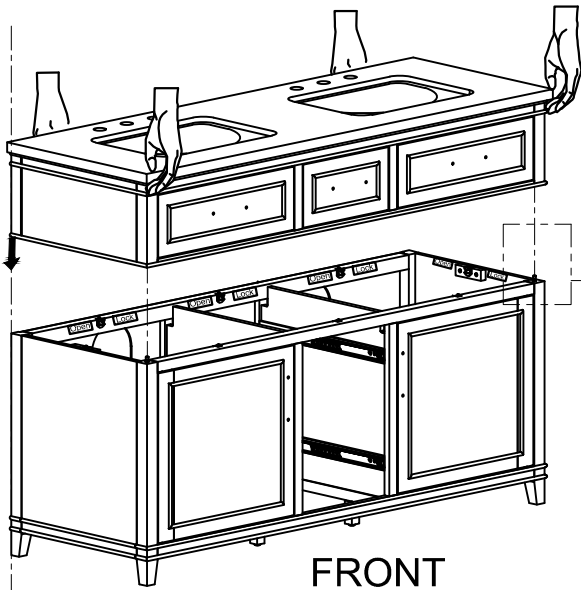

FRONT

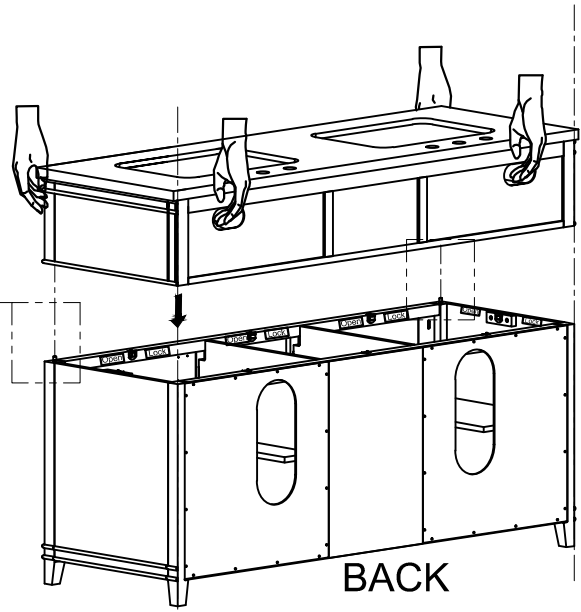

BACK

Warning - This step requires two people to place the top on the base.  
Failure to do so may result in damage or injury.

9

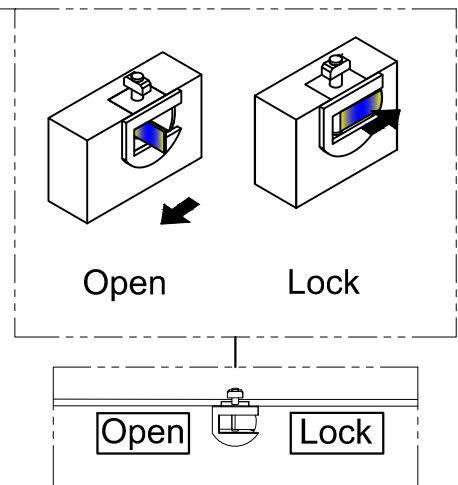
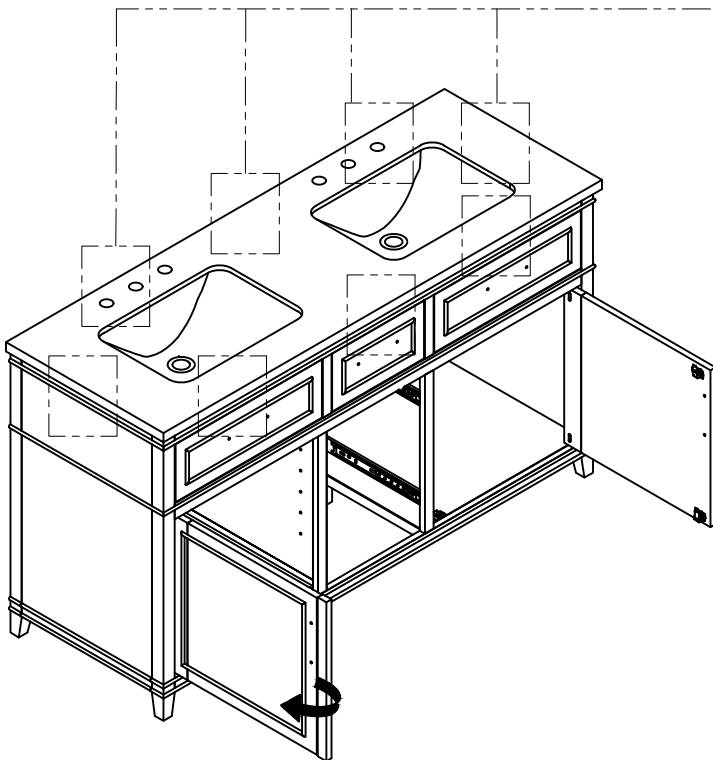

Make sure all 8 latches are in the locked position

10

Bx8



Cx8



Ø3.5x15 (mm)

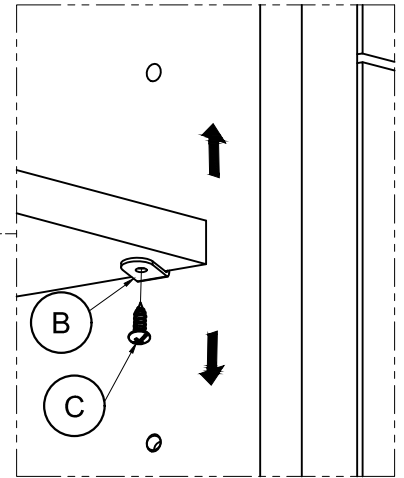
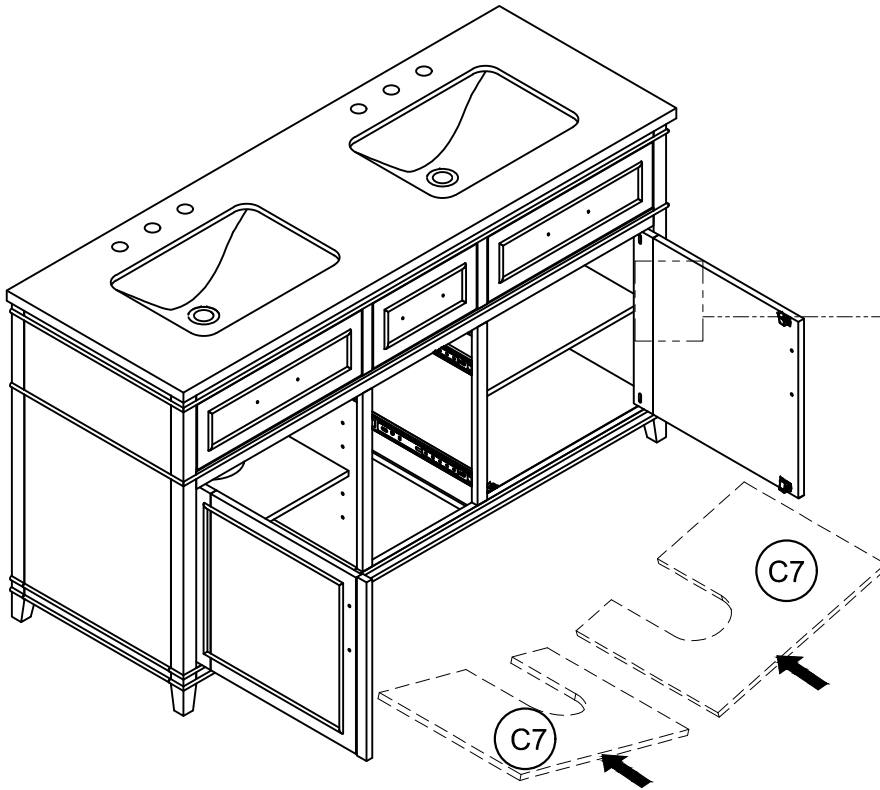
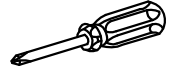

Ensure that side rail support is positioned under wood molding

11

Dx5

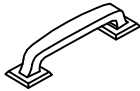

Ex10



Ø4x25 (mm)

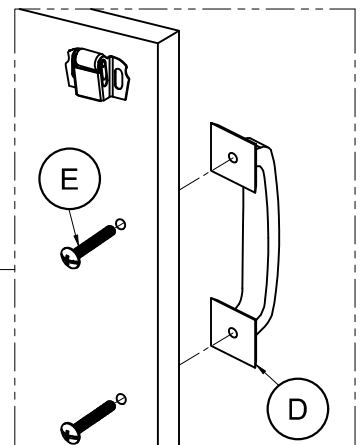
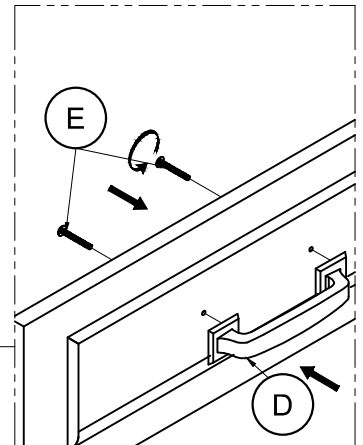
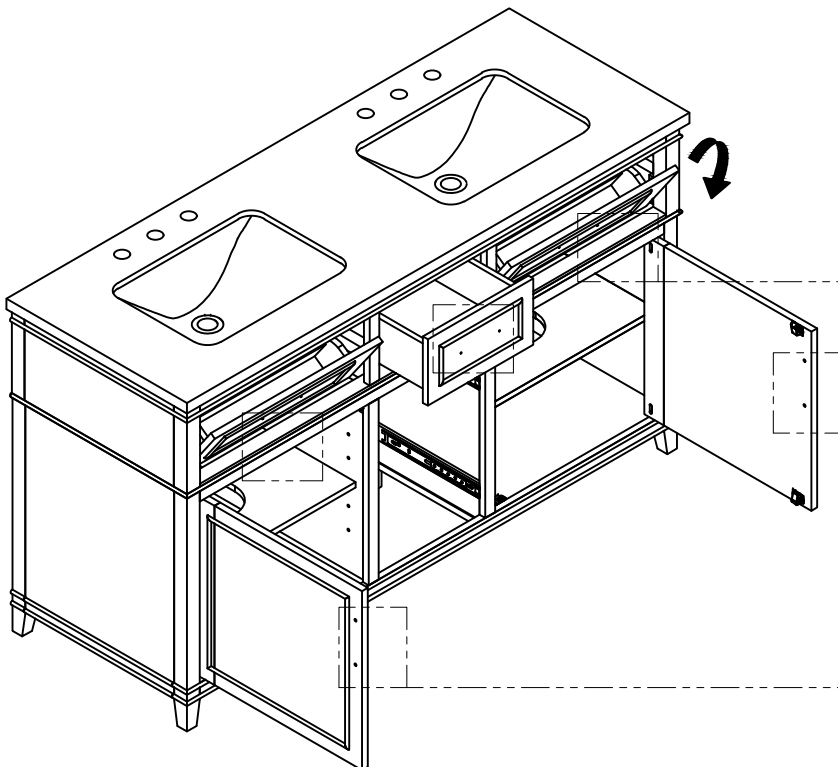
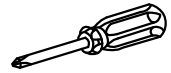

10-12

Line up the drawer guides and push drawer back into place.

Push up or down on each side of the drawer and hold.

Pull back and the drawer should unlock and slide out.

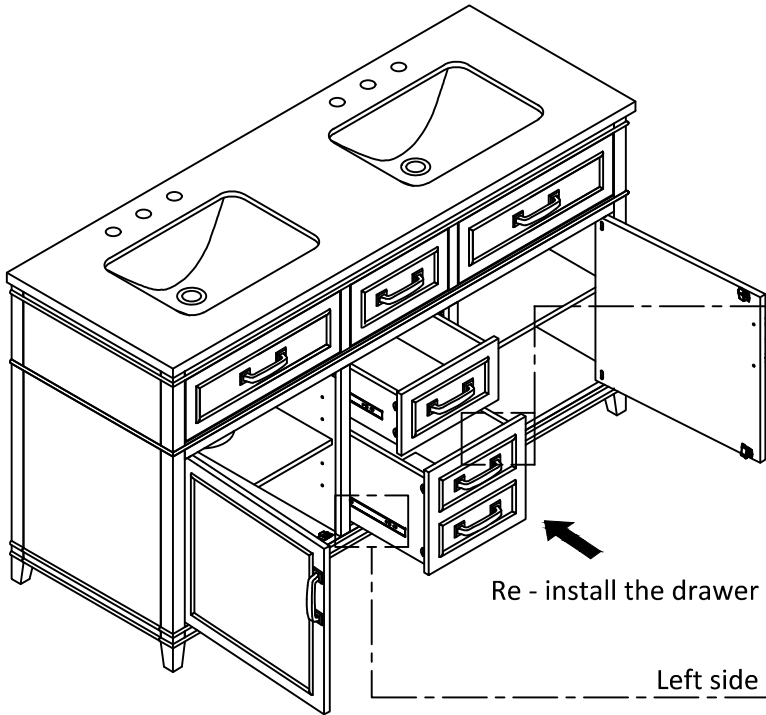

Push down on the tab and hold

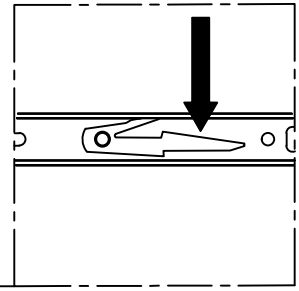

Push up on the tab and hold

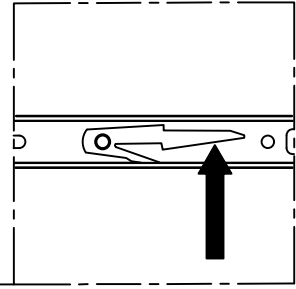

12

Following tools are required(not supplied)

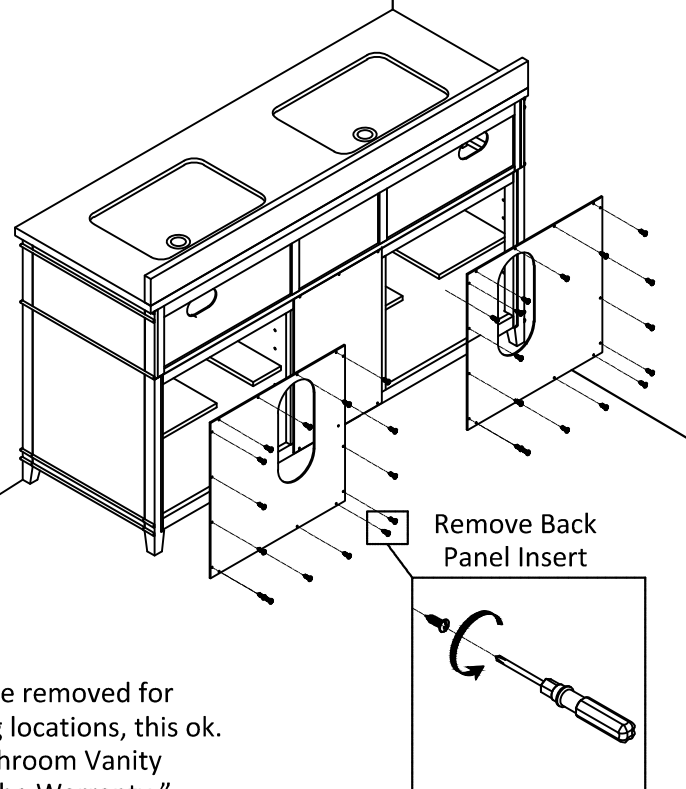
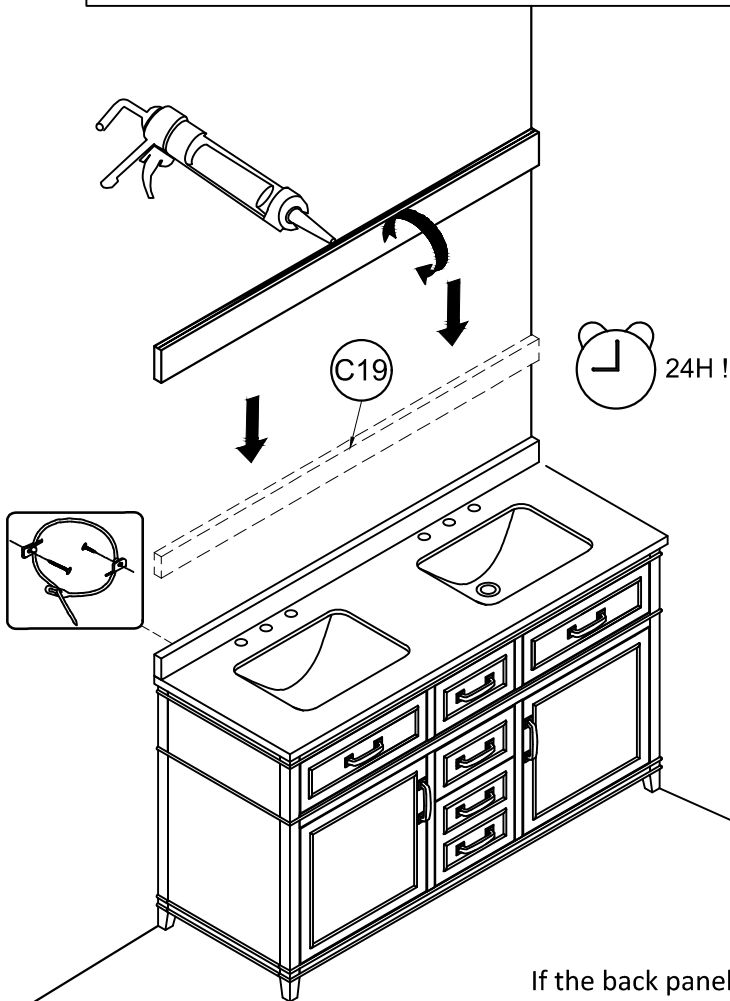

If the back panel needs to be removed for installation for piping/plumbing locations, this ok.  
This will not affect the Bathroom Vanity structure & will not affect the Warranty."

## MARTIN SVENSSON HOME LIMITED WARRANTY

EXCEPT AS EXPRESSLY STATED BELOW, OUR PRODUCTS ARE "AS IS" WITHOUT WARRANTY OF ANY KIND, EITHER EXPRESS OR IMPLIED, INCLUDING, WITHOUT LIMITATION, ANY WARRANTIES OF MERCHANTABILITY OR FITNESS FOR A PARTICULAR PURPOSE. BECAUSE SOME JURISDICTIONS DO NOT PERMIT THE EXCLUSION OF IMPLIED WARRANTIES, THIS DISCLAIMER MAY NOT APPLY.

We strive to produce defect-free furniture. Our products are warranted for one (1) year from date of purchase against defects. **"Manufacturing Defects"** are described as:

- Missing drawer pulls or missing hardware required for assembly
- Drawers that are inoperable or that fail to open and close easily
- Screws or staples penetrating outer faces of product

Martin Svensson does not provide warranty protection against "damages resulting from inappropriate handling of the product by the customer, in-store, in-warehouse, or during transportation. **"Damages Resulting from Inappropriate Handling"** are described as:

- Crushed corners of top
- Separation of tops from their cases due to lifting the item by their tops
- Damage caused by failure to follow assembly instructions
- Blown out or punctured case-backs
- Rub marks on the wood surfaces, usually caused by improper handling

Most damages are caused by mishandling of furniture while it is still in the box. Care should be taken that products be stored with "arrows up" and not be "dragged across the floor" once they are assembled and are out-of-their cartons in the warehouse, in the store, or in the homes of consumers.

There are some "naturally occurring imperfections" associated with our type of product and manufacturing process that cannot be avoided, and therefore, must be accepted by our customers. **"Naturally Occurring Imperfections"** are described as:

- Limited number of small nail holes in decorative moldings
- Small spaces not fully covered at the edges and corners of the item and/or its tops