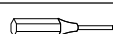
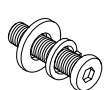

ASSEMBLY INSTRUCTIONS

DRESSER 2477-40 & MIRROR 2477-50

Caution: Please read instructions thoroughly before unpacking assembly parts. Sharp exposed staple tips can cause injury, therefore, for your protection, please remove any exposed staples used in packing.

- 1-We recommend that you should assemble this product with the assistance of another person; this will make assembly easier, and will help to eliminate damage to the product or injury or persons during assembly.
- 2-Be sure to check all packing materials carefully for small parts that may have come loose inside the carton during shipment.
- 3-Please do not over tighten screw or bolts.
- 4-Please put all parts on a non-abrasive floor before assembly, and follow the assembly steps to assemble your newly purchased product correctly and efficiently.

Code	Parts List For Dresser 2477-40	Qty	Code	Hardware List For Dresser 2477-40	Qty		
Ⓐ	Dresser	1pc	①	Tipping Restraint		1pc	
			TOOLS REQUIRED (NOT PROVIDED)				
			Screwdriver				
Code	Parts List for Mirror 2477-50	Qty	Code	Hardware Mirror 2477-50	Qty		
Ⓑ	Mirror	1pc	②	JCBC Bolt (Ø1/4" x 38mm)		8pcs	
				Spring washer (Ø1/4"x13x1.2)		8pcs	
				Flat washer (Ø1/4"x19x1)		8pcs	
Ⓒ	Mirror Support	2pcs	③	Allen Key (L60*4mm)	1pc		

STEP 1

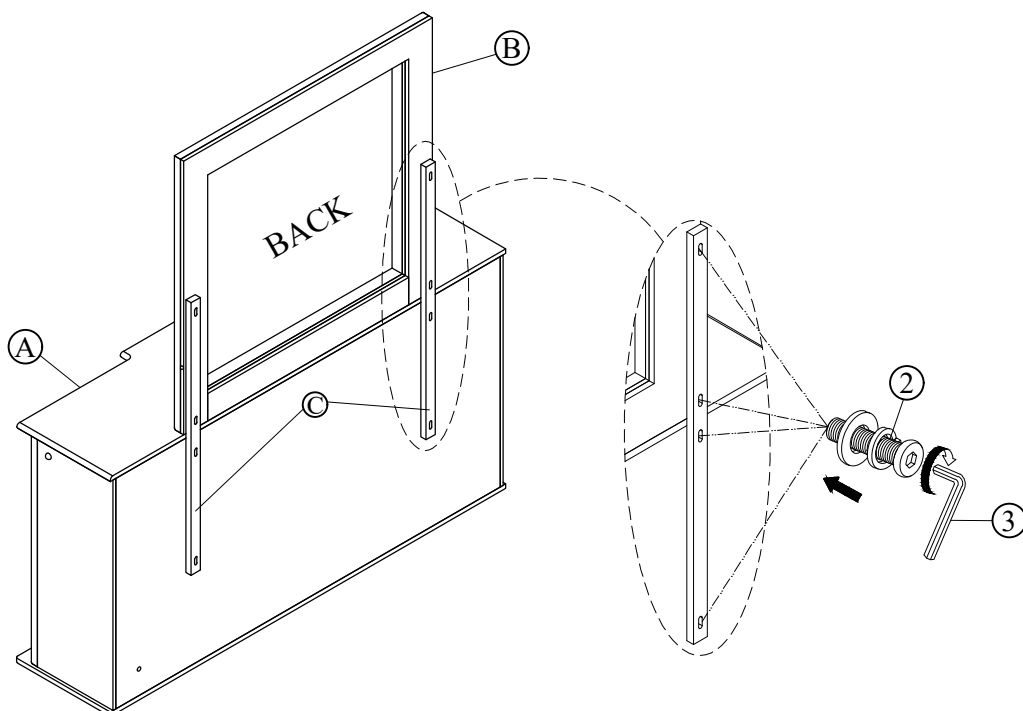

STEP 2

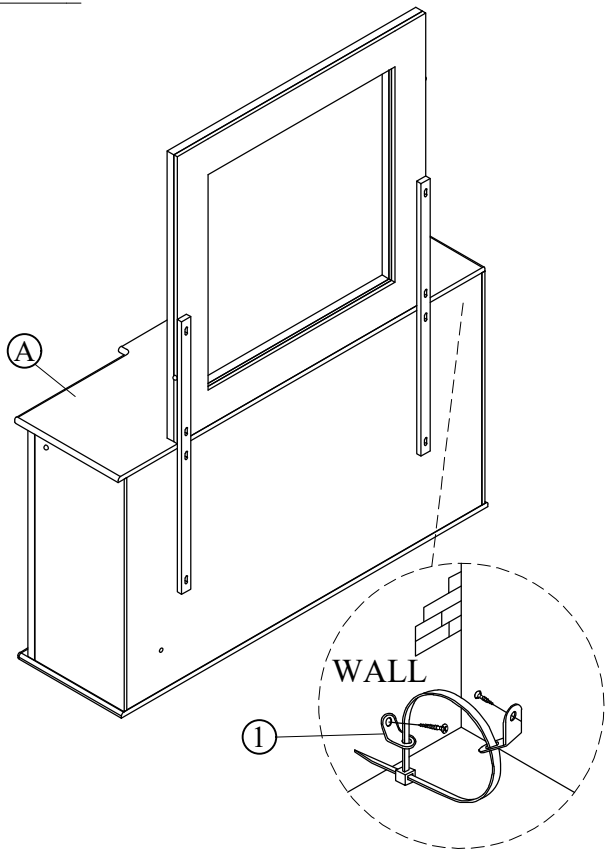

STEP 3

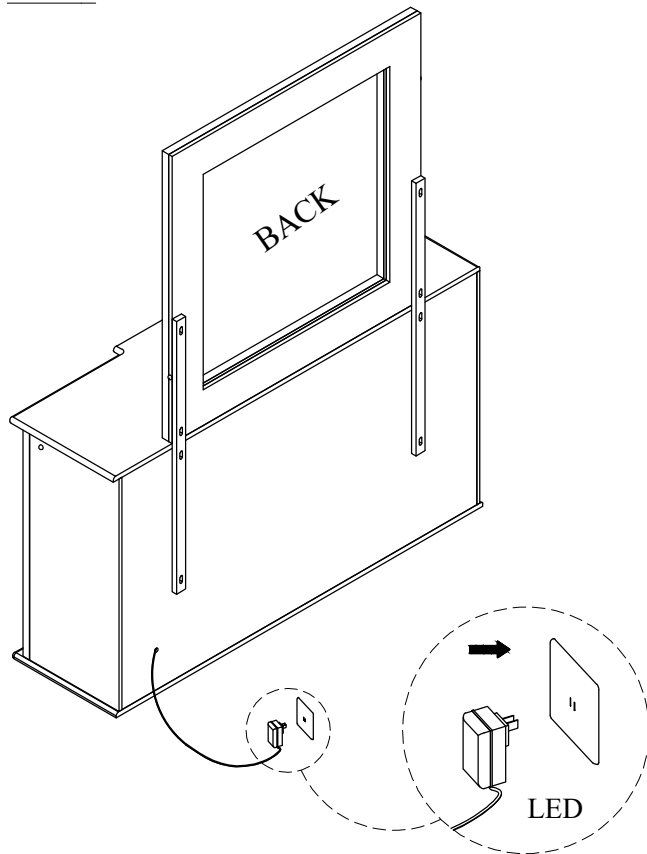

REMARK: there is a tip restraint kit provided on the back of this product. please read the directions thoroughly and install immediately when placed in home

COMPLETE

