

ASSEMBLY INSTRUCTIONS

NIGHTSTAND



F1750

Caution: Please read instructions thoroughly before unpacking assembly parts. Sharp, exposed staple tips can cause injury, therefore, for your protection, please remove any exposed staple used in packing.

1. We recommend that you should assemble this product with the assistance of another person; this will make assembly easier, and will help to eliminate damage to the product or injury to persons during assembly.
2. Be sure to check all packing materials carefully for small parts that may have come loose inside the carton during shipment.
3. please do not over tighten screws or bolts.
4. Please put all parts on a non-abrasive floor before assembly, and follow the assembly steps to assemble your newly purchased product correctly and efficiently.



PART LISTS

NO.	DESCRIPTION	SKETCH	QTY
(1)	BASE		1PC
(2)	TIPPING RESTRAINT		1PC

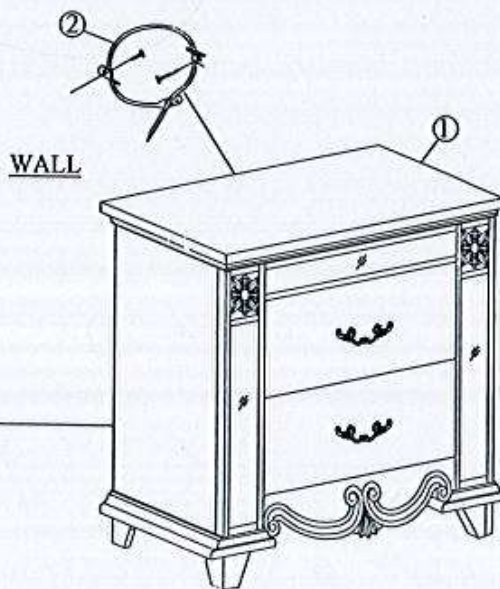

ASSEMBLY INSTRUCTIONS



CHEST

Caution: Please read instructions thoroughly before unpacking assembly parts. Sharp, exposed staple tips can cause injury, therefore, for your protection, please remove any exposed staple used in packing.

1. We recommend that you should assemble this product with the assistance of another person; this will make assembly easier, and will help to eliminate damage to the product or injury to persons during assembly.
2. Be sure to check all packing materials carefully for small parts that may have come loose inside the carton during shipment.
3. please do not over tighten screws or bolts.
4. Please put all parts on a non-abrasive floor before assembly, and follow the assembly steps to assemble your newly purchased product correctly and efficiently.



PART LISTS

NO.	DESCRIPTION	SKETCH	QTY
(1)	BASE		1PC
(2)	TIPPING RESTRAINT		1PC

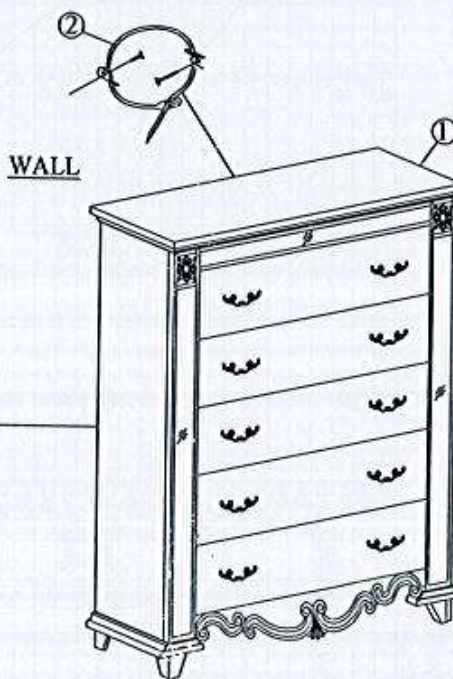







ASSEMBLY INSTRUCTIONS

DRESSER&MIRROR

Caution: Please read instructions thoroughly before unpacking assembly parts. Sharp, exposed staple tips can cause injury, therefore, for your protection, please remove any exposed staple used in packing.

1. We recommend that you should assemble this product with the assistance of another person; this will make assembly easier, and will help to eliminate damage to the product or injury to persons during assembly.
2. Be sure to check all packing materials carefully for small parts that may have come loose inside the carton during shipment.
3. please do not over tighten screws or bolts.
4. Please put all parts on a non-abrasive floor before assembly, and follow the assembly steps to assemble your newly purchased product correctly and efficiently.



HARDWARE LISTS				PART LISTS			
NO:	COMPONENT		Q'TY	NO.	DESCRIPTION	SKETCH	QTY
A	JCBC Bolt 5/16" *1-1/2"L		8	(1)	BASE		1PC
B	Spring Washer 5/16" Dia		8	(2)	TIPPING RESTRAINT		1PC
C	Flat Washer 5/16" Dia		8	(3)	MIRROR		1PC
D	Allen Key		1	(4)	MIRROR SUPPORT		2PCS

STEP 1

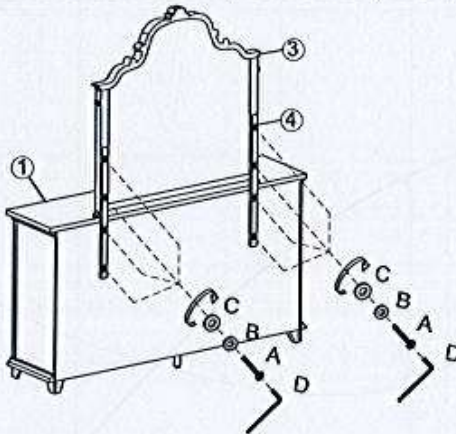

STEP 2



WALL



WALL









Completed



ASSEMBLY INSTRUCTIONS





QUEEN BED

Caution: Please read instructions thoroughly before unpacking assembly parts. Sharp, exposed staple tips can cause injury, therefore, for your protection, please remove any exposed staple used in packing.

1. We recommend that you should assemble this product with the assistance of another person; this will make assembly easier, and will help to eliminate damage to the product or injury to persons during assembly.
2. Be sure to check all packing materials carefully for small parts that may have come loose inside the carton during shipment.
3. please do not over tighten screws or bolts.
4. Please put all parts on a non-abrasive floor before assembly, and follow the assembly steps to assemble your newly purchased product correctly and efficiently.

No.	Parts List		Q'Ty
A		Headboard Panel	1PC
B		L/R Posts	2 pieces
C		Footboard	1PC
D		Side Rail	2 pieces
E		Bed Slat	4 pieces
F		Slat Support Leg	4 pieces

Hardware List for Headboard			
1		Allen Key (L57*4mm)	1PC
2		JCBC Bolt 5/16" * 1.5"L	8 Pieces
		Spring Washer (Ø5/16" * 13 *1.2)	8 Pieces
		Flat Washer (Ø5/16" *18 * 1.8)	8 Pieces

Hardware List for Headboard			
3		WRENCH 1/2"*90mm	1PC
4		FULL -THREAD BOLT 5/16"*80mm	8 pieces
5		U WASHER 5/16"	8 pieces
6		NUT 5/16"	8 pieces

Hardware Bag for Footboard			
7		Wood Screw(Øx30mm)	8 pieces

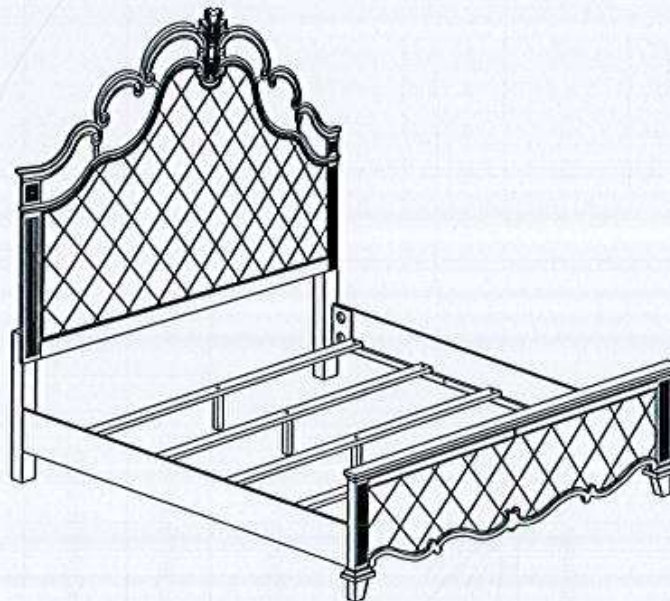

ASSEMBLY INSTRUCTIONS

QUEEN BED

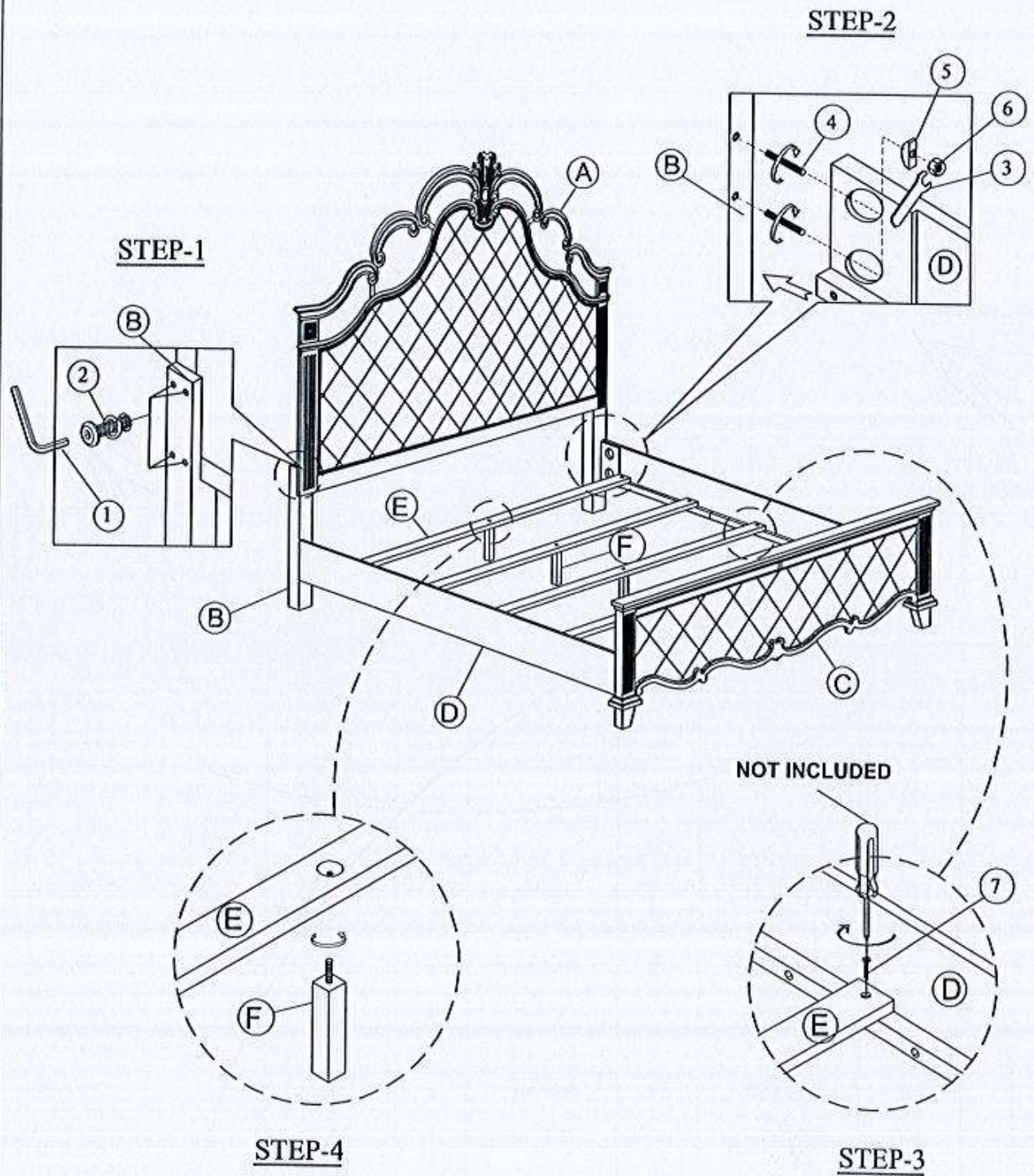







ASSEMBLY INSTRUCTIONS

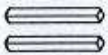



KING BED

Caution: Please read instructions thoroughly before unpacking assembly parts. Sharp, exposed staple tips can cause injury, therefore, for your protection, please remove any exposed staple used in packing.

1. We recommend that you should assemble this product with the assistance of another person; this will make assembly easier, and will help to eliminate damage to the product or injury to persons during assembly.
2. Be sure to check all packing materials carefully for small parts that may have come loose inside the carton during shipment.
3. please do not over tighten screws or bolts.
4. Please put all parts on a non-abrasive floor before assembly, and follow the assembly steps to assemble your newly purchased product correctly and efficiently.

No.	Parts List		Q'Ty
A		Headboard Panel	1PC
B		L/R Posts	2 pieces
C		Footboard	1PC
D		Side Rail	2 pieces
E		Bed Slat	4 pieces
F		Slat Support Leg	8 pieces

Hardware List for Headboard			
1		Allen Key (L57*4mm)	1PC
2		JCBC Bolt 5/16" *1.5"L	8 Pieces
		Spring Washer (Ø5/16" * 13 *1.2)	8 Pieces
		Flat Washer (Ø5/16" *19 * 1.8)	8 Pieces

Hardware List for Headboard			
3		WRENCH 1/2"*90mm	1PC
4		FULL -THREAD BOLT 5/16"*80mm	8 pieces
5		U WASHER 5/16"	8 pieces
6		NUT 5/16"	8 pieces

Hardware Bag for Footboard			
7		Wood Screw(Øx30mm)	8 pieces

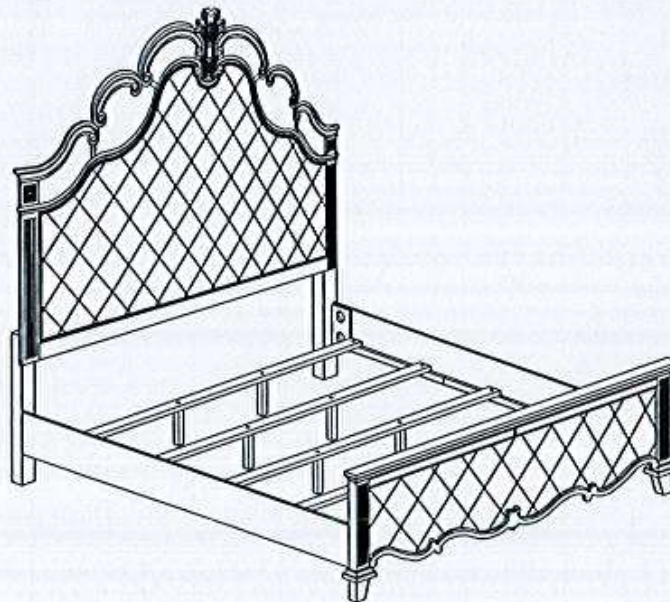

ASSEMBLY INSTRUCTIONS

KING BED

