



701 E Industrial PK Dr
Manchester NH 03109
877-364-8464
www.sunsettrading.com
- info@sunsettrading.com

**Pls Check to make sure you have all parts otherwise contact local retailer or Sunset Trading customer service at 877-364-8464"

Thank You for purchasing this Quality product. It has been engineered for easy assembly yet constructed for durability. Please take the time to read and follow the instruction while assembling.

ASSEMBLY INSTRUCTION

EAST LANE LAMP TABLE

14" x 23" x 27"H

Model : DLU-EL-1603-AG (DBVT 1608-5)

Sunset Trading[®]
a div of Sunset Furniture Intl.LLC

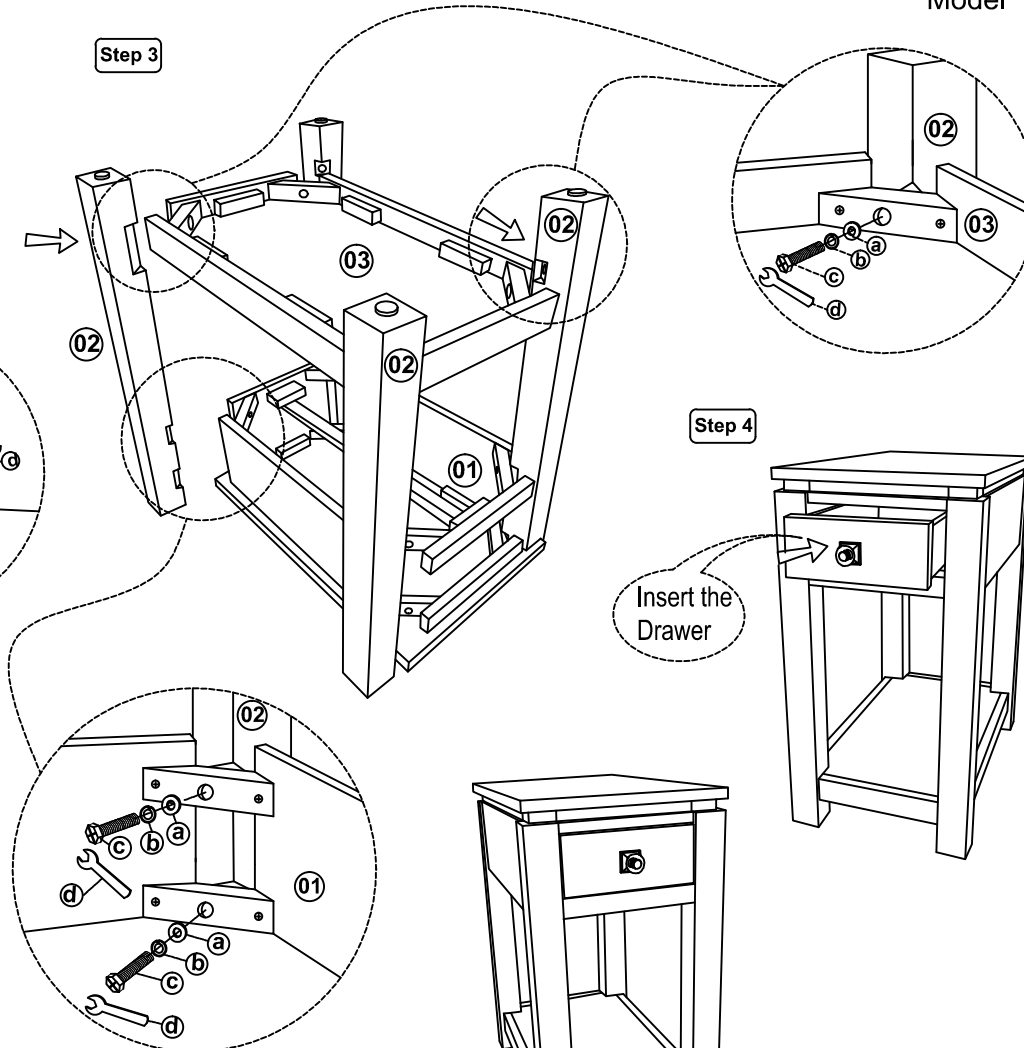
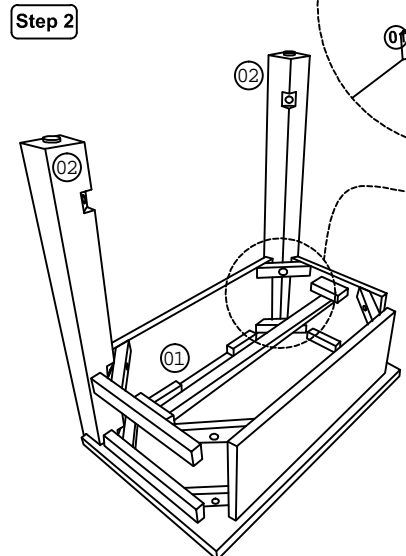
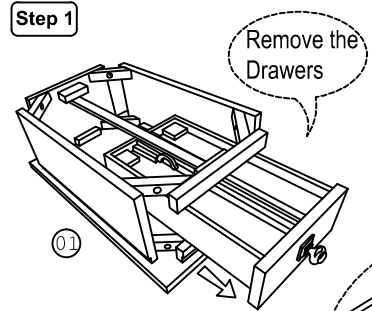

List of Part For 1 Set

Code	Figure	Part	Qty.
01		Top Assembly	1
02		Table Leg	4
03		Bottom Shelf	1

List of hardware For 1 Set

Code	Figure	Hardware	Qty.
a		Flat Washer $\frac{5}{8}$ " x 18mm	12
b		Spring Washer $\frac{5}{8}$ "	12
c		Hex.Com Bolt $\frac{5}{16}$ " x 2 $\frac{1}{2}$ "	12
d		Spannar	1

⚠ Important Notes

- * Keep all hardware parts out of reach of children.
- * Must tighten screws periodically. With use screws will become loose. Check tightness of all screws every 6-8 weeks.
- * Don't attempt to repair or modify parts that are broken or defective. Please contact the store immediately.
- * Do not tighten all screw / bolt until all completely assembled

Notes

- * Place all wooden parts on a clean and smooth surface such as a rug or carpet to avoid the parts from being scratched.
- * Check to be sure that you have all parts and hardware.
- * Remove all wrapping materials including staples & packing straps before you start to assemble.
- * Do not tighten all screws / bolts until all completely assembled.

Care And Maintenance

- * The Touch of a soft cloth is all the maintenance your wood pieces will ever need.
- * Never use harsh chemicals or abrasive cleaner as they could mark or destroy finish.

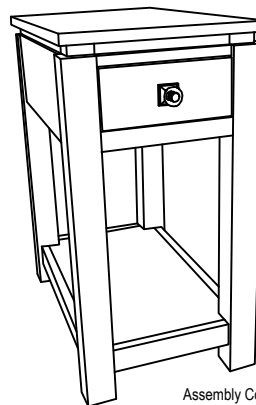

MADE IN MALAYSIA