

# ASSEMBLY INSTRUCTION







## COUNTER HEIGHT BENCH

### 30067-BENCH

Caution: Please read instructions thoroughly before unpacking assembly parts. Sharp, exposed staple tips can cause injury, therefore, for your protection, please remove any exposed staples used in packing.





1. We recommend that you should assemble this product with the assistance of another person, this will make assembly easier, and will help to eliminate damage to the product or injury to persons during assembly.
2. Be sure to check all packing materials carefully for small parts that may have come loose inside the carton during shipment.
3. Please put all parts on a non-abrasive floor before assembly, and follow the assembly steps to assemble your newly purchased product correctly and efficiently.
4. Please do not fully tighten any screws or bolts until last step.
5. Periodically check to ensure that all connectors (bolts,screw,etc) are tight.

#### PART LIST

No.		PART DESC	Q'TY
A		SEAT CUSHION	1
B		RIGHT BENCH LEG	2
C		LEFT BENCH LEG	2
D		LONG TRETCHER	2
E		SHORT STRETCHER	2
F		MIDDLE STRETCHER	1

 Only tighten all bolts when all bolts aligned with bolt inserts .

#### HARDWARE LIST

No.		HARDWARE DESC	Q'TY
1		ALLEN BOLT (5/16"x2-1/4")	8
2		SPRING WASHER (5/16)	8
3		FLAT WASHER (5/16"x19*1.5mm)	8
4		SCREW #M4x38mm	10
5		ALLEN KEY (M5x68mm)	1

Notice:Please don't over tighten all screws until last step.

Notice:Estimated assembly time:10-15 min

#### STEP 1

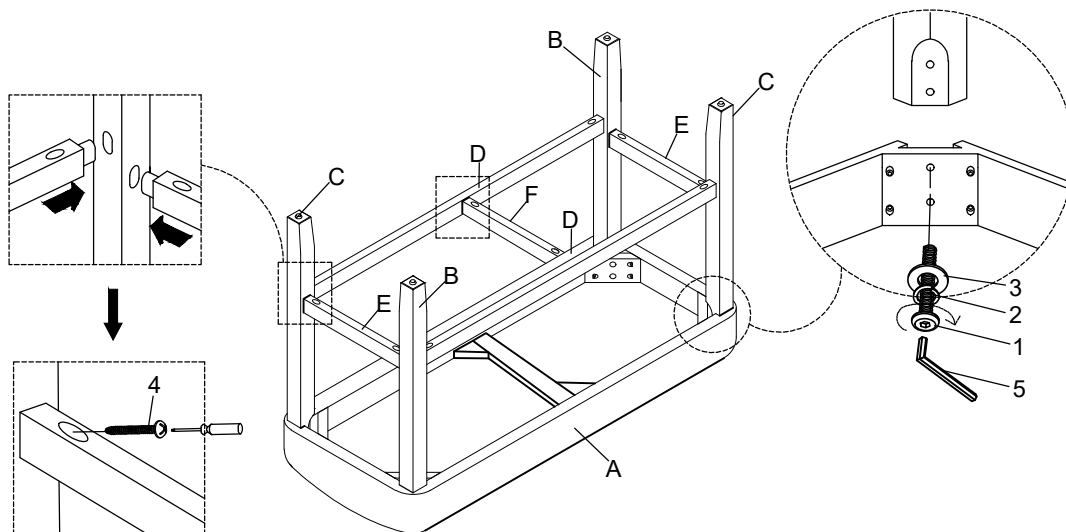

#### STEP 2: Completed

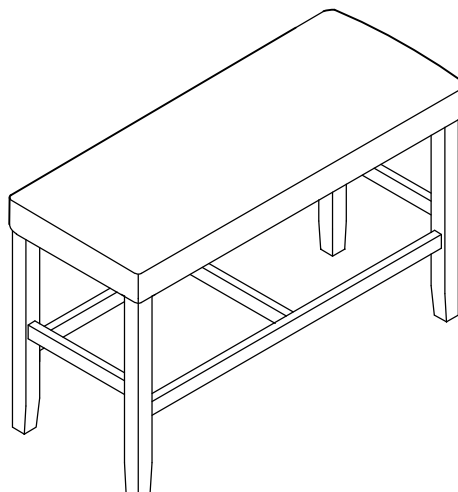

NOTE : Periodically check to ensure that all connectors (bolt, screws, etc.) are tight.