

ASSEMBLY INSTRUCTIONS

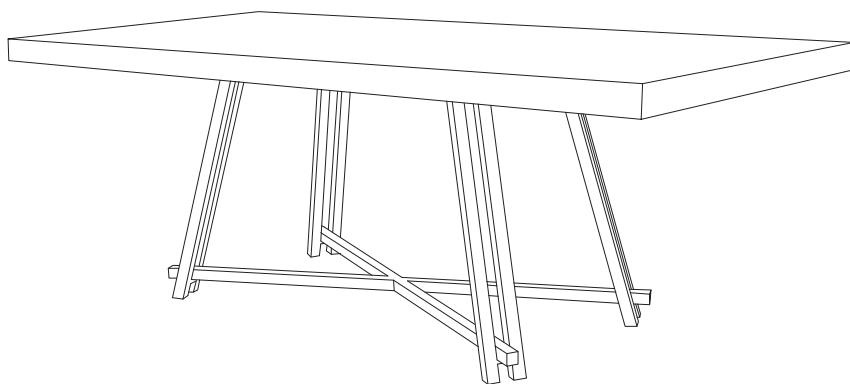

TOOLS REQUIRED



Screwdriver
(Not included)



(Included)
Allen Wrench



2 - People

ASSEMBLY RATING



EASY —————> DIFFICULT

The Assembly Rating is a 5-point system showing the level of effort needed to assemble a specific product.

VERSION # 24-05-20



CHECK BEFORE STARTING

Are you missing anything?
Double-check all parts, hardware and accessories listed are all accounted for.

Should we send any replacements?
Are there any irregularities or flaws in the parts? We can send replacements!

Check out our Quick Tips!
We recommend reviewing the pre-assembly handouts. Even experts need a refresher now and then!

Prep Time!
Please review the assembly instructions and all diagrams prior to assembling.

PRE ASSEMBLY INTRODUCTION

We understand building ready-to-assemble furniture can be a challenging experience for some. To help avoid confusion, we have provided some helpful tips that may speed up the process.



Teamwork

ALWAYS have at least two people to help with transporting and assembling the product to avoid potential injury and/or damage.



Suitable Location

Assembling near the area of the intended location is highly recommended.



Sufficient Space

Make sure you have enough space to move around during the assembly.



Avoid Scratches

Use cardboard, blankets or a carpeted area while assembling furniture to prevent to prevent scratches and damages.

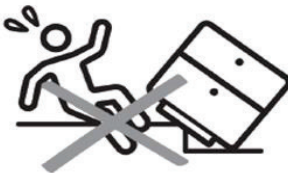

Flat Surface

Make sure the furniture rests on a flat and level surface with each leg evenly touching the floor.

ASSEMBLY AND CARE ADVICE



FAILURE TO FOLLOW THE GUIDELINES BELOW MAY RESULT IN INJURY AND/OR PROPERTY DAMAGE.



Position each part correctly and insert screws or bolts into their respective holes.

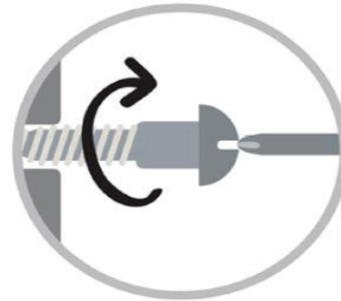

Turn clockwise to tighten and only tighten when step is completed or when instructed to do so.



Use the appropriate hand tools or power tools for assembly. Select steps, such as tightening screws and/or bolts, may require hand tools to avoid causing damage during assembly.



Save the instructions and store any supplied tools for later maintenance.



After two weeks, check and tighten any loose hardware and repeat again every six months thereafter.

IT IS THE USER'S RESPONSIBILITY TO MAINTAIN THE FURNITURE. THE HARDWARE MAY LOOSEN OVER TIME AND MAY CAUSE THE FURNITURE TO BE WOBBLY AND UNABLE TO SUPPORT ITS INTENDED WEIGHT CAPACITY. THIS MAY LEAD TO COLLAPSE AND MAY CAUSE SERIOUS INJURY.

TABLE



- Please keep instructions for future reference.
- Check the quantity and irregularity of parts and hardware before you start.

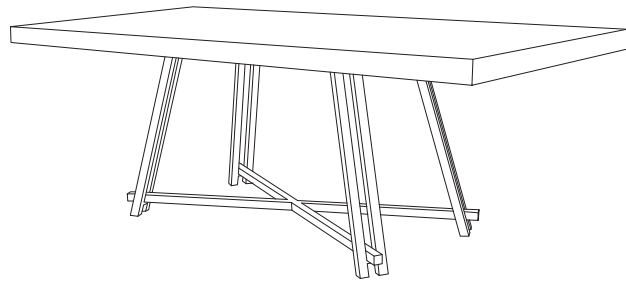

PARTS

(P1) - 1 PC



TABLE TOP

(P2) - 4 PCS



METAL LEG FRAME

(P3) - 1 PC

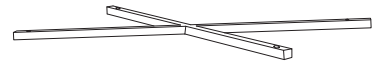

" X " METAL STRETCHER

HARDWARE

(H1) - 20 PCS



M6 x 20 mm JCBC SCREW

(H2) - 20 PCS



SPRING WASHER

(H3) - 20 PCS



FLAT WASHER

(H4) - 1 PC



ALLEN KEY

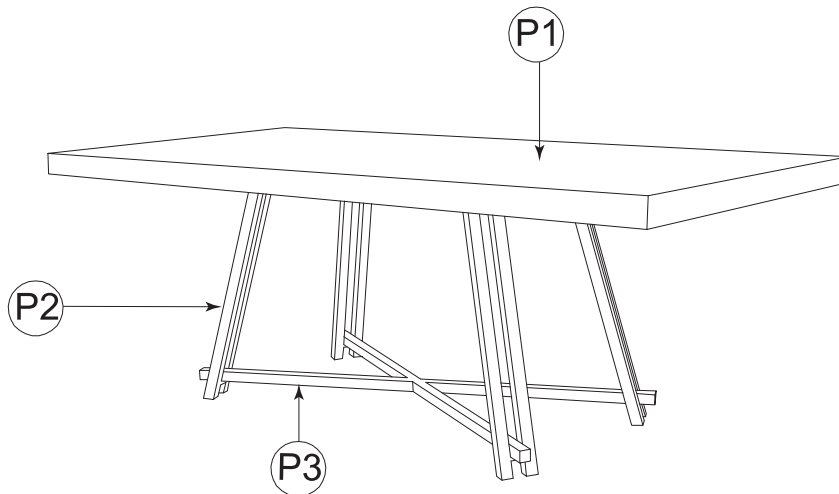

packed in 1 carton







Please read instructions carefully

Remove all wrapping materials, staples and packing straps from the carton. Refer to Parts List and Hardware List and ensure they are complete before you start assembling. Place all wooden parts on a clean, flat and soft surface (e.g carpet or rug) to prevent parts from being scratched.

CAUTIONS: 1) DO NOT FULLY TIGHTEN BOLTS AND NUTS UNTIL ALL PARTS HAVE BEEN ASSEMBLED.

2) DO NOT OVER-TIGHTEN BOLTS AND NUTS .

3) KEEP ALL HARDWARE PARTS OUT OF REACH OF CHILDREN.

| Carton | Designation | Part List | Hardware List |
|--------|---------------------|--|--|
| | TABLE TOP |  P1 x 1pc |  H1 x 20pc |
| | METAL LEG FRAME |  P2 x 4pc | M6x20mm JCBC SCREW |
| | "X" METAL STRETCHER |  P3 x 1pc |  H2 x 20pc |
| | | | Spring Washer |
| | | |  H3 x 20pc |
| | | | Flat Washer |
| | | |  H4 x 1pc |
| | | | Allen Key |

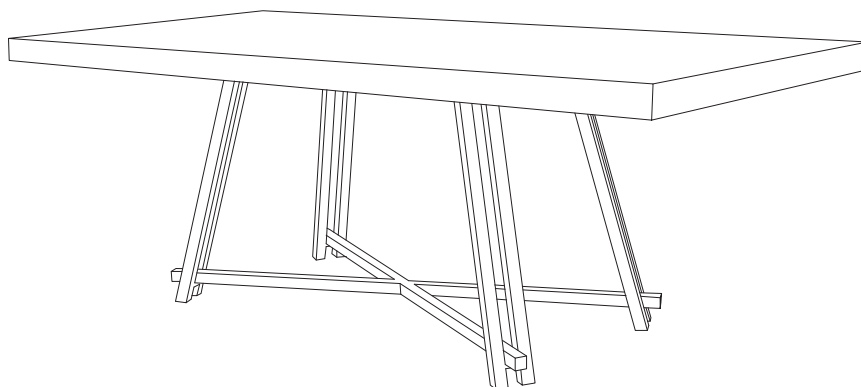





COMPLETE ASSEMBLY

ASSEMBLY INSTRUCTIONS TABLE

PARTS LIST

| NO. | COMPONENT | QTY. |
|-----|---------------------|------|
| P1 | TABLE TOP | 1 |
| P2 | METAL LEG FRAME | 4 |
| P3 | "X" METAL STRETCHER | 1 |

HARDWARE LIST

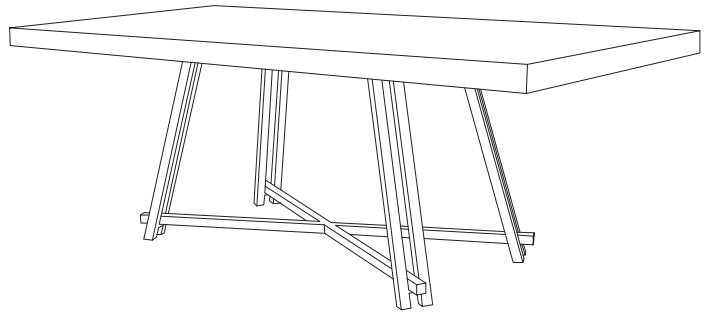

| NO. | DESCRIPTION | QTY. |
|-----|--|------|
| H1 | JCBC SCREW M6 x 20MM  | 20 |
| H2 | SPRING WASHER  | 20 |
| H3 | FLAT WASHER  | 20 |
| H4 | ALLEN KEY  | 1 |



COMPLETE ASSEMBLY

STEP 1

Assemble two of the Legs (P2) to the 'X' Metal leg (P3) by aligning the Bolts (H1) that fit with the Spring Washer (H2) and the Flat Washer (H3). Tighten all the bolts using Allen key (H4), but not fully tighten yet.

| | |
|--------|---|
| H1 x 2 |  M6 x 20mm |
| H2 x 2 |  |
| H3 x 2 |  |

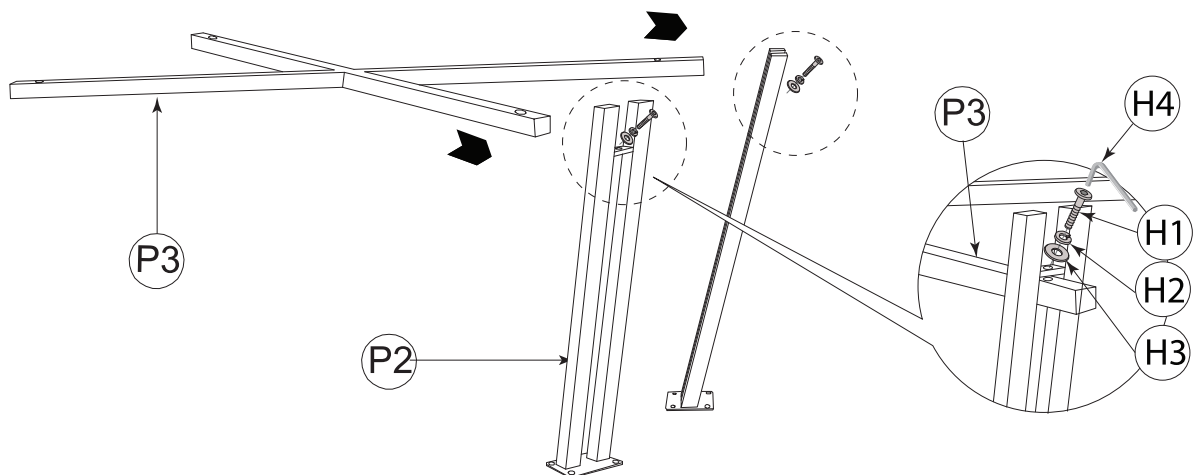

STEP 2

Assemble the two other Legs (P2) into the 'X' Metal leg (P3) by aligning the Bolts (H1) that fit with the Spring Washer (H2) & the Flat Washer (H3). Tighten all the bolts using Allen key (H4), but not fully tighten yet.

H1 x 2 
M6 x 20mm

H2 x 2 

H3 x 2 

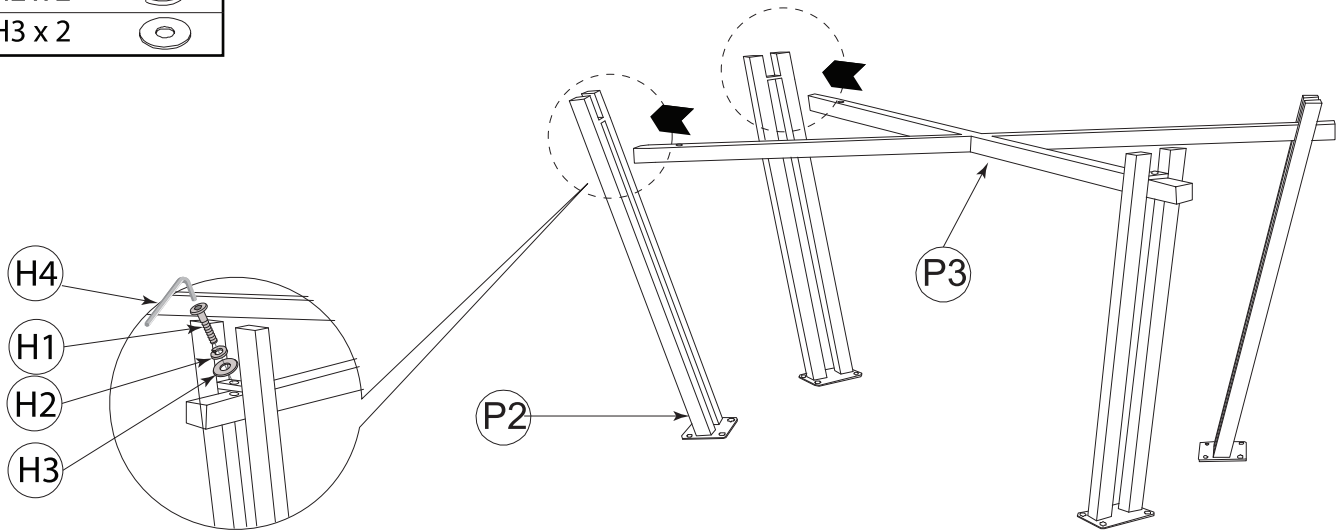

STEP 3

Attach the assembled leg frames to the underside of the Table Top (P1), align the Bolts (H1) that fit with the Spring washer (H2) & Flat washer (H3). Tighten all the bolts using Allen key (H4), and fully tighten all the bolts.

H1 x 16 
M6 x 20mm

H2 x 16 

H3 x 16 

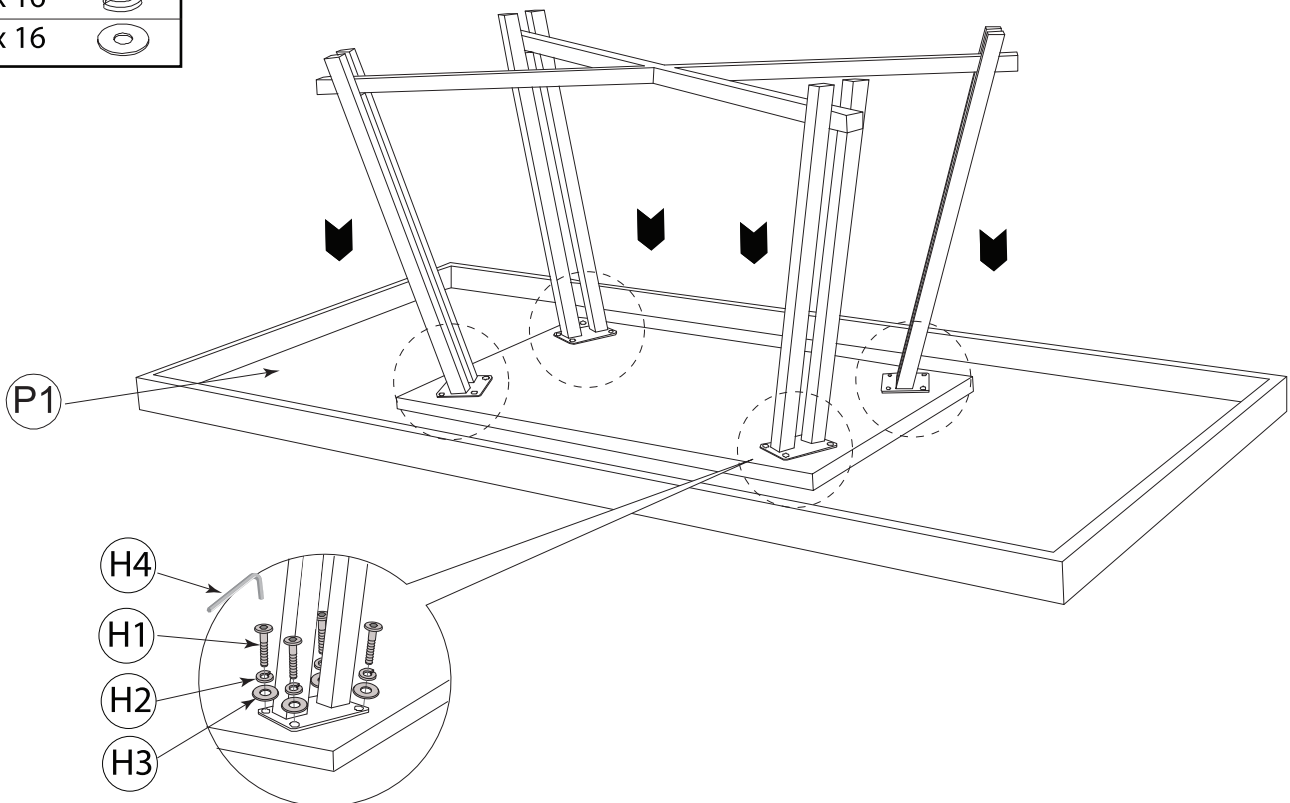

GET THE HELP OF TWO OR MORE ADULT PEOPLE TO PUT THE TABLE UPRIGHT CAREFULLY.
Please make sure the Table stands level on a hard, flat surface. Use the Allen key (H4) to tighten all the Bolts fully and ensure the Table does not wobble.

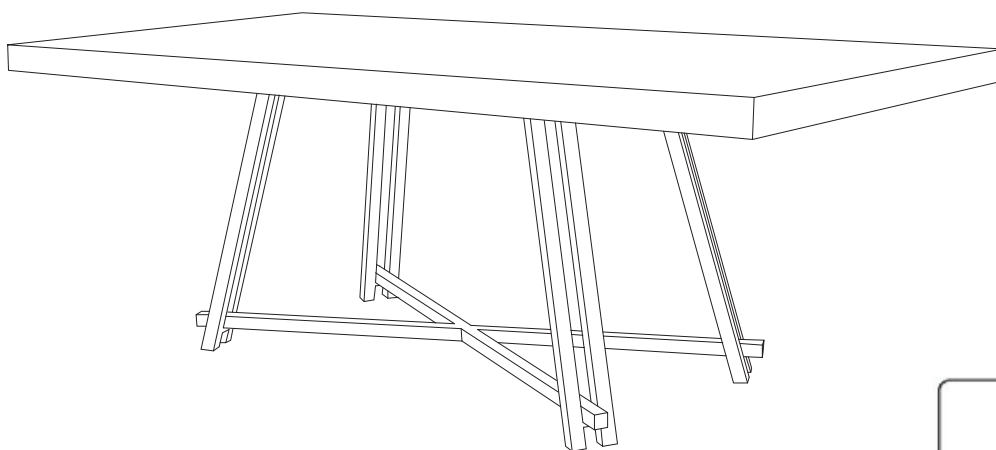

ASSEMBLY COMPLETED



Please ensure the furniture rests on an even and flat surface. If the product wobbles or feels loose, double-check all bolts and/or screws are properly tightened and secured.

✓ **Keep this handy!**

Please retain this instruction manual and any order-related information for future reference.

✓ **Lift, don't drag!**

To avoid damage to product please always LIFT the product when transporting or adjusting the placement.

This product is intended for RESIDENTIAL USE ONLY and not for commercial use .

CARE AND MAINTENANCE

SAFETY - To avoid any risk of suffocation to children or animals, dispose off the plastic bags immediately.

CLEANING - Clean with damp cloth and mild detergent. Do not use bleach or abrasive products.

FITTINGS - Tighten bolts and nuts from time to time to ensure all parts of product are securely fitted.