

ASSEMBLY INSTRUCTIONS

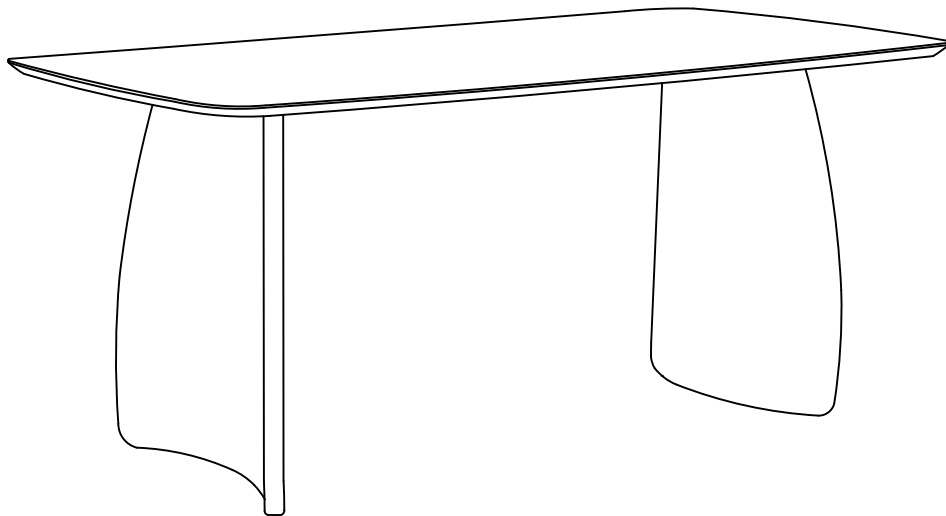

TOOLS REQUIRED



Allen Wrench
(Included)



2 - People

ASSEMBLY RATING



EASY → DIFFICULT

The Assembly Rating is a 5-point system showing the level of the effort needed to assemble a specific product.



CHECK BEFORE STARTING

Are you missing anything?

Double-check all parts, hardware and accessories listed are all accounted for.

Should we send any replacements?

Are there any irregularities or flaws in the parts? We can send replacements!

Check out our Quick Tips!

We recommend reviewing the pre-assembly handouts. Even experts need a refresher now and then!

Prep Time!

Please review the assembly instructions and all diagrams prior to assembling.

PRE ASSEMBLY INSTRUCTION

We understand building ready-to-assemble furniture can be a challenging experience for some. To help avoid confusion, we have provided some helpful tips that may speed up the process.



Teamwork

ALWAYS have at least two people to help with transporting and assembling the product to avoid potential injury and/or damage.



Suitable Location

Assembling near the area of the intended location is highly recommended.



Sufficient Space

Make sure you have enough space to move around during the assembly.



Avoid Scratches

Use cardboard, blankets or a carpeted area while assembling furniture to prevent scratches and damages.

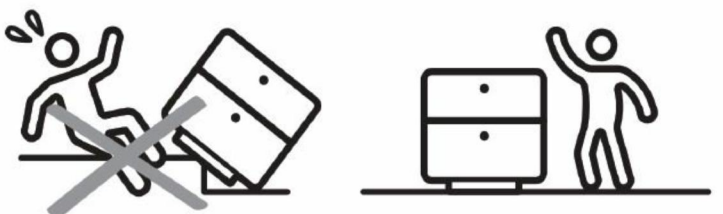

Flat Surface

Make sure the furniture rests on a flat and level surface with each leg evenly touching the floor.

ASSEMBLY AND CARE ADVICE



FAILURE TO FOLLOW THE GUIDELINES BELOW MAY RESULT IN INJURY AND/OR PROPERTY DAMAGE.



Position each part correctly, and insert screws or bolts into their respective holes.



Turn clockwise to tighten and only tighten when step is completed or when instructed to do so.



Use the appropriate handtools or power tools for assembly. Select steps, such as tightening screws and/or bolts, may require handtools to avoid causing damage during assembly.



Save the instruction and store any supplied tools for later maintenance.



After two weeks, check and tighten any loose hardware and repeat again every six months thereafter.

IT IS THE USER'S RESPONSIBILITY MAINTAIN THE FURNITURE. THE HARDWARE MAY LOOSEN OVER TIME AND MAY CAUSE THE FURNITURE TO WOBBLY AND UNABLE TO SUPPORT ITS INTENDED WEIGHT CAPACITY. THIS MAY LEAD TO COLLAPSE AND MAY USE SERIOUS INJURY.

DINING TABLE



- Please keep instructions for future reference.
- Check the quantity and irregularity of parts and hardware before you start.

PARTS

① 1 pc



TABLE TOP

② 2 pcs



TABLE LEG

③ 1 pc

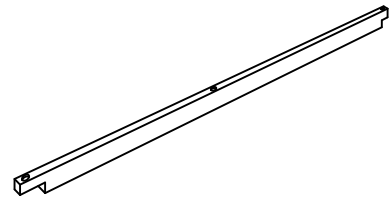

TOP STRETCHER

HARDWARE

Ⓐ 10 pcs

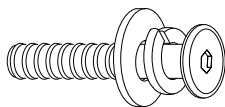

JCBC M6 x 40mm + S/W M6
+ F/W M6 x 19mm

Ⓑ 3 pcs

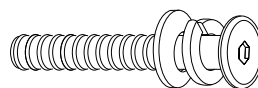





JCBC M6 x 60mm + S/W M6
+ F/W M6 x 13mm

Ⓒ 1 pc

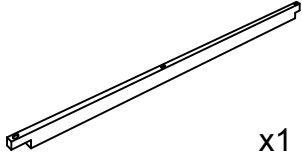

ALLEN KEY M4
(BALL SHAPE)

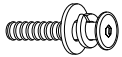
packed in 2 cartons

Carton	Designation	Parts	Hardware
	Table Top	#1  x1	
	Top Stretcher	#3  x1	
	Table Leg	#2  x2	 #A x10pcs  #B x3pcs  #C x1pc

ASSEMBLY INSTRUCTIONS

OPTION 1

1

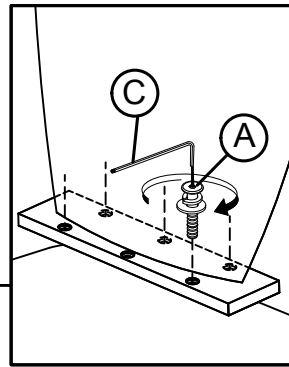
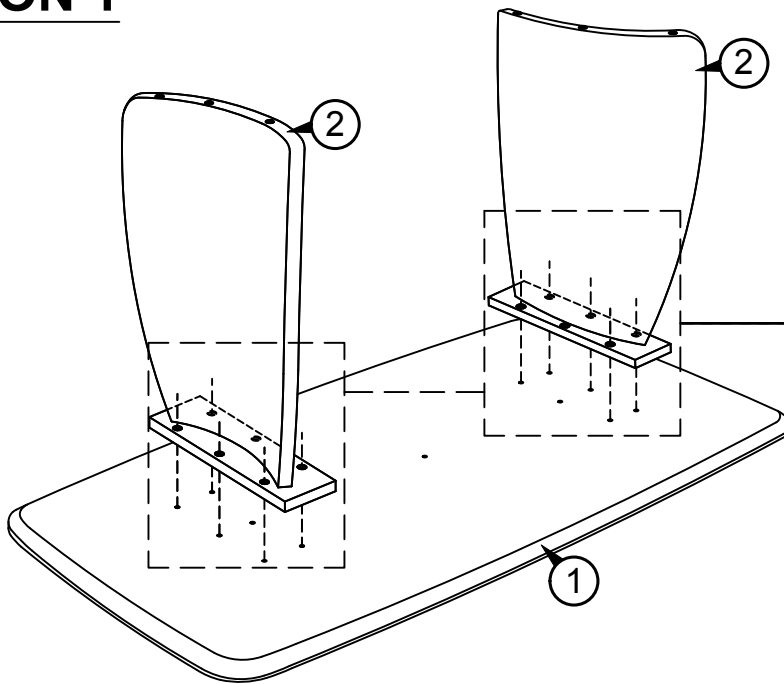

**ATTENTION:
DO NOT FULLY
TIGHTEN THE BOLTS**

2

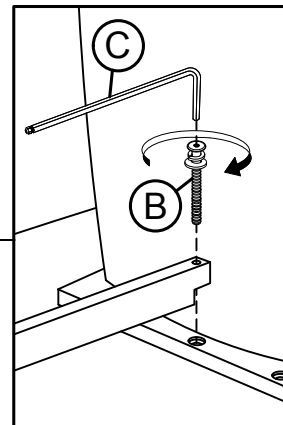
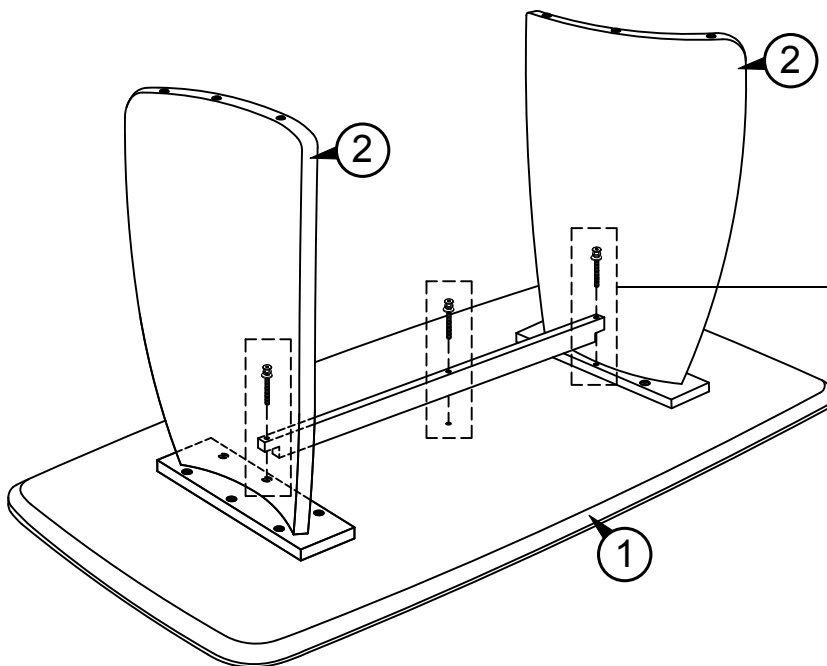

**FULLY TIGHTEN ALL
BOLTS BUT DO NOT
OVER-TIGHTEN**

3

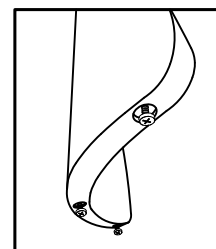
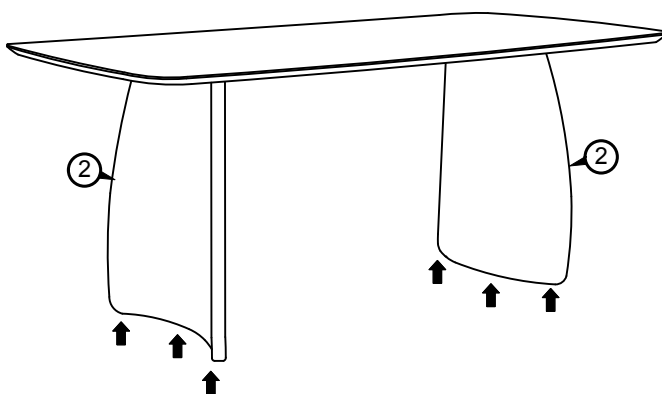

Turn clockwise or anti-clockwise
to adjust leg leveler.

ASSEMBLY INSTRUCTIONS

OPTION 2

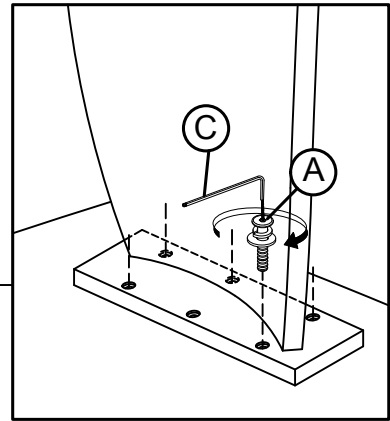
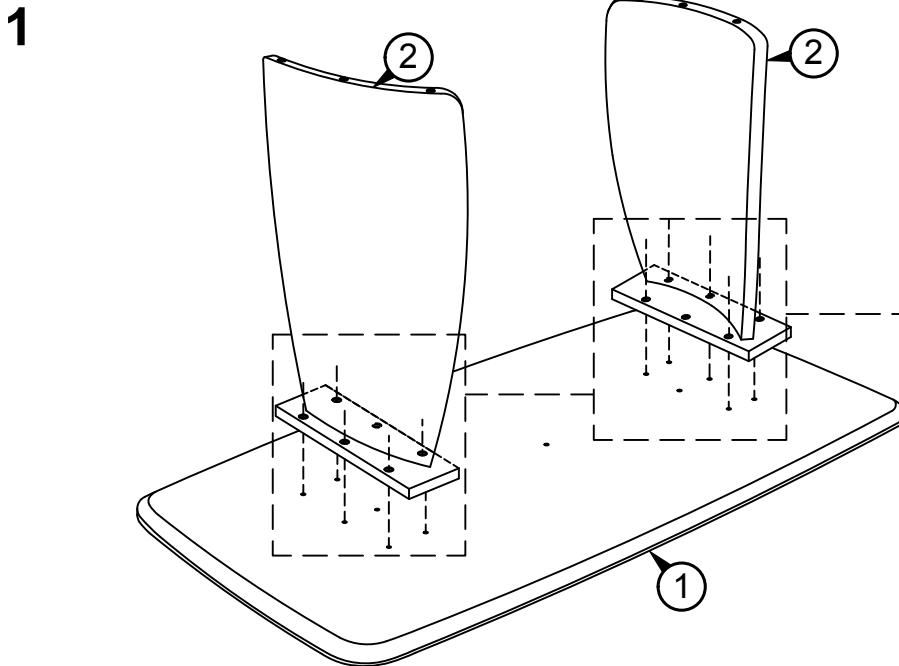

**ATTENTION:
DO NOT FULLY
TIGHTEN THE BOLTS**

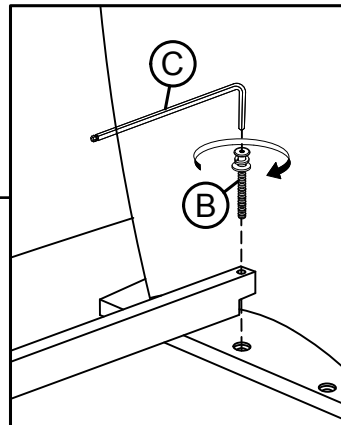
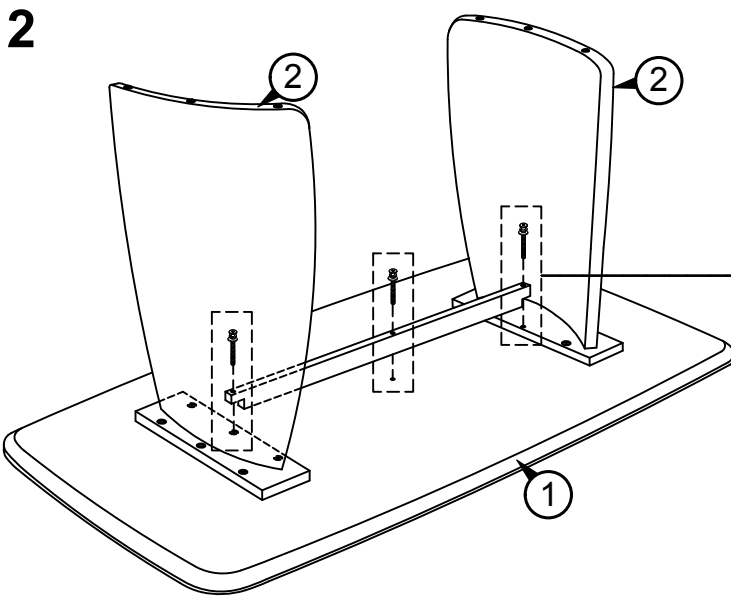

**FULLY TIGHTEN
ALL BOLTS BUT
DO NOT
OVER-TIGHTEN**

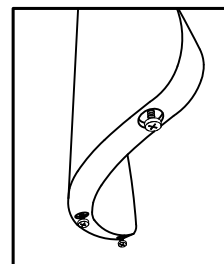
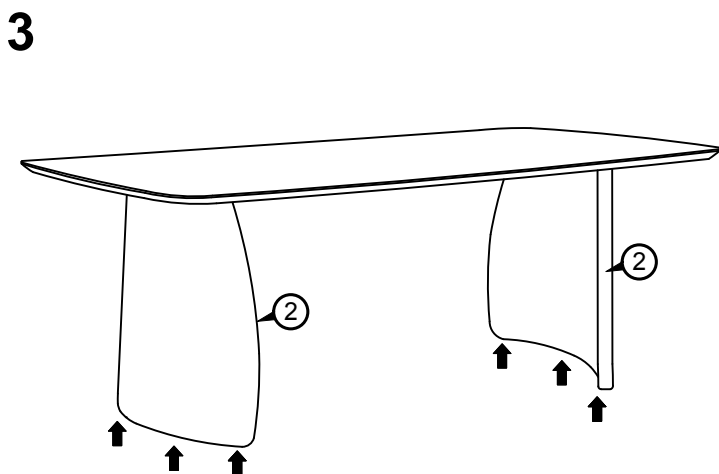

Turn clockwise or anti-clockwise
to adjust leg leveller.

ASSEMBLY COMPLETED

Please ensure the furniture rests on an even and flat surface. If the product wobbles or feels loose, double-check all bolts and/or screws are properly tightened and secured.



Keep this handy!

Please retain this instruction manual and any order-related information for future reference.

Lift, don't drag!

To avoid damage to product please always LIFT the product when transporting or adjusting the placement.

This product is intended for RESIDENTIAL USE ONLY and not for commercial use.

ASSEMBLY INSTRUCTIONS

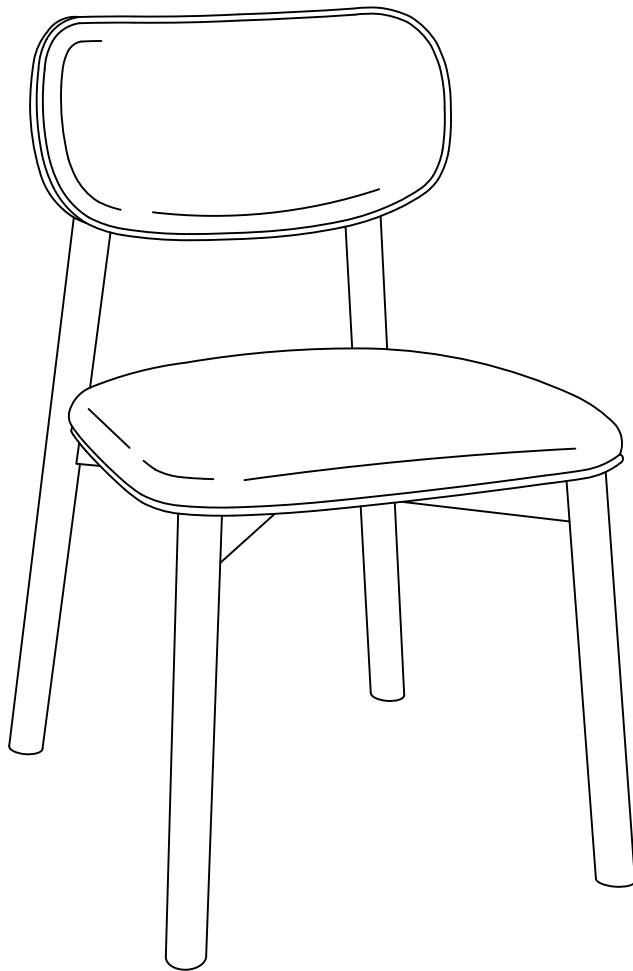

TOOLS REQUIRED



Screwdriver
(Not included)



Allen Wrench
(Included)



2 - People

ASSEMBLY RATING



EASY → DIFFICULT

The Assembly Rating is a 5-point system showing the level of the effort needed to assemble a specific product.



CHECK BEFORE STARTING

Are you missing anything?

Double-check all parts, hardware and accessories listed are all accounted for.

Should we send any replacements?

Are there any irregularities or flaws in the parts? We can send replacements!

Check out our Quick Tips!

We recommend reviewing the pre-assembly handouts. Even experts need a refresher now and then!

Prep Time!

Please review the assembly instructions and all diagrams prior to assembling.

PRE ASSEMBLY INSTRUCTION

We understand building ready-to-assemble furniture can be a challenging experience for some. To help avoid confusion, we have provided some helpful tips that may speed up the process.



Teamwork

ALWAYS have at least two people to help with transporting and assembling the product to avoid potential injury and/or damage.

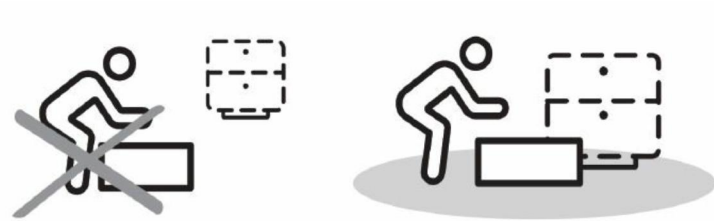

Suitable Location

Assembling near the area of the intended location is highly recommended.



Sufficient Space

Make sure you have enough space to move around during the assembly.

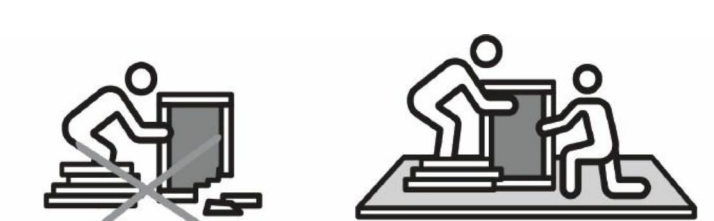

Avoid Scratches

Use cardboard, blankets or a carpeted area while assembling furniture to prevent scratches and damages.

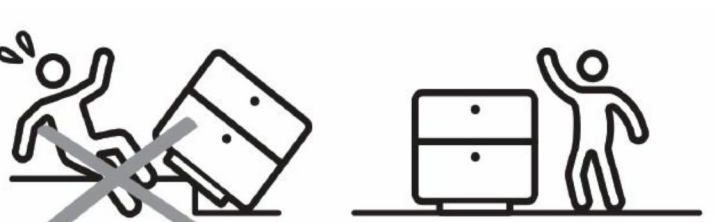

Flat Surface

Make sure the furniture rests on a flat and level surface with each leg evenly touching the floor.

ASSEMBLY AND CARE ADVICE



FAILURE TO FOLLOW THE GUIDELINES BELOW MAY RESULT IN INJURY AND/OR PROPERTY DAMAGE.



Position each part correctly, and insert screws or bolts into their respective holes.

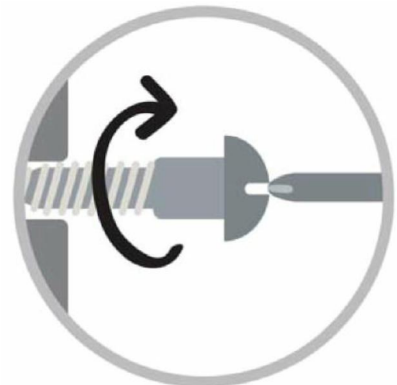

Turn clockwise to tighten and only tighten when step is completed or when instructed to do so.



Use the appropriate handtools or power tools for assembly. Select steps, such as tightening screws and/or bolts, may require handtools to avoid causing damage during assembly.



Save the instruction and store any supplied tools for later maintenance.



After two weeks, check and tighten any loose hardware and repeat again every six months thereafter.

IT IS THE USER'S RESPONSIBILITY MAINTAIN THE FURNITURE. THE HARDWARE MAY LOOSEN OVER TIME AND MAY CAUSE THE FURNITURE TO WOBBLY AND UNABLE TO SUPPORT ITS INTENDED WEIGHT CAPACITY. THIS MAY LEAD TO COLLAPSE AND MAY USE SERIOUS INJURY.

DINING CHAIR



- Please keep instructions for future reference.
- Check the quantity and irregularity of parts and hardware before you start.

PARTS

① 1pc x 2

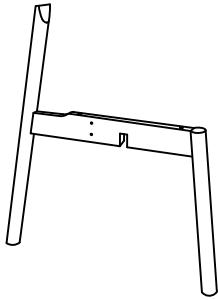

X LEG UP

② 1pc x 2

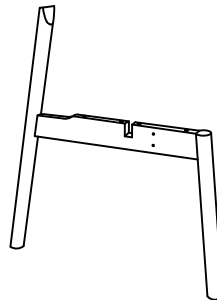

X LEG DOWN

③ 1pc x 2



TOP REST

④ 1pc x 2



CUSHION SEAT

⑤ 2pcs x 2

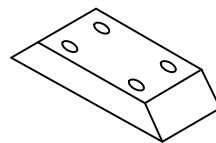

CORNER BLOCK

HARDWARE

A 4 pcs x2

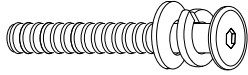

JCBC M6 x 70mm + S/W M6
+ F/W M6 x 13mm

B 1 pc x2



JCBC W M7 x 40mm

C 2 pcs x2



JCBC W M7 x 32mm

D 1 pc



ALLEN KEY M4
(BALL SHAPE)

E 8 pcs x2

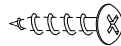

PH CB SCREW M4 x 25mm

F 2 pcs x2



WOOD BUTTON Ø14.5

ASSEMBLY INSTRUCTIONS

1

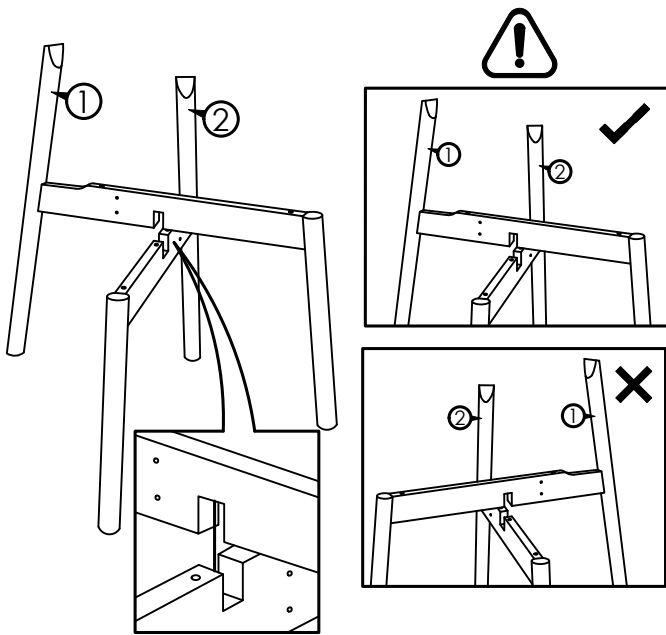

2

ATTENTION:
DO NOT FULLY TIGHTEN THE BOLTS

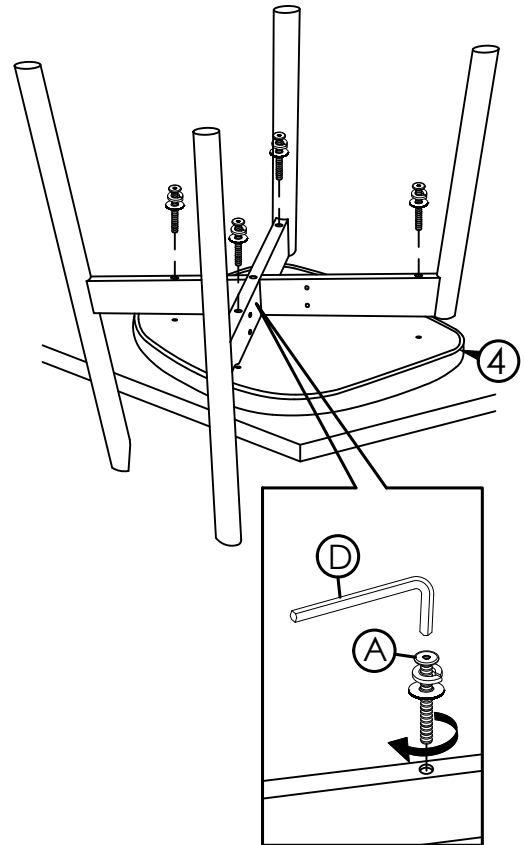

3

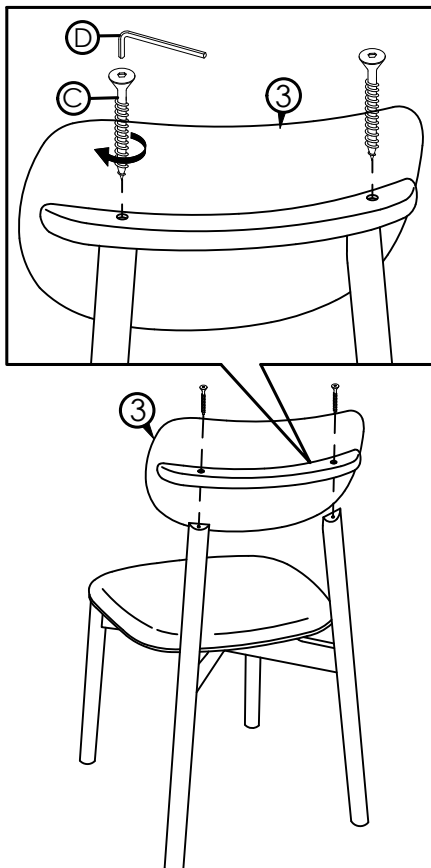

4

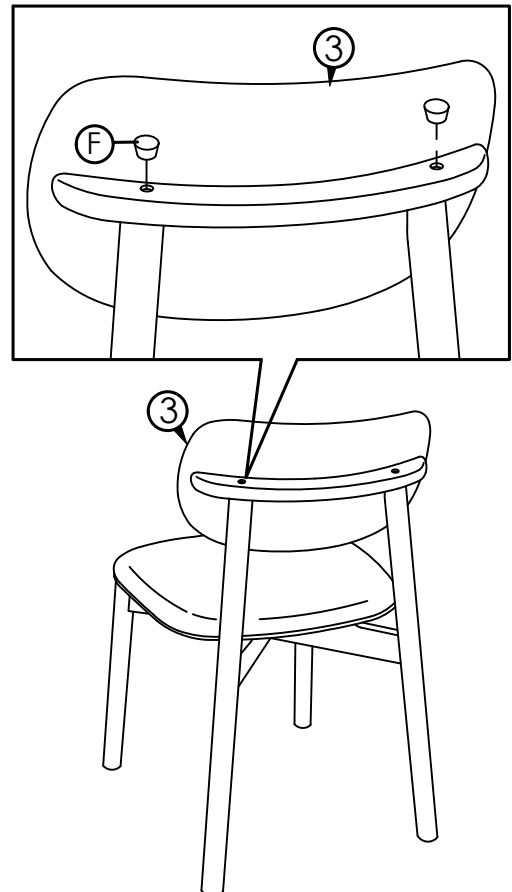

ASSEMBLY INSTRUCTIONS

5

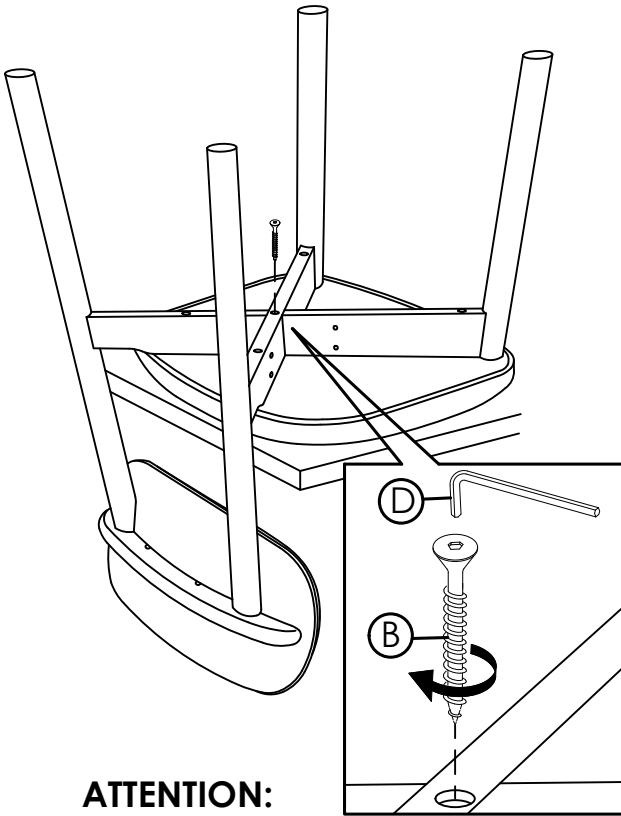

ATTENTION:
FULLY TIGHTEN ALL BOLTS BUT
DO NOT OVER-TIGHTEN

6

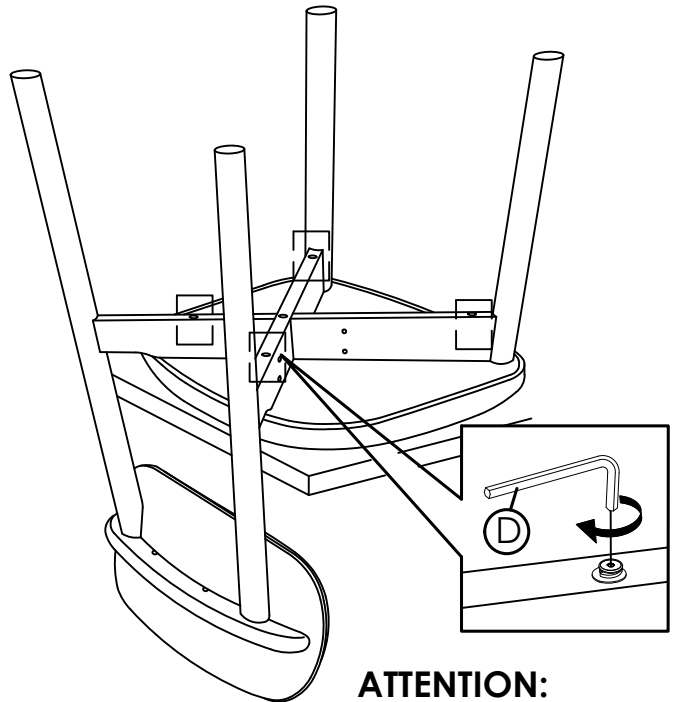

ATTENTION:
FULLY TIGHTEN
ALL BOLTS BUT DO
NOT OVER-TIGHTEN

7

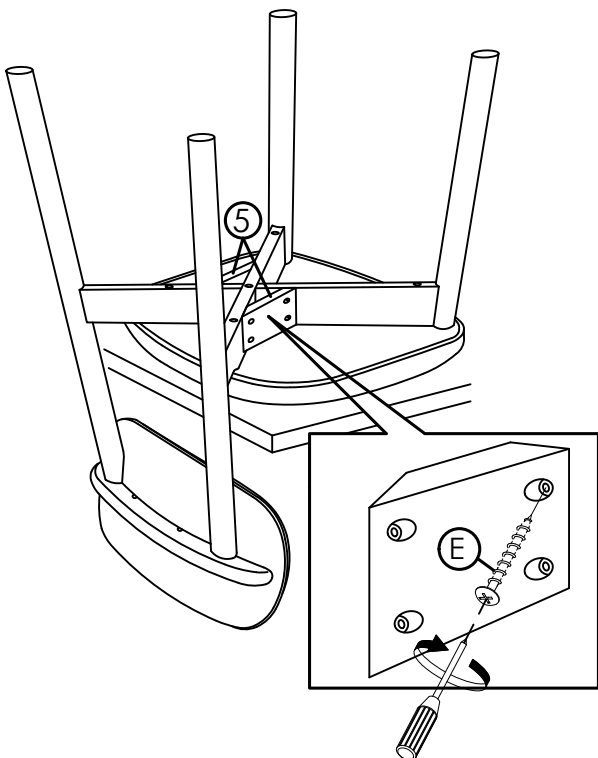

8

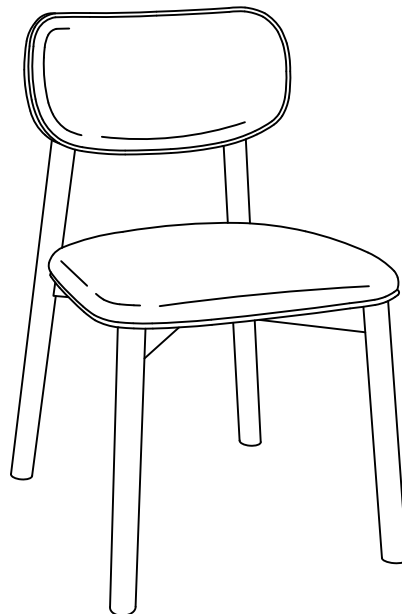

ASSEMBLY COMPLETED

Please ensure the furniture rests on an even and flat surface. If the product wobbles or feels loose, double-check all bolts and/or screws are properly tightened and secured.



✓ Keep this handy!

Please retain this instruction manual and any order-related information for future reference.



✓ Lift, don't drag!

To avoid damage to product please always LIFT the product when transporting or adjusting the placement.

This product is intended for RESIDENTIAL USE ONLY and not for commercial use.