

# ASSEMBLY INSTRUCTIONS

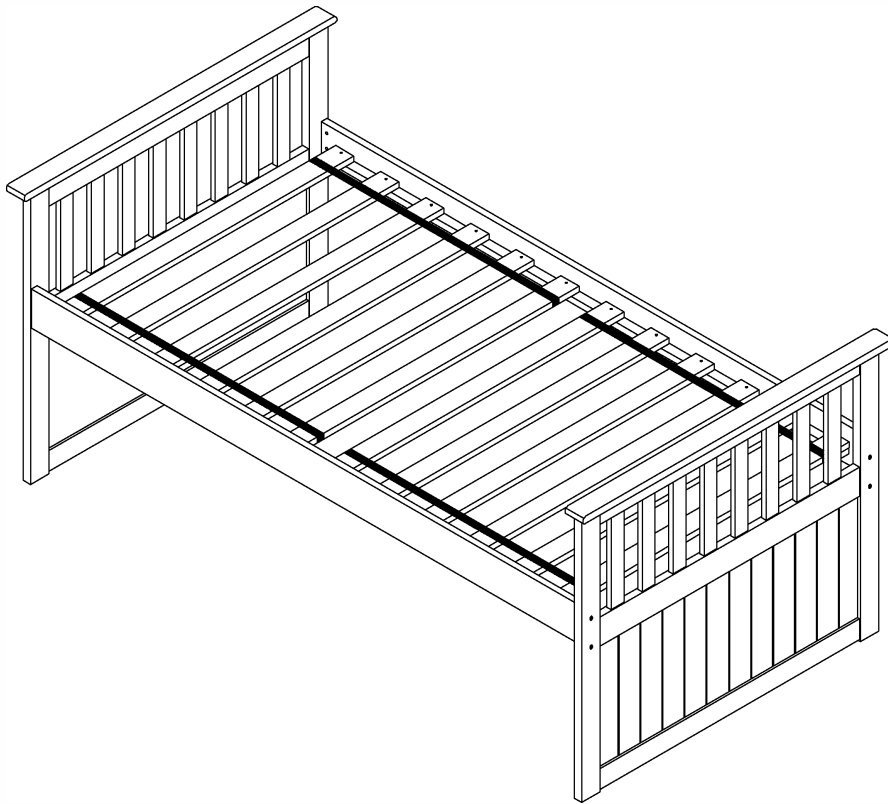

## TOOLS REQUIRED



Allen Wrench  
(Included)



Screwdriver  
(Not Included)



2 - People

## ASSEMBLY RATING



EASY —————> DIFFICULT

The Assembly Rating is a 5-point system showing the level of effort needed to assemble a specific product.



## **CHECK BEFORE STARTING**

### **Are you missing anything?**

Double-check all parts, hardware and accessories listed are all accounted for.

### **Check out our Quick Tips!**

We recommend reviewing the pre-assembly handouts. Even experts need a refresher now and then!

### **Should we send any replacements?**

Are there any irregularities or flaws in the parts? We can send replacements!

### **Prep Time!**

Please review the assembly instructions and all diagrams prior to assembling.

---

# PRE ASSEMBLY INTRODUCTION

We understand building ready-to-assemble furniture can be a challenging experience for some. To help avoid confusion, we have provided some helpful tips that may speed up the process.



## Teamwork

ALWAYS have at least two people to help with transporting and assembling the product to avoid potential injury and/or damage.



## Suitable Location

Assembling near the area of the intended location is highly recommended.



## Sufficient Space

Make sure you have enough space to move around during the assembly.



## Avoid Scratches

Use cardboard, blankets or a carpeted area while assembling furniture to prevent to prevent scratches and damages.

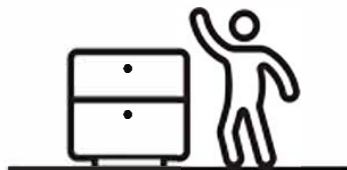

## Flat Surface

Make sure the furniture rests on a flat and level surface with each leg evenly touching the floor.

# ASSEMBLY AND CARE ADVICE



**FAILURE TO FOLLOW THE GUIDELINES BELOW MAY RESULT IN INJURY AND/OR PROPERTY DAMAGE.**



Position each part correctly and insert screws or bolts into their respective holes.

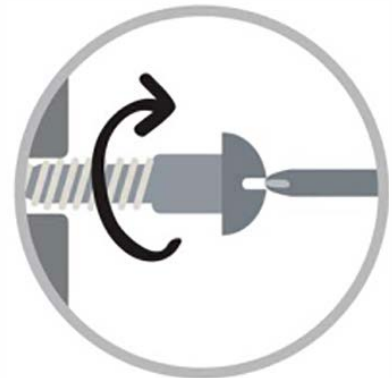

Turn clockwise to tighten and only tighten when step is completed or when instructed to do so.



Save the instructions and store any supplied tools for later maintenance.

Use the appropriate hand tools or power tools for assembly. Select steps, such as tightening screws and/or bolts, may require hand tools to avoid causing damage during assembly.



After two weeks, check and tighten any loose hardware and repeat again every six months thereafter.

**IT IS THE USER'S RESPONSIBILITY TO MAINTAIN THE FURNITURE. THE HARDWARE MAY LOOSEN OVER TIME AND MAY CAUSE THE FURNITURE TO BE WOBBLY AND UNABLE TO SUPPORT ITS INTENDED WEIGHT CAPACITY. THIS MAY LEAD TO COLLAPSE AND MAY CAUSE SERIOUS INJURY.**

# ASSEMBLY INSTRUCTIONS

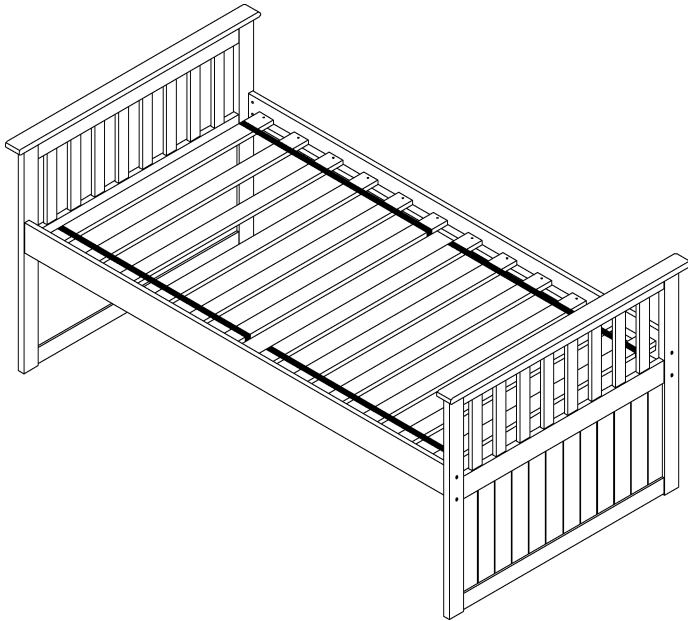







### ASSEMBLY TIPS

1. Remove hardware from box and sort by size.
2. Please check to see that all hardware and parts are present prior start of assembly.
3. Please follow attached instructions in the same sequence as numbered to assure fast and easy assembly.

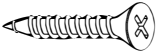

### WARNING !

1. Don't attempt to repair or modify part that are broken or defective. Please contact the store immediately.
2. This product is for home use only and not intended for commercial establishments.

HARDWARE LIST		
1		8 PCS
	JCBC M6 x 70mm	
2		8 PCS
	JCBC-W M6 x 28mm	
3		16 PCS
	WOOD SCREW 4.0 x 28mm	
4		8 PCS
	WOOD DOWEL Ø10 x 30mm	
5		8 PCS
	BARREL NUT M6 x 16mm	
6		1 PC
	ALLEN KEY M4	

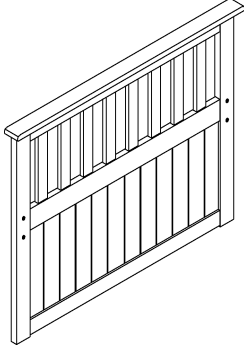
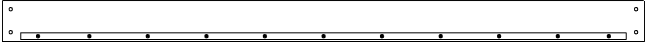
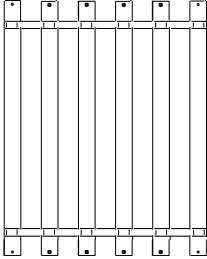
COMPONENT LIST		
A		2 SETS
	HEADBOARD / FOOTBOARD	
B		2 PCS
	SIDE RAIL	
C		2 SETS
	SLAT (PACKED IN BOX C)	

STEP 1

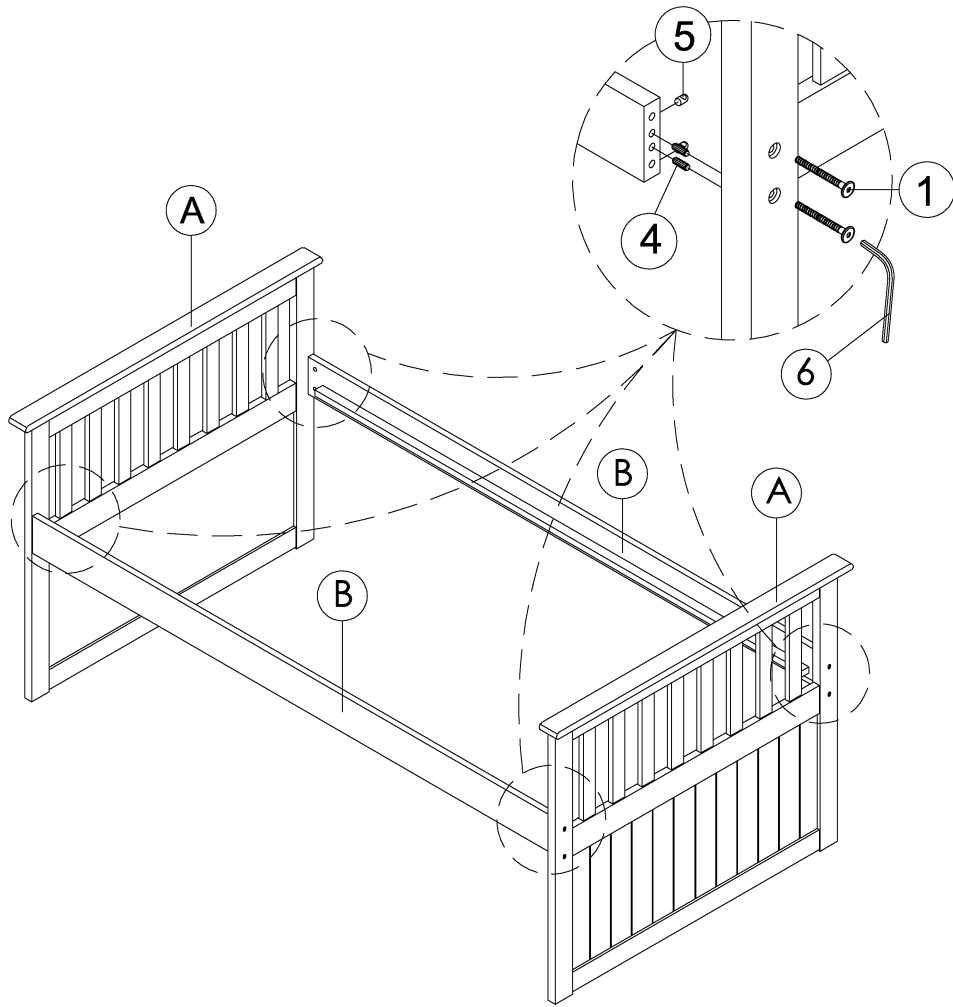

STEP 2

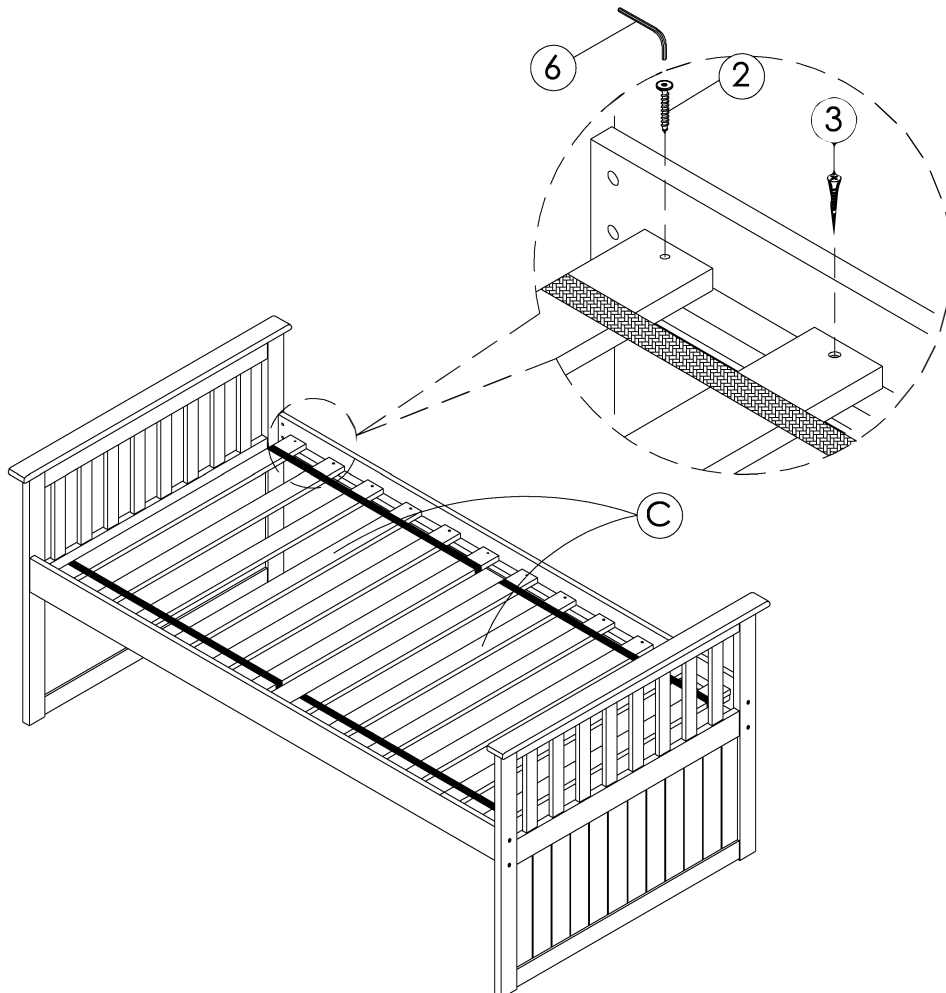

# ASSEMBLY INSTRUCTIONS

## TOOLS REQUIRED



Allen Wrench  
(Included)



Screwdriver  
(Not Included)



2 - People

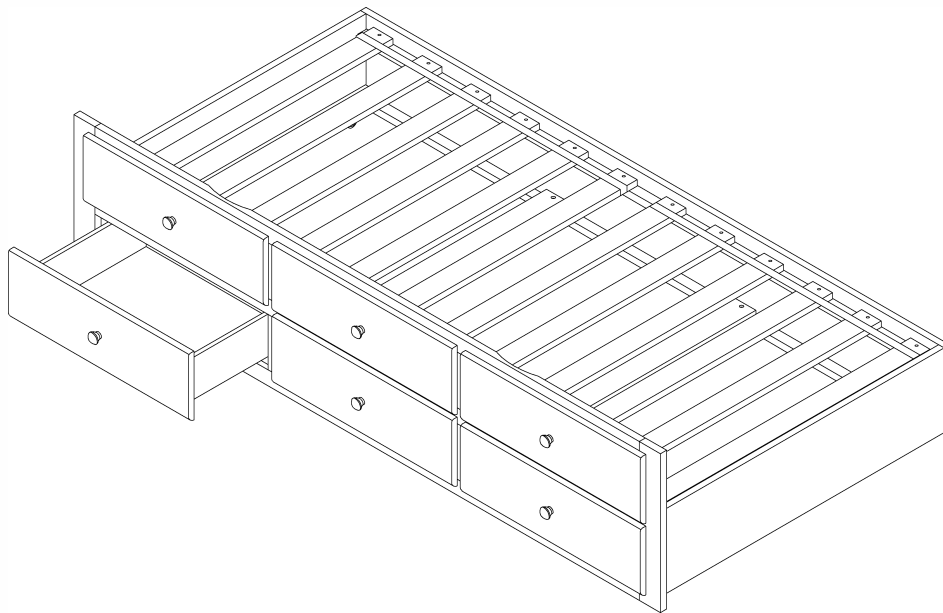

## ASSEMBLY RATING



EASY —————> DIFFICULT

The Assembly Rating is a 5-point system showing the level of effort needed to assemble a specific product.



## **CHECK BEFORE STARTING**

### **Are you missing anything?**

Double-check all parts, hardware and accessories listed are all accounted for.

### **Check out our Quick Tips!**

We recommend reviewing the pre-assembly handouts. Even experts need a refresher now and then!

### **Should we send any replacements?**

Are there any irregularities or flaws in the parts? We can send replacements!

### **Prep Time!**

Please review the assembly instructions and all diagrams prior to assembling.

---

# PRE ASSEMBLY INTRODUCTION

We understand building ready-to-assemble furniture can be a challenging experience for some. To help avoid confusion, we have provided some helpful tips that may speed up the process.



## Teamwork

ALWAYS have at least two people to help with transporting and assembling the product to avoid potential injury and/or damage.



## Suitable Location

Assembling near the area of the intended location is highly recommended.



## Sufficient Space

Make sure you have enough space to move around during the assembly.



## Avoid Scratches

Use cardboard, blankets or a carpeted area while assembling furniture to prevent to prevent scratches and damages.



## Flat Surface

Make sure the furniture rests on a flat and level surface with each leg evenly touching the floor.

# ASSEMBLY AND CARE ADVICE



**FAILURE TO FOLLOW THE GUIDELINES BELOW MAY RESULT IN INJURY AND/OR PROPERTY DAMAGE.**



Position each part correctly and insert screws or bolts into their respective holes.

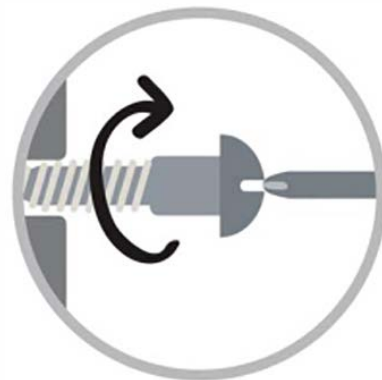

Turn clockwise to tighten and only tighten when step is completed or when instructed to do so.



Save the instructions and store any supplied tools for later maintenance.

Use the appropriate hand tools or power tools for assembly. Select steps, such as tightening screws and/or bolts, may require hand tools to avoid causing damage during assembly.



After two weeks, check and tighten any loose hardware and repeat again every six months thereafter.

**IT IS THE USER'S RESPONSIBILITY TO MAINTAIN THE FURNITURE. THE HARDWARE MAY LOOSEN OVER TIME AND MAY CAUSE THE FURNITURE TO BE WOBBLY AND UNABLE TO SUPPORT ITS INTENDED WEIGHT CAPACITY. THIS MAY LEAD TO COLLAPSE AND MAY CAUSE SERIOUS INJURY.**

# ASSEMBLY INSTRUCTIONS

## ASSEMBLY TIPS

1. Remove hardware from box and sort by size.
2. Please check to see that all hardware and parts are present prior start of assembly.
3. Please follow attached instructions in the same sequence as numbered to assure fast and easy assembly.







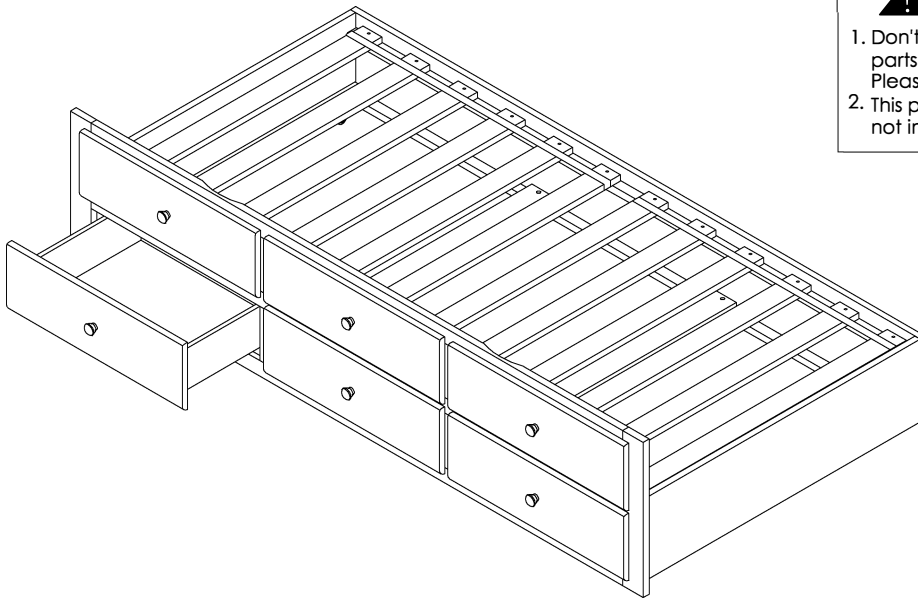





## Warning !

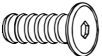



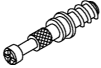
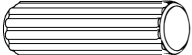

1. Don't attempt to repair or modify parts that are broken or defective. Please contact the store immediately.
2. This product is for home use only and not intended for commercial establishments.

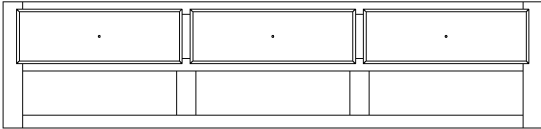

## HARDWARE LIST

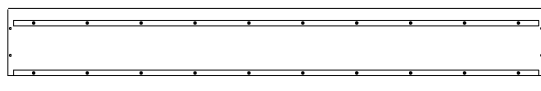
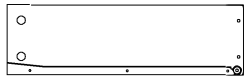
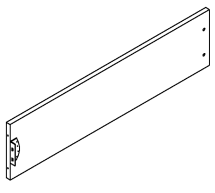
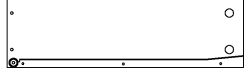
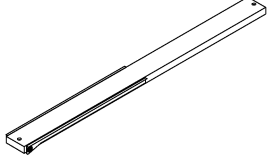
1	 JCBC M6 x 60mm	4 PCS	8	 M4 ALLEN KEY	1 PC
2	 JCBC M6 x 35mm	8 PCS	9	 T/H MACHINE SCREW 4.0 x 30mm	6 PCS
3	 JCBC M6 x 16mm	4 PCS	10	 WOODEN HANDLE	6 PCS
4	 JCBC - W M6 x 28mm	8 PCS	11	 WOOD DOWEL Ø6 x 30mm	12 PCS
5	 WOOD SCREW 4.0 x 28mm	32 PCS	12	 MINIFIX CAM	18 PCS
6	 BARREL NUT M6 x 13mm	4 PCS	13	 MINIFIX BOLT	18 PCS
7	 WOOD DOWEL Ø8 x 30mm	4 PCS			

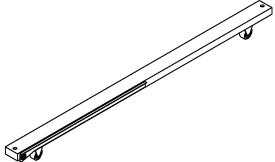
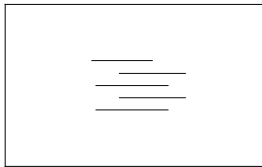
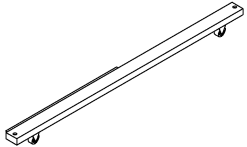
## COMPONENT LIST

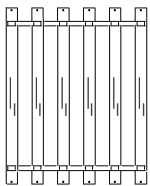
A	 <p>FRONT PANEL</p>	1 PC		H	 <p>FRONT PANEL DRAWER</p>	3 PCS
B	 <p>BACK PANEL</p>	1 PC		I	 <p>SIDE PANEL DRAWER (RIGHT)</p>	3 PCS
C	 <p>SIDE PANEL</p>	2 PCS		J	 <p>SIDE PANEL DRAWER (LEFT)</p>	3 PCS
D	 <p>SLAT SUPPORT</p>	2 PCS		K	 <p>BACK PANEL DRAWER</p>	3 PCS
E	 <p>SLAT SUPPORT WITH ROLLER (LEFT)</p>	1 PC		L	 <p>BOTTOM PANEL DRAWER</p>	3 PCS
F	 <p>SLAT SUPPORT WITH ROLLER (RIGHT)</p>	1 PC		M	 <p>RAIL SUPPORT DRAWER</p>	3 PCS
G	 <p>SLATS</p>	2 SETS				

# Step 1

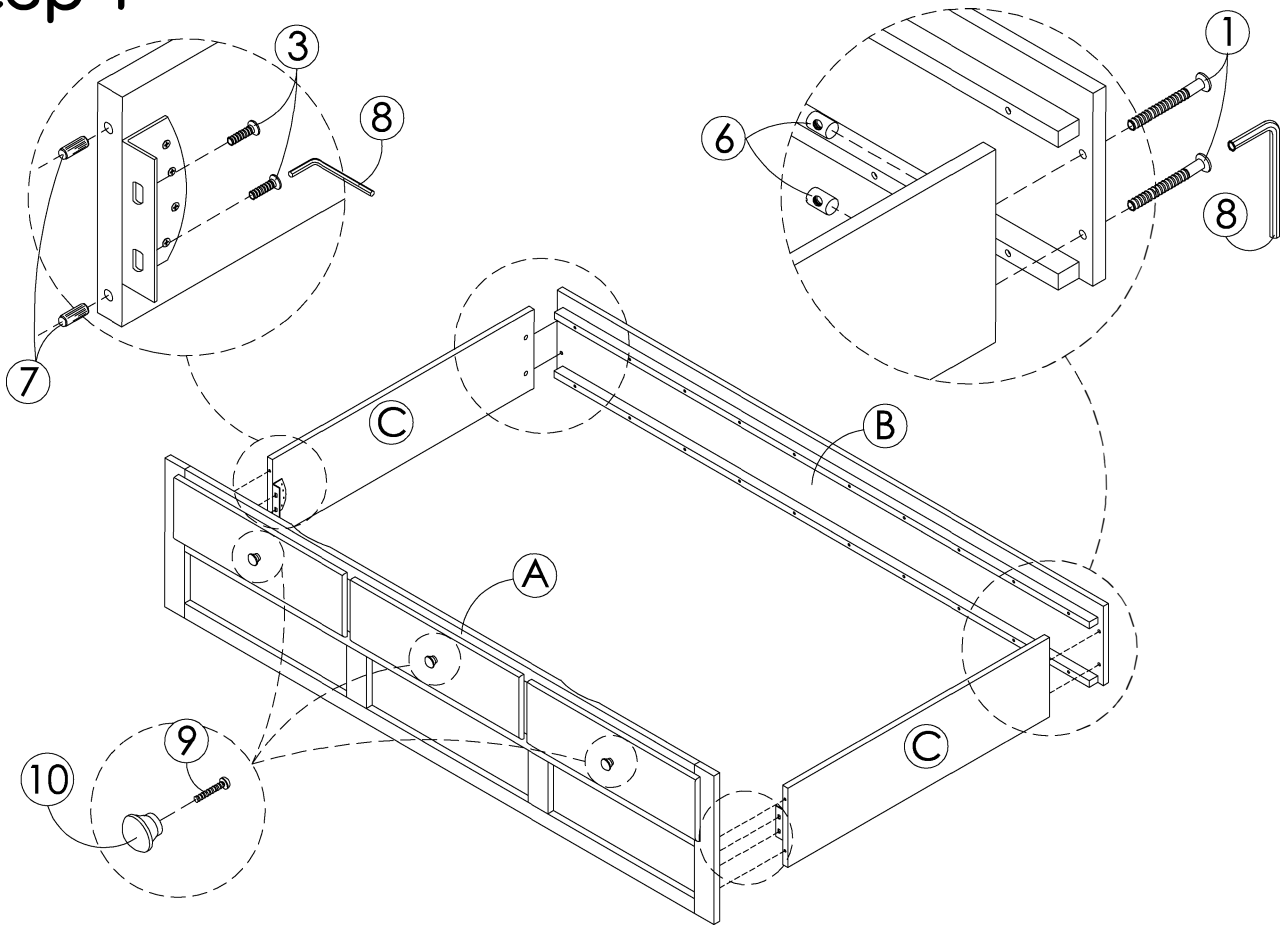

# Step 2

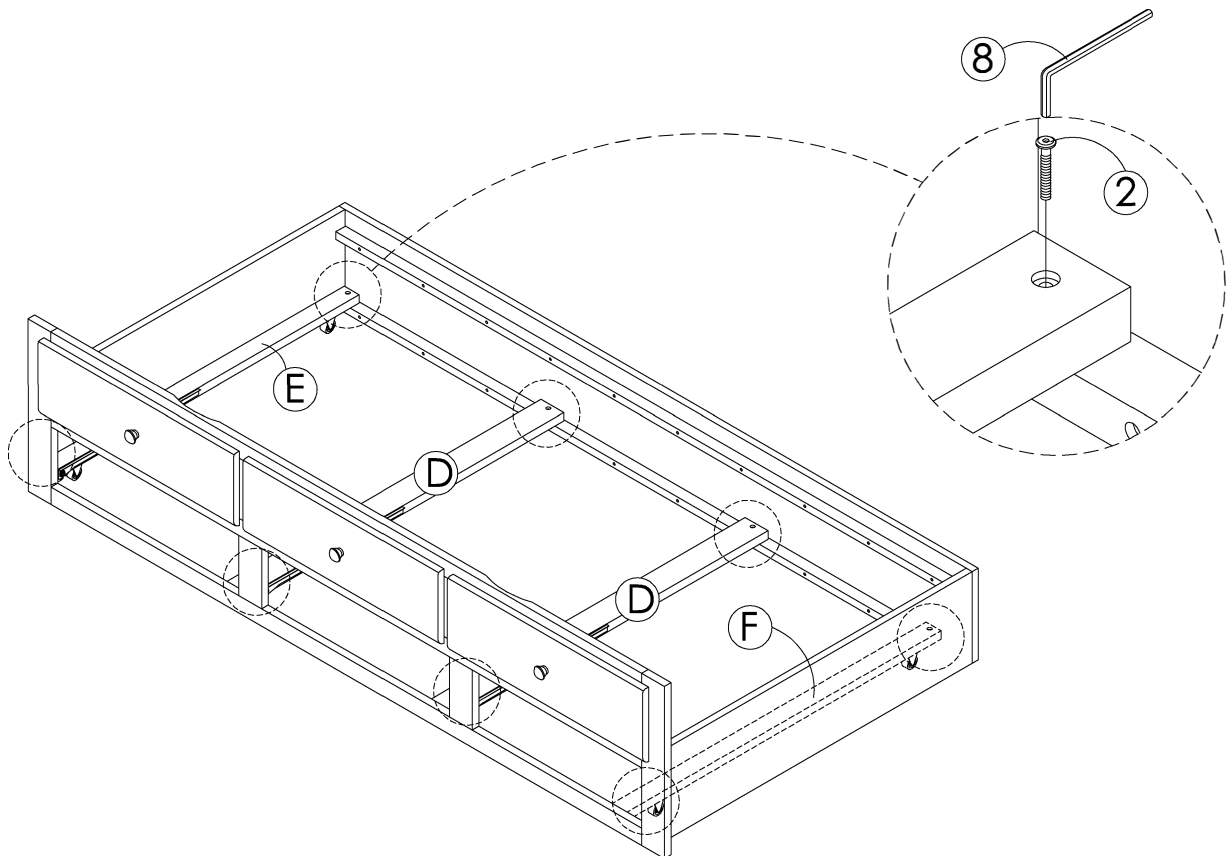

# Step 3

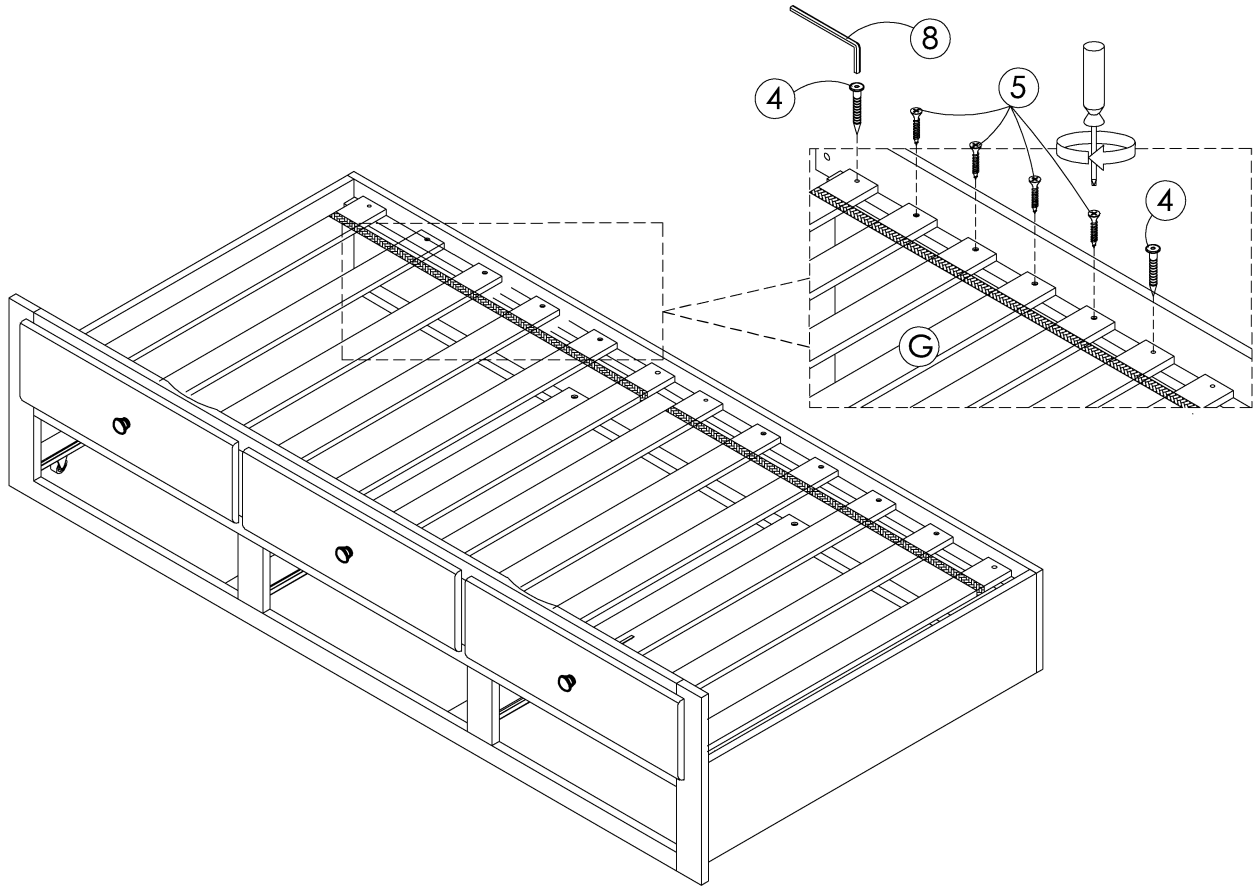

# Step 4

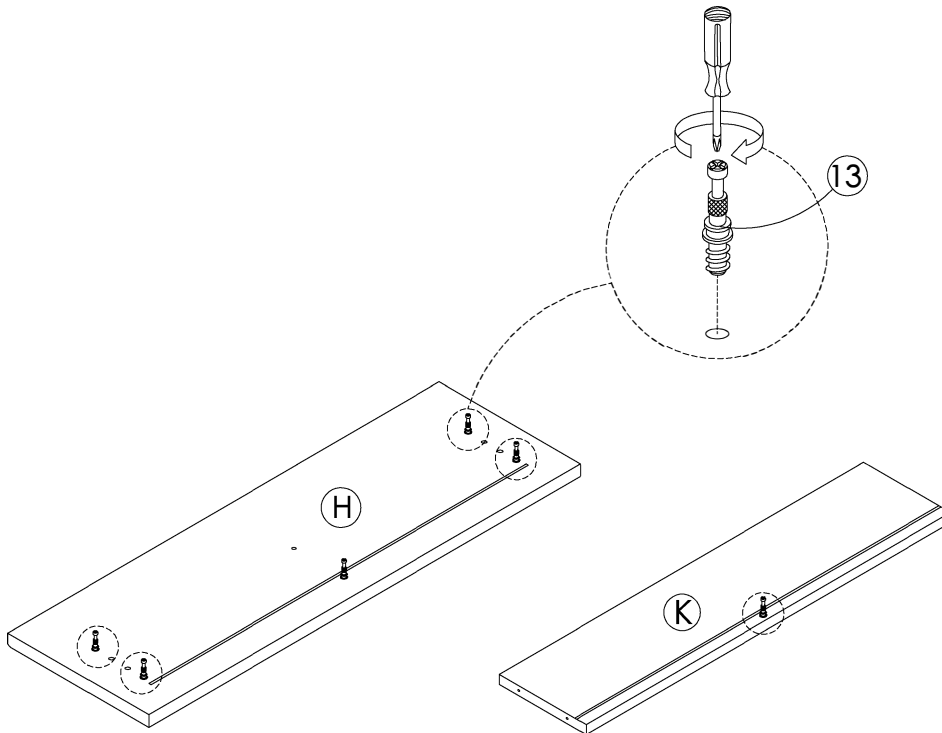

# Step 5

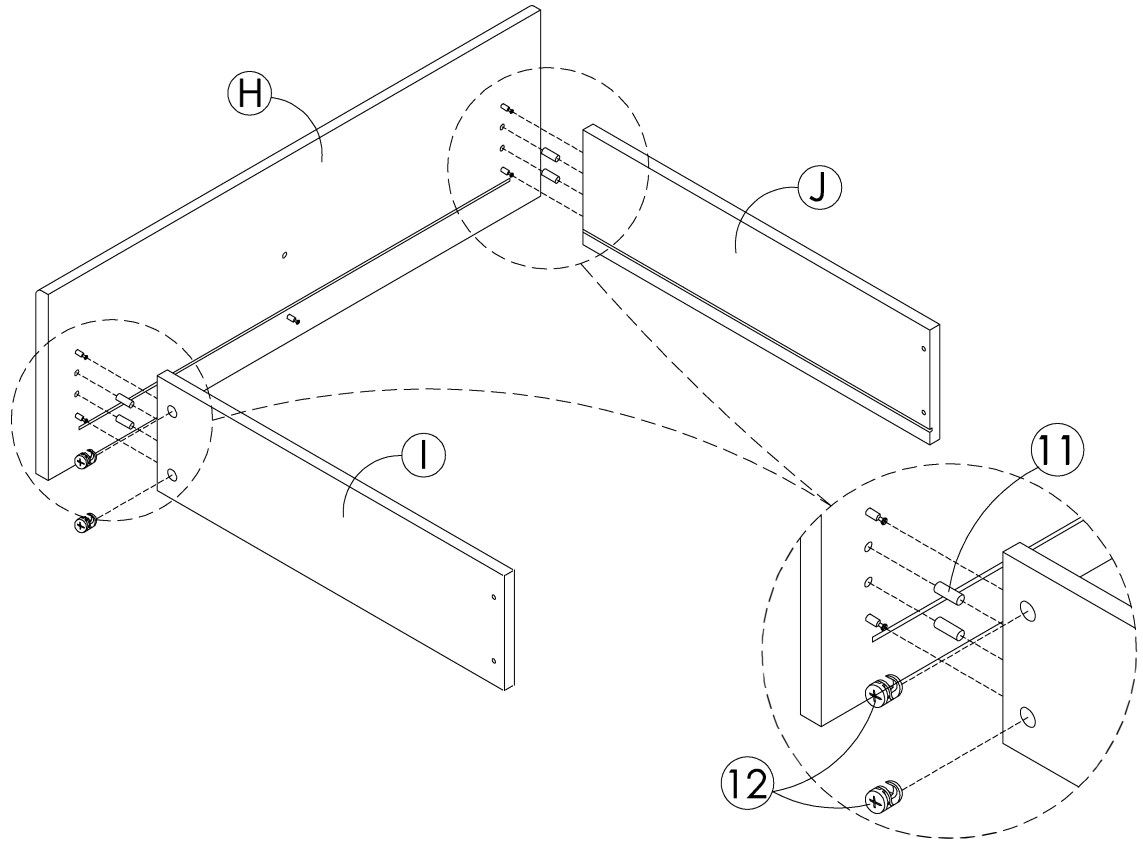

# Step 6

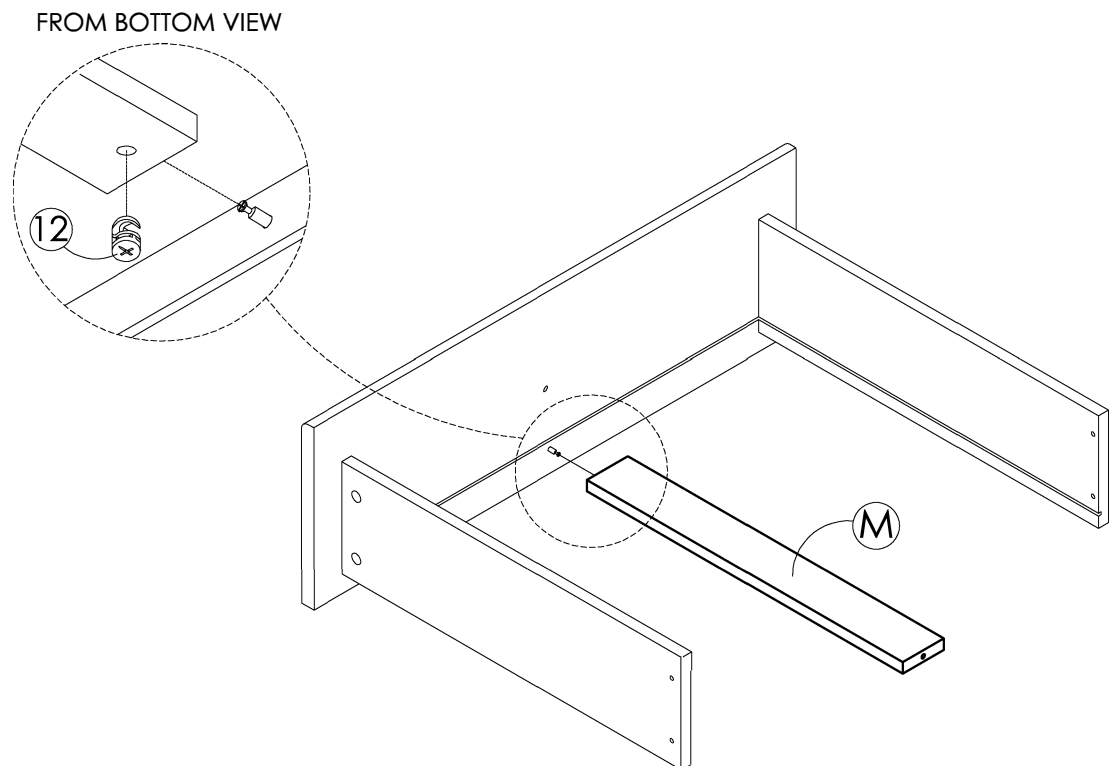

# Step 7

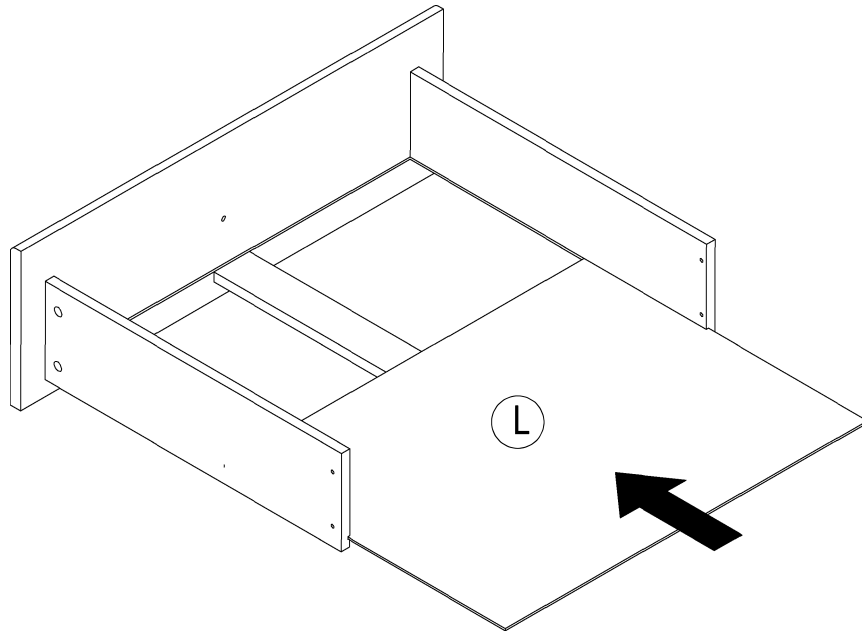

---

# Step 8

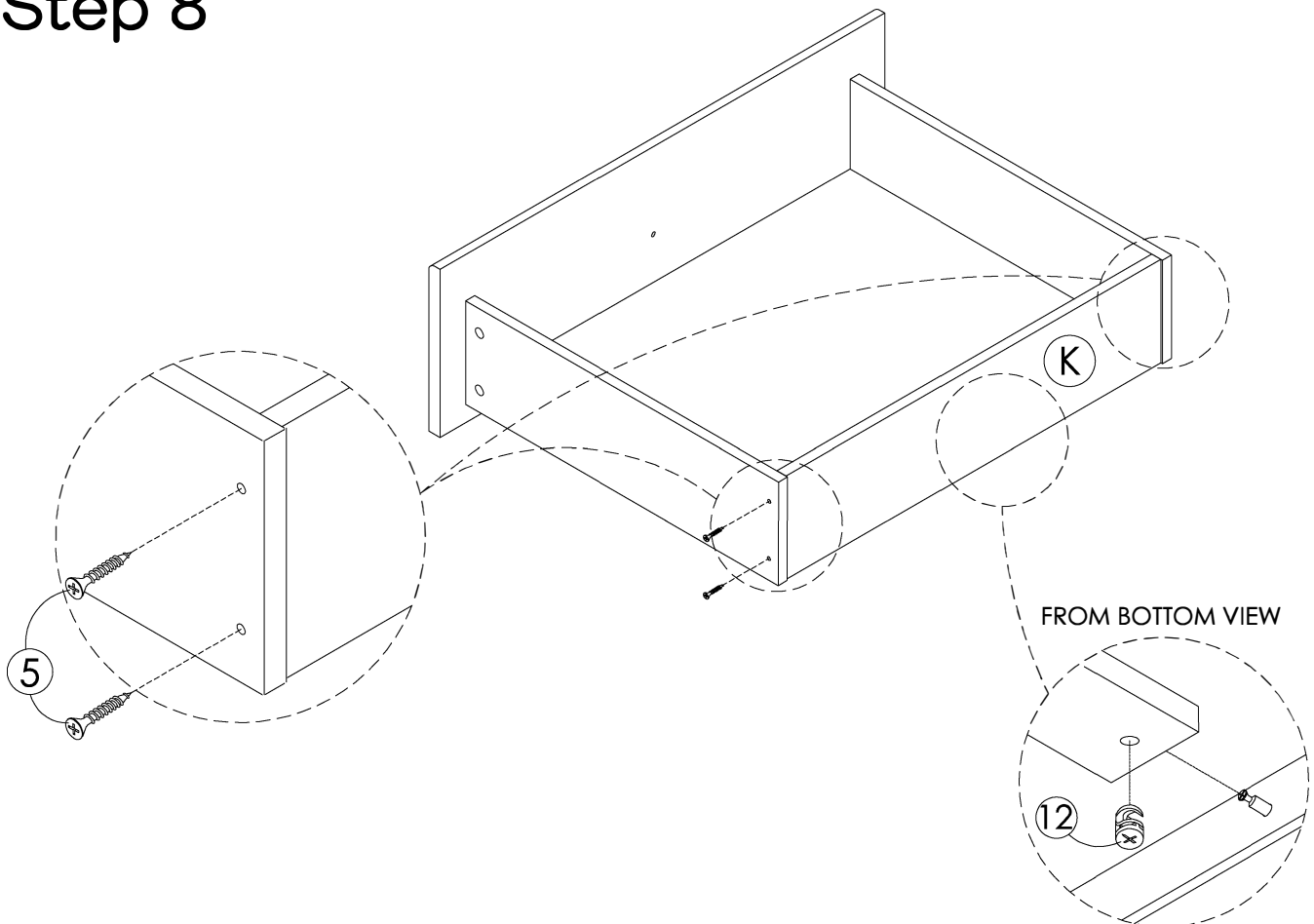

# Step 9

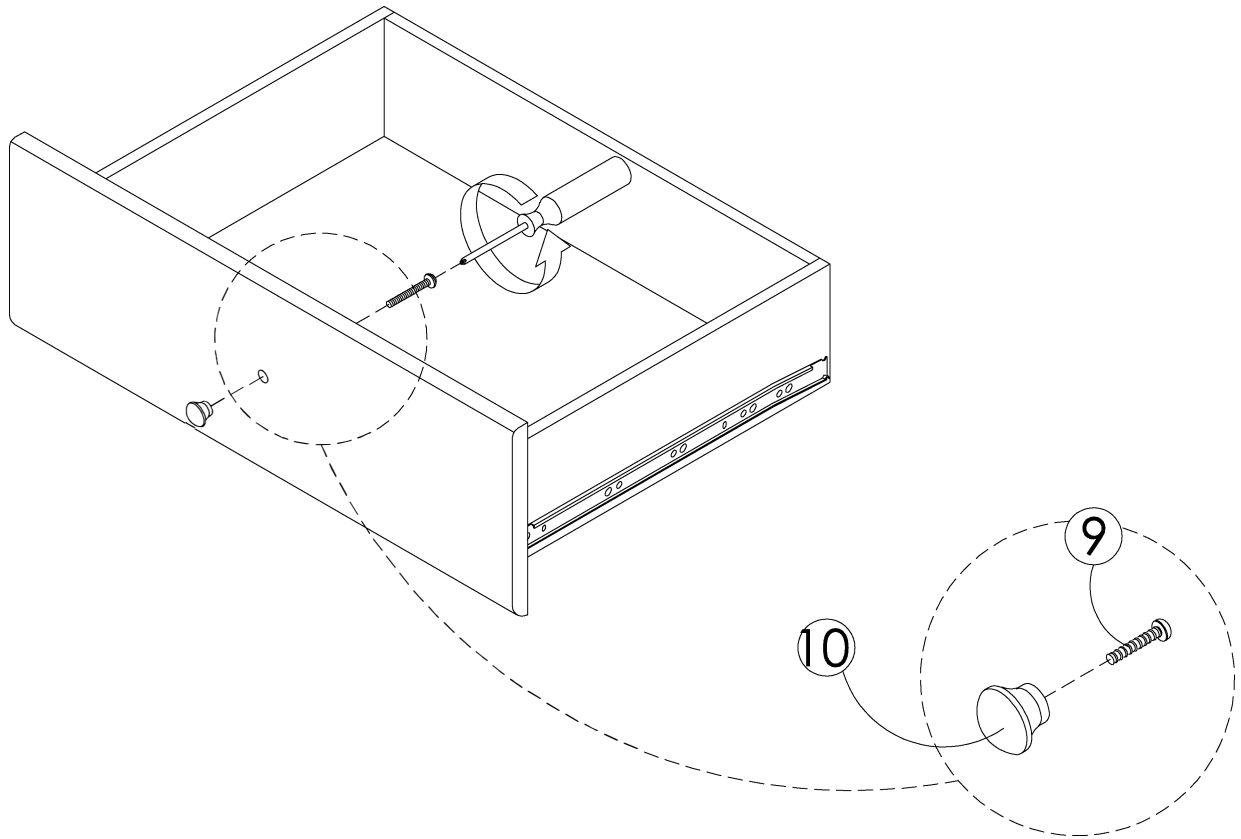

---

# STEP 10

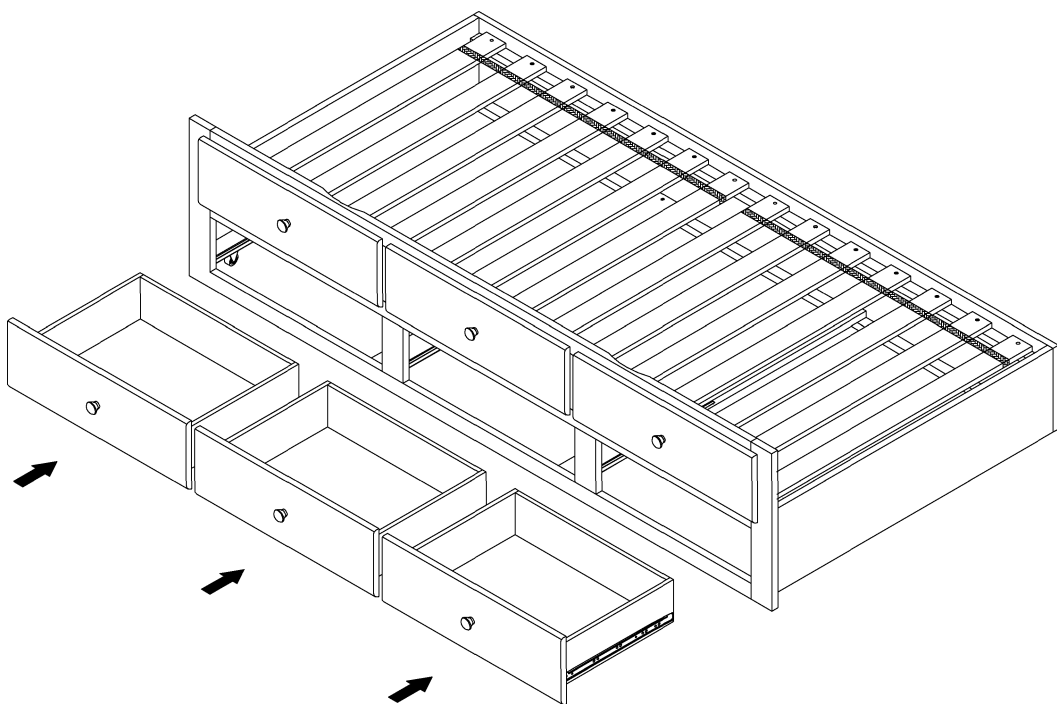

COMPLETE

