

ASSEMBLY INSTRUCTIONS

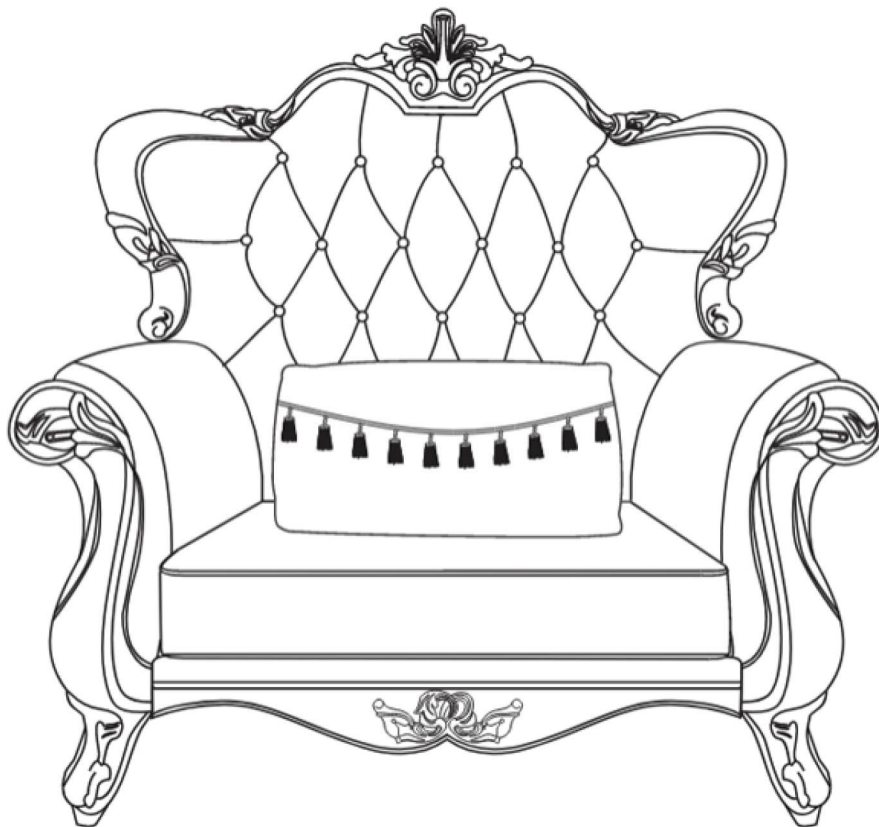

TOOLS REQUIRED



Allen Wrench
(Included)



2 - People

ASSEMBLY RATING



EASY —————> DIFFICULT

The Assembly Rating is a 5-point system showing the level of effort needed to assemble a specific product.



CHECK BEFORE STARTING

Are you missing anything?

Double-check all parts, hardware and accessories listed are all accounted for.

Check out our Quick Tips!

We recommend reviewing the pre-assembly handouts. Even experts need a refresher now and then!

Should we send any replacements?

Are there any irregularities or flaws in the parts? We can send replacements!

Prep Time!

Please review the assembly instructions and all diagrams prior to assembling.

PRE ASSEMBLY INTRODUCTION

We understand building ready-to-assemble furniture can be a challenging experience for some. To help avoid confusion, we have provided some helpful tips that may speed up the process.

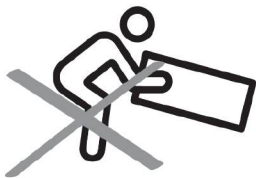

Teamwork

ALWAYS have at least two people to help with transporting and assembling the product to avoid potential injury and/or damage.

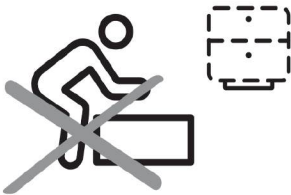

Suitable Location

Assembling near the area of the intended location is highly recommended.



Sufficient Space

Make sure you have enough space to move around during the assembly.



Avoid Scratches

Use cardboard, blankets or a carpeted area while assembling furniture to prevent to prevent scratches and damages.

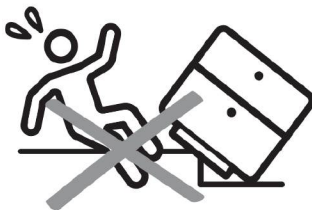

Flat Surface

Make sure the furniture rests on a flat and level surface with each leg evenly touching the floor.

ASSEMBLY AND CARE ADVICE



FAILURE TO FOLLOW THE GUIDELINES BELOW MAY RESULT IN INJURY AND/OR PROPERTY DAMAGE.



Position each part correctly and insert screws or bolts into their respective holes.

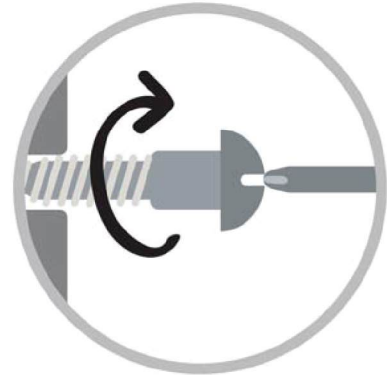

Turn clockwise to tighten and only tighten when step is completed or when instructed to do so.



Use the appropriate hand tools or power tools for assembly. Select steps, such as tightening screws and/or bolts, may require hand tools to avoid causing damage during assembly.



Save the instructions and store any supplied tools for later maintenance.

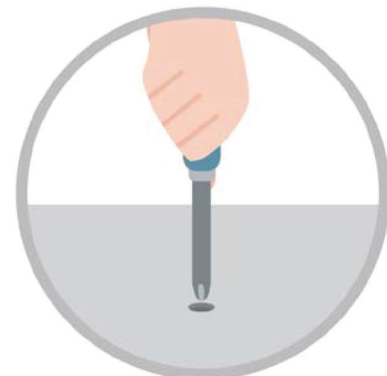

After two weeks, check and tighten any loose hardware and repeat again every six months thereafter.

IT IS THE USER'S RESPONSIBILITY TO MAINTAIN THE FURNITURE. THE HARDWARE MAY LOOSEN OVER TIME AND MAY CAUSE THE FURNITURE TO BE WOBBLY AND UNABLE TO SUPPORT ITS INTENDED WEIGHT CAPACITY. THIS MAY LEAD TO COLLAPSE AND MAY CAUSE SERIOUS INJURY.

CHAIR

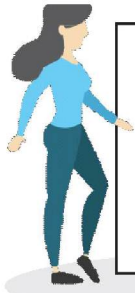

- Please keep instructions for future reference.
- Check the quantity and irregularity of parts and hardware before you start.

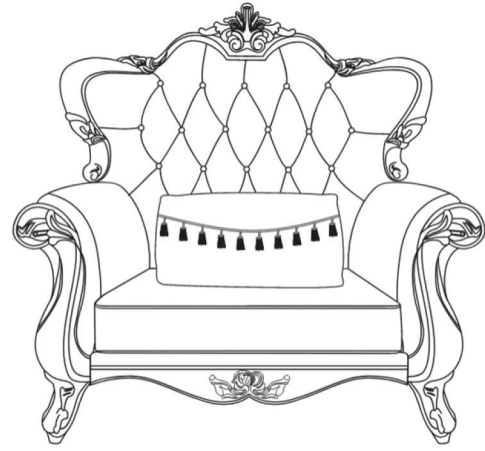

PARTS

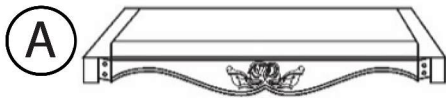

A
SEAT FRAME
1 pc.

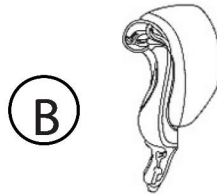

B
LEFT SIDE FACING
(LSF) ARM
1 pc.

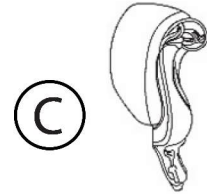

C
RIGHT SIDE FACING
(RSF) ARM
1 pc.

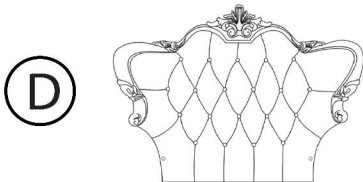

D
BACKREST
1 pc.

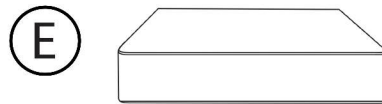

E
SEAT CUSHION
1 pc.

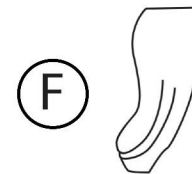

F
LEG
2 pc.

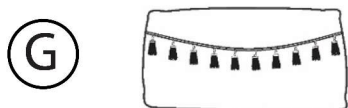

G
RECTANGLE PILLOW
1 pc.

HARDWARE

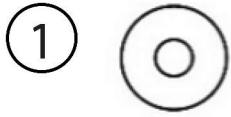

1
FLAT WASHER
Ø5/16 x 22mm
13 pc.

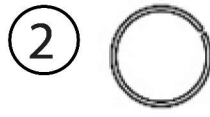

2
LOCK WASHER
Ø5/16
13 pc.



3
BOLT
Ø5/16 x 2"
6 pc.

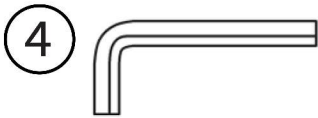

4
ALLEN KEY M5
Ø5/16"
1 pc.

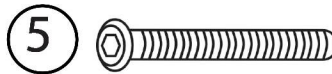

5
BOLT
Ø5/16 x 3/4"
6 pc.

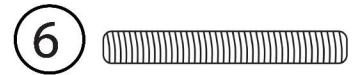

6
THREAD BOLT
Ø5/16 x 3/4"
1 pc.



7
HEX NUT
Ø5/16 x 1/2"
1 pc.



8
WRENCH
12mm
1 pc.



9
SCREWS
#4 x 70mm
4 pc.

ASSEMBLY INSTRUCTIONS

1

Align the Leg (#F) to the Seat frame (#A) and secure by using Bolts (#3) with Lock washer (#2) and Flat washer (#3).

- Part (#A) x 1pc
- Part (#F) x 2pcs
- Hardware (#1) x 4pcs
- Hardware (#2) x 4pcs
- Hardware (#3) x 4pcs
- Hardware (#4) x 1pc

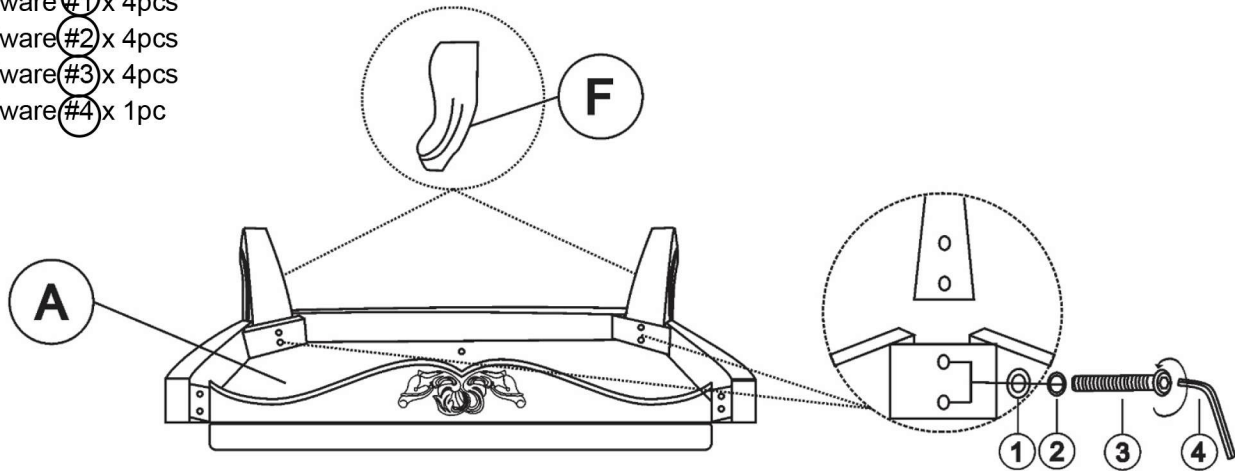

2

- Part (#B) x 1pc
- Part (#C) x 1pc
- Hardware (#1) x 6pcs
- Hardware (#2) x 6pcs
- Hardware (#5) x 6pcs

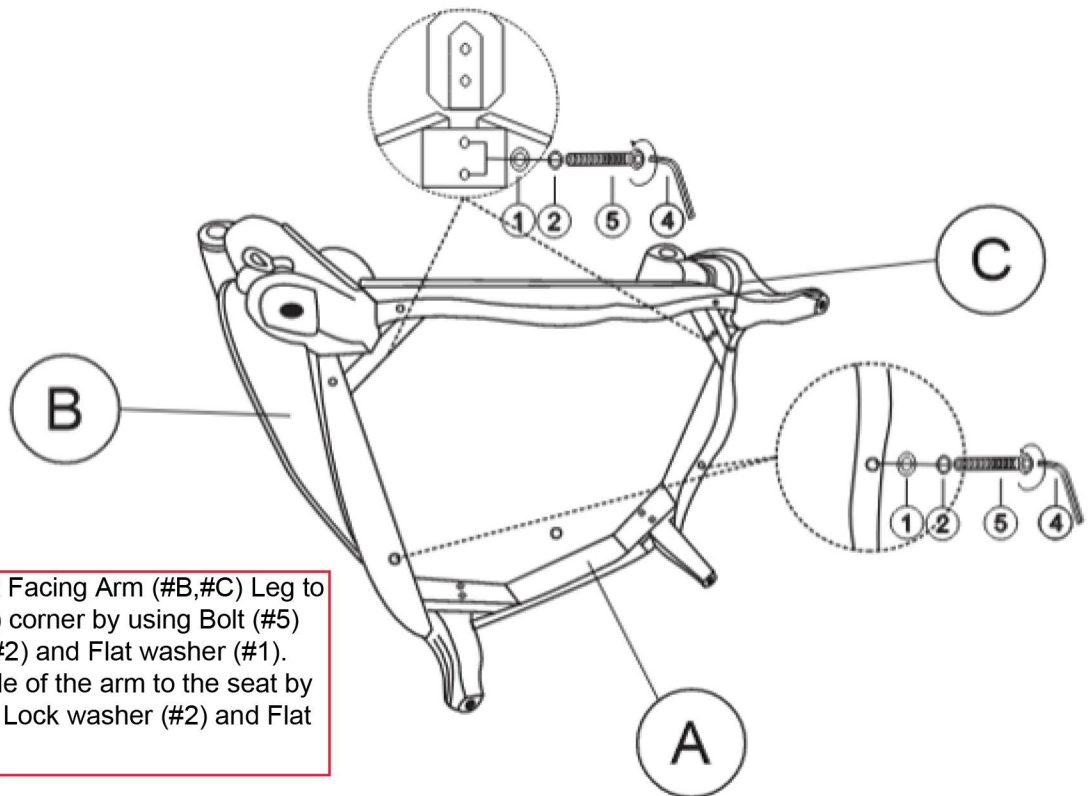

Attach the Left/right Facing Arm (#B,#C) Leg to the Seat frame (#A) corner by using Bolt (#5) with Lock washer (#2) and Flat washer (#1). Secure the back side of the arm to the seat by using Bolt (#5) with Lock washer (#2) and Flat washer (#1).

ASSEMBLY INSTRUCTIONS

Secure the arms (#B,#C) at the corner by using Screw (#9).

3

Hardware (#9) x 4pcs

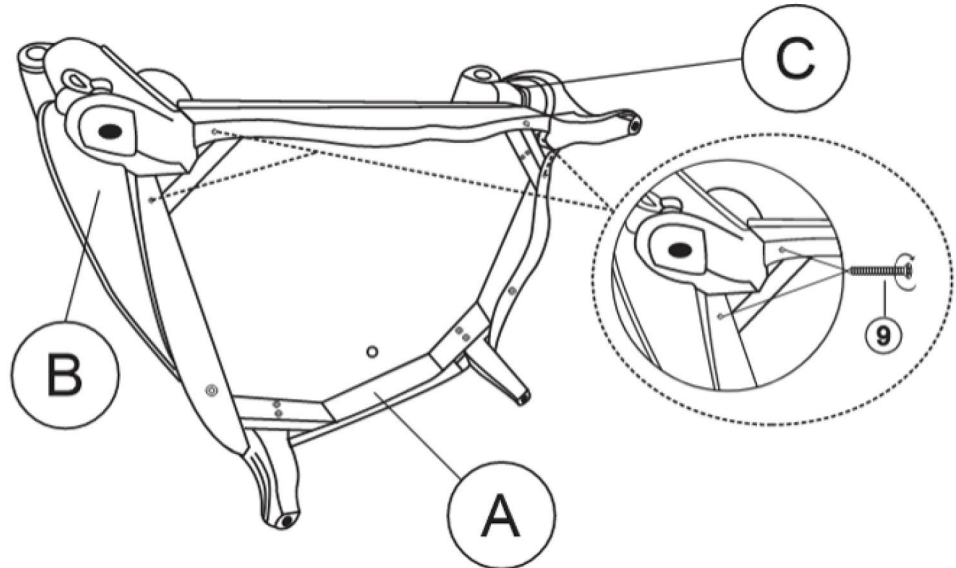

4

Part (#D) x 1pc
Hardware (#6) x 1pc

Prepare the Backrest (#D) by attaching the Threaded bolt (#6).

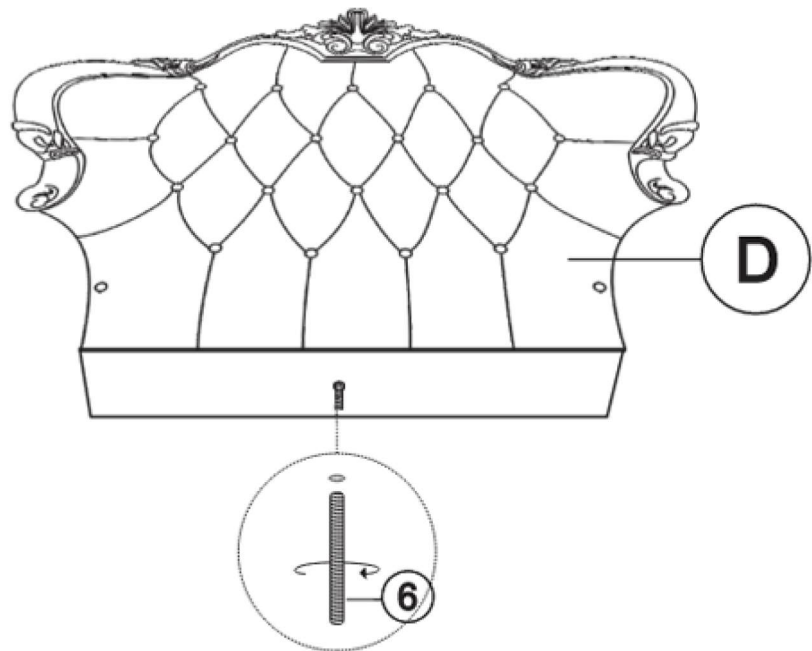

ASSEMBLY INSTRUCTIONS

5

Part #D x 1pc

Align and insert the Backrest (#D) into the Seat frame (#A).

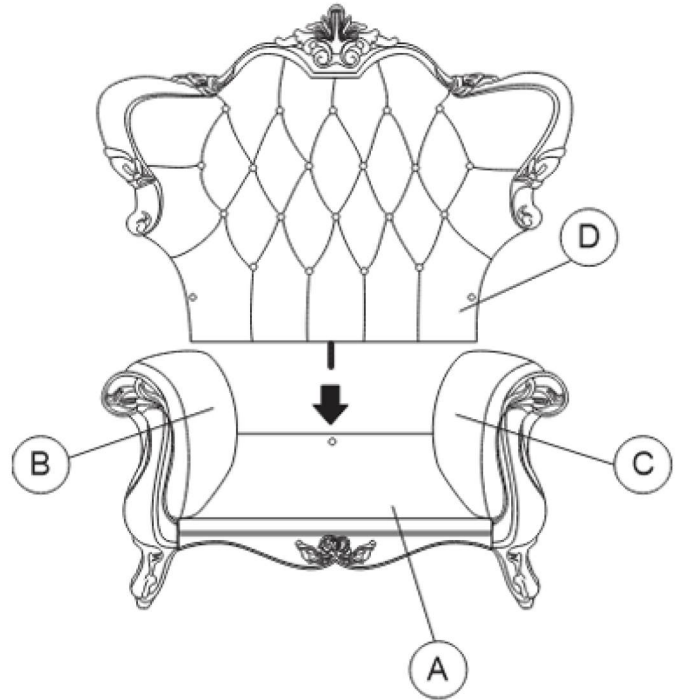

6

Hardware #1 x 2pcs

Hardware #2 x 2pcs

Hardware #3 x 2pcs

Lift Velcro and secure the Backrest (#D) to the arms by using Bolts (#3) with Lock washer (#2) with Flat washer (#1).

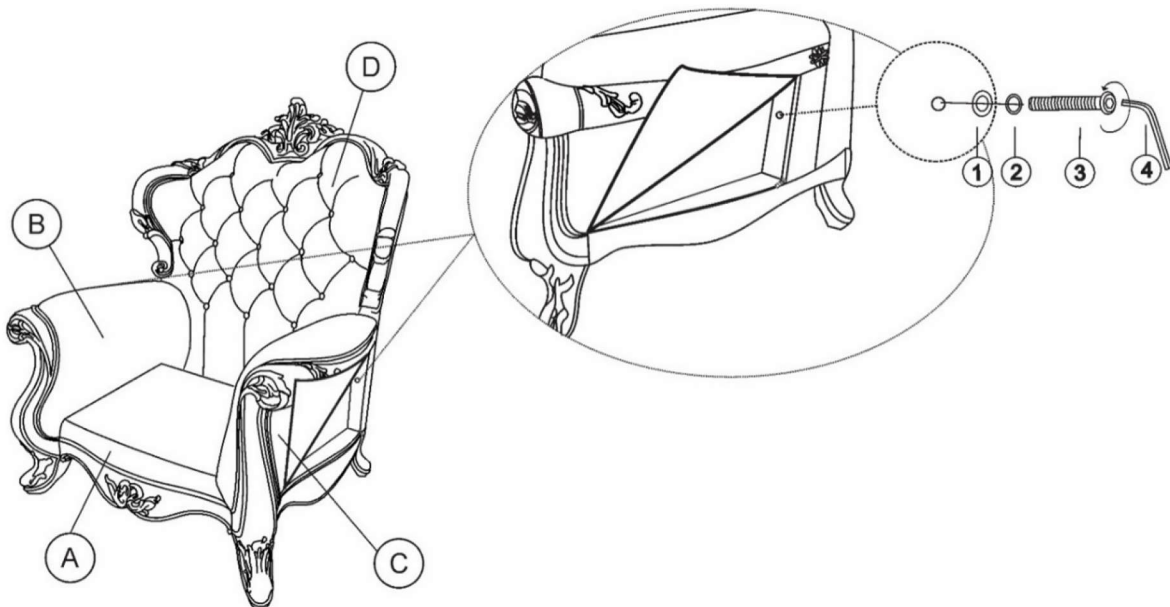

ASSEMBLY INSTRUCTIONS

7

Secure Backrest (#D) under the Seat frame (#A) by using Lock washer (#2) with Flat washer (#1).

Hardware (#1) x 1pc
Hardware (#2) x 1pc
Hardware (#7) x 1pc

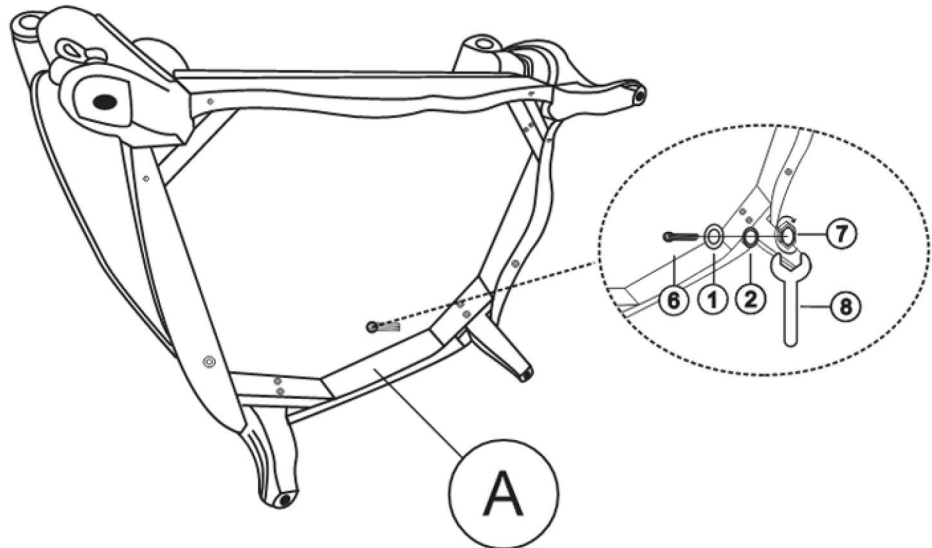

8

Part (#E) x 1pc

Place the Seat cushion (#E).

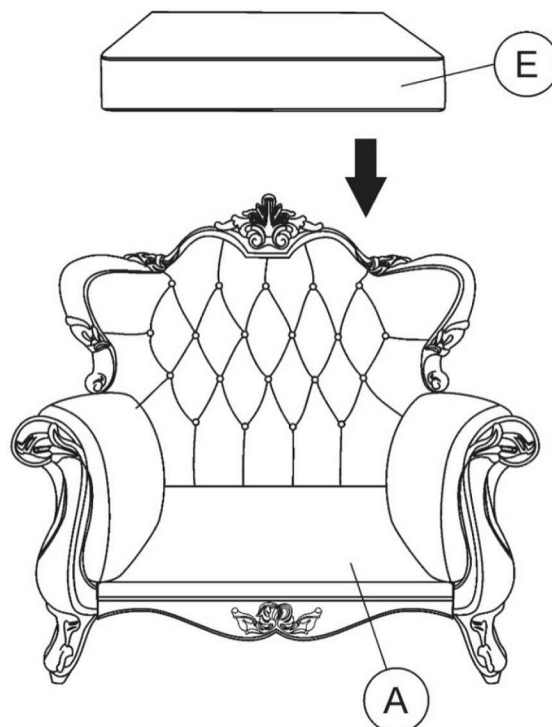

ASSEMBLY INSTRUCTIONS

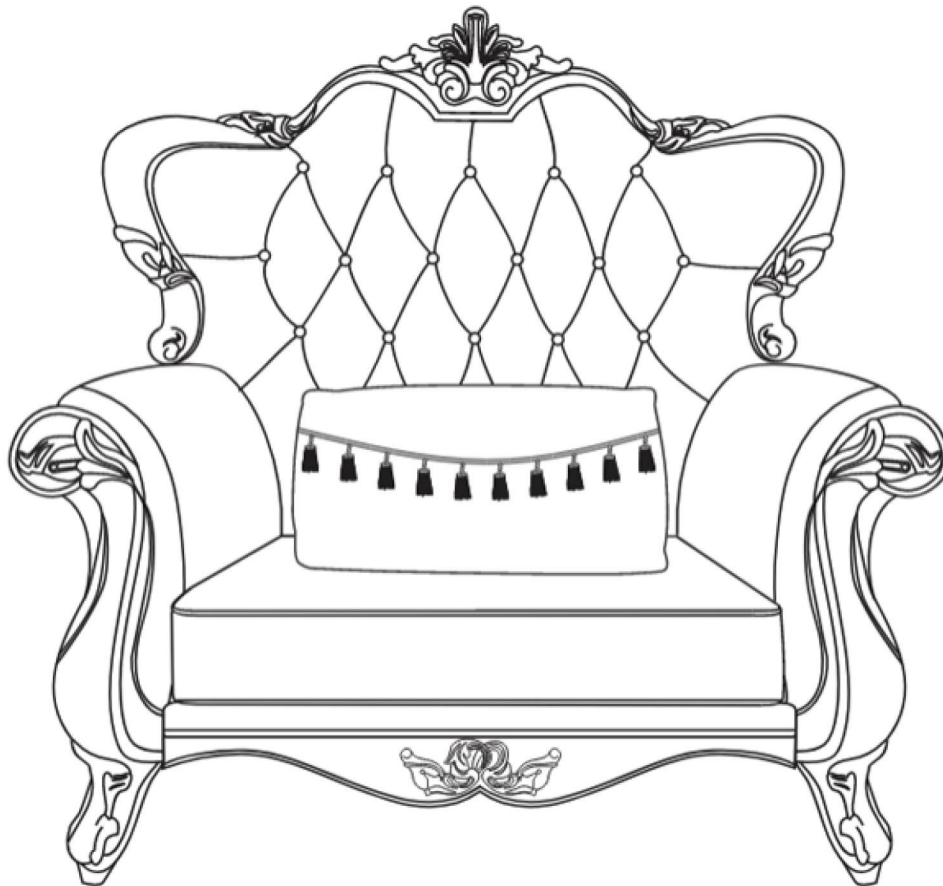

ASSEMBLY COMPLETED



Please ensure the furniture rests on an even and flat surface. If the product wobbles or feels loose, double-check all bolts and/or screws are properly tightened and secured.



Keep this handy!

Please retain this instruction manual and any order-related information for future reference.



Lift, don't drag!

To avoid damage to product please always LIFT the product when transporting or adjusting the placement.

ASSEMBLY INSTRUCTIONS

TOOLS REQUIRED



Allen Wrench
(Included)



2 - People

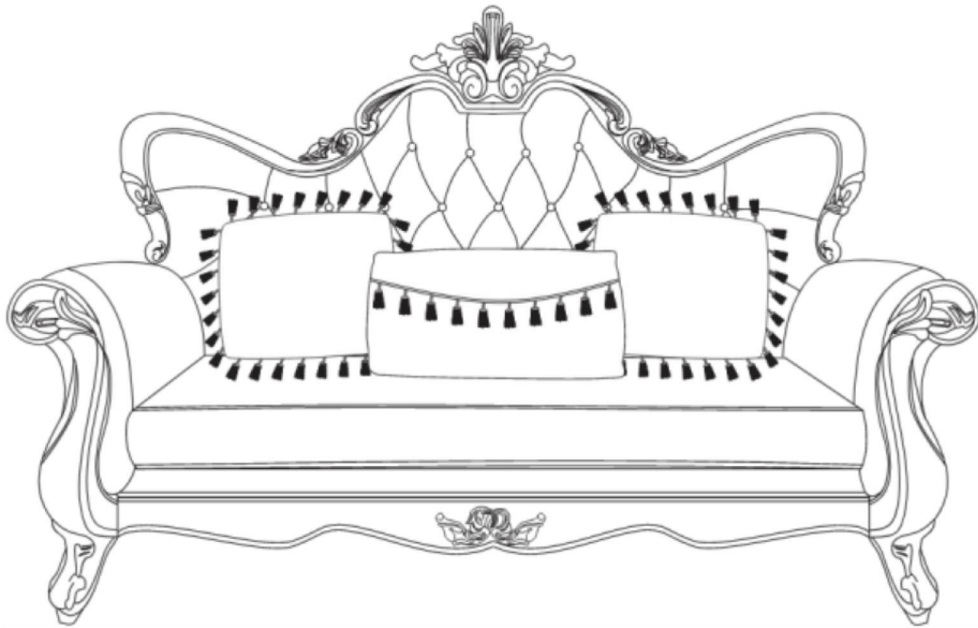

ASSEMBLY RATING



EASY —————> DIFFICULT

The Assembly Rating is a 5-point system showing the level of effort needed to assemble a specific product.



CHECK BEFORE STARTING

Are you missing anything?

Double-check all parts, hardware and accessories listed are all accounted for.

Check out our Quick Tips!

We recommend reviewing the pre-assembly handouts. Even experts need a refresher now and then!

Should we send any replacements?

Are there any irregularities or flaws in the parts? We can send replacements!

Prep Time!

Please review the assembly instructions and all diagrams prior to assembling.

PRE ASSEMBLY INTRODUCTION

We understand building ready-to-assemble furniture can be a challenging experience for some. To help avoid confusion, we have provided some helpful tips that may speed up the process.

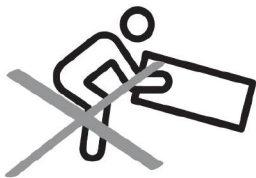

Teamwork

ALWAYS have at least two people to help with transporting and assembling the product to avoid potential injury and/or damage.

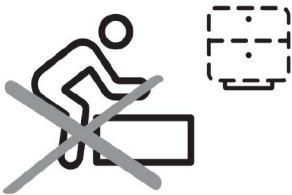

Suitable Location

Assembling near the area of the intended location is highly recommended.



Sufficient Space

Make sure you have enough space to move around during the assembly.



Avoid Scratches

Use cardboard, blankets or a carpeted area while assembling furniture to prevent to prevent scratches and damages.



Flat Surface

Make sure the furniture rests on a flat and level surface with each leg evenly touching the floor.

ASSEMBLY AND CARE ADVICE



FAILURE TO FOLLOW THE GUIDELINES BELOW MAY RESULT IN INJURY AND/OR PROPERTY DAMAGE.



Position each part correctly and insert screws or bolts into their respective holes.

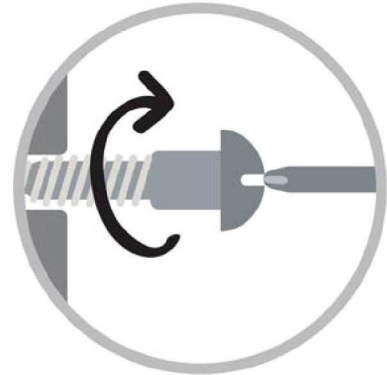

Turn clockwise to tighten and only tighten when step is completed or when instructed to do so.



Use the appropriate hand tools or power tools for assembly. Select steps, such as tightening screws and/or bolts, may require hand tools to avoid causing damage during assembly.



Save the instructions and store any supplied tools for later maintenance.

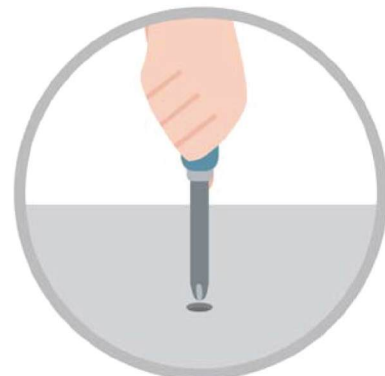

After two weeks, check and tighten any loose hardware and repeat again every six months thereafter.

IT IS THE USER'S RESPONSIBILITY TO MAINTAIN THE FURNITURE. THE HARDWARE MAY LOOSEN OVER TIME AND MAY CAUSE THE FURNITURE TO BE WOBBLY AND UNABLE TO SUPPORT ITS INTENDED WEIGHT CAPACITY. THIS MAY LEAD TO COLLAPSE AND MAY CAUSE SERIOUS INJURY.

LOVESEAT

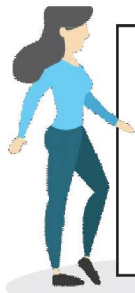

- Please keep instructions for future reference.
- Check the quantity and irregularity of parts and hardware before you start.

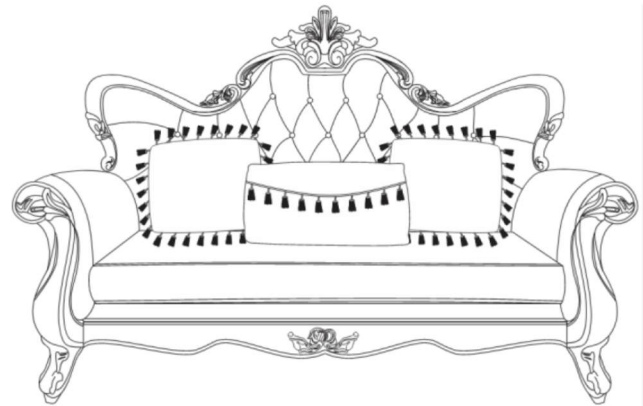

PARTS

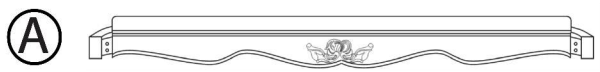

SEAT FRAME

1 pc.

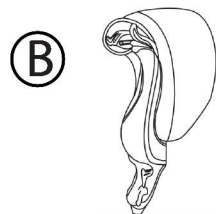

LEFT SIDE FACING
(LSF) ARM

1 pc.

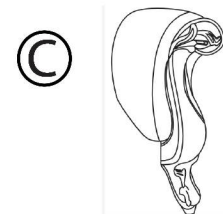

RIGHT SIDE FACING
(RSF) ARM

1 pc.

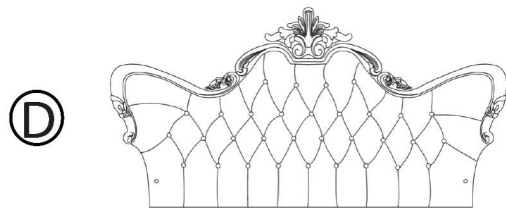

BACKREST

1 pc.



SEAT CUSHION

1 pc.

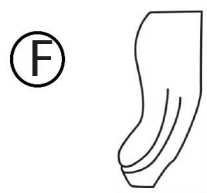

LEG

2 pc.



RECTANGLE PILLOW

1 pc.

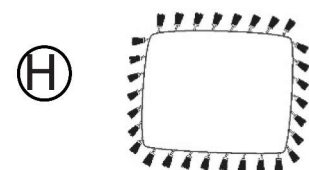

BIG SQUARE PILLOW

2 pc.

HARDWARE

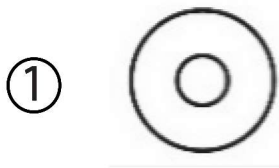

①

FLAT WASHER
Ø5/16 x 22mm

14 pc.

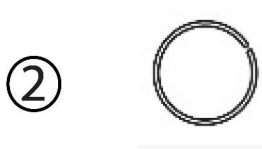

②

LOCK WASHER
Ø5/16

14 pc.

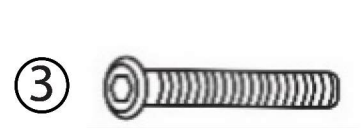

③

BOLT
Ø5/16 x 2"

6 pc.

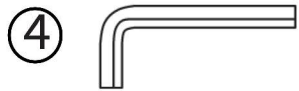

④

ALLEN KEY M5
Ø5/16

1 pc.



⑤

BOLT
Ø5/16 x 3¼"

6 pc.

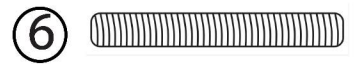

⑥

THREAD BOLT
Ø5/16 x 3¼"

2 pc.



⑦

HEX NUT
Ø5/16 x 1/2"

2 pc.



⑧

WRENCH
12mm

1 pc.

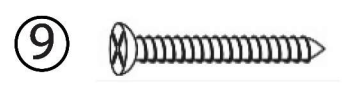

⑨

SCREWS
#4 x 70mm

4 pc.

ASSEMBLY INSTRUCTIONS

1

- Part (#A) x 1pc
- Part (#F) x 2pcs
- Hardware (#1) x 4pcs
- Hardware (#2) x 4pcs
- Hardware (#3) x 4pcs
- Hardware (#4) x 1pc

Align the Leg (#F) to the Seat frame (#A) and secure by using Bolts (#3) with Lock washer (#2) and Flat washer (#3).

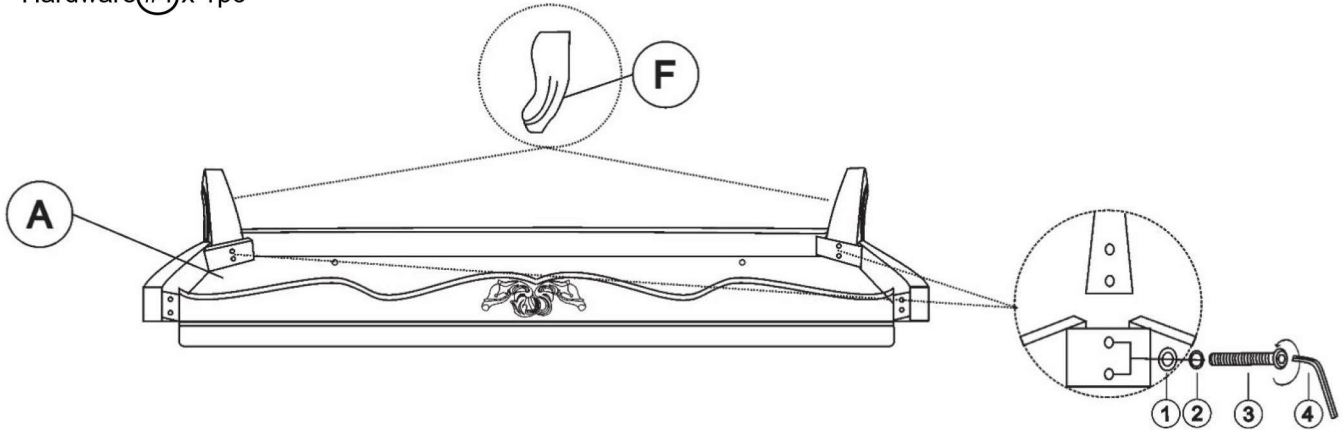

2

- Part (#B) x 1pc
- Part (#C) x 1pc
- Hardware (#1) x 6pcs
- Hardware (#2) x 6pcs
- Hardware (#5) x 6pcs

Attach the Left/right Facing Arm (#B,#C) Leg to the Seat frame (#A) corner by using Bolt (#5) with Lock washer (#2) and Flat washer (#1). Secure the back side of the arm to the seat by using Bolt (#5) with Lock washer (#2) and Flat washer (#1).

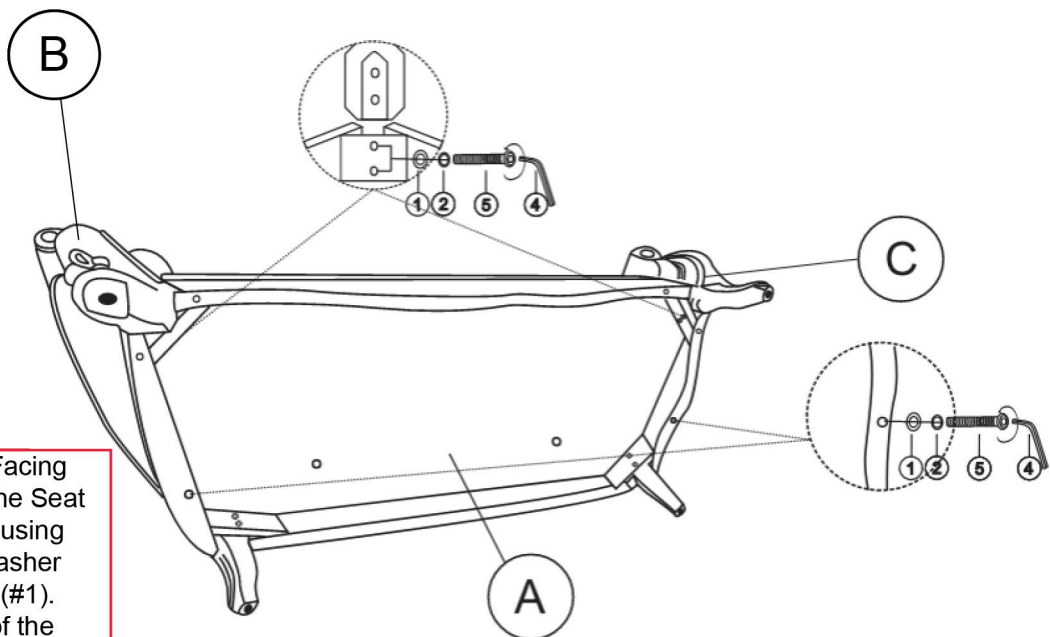

ASSEMBLY INSTRUCTIONS

3

Hardware #9 x 4pcs

Secure the arms (#B,#C) at the corner by using Screw (#9).

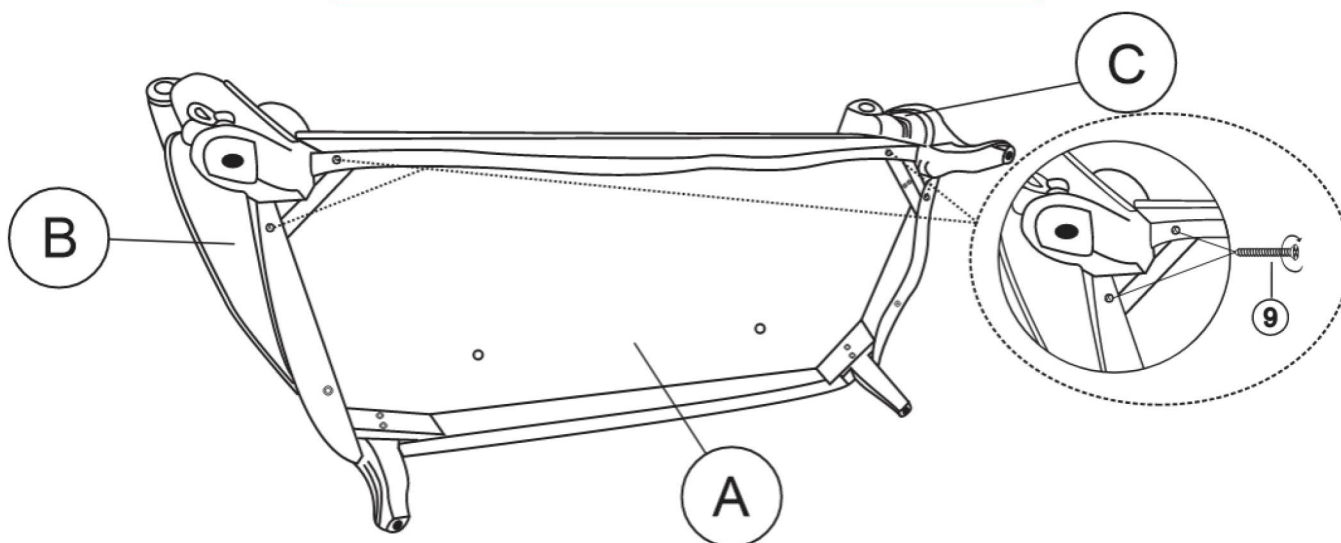

4

Part #D x 1pc
Hardware #6 x 2pcs

Prepare the Backrest (#D) by attaching the Threaded bolt (#6).

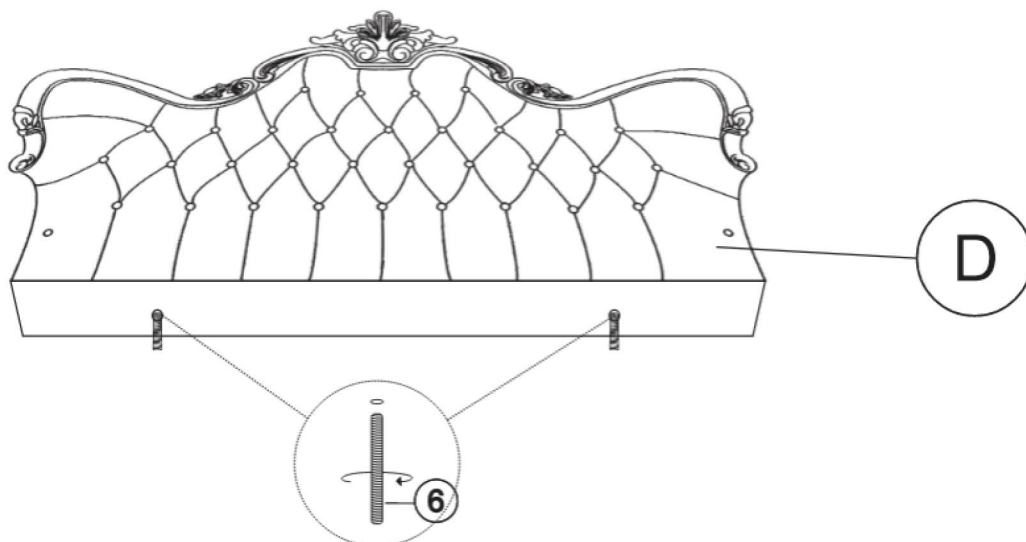

ASSEMBLY INSTRUCTIONS

5

Align and insert the Backrest (#D) into the Seat frame (#A).

Part #D x 1pc

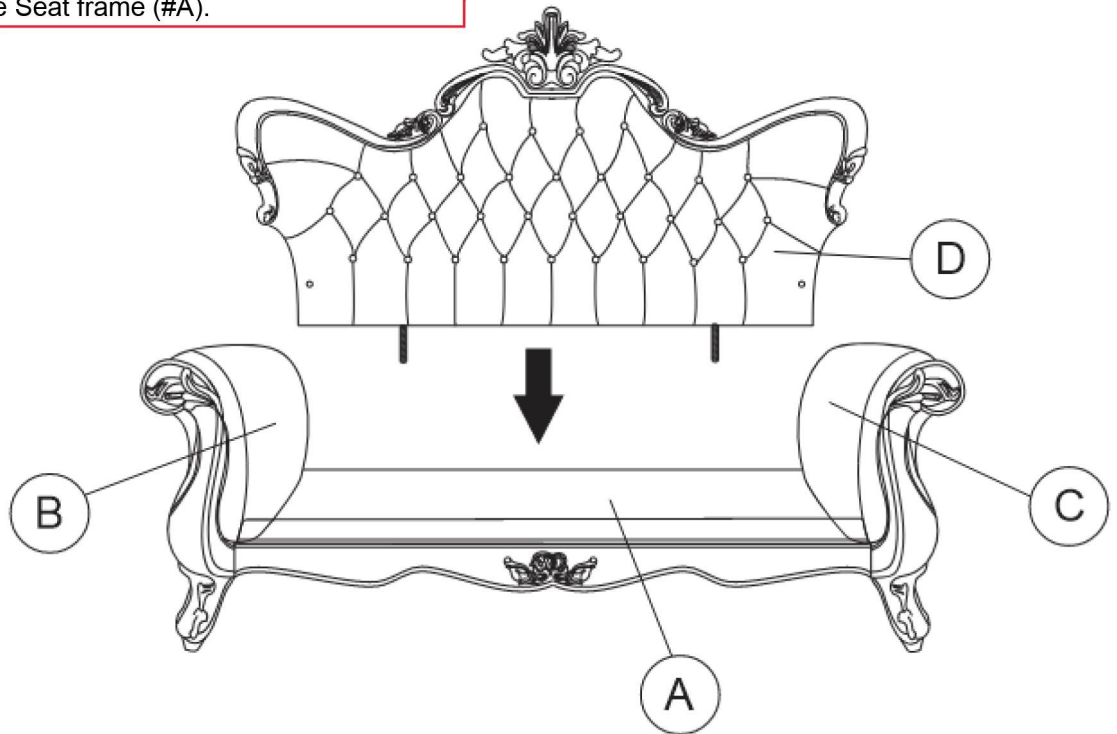

6

Lift Velcro and secure the Backrest (#D) to the arms by using Bolts (#3) with Lock washer (#2) with Flat washer (#1).

Hardware #1 x 2pcs

Hardware #2 x 2pcs

Hardware #3 x 2pcs

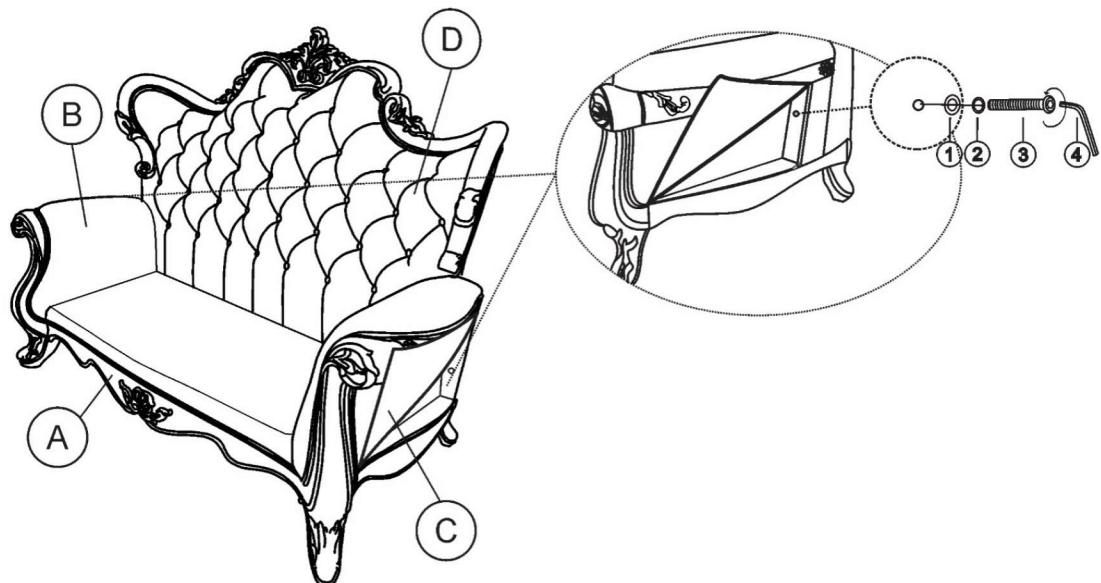

ASSEMBLY INSTRUCTIONS

7

Hardware #1 x 2pcs

Hardware #2 x 2pcs

Hardware #7 x 2pcs

Secure Backrest (#D) under the Seat frame (#A) by using Lock washer (#2) with Flat washer (#1).

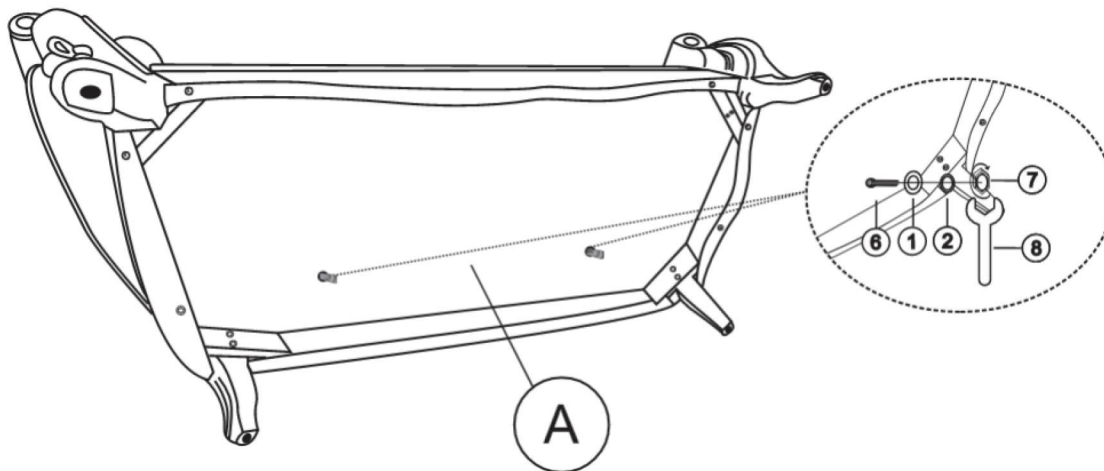

8

Part #E x 1pc

Place the Seat cushion (#E).

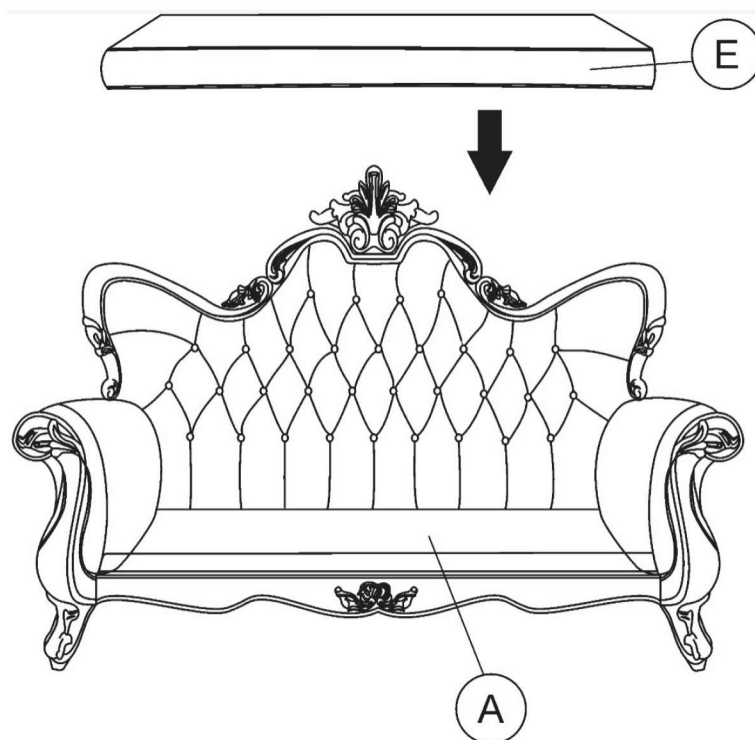

ASSEMBLY INSTRUCTIONS

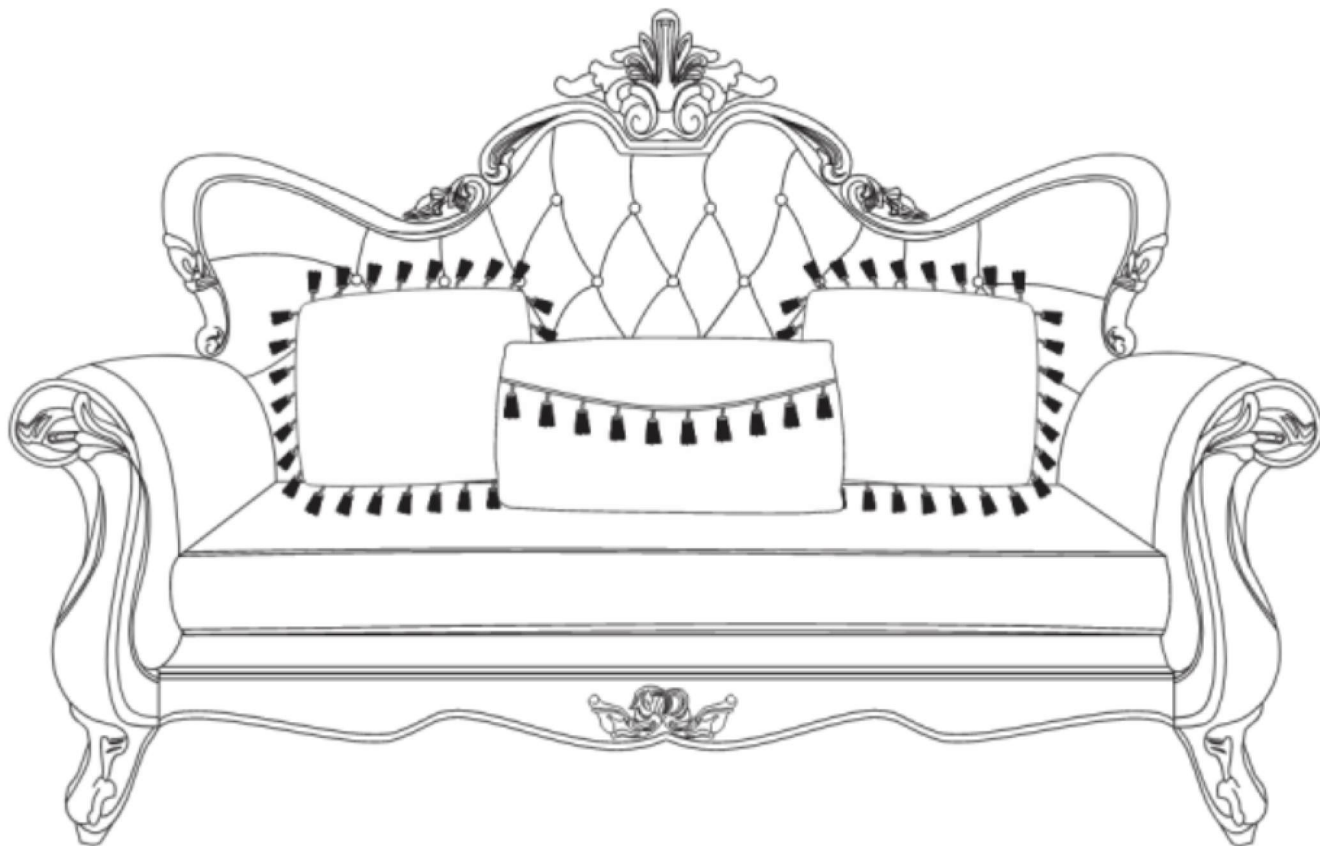

ASSEMBLY COMPLETED



Please ensure the furniture rests on an even and flat surface. If the product wobbles or feels loose, double-check all bolts and/or screws are properly tightened and secured.

✓ **Keep this handy!**

Please retain this instruction manual and any order-related information for future reference.

✓ **Lift, don't drag!**

To avoid damage to product please always LIFT the product when transporting or adjusting the placement.

ASSEMBLY INSTRUCTIONS

TOOLS REQUIRED



Allen Wrench
(Included)



2 - People

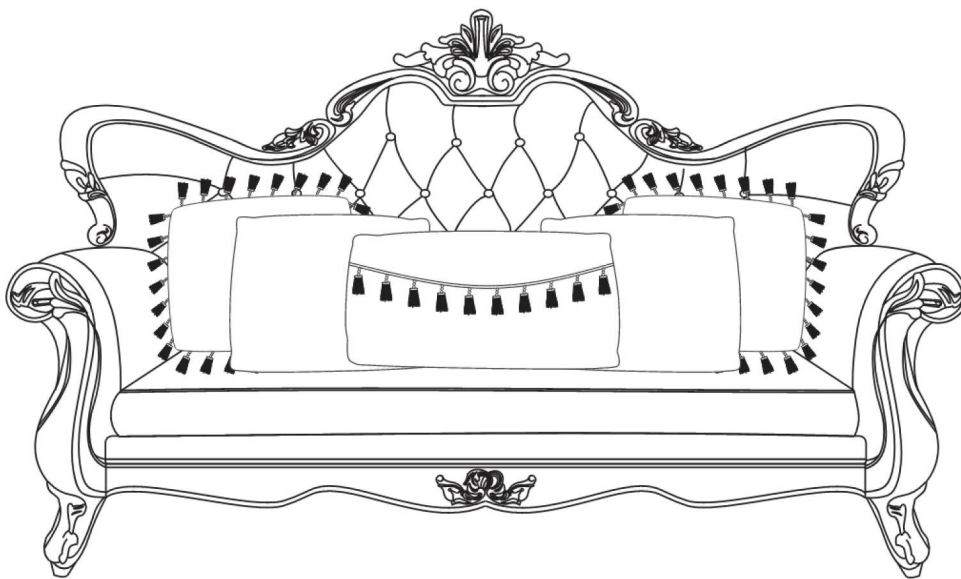

ASSEMBLY RATING



EASY —————> DIFFICULT

The Assembly Rating is a 5-point system showing the level of effort needed to assemble a specific product.



CHECK BEFORE STARTING

Are you missing anything?

Double-check all parts, hardware and accessories listed are all accounted for.

Check out our Quick Tips!

We recommend reviewing the pre-assembly handouts. Even experts need a refresher now and then!

Should we send any replacements?

Are there any irregularities or flaws in the parts? We can send replacements!

Prep Time!

Please review the assembly instructions and all diagrams prior to assembling.

PRE ASSEMBLY INTRODUCTION

We understand building ready-to-assemble furniture can be a challenging experience for some. To help avoid confusion, we have provided some helpful tips that may speed up the process.

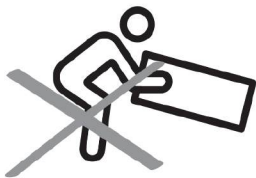

Teamwork

ALWAYS have at least two people to help with transporting and assembling the product to avoid potential injury and/or damage.

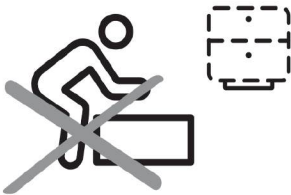

Suitable Location

Assembling near the area of the intended location is highly recommended.



Sufficient Space

Make sure you have enough space to move around during the assembly.



Avoid Scratches

Use cardboard, blankets or a carpeted area while assembling furniture to prevent to prevent scratches and damages.



Flat Surface

Make sure the furniture rests on a flat and level surface with each leg evenly touching the floor.

ASSEMBLY AND CARE ADVICE



FAILURE TO FOLLOW THE GUIDELINES BELOW MAY RESULT IN INJURY AND/OR PROPERTY DAMAGE.



Position each part correctly and insert screws or bolts into their respective holes.

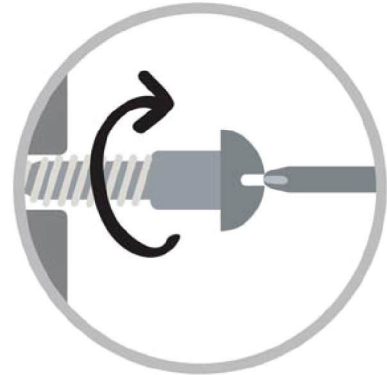

Turn clockwise to tighten and only tighten when step is completed or when instructed to do so.



Use the appropriate hand tools or power tools for assembly. Select steps, such as tightening screws and/or bolts, may require hand tools to avoid causing damage during assembly.



Save the instructions and store any supplied tools for later maintenance.

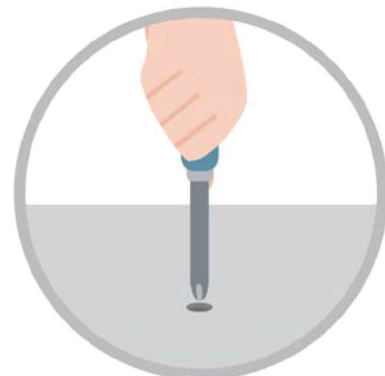

After two weeks, check and tighten any loose hardware and repeat again every six months thereafter.

IT IS THE USER'S RESPONSIBILITY TO MAINTAIN THE FURNITURE. THE HARDWARE MAY LOOSEN OVER TIME AND MAY CAUSE THE FURNITURE TO BE WOBBLY AND UNABLE TO SUPPORT ITS INTENDED WEIGHT CAPACITY. THIS MAY LEAD TO COLLAPSE AND MAY CAUSE SERIOUS INJURY.

SOFA

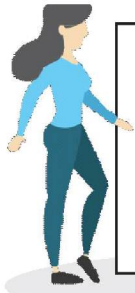

- Please keep instructions for future reference.
- Check the quantity and irregularity of parts and hardware before you start.

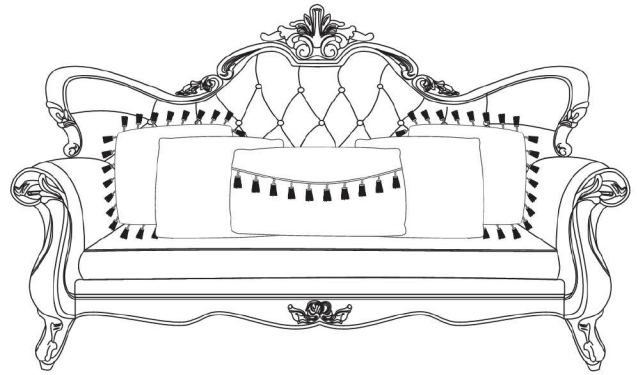

PARTS



SEAT FRAME

1 pc.

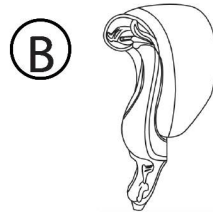

LEFT SIDE FACING
(LSF) ARM

1 pc.

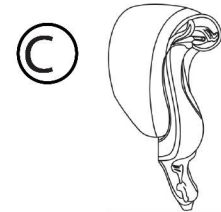

RIGHT SIDE FACING
(RSF) ARM

1 pc.

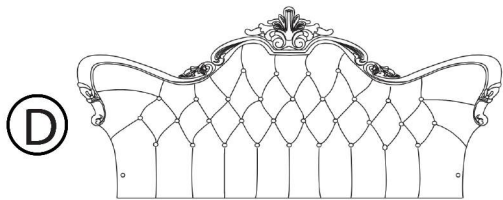

BACKREST

1 pc.

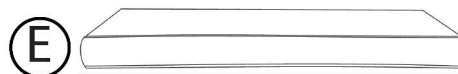

SEAT CUSHION

1 pc.

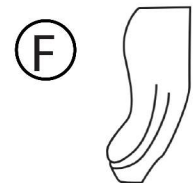

LEG

2 pc.



RECTANGLE
PILLOW

1 pc.

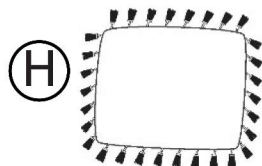

BIG SQUARE
PILLOW

2 pc.

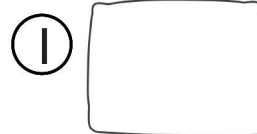

SQUARE
PILLOW

2 pc.

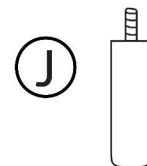

SUPPORT
LEG

1 pc.

HARDWARE

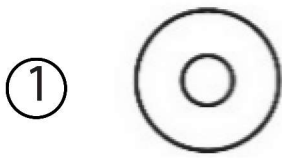

①

FLAT WASHER
Ø5/16 x 22mm

14 pc.



②

LOCK WASHER
Ø5/16

14 pc.

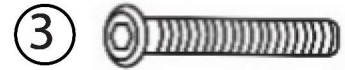

③

BOLT
Ø5/16 x 2"

6 pc.

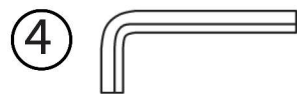

④

ALLEN KEY M5
Ø5/16

1 pc.

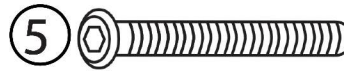

⑤

BOLT
Ø5/16 x 3¼"

6 pc.

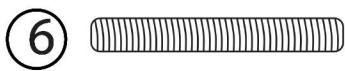

⑥

THREAD BOLT
Ø5/16 x 3¼"

2 pc.



⑦

HEX NUT
Ø5/16 x 1/2"

2 pc.



⑧

WRENCH
12mm

1 pc.



⑨

SCREWS
#4 x 70mm

4 pc.

ASSEMBLY INSTRUCTIONS

1

Align the Leg (#F) to the Seat frame (#A) and secure by using Bolts (#3) with Lock washer (#2) and Flat washer (#3).

- Part #A x 1pc
- Part #F x 2pcs
- Hardware #1 x 4pcs
- Hardware #2 x 4pcs
- Hardware #3 x 4pcs
- Hardware #4 x 1pc

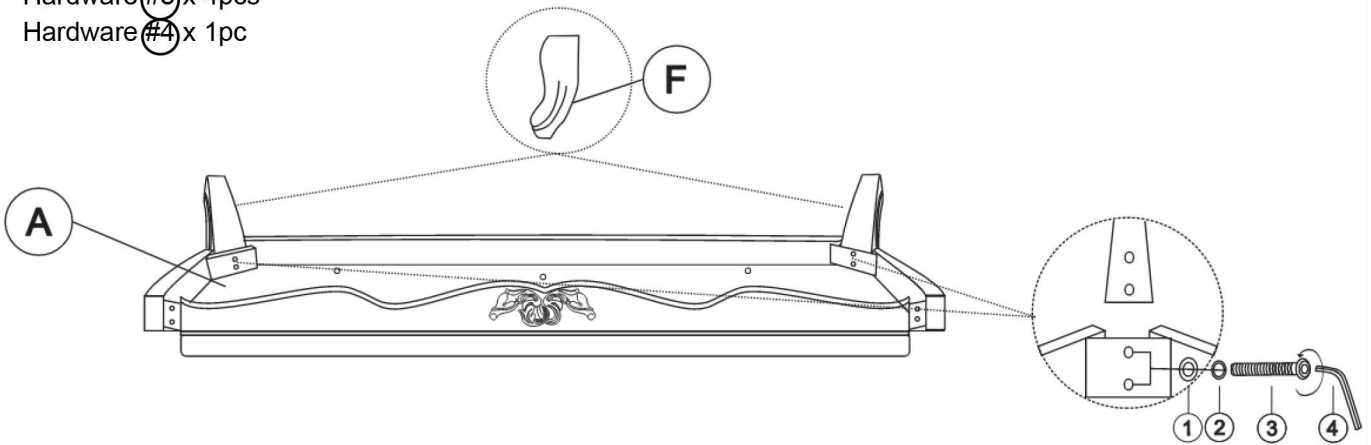

2

Attach the Left/right Facing Arm (#B,#C) Leg to the Seat frame (#A) corner by using Bolt (#5) with Lock washer (#2) and Flat washer (#1). Secure the back side of the arm to the seat by using Bolt (#5) with Lock washer (#2) and Flat washer (#1).

- Part #B x 1pc
- Part #C x 1pc
- Hardware #1 x 6pcs
- Hardware #2 x 6pcs
- Hardware #5 x 6pcs

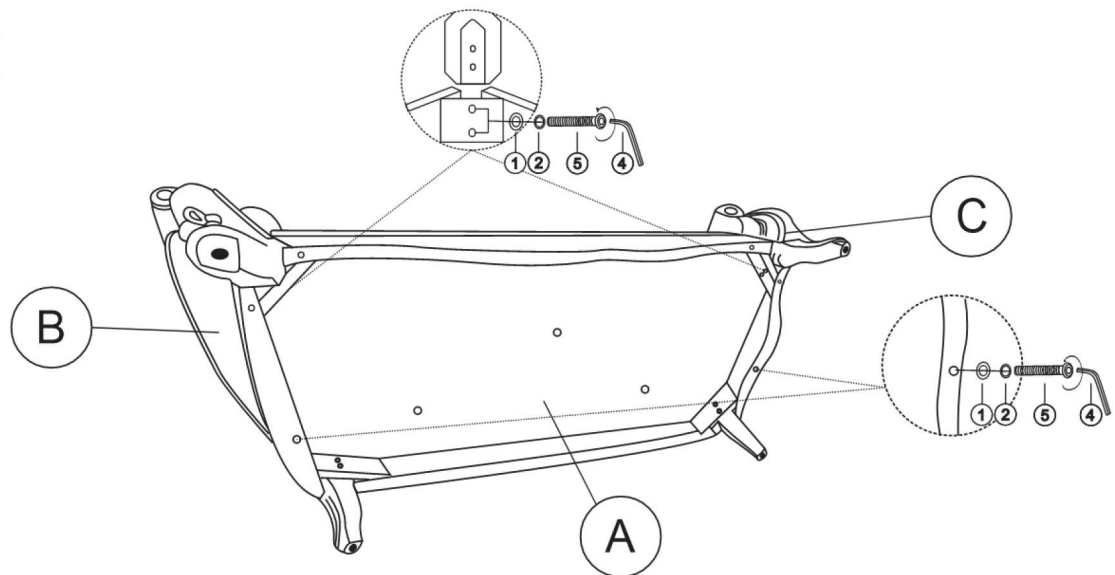

ASSEMBLY INSTRUCTIONS

3

Secure the arms (#B,#C) at the corner by using Screw (#9).

Hardware #9 x 4pcs

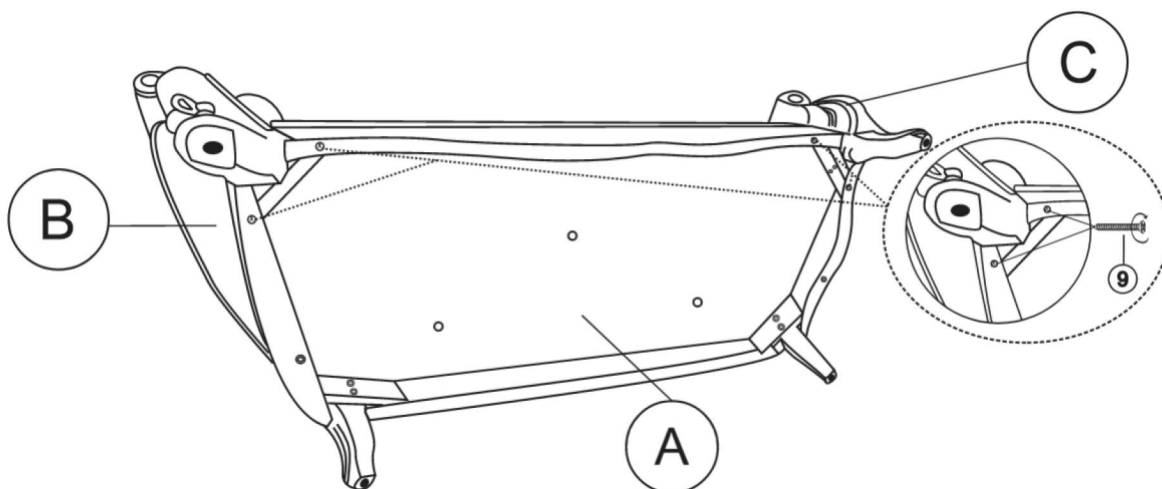

4

Part #D x 1pc
Hardware #6 x 2pcs

Prepare the Backrest (#D) by attaching the Threaded bolt (#6).

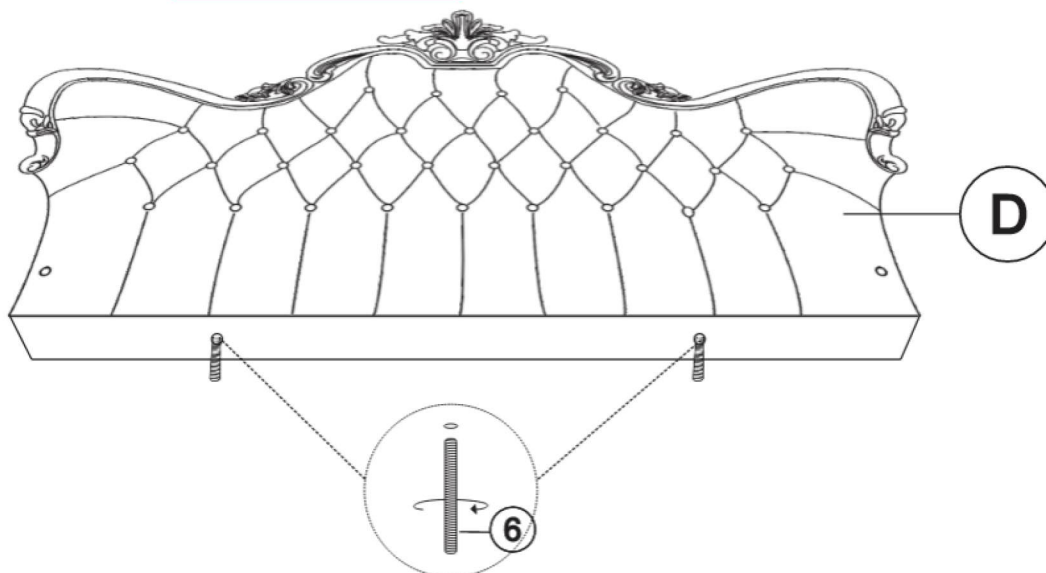

ASSEMBLY INSTRUCTIONS

Align and insert the Backrest (#D) into the Seat frame (#A).

5

Part #D x 1pc

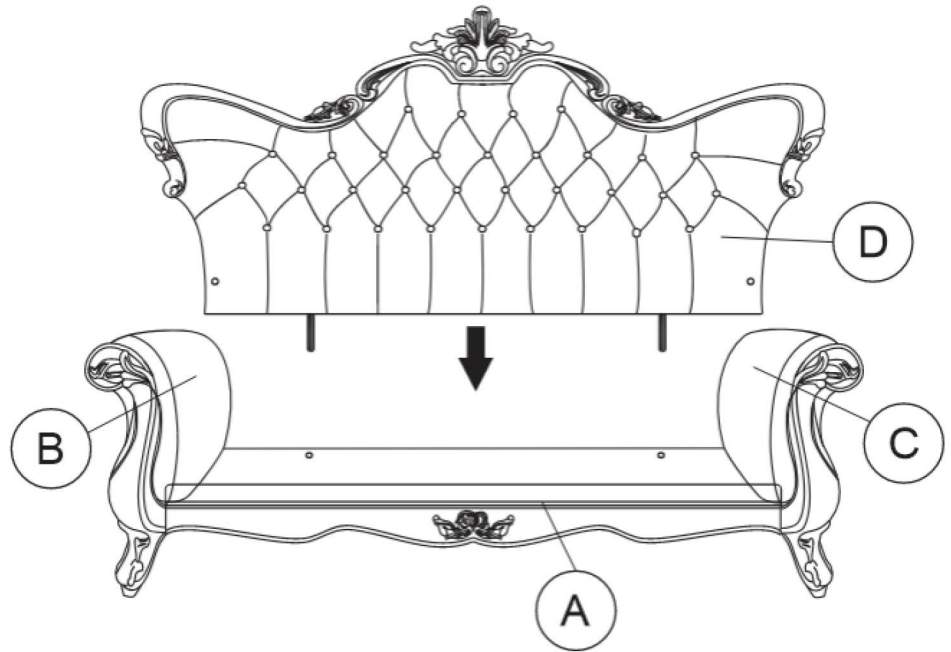

6

Hardware #1 x 2pcs
Hardware #2 x 2pcs
Hardware #3 x 2pcs

Lift Velcro and secure the Backrest (#D) to the arms by using Bolts (#3) with Lock washer (#2) with Flat washer (#1).

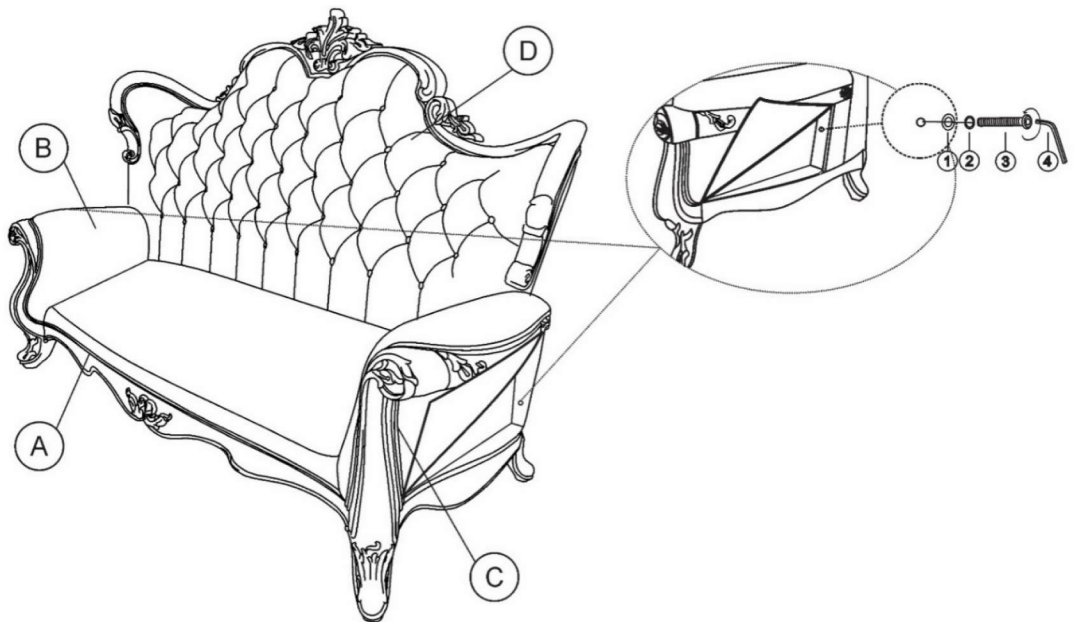

ASSEMBLY INSTRUCTIONS

7

Hardware **#1** x 2pcs

Hardware **#2** x 2pcs

Hardware **#7** x 2pcs

Secure Backrest (#D) under the Seat frame (#A) by using Hex Nut (#7) and Lock washer (#2) with Flat washer (#1).

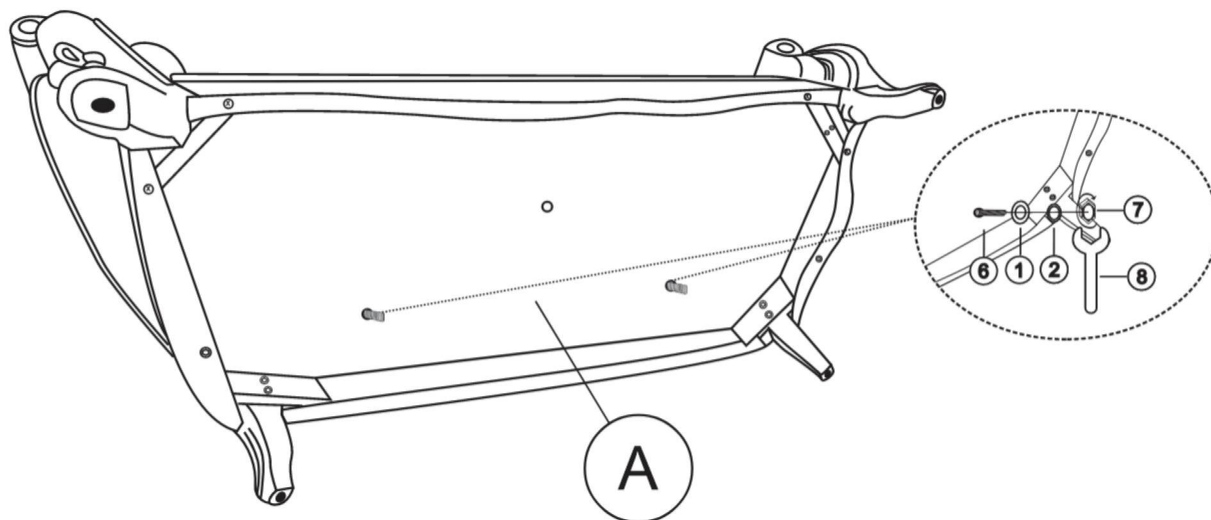

8

Part **#J** x 1pc

Attach the Support Leg at the center under the Seat Frame (#A).

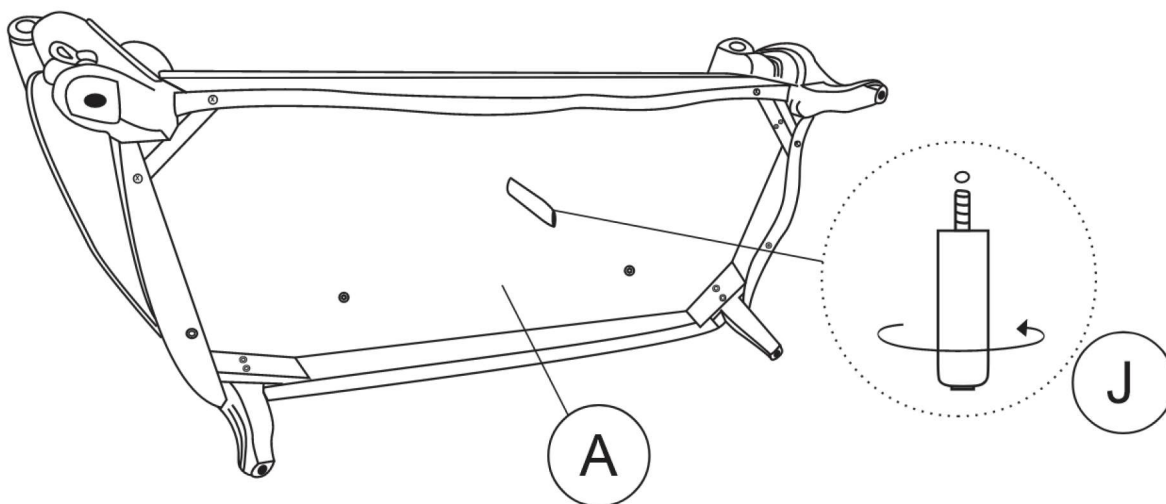

ASSEMBLY INSTRUCTIONS

Place the Seat cushion (#E).

9

Part #E x 1pc

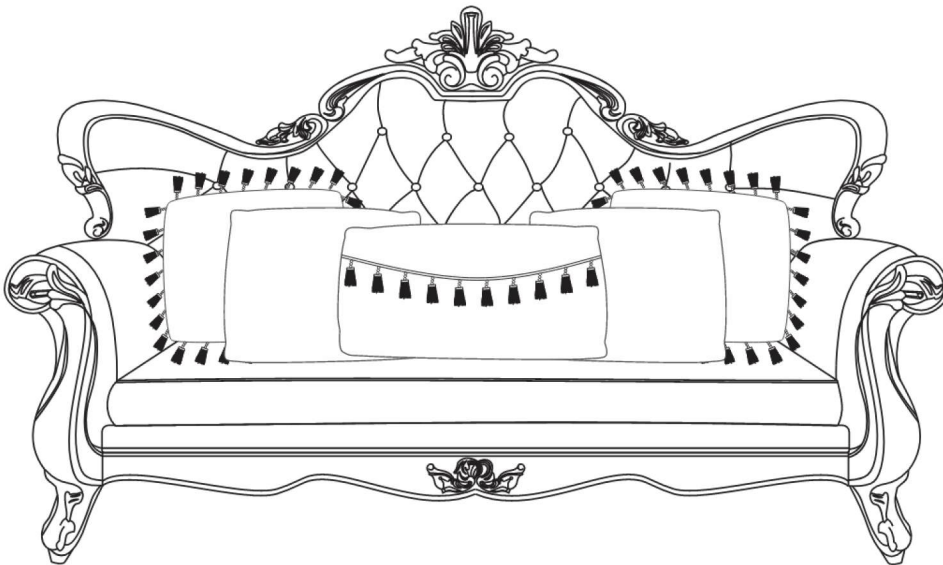
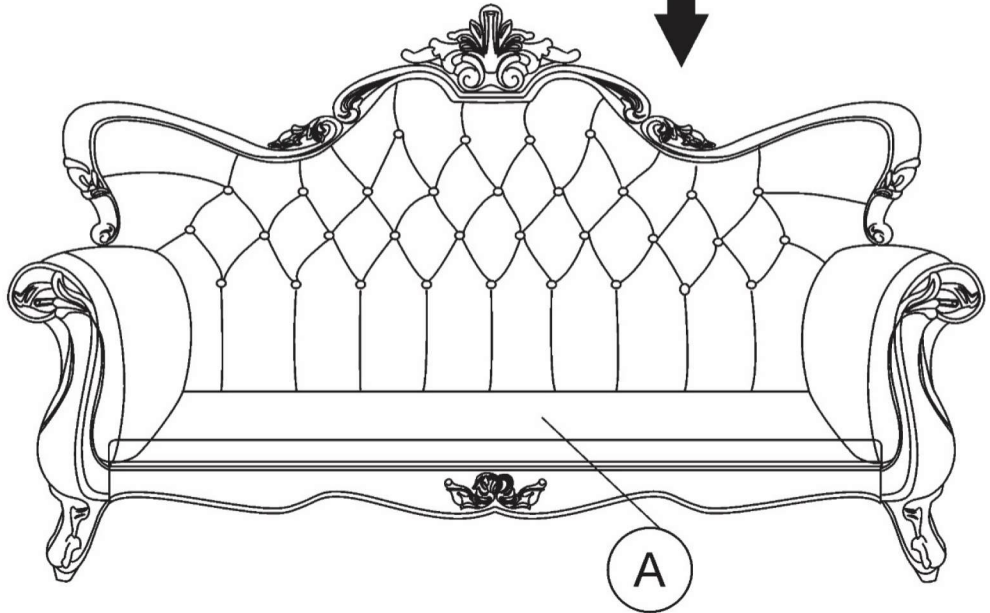

ASSEMBLY COMPLETED



Please ensure the furniture rests on an even and flat surface. If the product wobbles or feels loose, double-check all bolts and/or screws are properly tightened and secured.



Keep this handy!

Please retain this instruction manual and any order-related information for future reference.



Lift, don't drag!

To avoid damage to product please always LIFT the product when transporting or adjusting the placement.