

ASSEMBLY INSTRUCTIONS

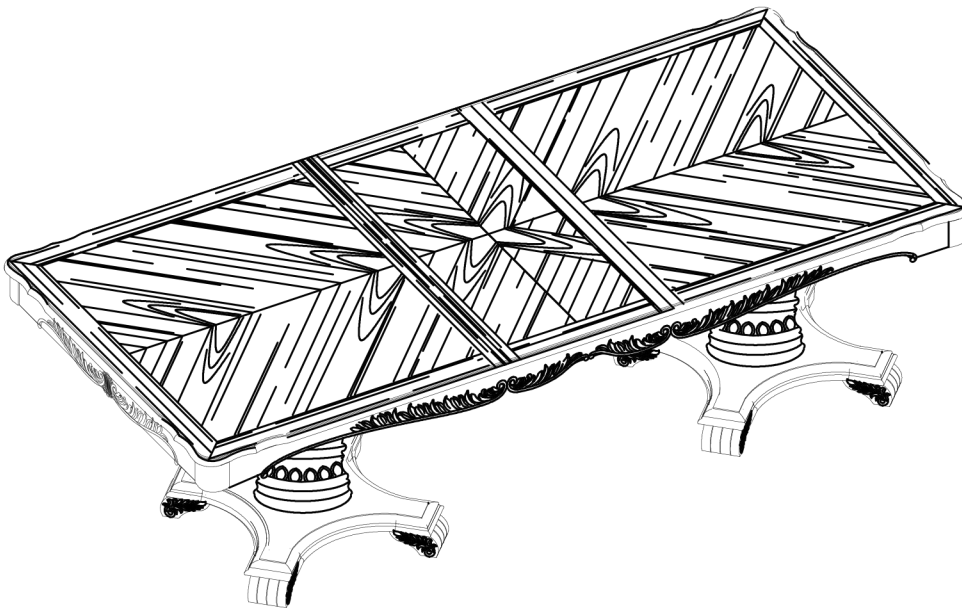

TOOLS REQUIRED



Allen Wrench

(Included)



Phillips Screwdriver

(Not Included)



**2 - People
Recommended**

ASSEMBLY RATING



EASY —————> **DIFFICULT**

The Assembly Rating is a 5-point system showing the level of effort needed to assemble a specific product.



CHECK BEFORE STARTING

Are you missing anything?

Double-check all parts, hardware and accessories listed on Page 6 are accounted for.

Check out our Quick Tips!

We recommend reviewing the pre-assembly handouts. Even experts need a refresher now and then!

Should we send any replacements?

Are there any irregularities or flaws in the parts? We can send replacements!

Prep Time!

Please review the assembly instructions and all diagrams prior to assembling. Set up your workspace by laying the parts and hardware out separately, then begin!

PRE ASSEMBLY INTRODUCTION

We understand building ready-to-assemble furniture can be a challenging experience for some. To help avoid confusion, we have provided some helpful tips that may speed up the process.



Teamwork

ALWAYS have at least two people to help with transporting and assembling the product to avoid potential injury and/or damage.

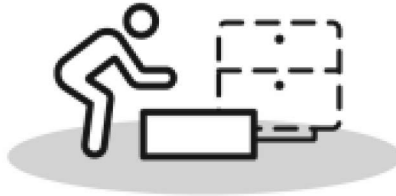

Suitable Location

Assembling near the area of the intended location is highly recommended.



Sufficient Space

Make sure you have enough space to move around during the assembly.



Avoid Scratches

Use cardboard, blankets or a carpeted area while assembling furniture to prevent scratches.

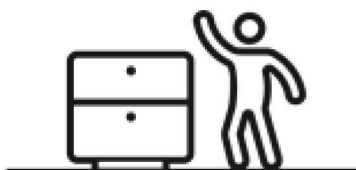

Flat Surface

Make sure the furniture rests on a flat and level surface with each leg evenly touching the floor.

ASSEMBLY AND CARE ADVICE



FAILURE TO FOLLOW THE GUIDELINES BELOW MAY RESULT IN INJURY AND/OR PROPERTY DAMAGE.



Position each part correctly and insert screws or bolts into their respective holes.

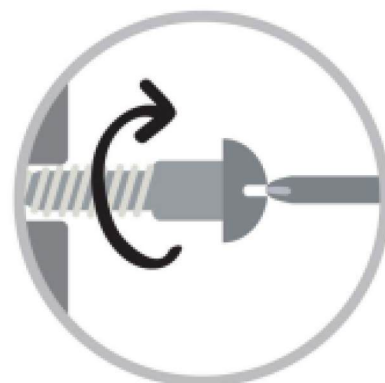

Turn clockwise to tighten and only tighten when step is completed or when instructed to do so.



Use the appropriate hand tools or power tools for assembly. Select steps, such as tightening screws and/or bolts, may require hand tools to avoid causing damage during assembly.



Save the instructions and store any supplied tools for later maintenance.

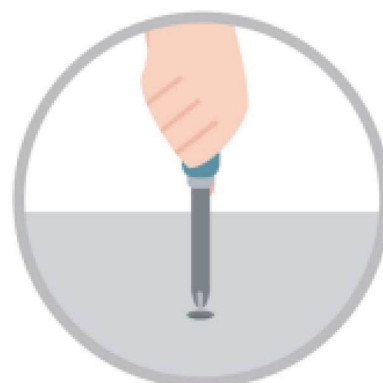

After two weeks, check and tighten any loose hardware and repeat again every six months thereafter.

IT IS THE USER'S RESPONSIBILITY TO MAINTAIN THE FURNITURE. THE HARDWARE MAY LOOSEN OVER TIME AND MAY CAUSE THE FURNITURE TO BE WOBBLY AND UNABLE TO SUPPORT ITS INTENDED WEIGHT CAPACITY. THIS MAY LEAD TO COLLAPSE AND MAY CAUSE SERIOUS INJURY.

TABLE



- Please keep instructions for future reference.
- Check the quantity and irregularity of parts and hardware before you start.

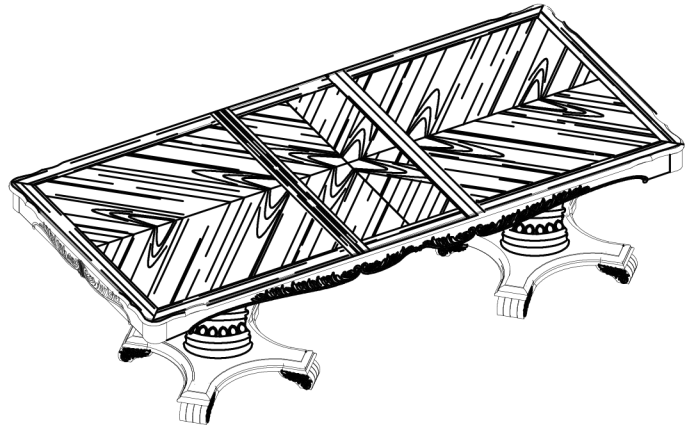

PARTS

#1 1pc

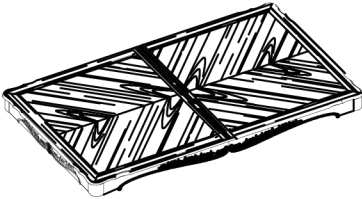

Table Top

#2 1pc



Leaf

#3 2pcs

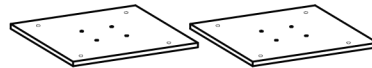

Plate

#4 2pc



pedestal

#5 2pcs

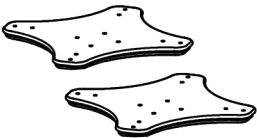

Base

#6 8pcs

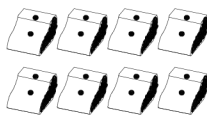

Feet

HARDWARE

#A 32pcs



Bolt
Ø5/16" x 1-5/8"

#B 8pcs



Bolt
Ø5/16" x 2-1/2"

#C 40pcs



Lock Washer
Ø5/16"

#D 40pcs



Flat Washer
Ø5/16" x 22mm

#E 1pc







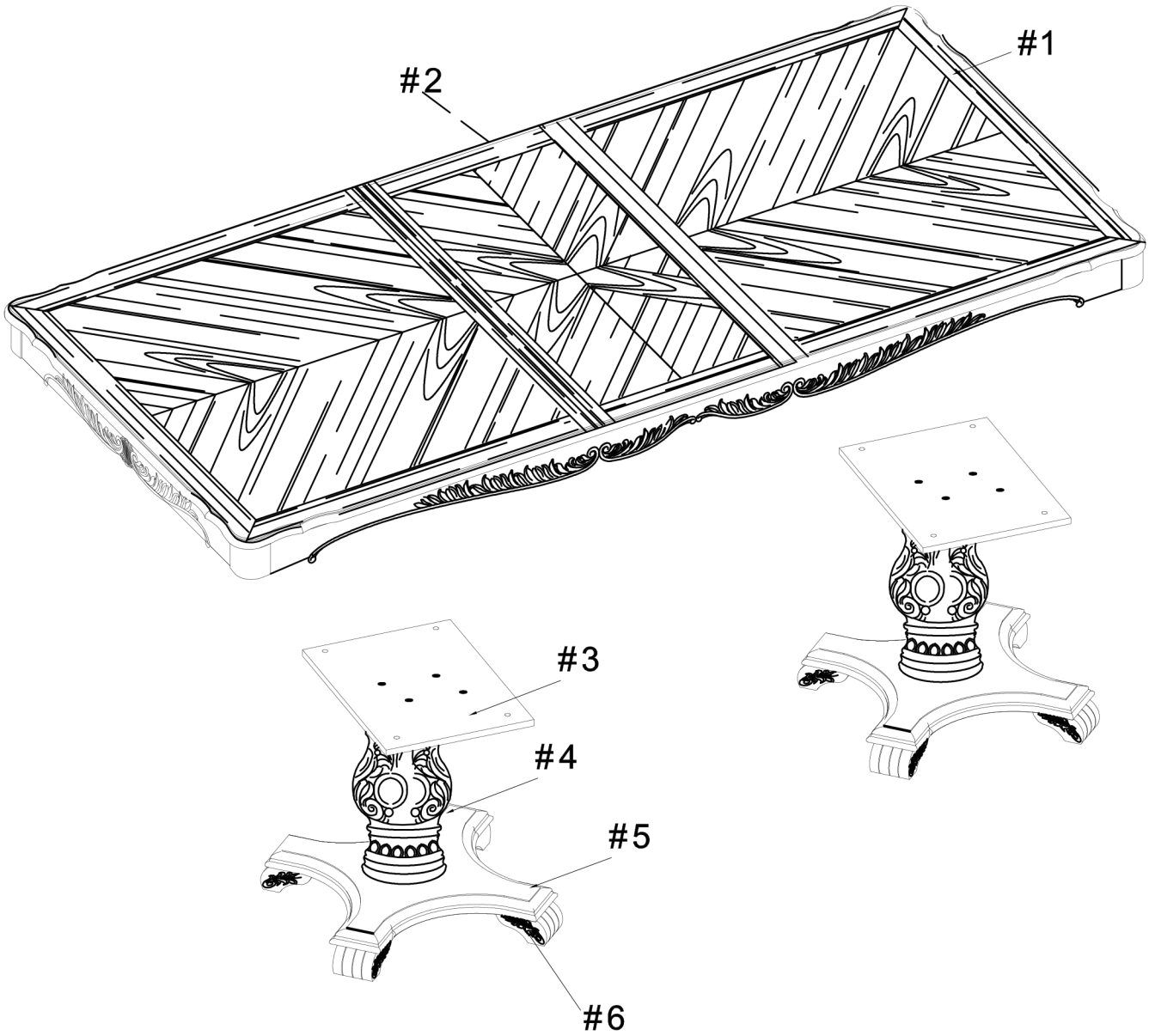



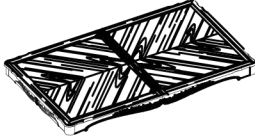

Allen
Wrench M4

Exploded View



packed in 2 cases

Carton	Disignation	Part	Hardware
	Table Top	#1	
	Leaf-1pc	#2	
	Plate2-pcs	#3	
	Base-2pcs	#4	
	plate-2pcs	#5	
	Feet-8pcs	#6	
			 #A x 32pcs  #B x 8pcs  #C x 40pcs  #D x 40pcs  #E x 1pc

ASSEMBLY INSTRUCTIONS

1

- Part #4 x1pc
- Part #5 x1pc
- Hardware #B x4pcs
- Hardware #C x4pcs
- Hardware #D x4pcs

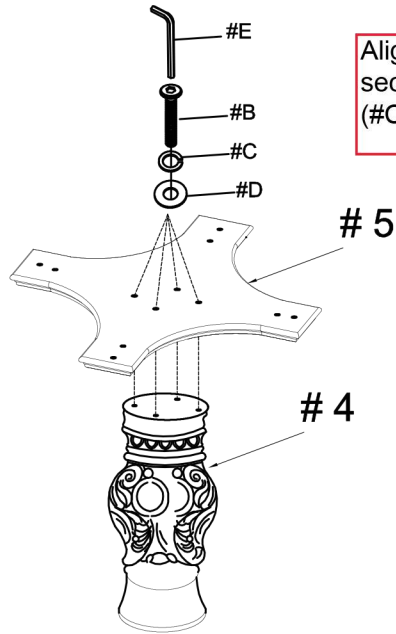

Align the Base (#5) to the Pedestal (#4) and secure by using Bolt (#B) with Lock washer (#C) and Flat washer (#D).

x 2

2

- Part #5 x1pc
- Part #6 x4pcs
- Hardware #A x8pcs
- Hardware #C x8pcs
- Hardware #D x8pcs

Attach the Feet (#6) to the Base (#5) by using Bolt (#A) with lock washer (#C) and Flat washer (#D).

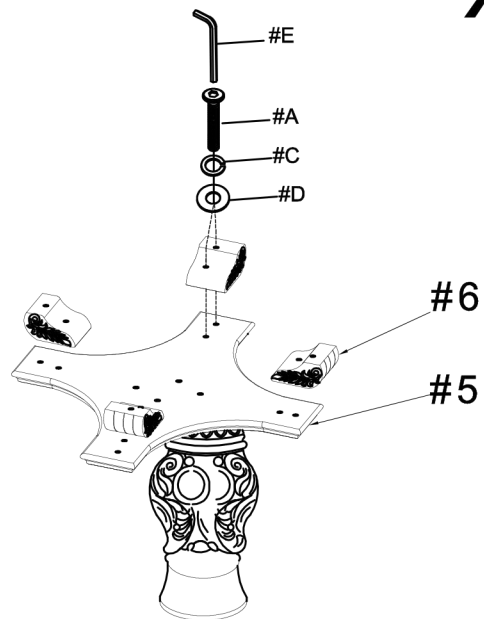

x 2

3

- Part #3 x1pc
- Part #4 x1pc
- Hardware #A x4pcs
- Hardware #C x4pcs
- Hardware #D x4pcs

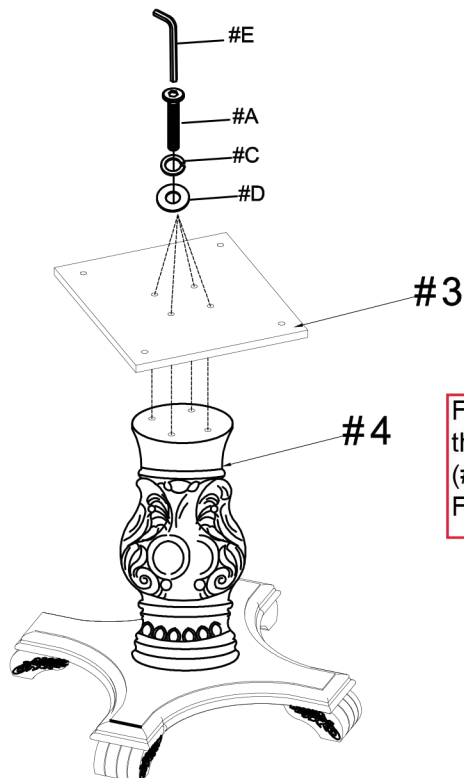

Flip pedestal (#4) over and attach the Plate (#3) to the top with Bolt (#A) with Lock washer (#C) and Flat washer (#D).

x 2

ASSEMBLY INSTRUCTIONS

4

- Part #1 x1pc
- Hardware #A x4pcs
- Hardware #C x4pcs
- Hardware #D x4pcs

Align the Plate(#3) to the Tabletop(#1) and secure together by using Bolt (#A) with Lock washer (#C) and Flat washer (#D).

x 2

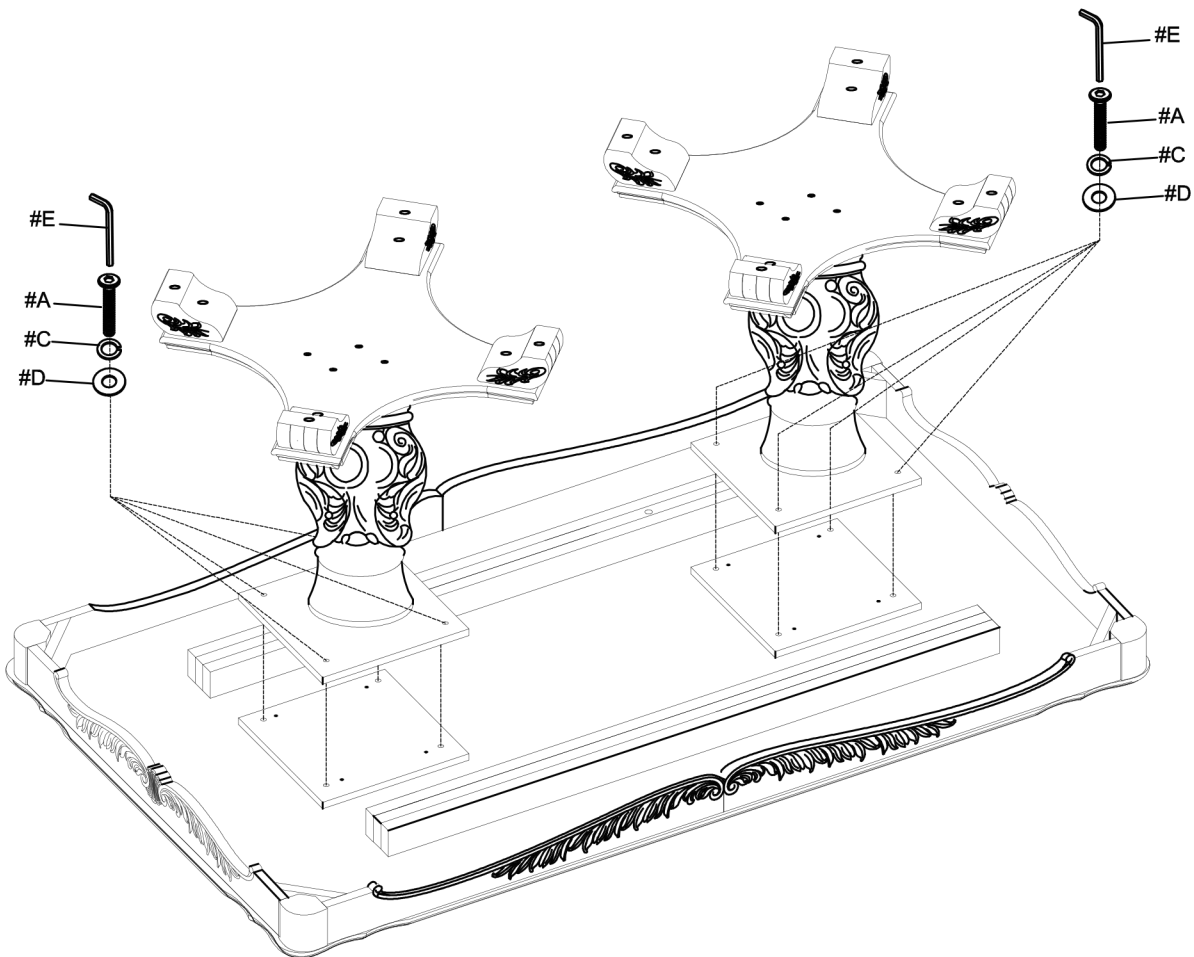

ASSEMBLY INSTRUCTIONS

Unlock locks underneath the tabletop to spread ends out and insert the leaf (#2).

4

Part #2 x1pc

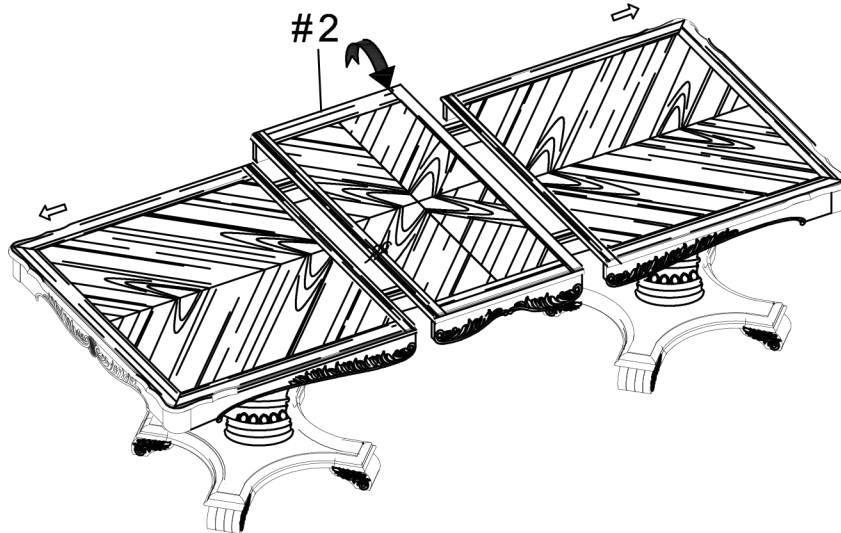
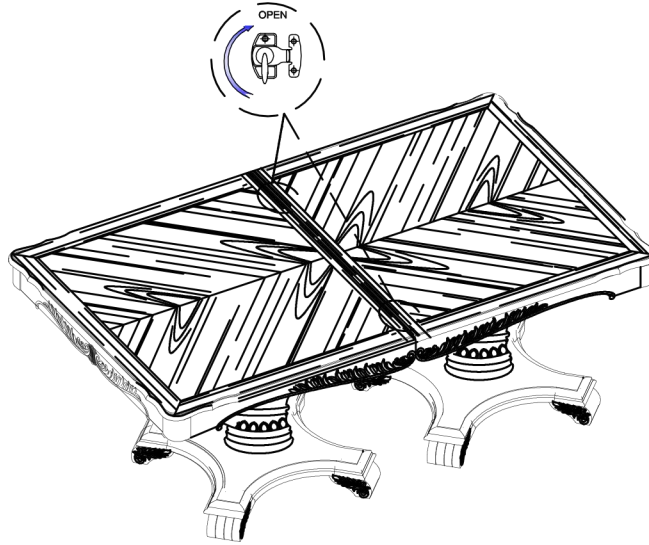

5

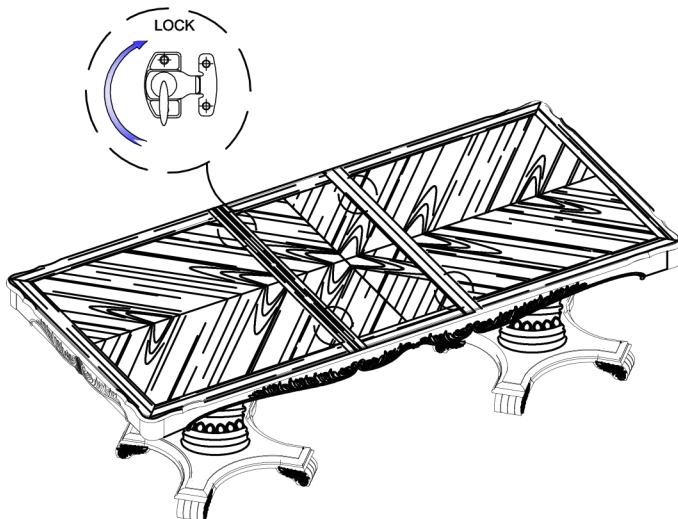

ASSEMBLY COMPLETED



Please ensure the furniture rests on an even and flat surface. If the product wobbles or feels loose, double-check all bolts and/or screws are properly tightened and secured.

Keep this handy!

Please retain this instruction manual and any order-related information for future reference.

Lift, don't drag!

To avoid damage to product please always LIFT the product when transporting or adjusting the placement.

This product is intended for RESIDENTIAL USE ONLY and not for commercial use.

ASSEMBLY INSTRUCTIONS

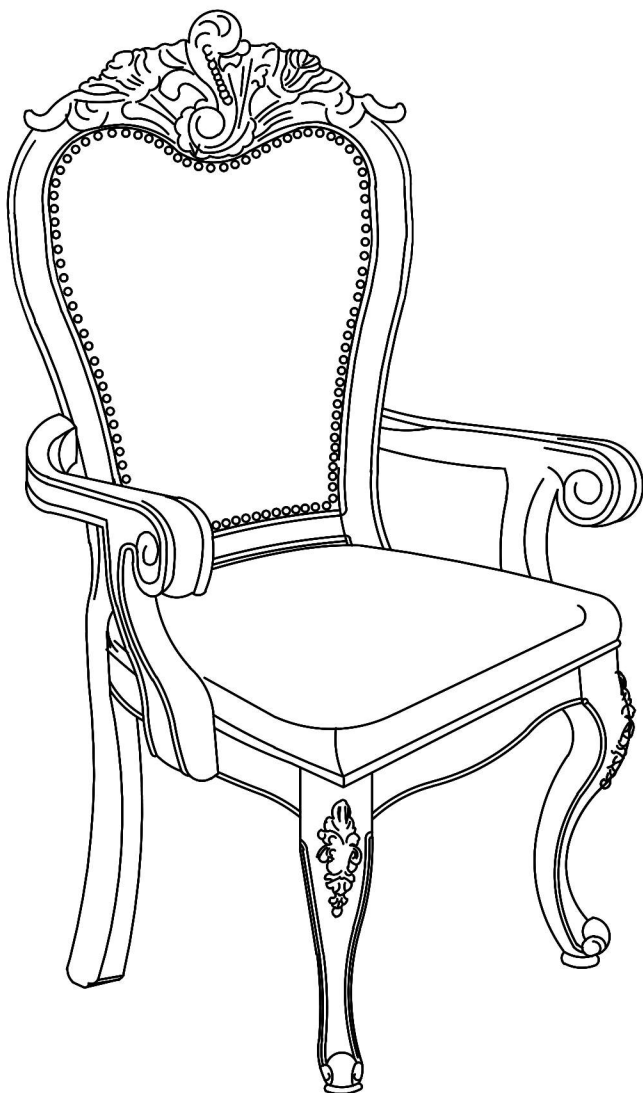

TOOLS REQUIRED



Allen Wrench

(Included)



Phillips
Screwdriver

(Not Included)



2 - People
Recommended

ASSEMBLY RATING



EASY —————> DIFFICULT

The Assembly Rating is a 5-point system showing the level of effort needed to assemble a specific product.



CHECK BEFORE STARTING



Are you missing anything?

Double-check all parts, hardware and accessories listed on Page 6 are accounted for.



Check out our Quick Tips!

We recommend reviewing the pre-assembly handouts. Even experts need a refresher now and then!



Should we send any replacements?

Are there any irregularities or flaws in the parts? We can send replacements!



Prep Time!

Please review the assembly instructions and all diagrams prior to assembling. Set up your workspace by laying the parts and hardware out separately, then begin!

PRE ASSEMBLY INTRODUCTION

We understand building ready-to-assemble furniture can be a challenging experience for some. To help avoid confusion, we have provided some helpful tips that may speed up the process.



Teamwork

ALWAYS have at least two people to help with transporting and assembling the product to avoid potential injury and/or damage.



Suitable Location

Assembling near the area of the intended location is highly recommended.



Sufficient Space

Make sure you have enough space to move around during the assembly.



Avoid Scratches

Use cardboard, blankets or a carpeted area while assembling furniture to prevent scratches.



Flat Surface

Make sure the furniture rests on a flat and level surface with each leg evenly touching the floor.

ASSEMBLY AND CARE ADVICE



FAILURE TO FOLLOW THE GUIDELINES BELOW MAY RESULT IN INJURY AND/OR PROPERTY DAMAGE.



Position each part correctly and insert screws or bolts into their respective holes.

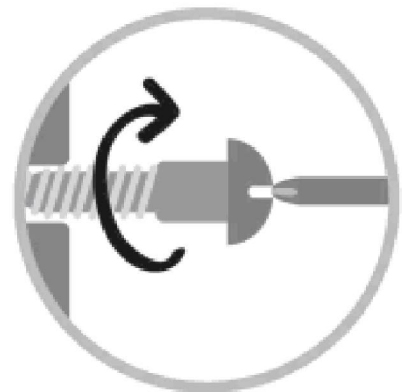

Turn clockwise to tighten and only tighten when step is completed or when instructed to do so.



Use the appropriate hand tools or power tools for assembly. Select steps, such as tightening screws and/or bolts, may require hand tools to avoid causing damage during assembly.



Save the instructions and store any supplied tools for later maintenance.

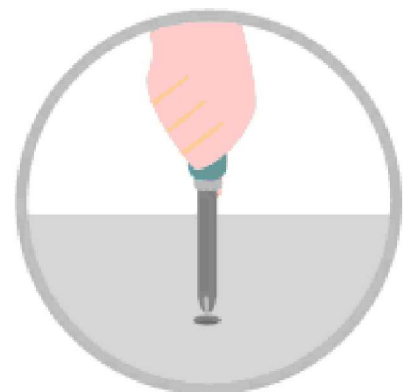

After two weeks, check and tighten any loose hardware and repeat again every six months thereafter.

IT IS THE USER'S RESPONSIBILITY TO MAINTAIN THE FURNITURE. THE HARDWARE MAY LOOSEN OVER TIME AND MAY CAUSE THE FURNITURE TO BE WOBBLY AND UNABLE TO SUPPORT ITS INTENDED WEIGHT CAPACITY. THIS MAY LEAD TO COLLAPSE AND MAY CAUSE SERIOUS INJURY.

ARM CHAIR

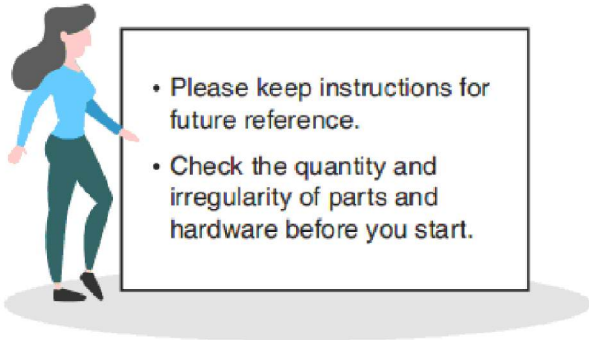
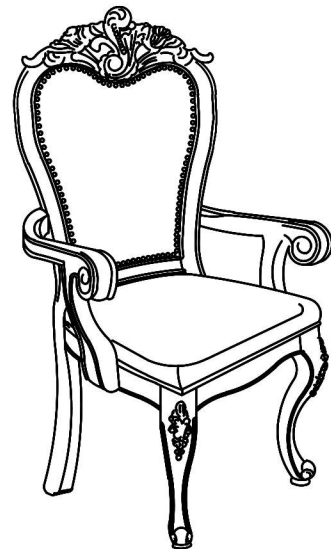

PARTS

#1 1pc x2

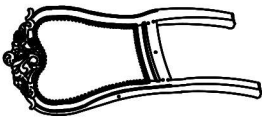

Chair Back

#2 1pc x2



Chair Seat

#3 2pcs x2



Legs

#4 2pcs x2

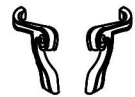

Arm (L&R)

HARDWARE

#A 4pcs x2



Bolt
Ø5/16" x 3-1/4"

#B 7pcs x2



Bolt
Ø5/16" x 1-3/4"

#C 11pcs x2



Lock Washer
Ø5/16"

#D 11pcs x2



Flat Washer
Ø5/16"x22mm

#E 1pc x2



Allen Wrench M4

#F 2pcs x2



Screw
#8 x 50mm

Exploded View

x 2

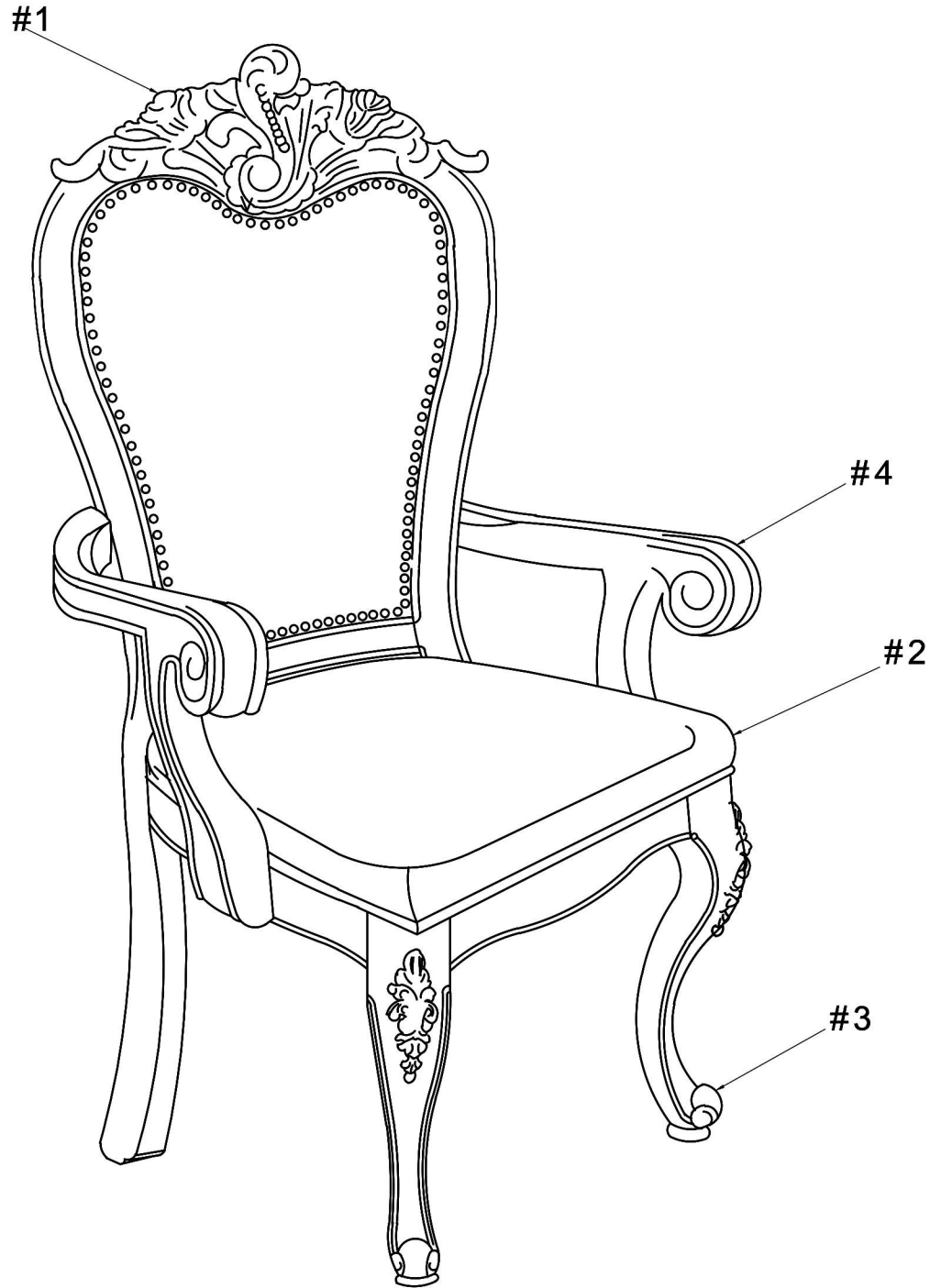

ASSEMBLY INSTRUCTIONS

Align the Leg (#3) to the Chair seat (#2) and secure by using Bolt (#B) with Lock washer (#C) and Flat washer (#D).

1

- Part #2 x1pc
- Part #3 x2pc
- Hardware #B x4pcs
- Hardware #C x4pcs
- Hardware #D x4pcs

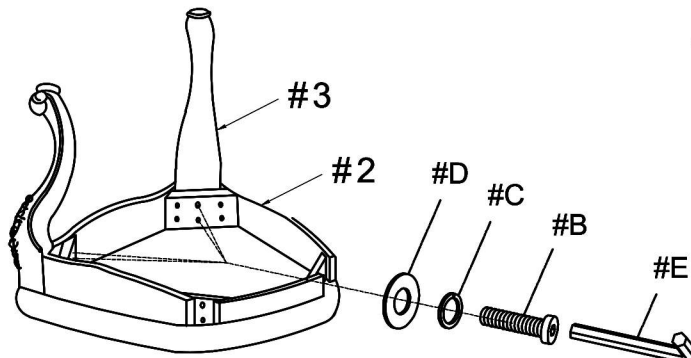

x 2

2

Align the Chair seat (#2) to the Chair back (#1) and secure at the center by using Bolt (#B) and Lock washer (#C) and Flat washer (#D).

- Part #1 x1pc
- Hardware #B x1pc
- Hardware #C x1pc
- Hardware #D x1pc

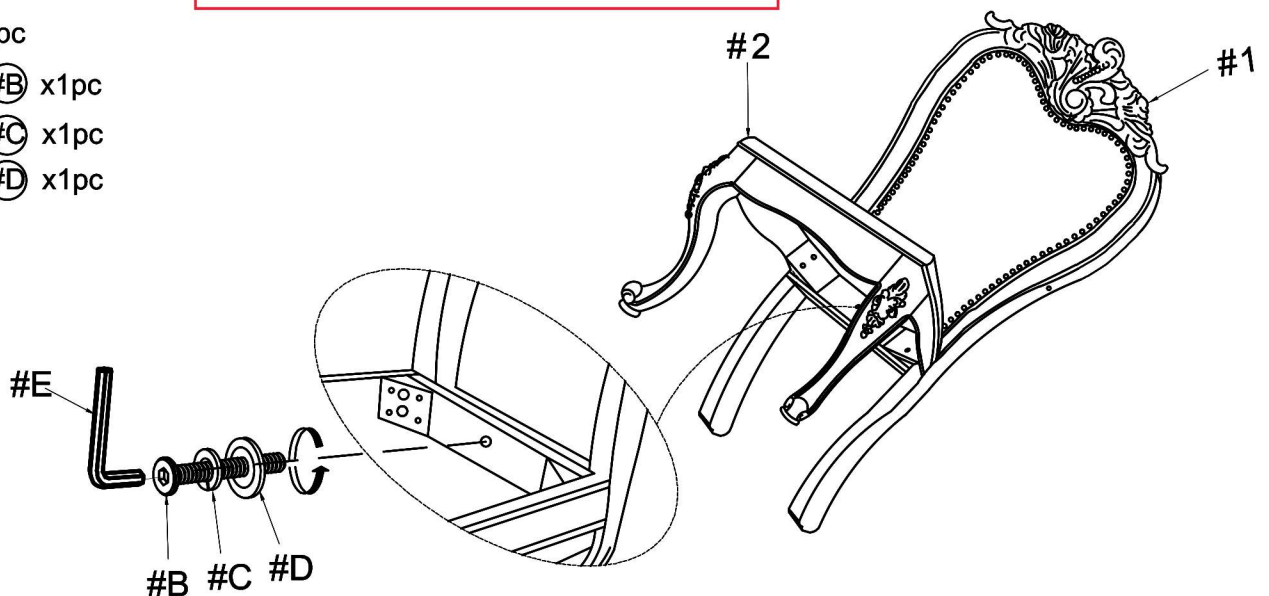

x 2

ASSEMBLY INSTRUCTIONS

Secure the back legs to the corner of the Chair seat (#2) by using Bolt (#A) with Lock washer (#C) and Flat washer (#D).

3

- Hardware (#A) x4pcs
- Hardware (#C) x4pcs
- Hardware (#D) x4pcs

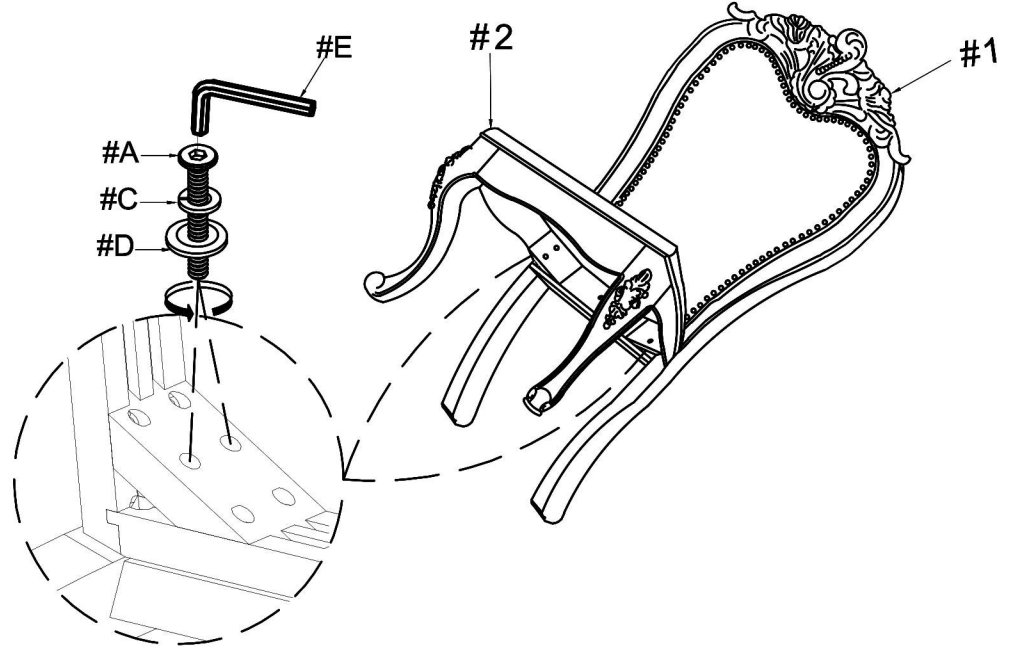

4

- Part (#4) x2pcs
- Hardware (#B) x2pcs
- Hardware (#C) x2pcs
- Hardware (#D) x2pcs

Align the Arm (#4) to the Chair seat (#2) and secure with Bolt (#B) with Lock washer (#C) and Flat washer (#D).

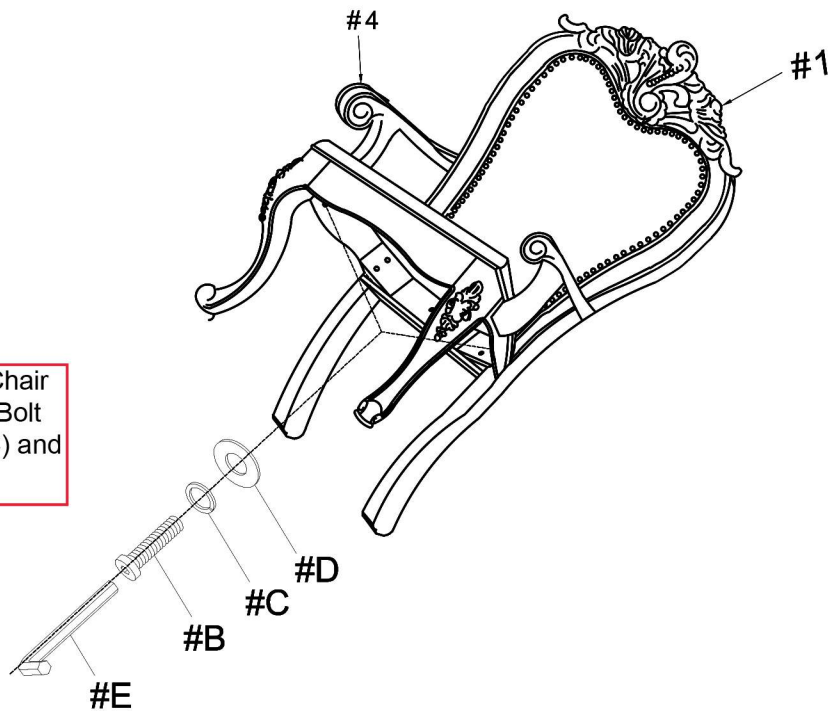

ASSEMBLY INSTRUCTIONS

5

Hardware (#F) x2pcs

Secure the top of the Arm rest (#4) to the Chair back (#1) by using Screw (#F).

x 2

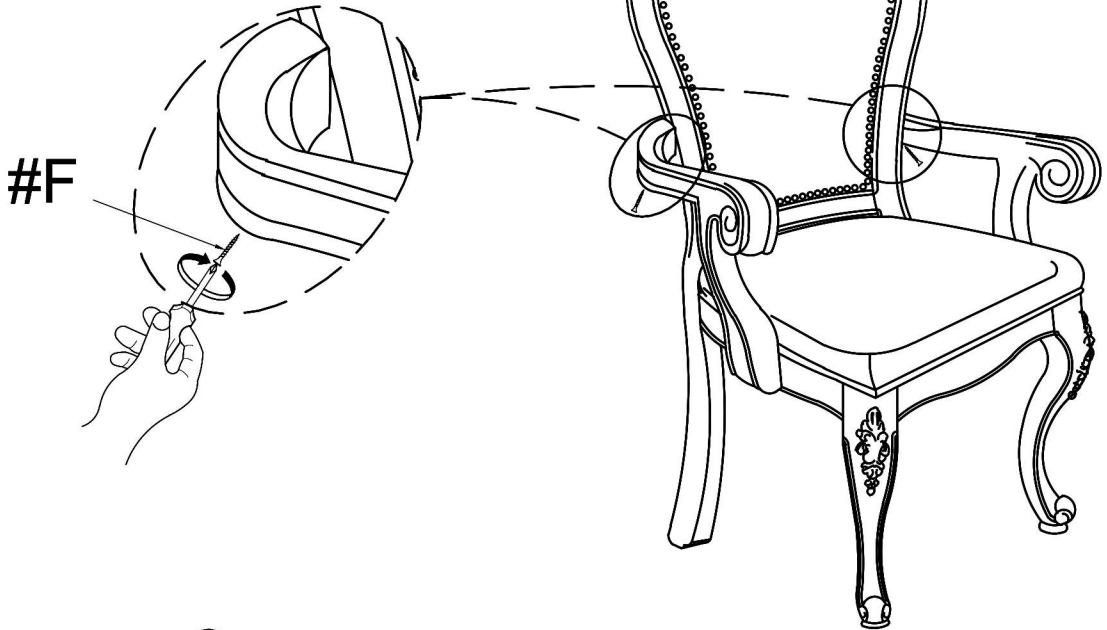

6

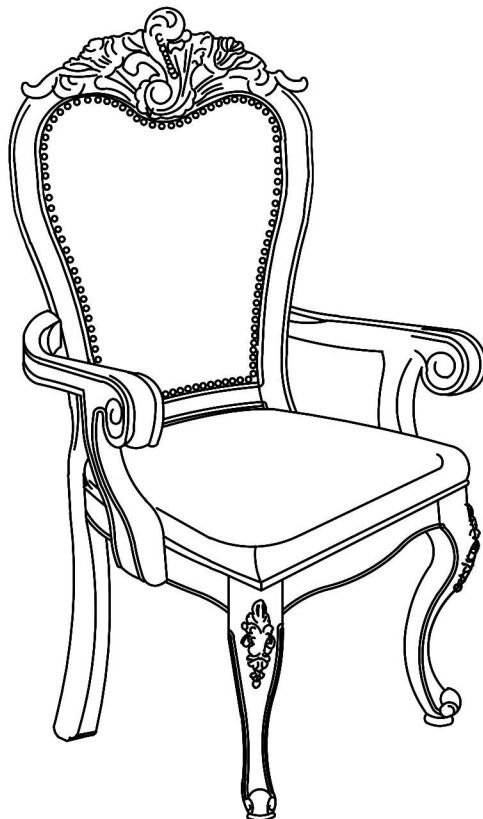

ASSEMBLY COMPLETED



Please ensure the furniture rests on an even and flat surface. If the product wobbles or feels loose, double-check all bolts and/or screws are properly tightened and secured.



Keep this handy!

Please retain this instruction manual and any order-related information for future reference.



Lift, don't drag!

To avoid damage to product please always LIFT the product when transporting or adjusting the placement.

This product is intended for RESIDENTIAL USE ONLY and not for commercial use.

ASSEMBLY INSTRUCTIONS

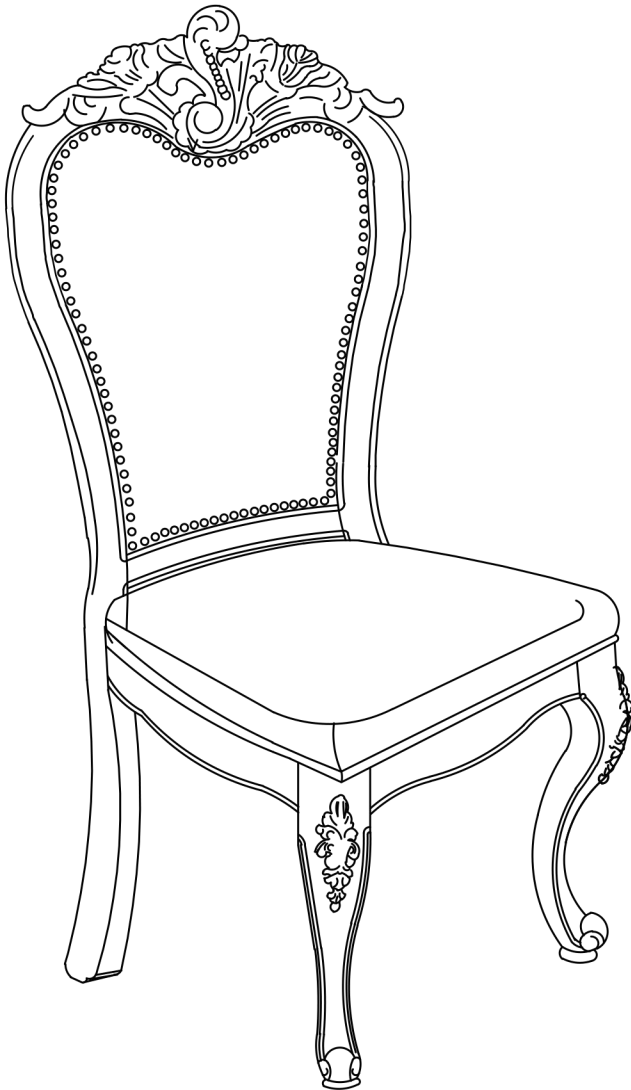

TOOLS REQUIRED



Allen Wrench

(Included)



Phillips
Screwdriver

(Not Included)

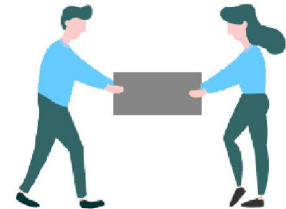

2 - People
Recommended

ASSEMBLY RATING



EASY —————> DIFFICULT

The Assembly Rating is a 5-point system showing the level of effort needed to assemble a specific product.



CHECK BEFORE STARTING



Are you missing anything?

Double-check all parts, hardware and accessories listed on Page 6 are accounted for.



Check out our Quick Tips!

We recommend reviewing the pre-assembly handouts. Even experts need a refresher now and then!



Should we send any replacements?

Are there any irregularities or flaws in the parts? We can send replacements!



Prep Time!

Please review the assembly instructions and all diagrams prior to assembling. Set up your workspace by laying the parts and hardware out separately, then begin!

PRE ASSEMBLY INTRODUCTION

We understand building ready-to-assemble furniture can be a challenging experience for some. To help avoid confusion, we have provided some helpful tips that may speed up the process.



Teamwork

ALWAYS have at least two people to help with transporting and assembling the product to avoid potential injury and/or damage.



Suitable Location

Assembling near the area of the intended location is highly recommended.



Sufficient Space

Make sure you have enough space to move around during the assembly.



Avoid Scratches

Use cardboard, blankets or a carpeted area while assembling furniture to prevent scratches.



Flat Surface

Make sure the furniture rests on a flat and level surface with each leg evenly touching the floor.

ASSEMBLY AND CARE ADVICE



FAILURE TO FOLLOW THE GUIDELINES BELOW MAY RESULT IN INJURY AND/OR PROPERTY DAMAGE.



Position each part correctly and insert screws or bolts into their respective holes.

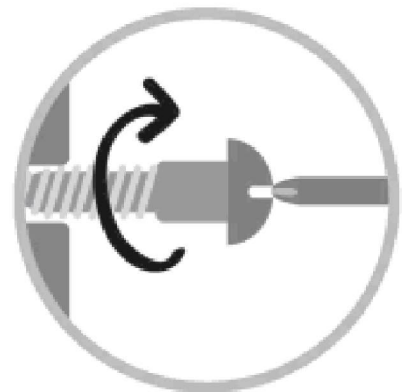

Turn clockwise to tighten and only tighten when step is completed or when instructed to do so.



Use the appropriate hand tools or power tools for assembly. Select steps, such as tightening screws and/or bolts, may require hand tools to avoid causing damage during assembly.



Save the instructions and store any supplied tools for later maintenance.

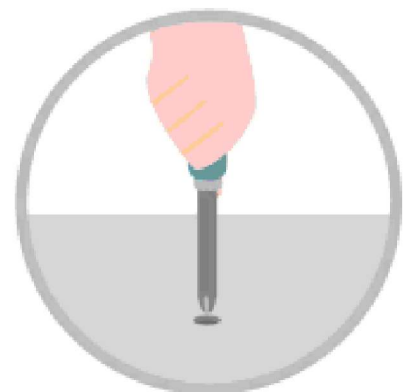

After two weeks, check and tighten any loose hardware and repeat again every six months thereafter.

IT IS THE USER'S RESPONSIBILITY TO MAINTAIN THE FURNITURE. THE HARDWARE MAY LOOSEN OVER TIME AND MAY CAUSE THE FURNITURE TO BE WOBBLY AND UNABLE TO SUPPORT ITS INTENDED WEIGHT CAPACITY. THIS MAY LEAD TO COLLAPSE AND MAY CAUSE SERIOUS INJURY.

SIDE CHAIR

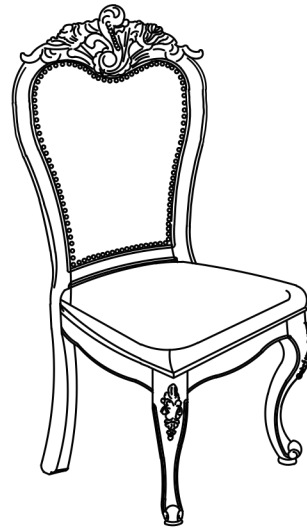
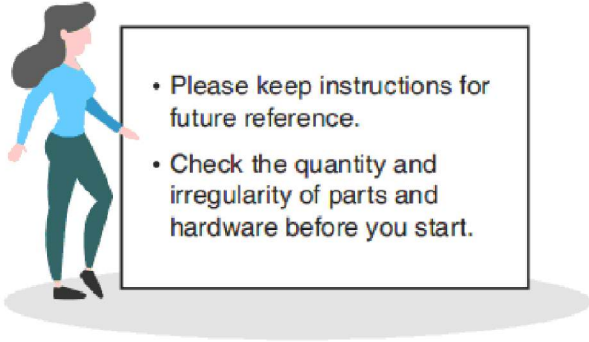

PARTS

#1 1pc x2

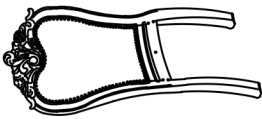

Chair Back

#2 1pc x2



Chair Seat

#3 2pcs x2

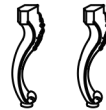

Legs

HARDWARE

#A 4pcs x2



Bolt
Ø5/16" x 3-1/4"

#B 5pcs x2



Bolt
Ø5/16" x 1-3/4"

#C 9pcs x2



Lock Washer
Ø5/16"

#D 9pcs x2



Flat Washer
Ø5/16"x22mm

#E 1pc x2



Allen Wrench M4

Exploded View

x 2

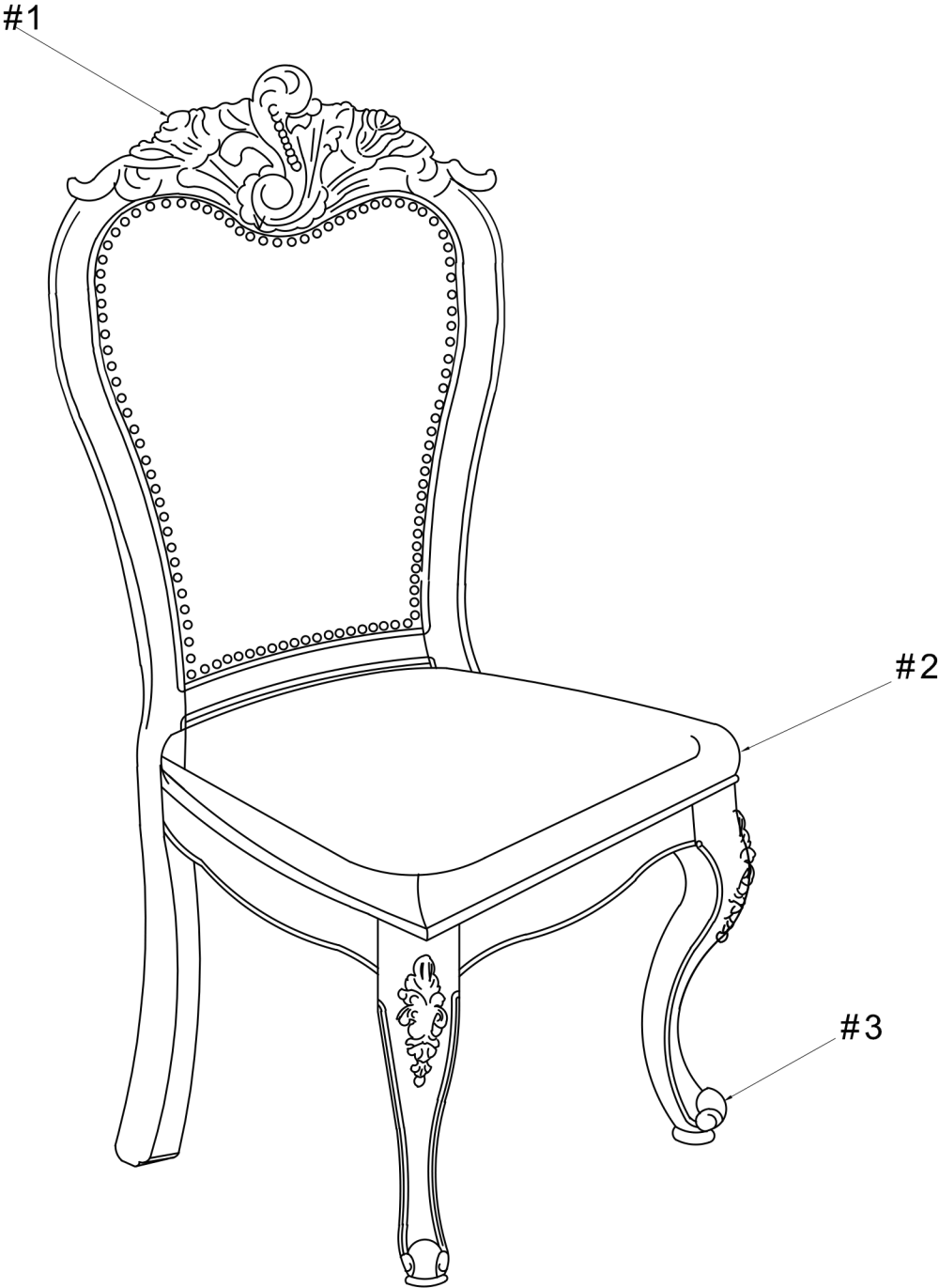

ASSEMBLY INSTRUCTIONS

Align the Leg (#3) to the Chair seat (#2) and secure by using Bolt (#B) with Lock washer (#C) and Flat washer (#D).

x 2

1

- Part #2 x1pc
- Part #3 x2pc
- Hardware #B x4pcs
- Hardware #C x4pcs
- Hardware #D x4pcs

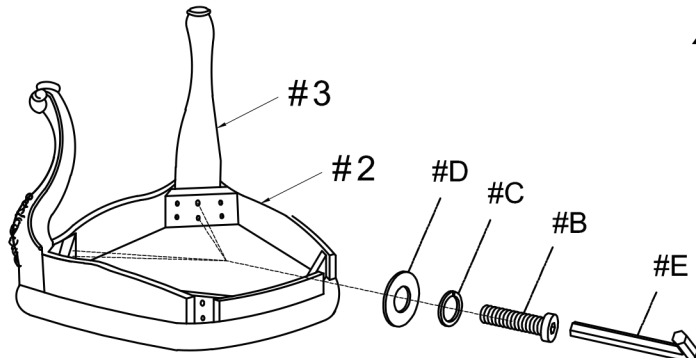

x 2

2

Align the Chair seat (#2) to the Chair back (#1) and secure at the center by using Bolt (#B) and Lock washer (#C) and Flat washer (#D).

- Part #1 x1pc
- Hardware #B x1pc
- Hardware #C x1pc
- Hardware #D x1pc

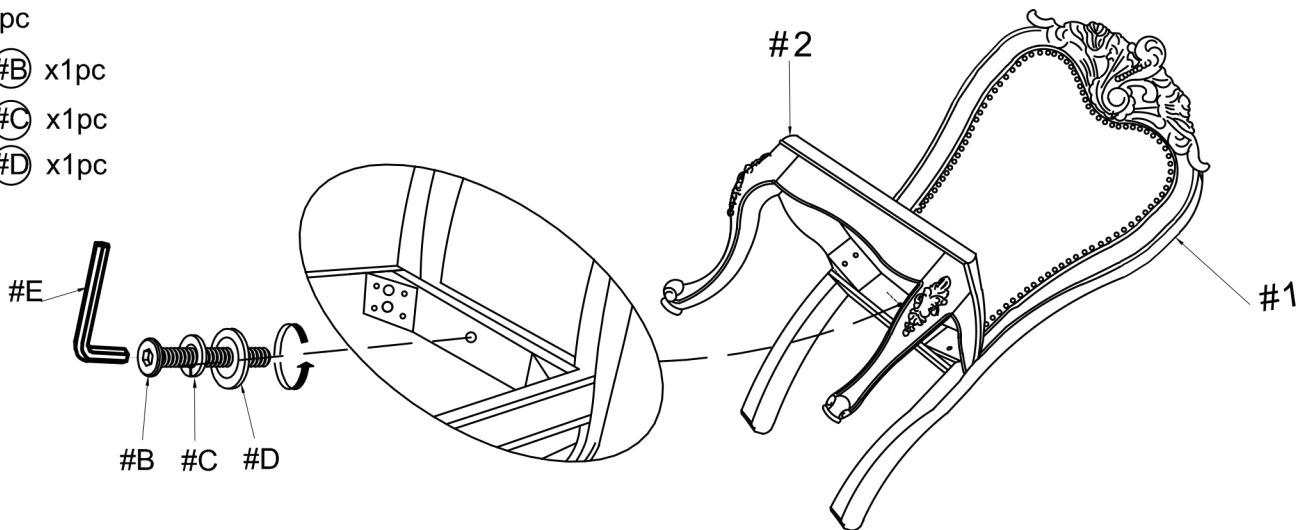

ASSEMBLY INSTRUCTIONS

Secure the back legs to the corner of the Chair seat (#2) by using Bolt (#A) with Lock washer (#C) and Flat washer (#D).

x 2

3

Hardware #A x4pcs

Hardware #C x4pcs

Hardware #D x4pcs

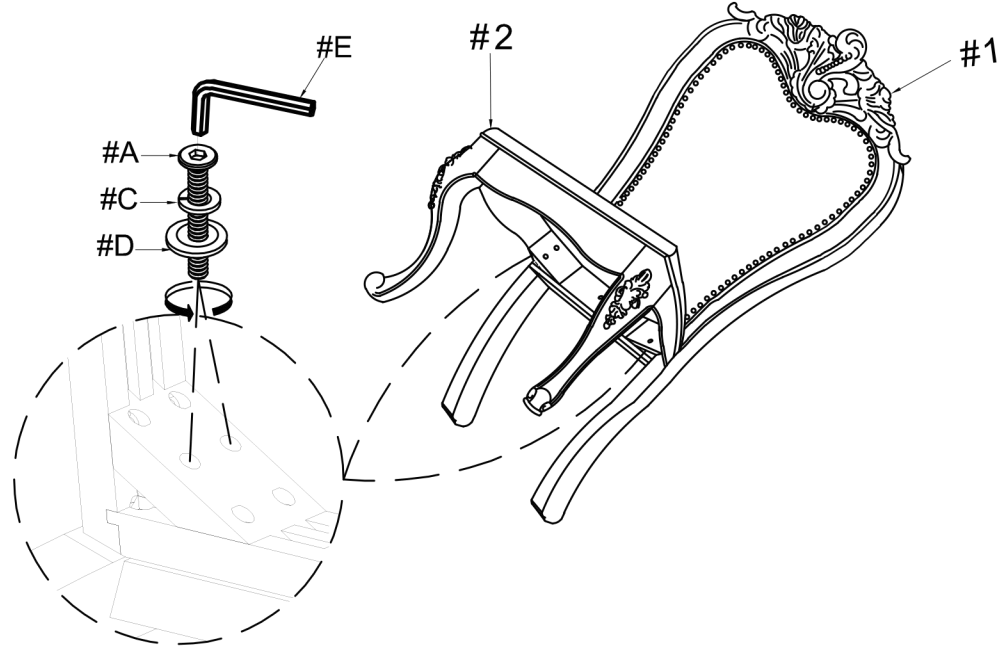

x 2

4

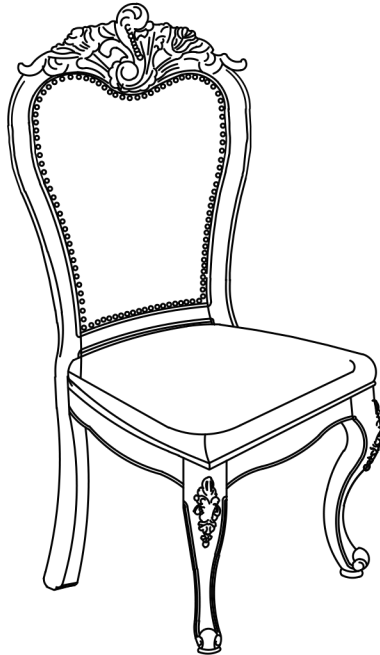

ASSEMBLY COMPLETED



Please ensure the furniture rests on an even and flat surface. If the product wobbles or feels loose, double-check all bolts and/or screws are properly tightened and secured.



Keep this handy!

Please retain this instruction manual and any order-related information for future reference.



Lift, don't drag!

To avoid damage to product please always LIFT the product when transporting or adjusting the placement.

This product is intended for RESIDENTIAL USE ONLY and not for commercial use.