

ASSEMBLY INSTRUCTIONS

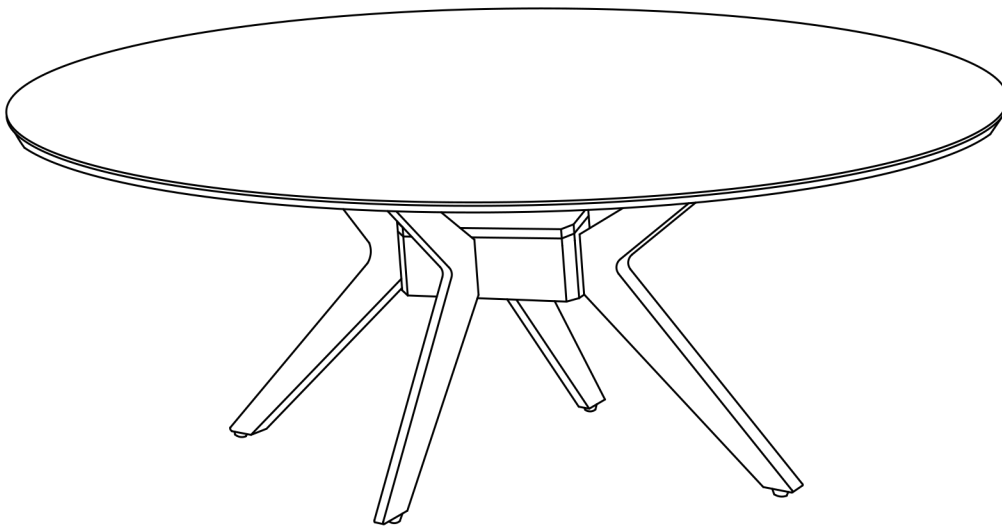

TOOLS REQUIRED



Screwdriver
(Not included)



Allen Wrench
(Included)



2 - People

ASSEMBLY RATING



EASY → DIFFICULT

The Assembly Rating is a 5-point system showing the level of the effort needed to assemble a specific product.



CHECK BEFORE STARTING

- Are you missing anything?**
Double-check all parts, hardware and accessories listed are all accounted for.
- Should we send any replacements?**
Are there any irregularities or flaws in the parts? We can send replacements!

- Check out our Quick Tips!**
We recommend reviewing the pre-assembly handouts. Even experts need a refresher now and then!
- Prep Time!**
Please review the assembly instructions and all diagrams prior to assembling.

PRE ASSEMBLY INSTRUCTION

We understand building ready-to-assemble furniture can be a challenging experience for some. To help avoid confusion, we have provided some helpful tips that may speed up the process.



Teamwork

ALWAYS have at least two people to help with transporting and assembling the product to avoid potential injury and/or damage.

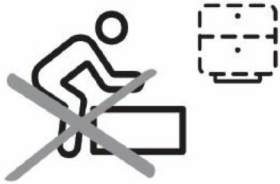

Suitable Location

Assembling near the area of the intended location is highly recommended.



Sufficient Space

Make sure you have enough space to move around during the assembly.



Avoid Scratches

Use cardboard, blankets or a carpeted area while assembling furniture to prevent scratches and damages.



Flat Surface

Make sure the furniture rests on a flat and level surface with each leg evenly touching the floor.

ASSEMBLY AND CARE ADVICE



FAILURE TO FOLLOW THE GUIDELINES BELOW MAY RESULT IN INJURY AND/OR PROPERTY DAMAGE.



Position each part correctly, and insert screws or bolts into their respective holes.

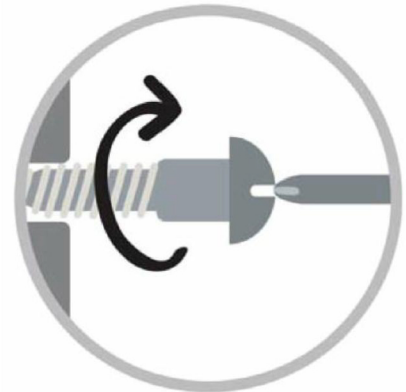

Turn clockwise to tighten and only tighten when step is completed or when instructed to do so.



Use the appropriate handtools or powertools for assembly. Select steps, such as tightnrning screws and/or bolts, may require handtools to avoid causing damage during assembly.



Save the instruction and store any supplied tools for later maintenance.



After two weeks, check and tighten any loose hardware and repeat again every six months thereafter.

IT IS THE USER'S RESPONSIBILITY MAINTAIN THE FURNITURE. THE HARDWARE MAY LOOSEN OVER TIME AND MAY CAUSE THE FURNITURE TO WOOLBY AND UNABLE TO SUPPORT ITS INTENDED WEIGHT CAPACITY. THIS MAY LEAD TO COLLAPSE AND MAY USE SERIOUS INJURY.

DINING TABLE



- Please keep instructions for future reference.
- Check the quantity and irregularity of parts and hardware before you start.

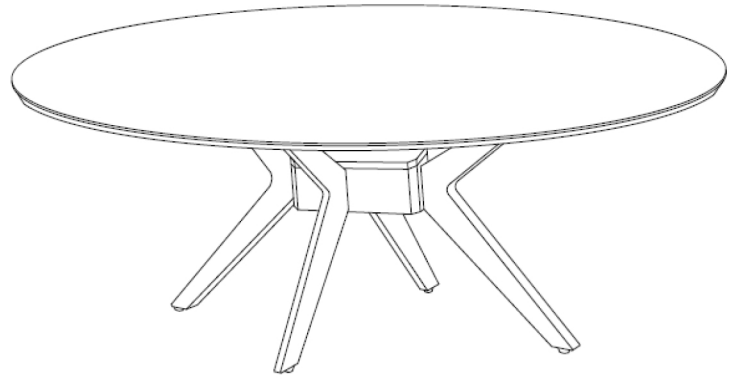

PARTS

1



TABLE TOP
1pc.

2

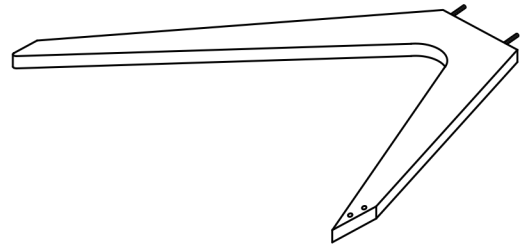
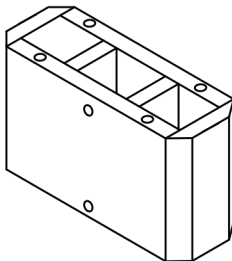

TABLE LEG
4pcs.

3



CENTER BOX
1pc.

4

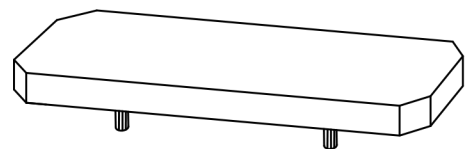

CENTER BOX COVER
1pc.

HARDWARE

A

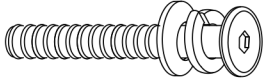

JCBC M6 x 70mm + S/W M6
+ F/W M6 x 13mm
4pcs.

B



ALLEN KEY M4
(BALL SHAPE)
1pc.

C

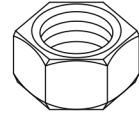

HEX NUT 5/16"
8pcs.

D

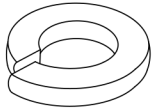

SPRING WASHER 5/16"
8pcs.

E

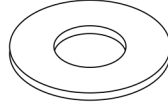

FLAT WASHER 5/16"
8pcs.

F

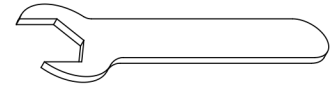





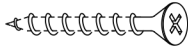

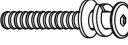

SPANNER 12.8
1pc.

G

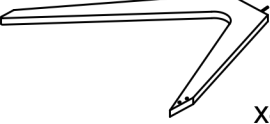
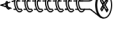
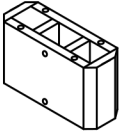

FH SCREW #8 x 32mm
4pcs.

packed in 2 cartons

Carton	Designation	Parts	Hardware
	Table Top & Leg	#1  x1	 #A x4pcs  #B x1pc
		#2  x4	 #G x4pcs
	Centre Box	#3  x1	 #C x8pcs  #D x8pcs
		#4  x1	 #E x8pcs  #F x1pc

ASSEMBLY INSTRUCTIONS

1

ATTENTION:
DO NOT FULLY TIGHTEN THE HEX NUTS

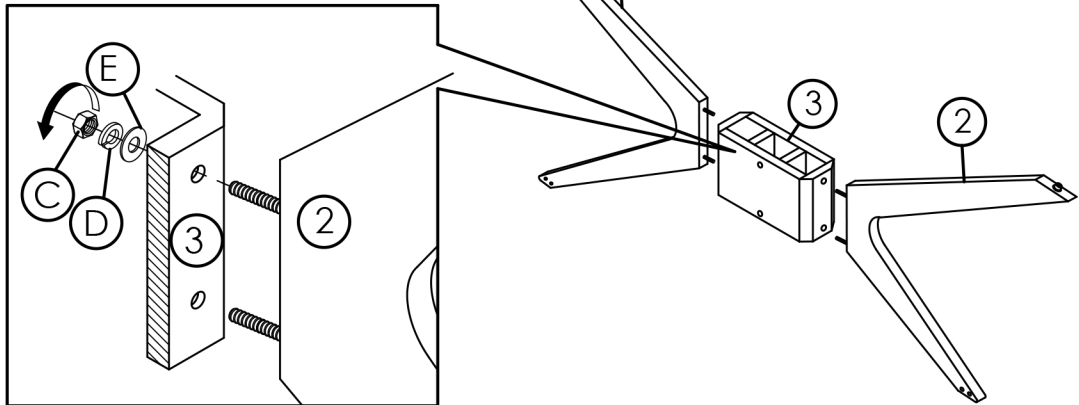

2

ATTENTION:
DO NOT FULLY TIGHTEN THE HEX NUTS

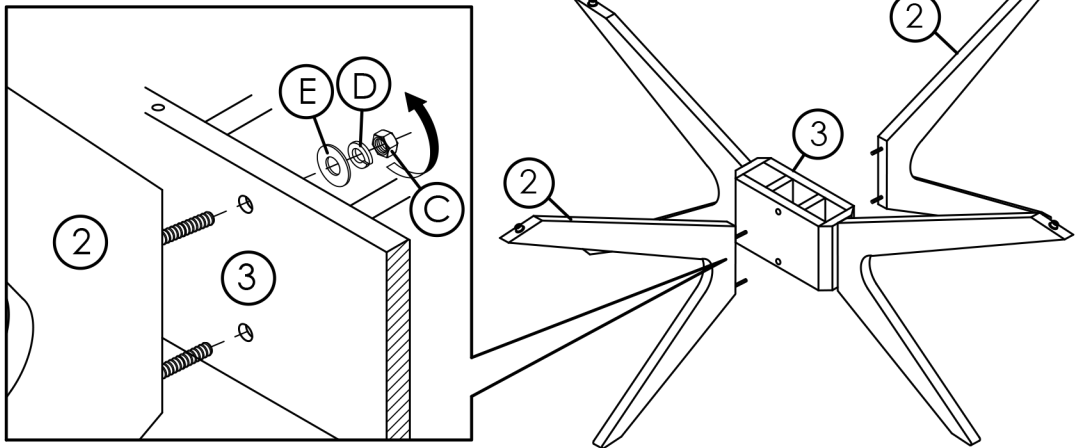

3

ATTENTION:
DO NOT FULLY TIGHTEN THE BOLTS

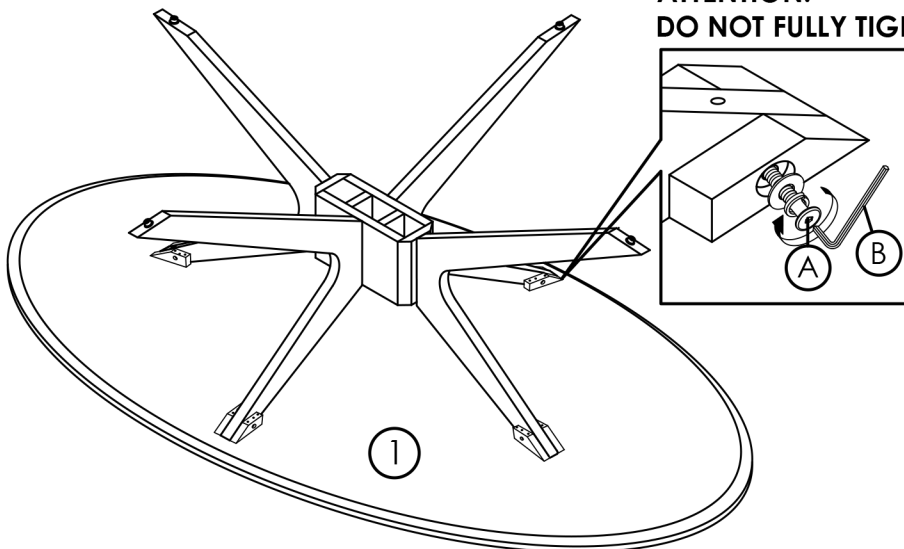

ASSEMBLY INSTRUCTIONS

4

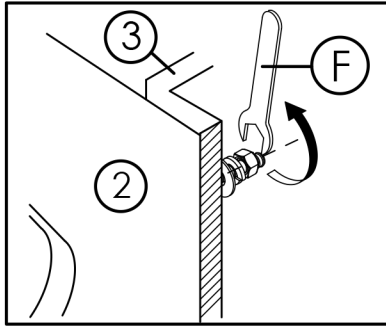

**ATTENTION:
FULLY TIGHTEN BOLTS,
HEX NUTS AND SCREW**

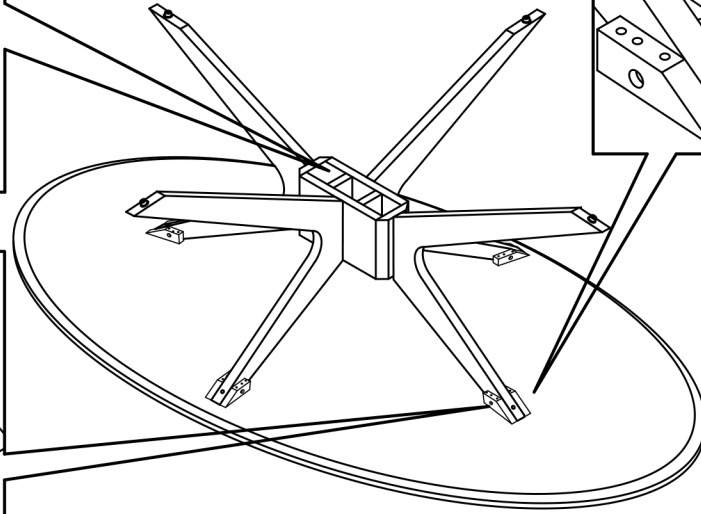
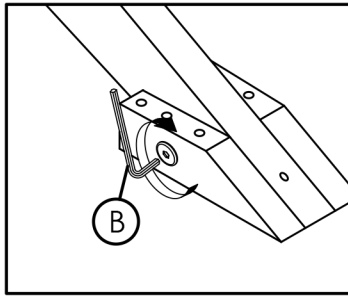
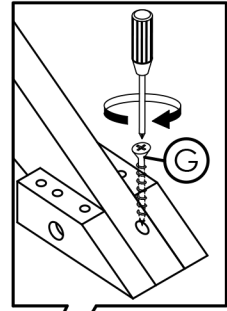

5

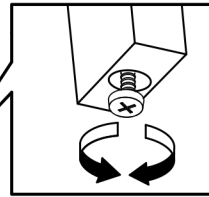
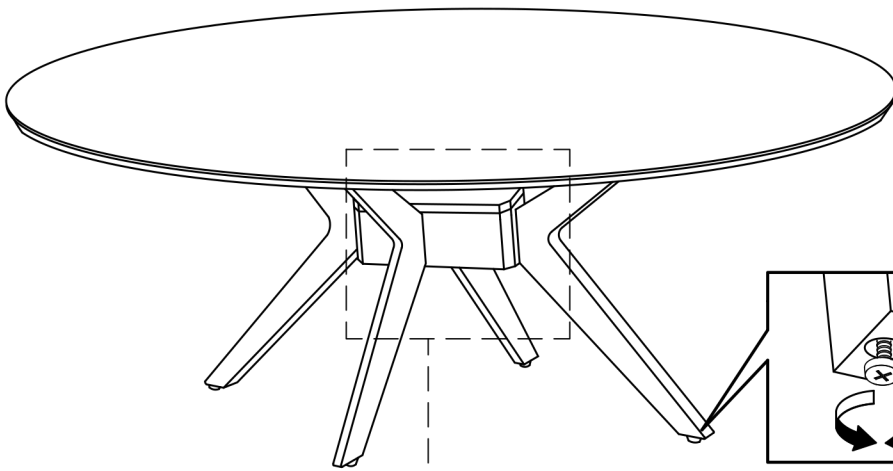

Turn clockwise or anti-clockwise
to adjust leg leveller.

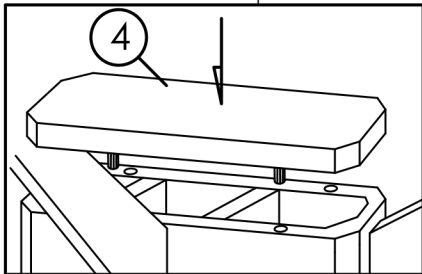

ASSEMBLY COMPLETED

Please ensure the furniture rests on an even and flat surface. If the product wobbles or feels loose, double-check all bolts and/or screws are properly tightened and secured.



✓ Keep this handy!

Please retain this instruction manual and any order-related information for future reference.

✓ Lift, don't drag!

To avoid damage to product please always LIFT the product when transporting or adjusting the placement.

This product is intended for RESIDENTIAL USE ONLY and not for commercial use.

ASSEMBLY INSTRUCTIONS

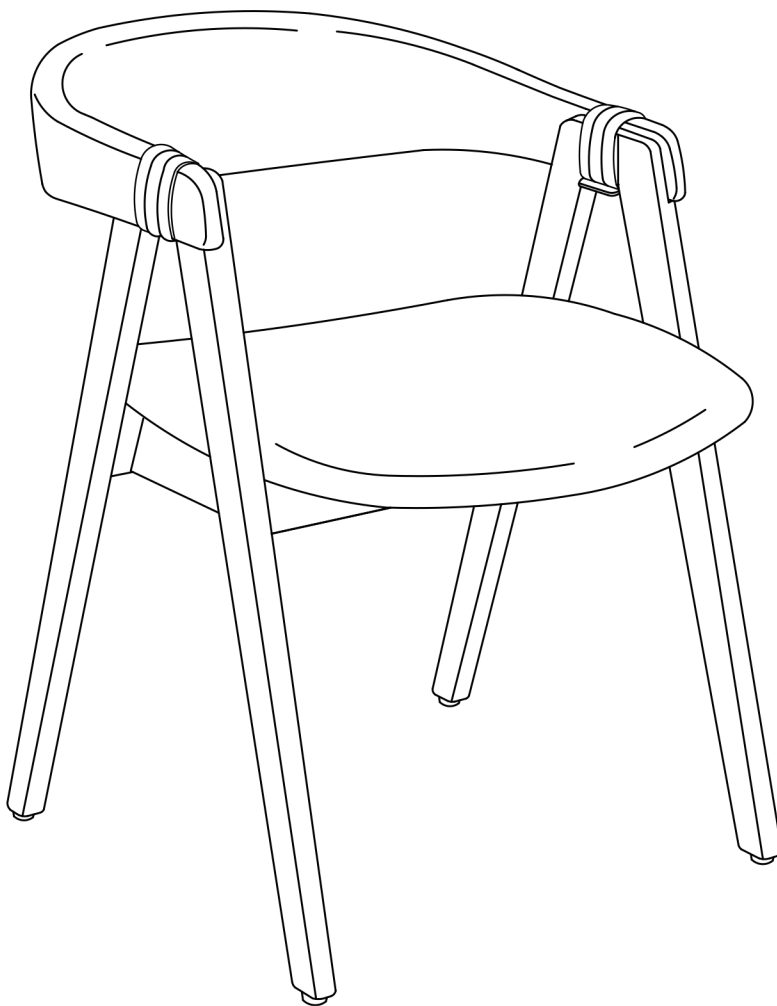

TOOLS REQUIRED



Screwdriver
(Not included)



Allen Wrench
(Included)



2 - People

ASSEMBLY RATING



EASY → DIFFICULT

The Assembly Rating is a 5-point system showing the level of the effort needed to assemble a specific product.



CHECK BEFORE STARTING

Are you missing anything?

Double-check all parts, hardware and accessories listed are all accounted for.

Should we send any replacements?

Are there any irregularities or flaws in the parts? We can send replacements!

Check out our Quick Tips!

We recommend reviewing the pre-assembly handouts. Even experts need a refresher now and then!

Prep Time!

Please review the assembly instructions and all diagrams prior to assembling.

PRE ASSEMBLY INSTRUCTION

We understand building ready-to-assemble furniture can be a challenging experience for some. To help avoid confusion, we have provided some helpful tips that may speed up the process.

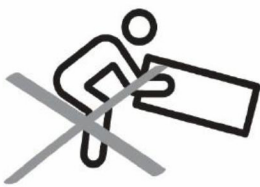

Teamwork

ALWAYS have at least two people to help with transporting and assembling the product to avoid potential injury and/or damage.



Suitable Location

Assembling near the area of the intended location is highly recommended.



Sufficient Space

Make sure you have enough space to move around during the assembly.



Avoid Scratches

Use cardboard, blankets or a carpeted area while assembling furniture to prevent scratches and damages.



Flat Surface

Make sure the furniture rests on a flat and level surface with each leg evenly touching the floor.

ASSEMBLY AND CARE ADVICE



FAILURE TO FOLLOW THE GUIDELINES BELOW MAY RESULT IN INJURY AND/OR PROPERTY DAMAGE.



Position each part correctly, and insert screws or bolts into their respective holes.

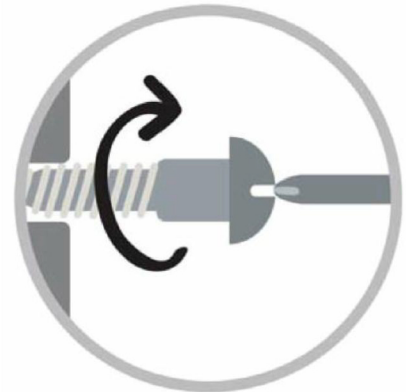

Turn clockwise to tighten and only tighten when step is completed or when instructed to do so.



Use the appropriate handtools or powertools for assembly. Select steps, such as tightnrning screws and/or bolts, may require handtools to avoid causing damage during assembly.



Save the instruction and store any supplied tools for later maintenance.



After two weeks, check and tighten any loose hardware and repeat again every six months thereafter.

IT IS THE USER'S RESPONSIBILITY MAINTAIN THE FURNITURE. THE HARDWARE MAY LOOSEN OVER TIME AND MAY CAUSE THE FURNITURE TO WOOLBY AND UNABLE TO SUPPORT ITS INTENDED WEIGHT CAPACITY. THIS MAY LEAD TO COLLAPSE AND MAY USE SERIOUS INJURY.

SIDE CHAIR



- Please keep instructions for future reference.
- Check the quantity and irregularity of parts and hardware before you start.

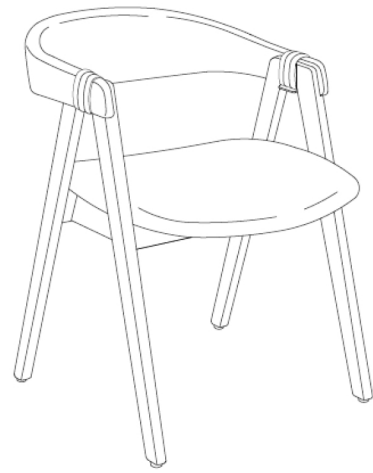

PARTS

1

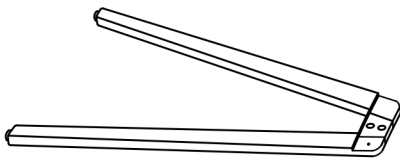

SIDE FRAME (LEFT)
1pc. x2

2

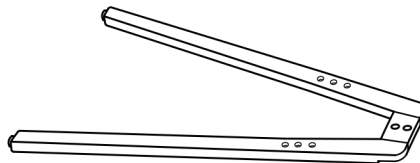

SIDE FRAME (RIGHT)
1pc. x2

3



BOX FRAME
1pc. x2

4



TOP REST
1pc. x2

5



CUSHION SEAT
1pc. x2

HARDWARE

A

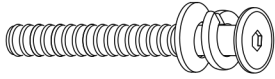

JCBC M6 x 70mm + S/W M6
+ F/W M6 x 13mm
4pcs. x2

B

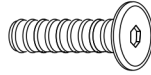

JCBC M6 x 25mm
4pcs. x2

C

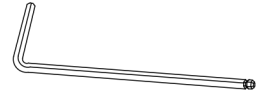

ALLEN KEY M4
(BALL SHAPE)
1pc.

D

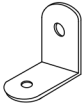

L BRACKET
4pcs. x2

E



PH SCREW M4 x 12mm
8pcs. x2

F



WOOD DOWEL M8 x 25mm
2pcs. x2

ASSEMBLY INSTRUCTIONS

1

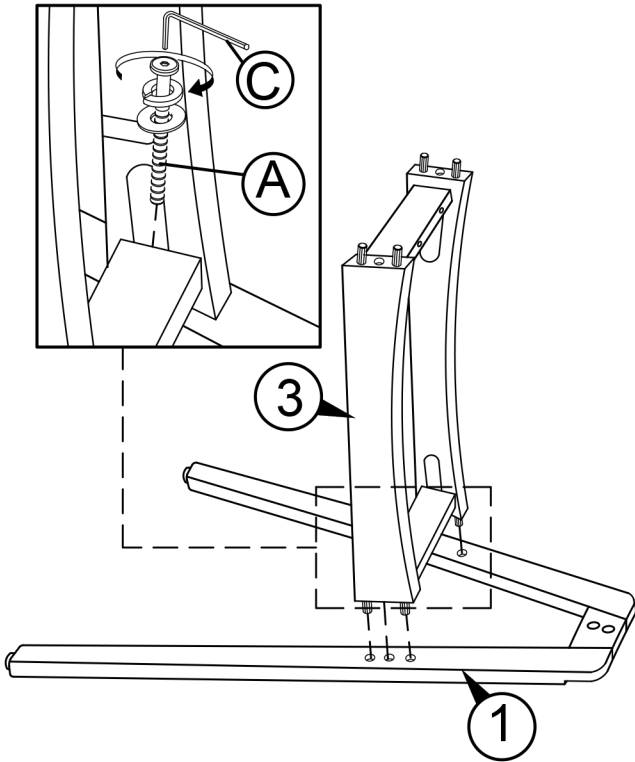

ATTENTION:
DO NOT FULLY TIGHTEN THE BOLTS

2

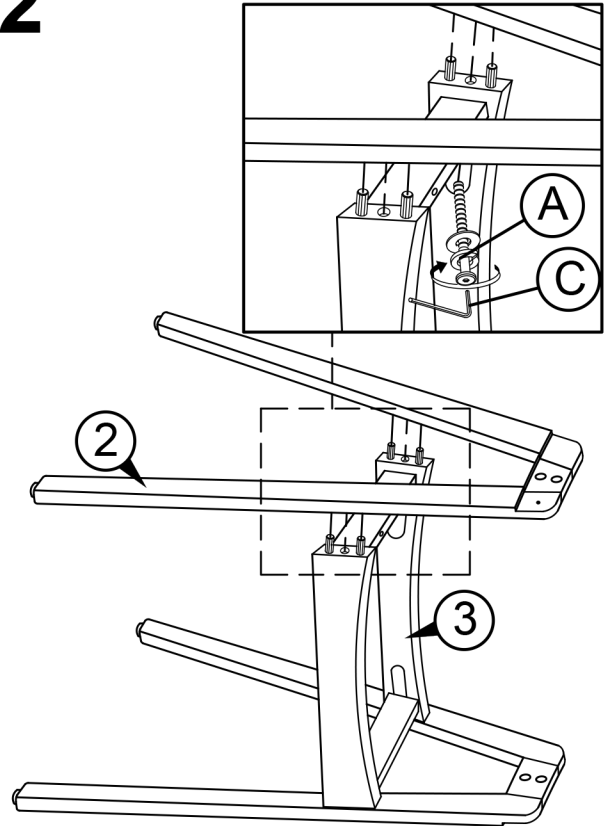

ATTENTION:
DO NOT FULLY TIGHTEN THE BOLTS

3

Small hole for Front Leg identification.

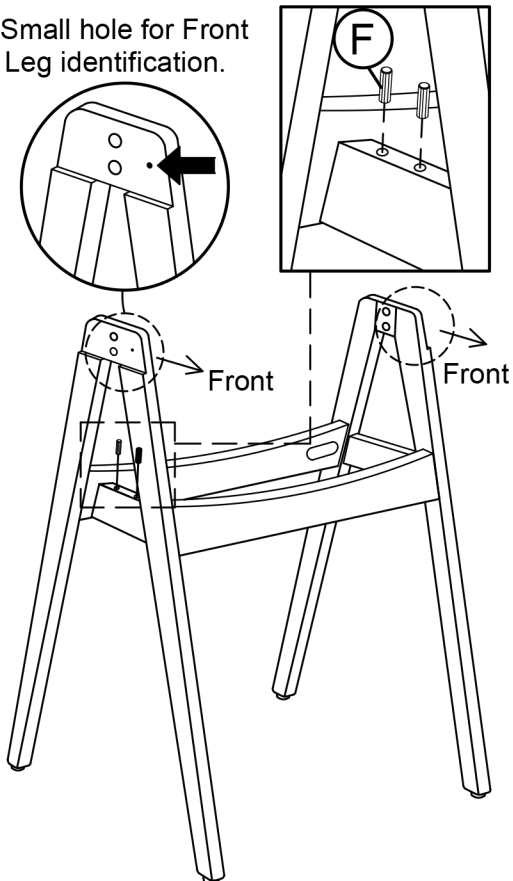

4

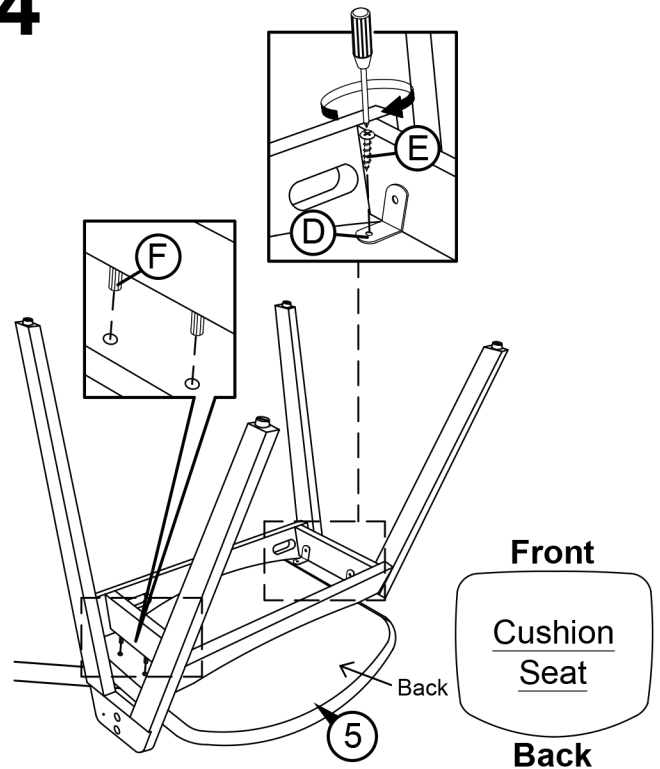

ATTENTION:
PLEASE FULLY TIGHTEN
THE BOLTS AND SCREWS

ASSEMBLY INSTRUCTIONS

5

ATTENTION:
PLEASE FULLY
TIGHTEN BOLTS

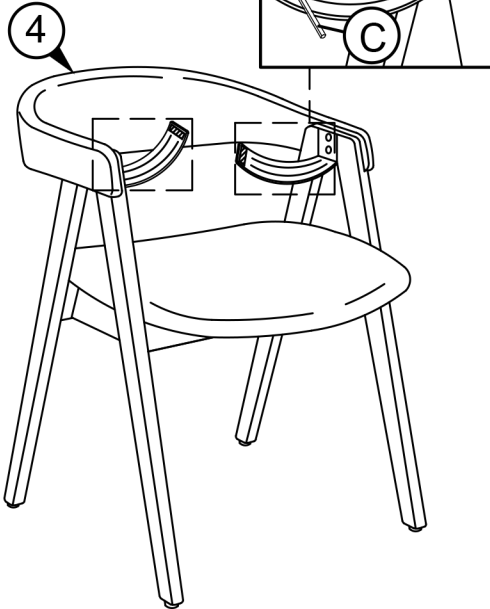

6

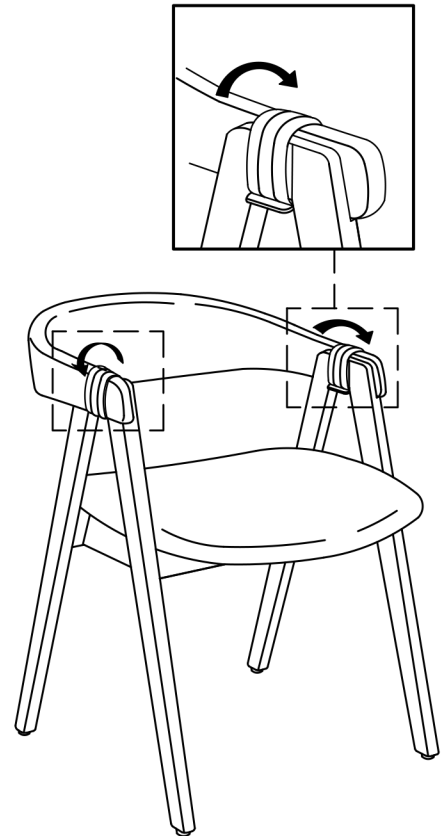

7

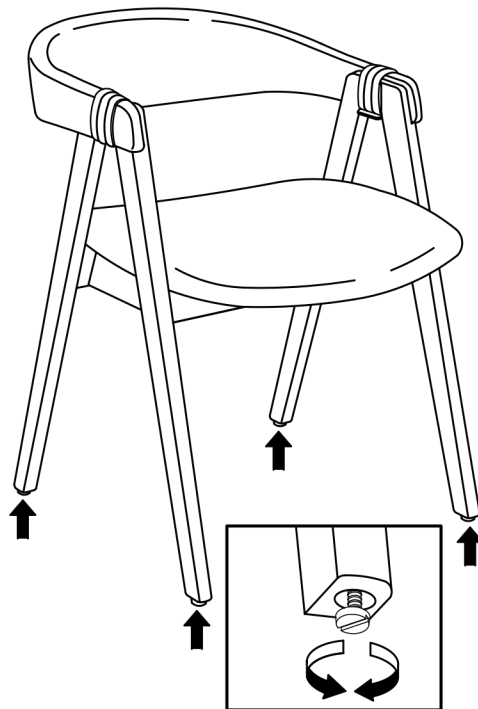

Turn clockwise or anti-clockwise
to adjust leg leveller.

ASSEMBLY COMPLETED



Please ensure the furniture rests on an even and flat surface. If the product wobbles or feels loose, double-check all bolts and/or screws are properly tightened and secured.



Keep this handy!

Please retain this instruction manual and any order-related information for future reference.



Lift, don't drag!

To avoid damage to product please always LIFT the product when transporting or adjusting the placement.

This product is intended for RESIDENTIAL USE ONLY and not for commercial use.