

Assembly Instructions

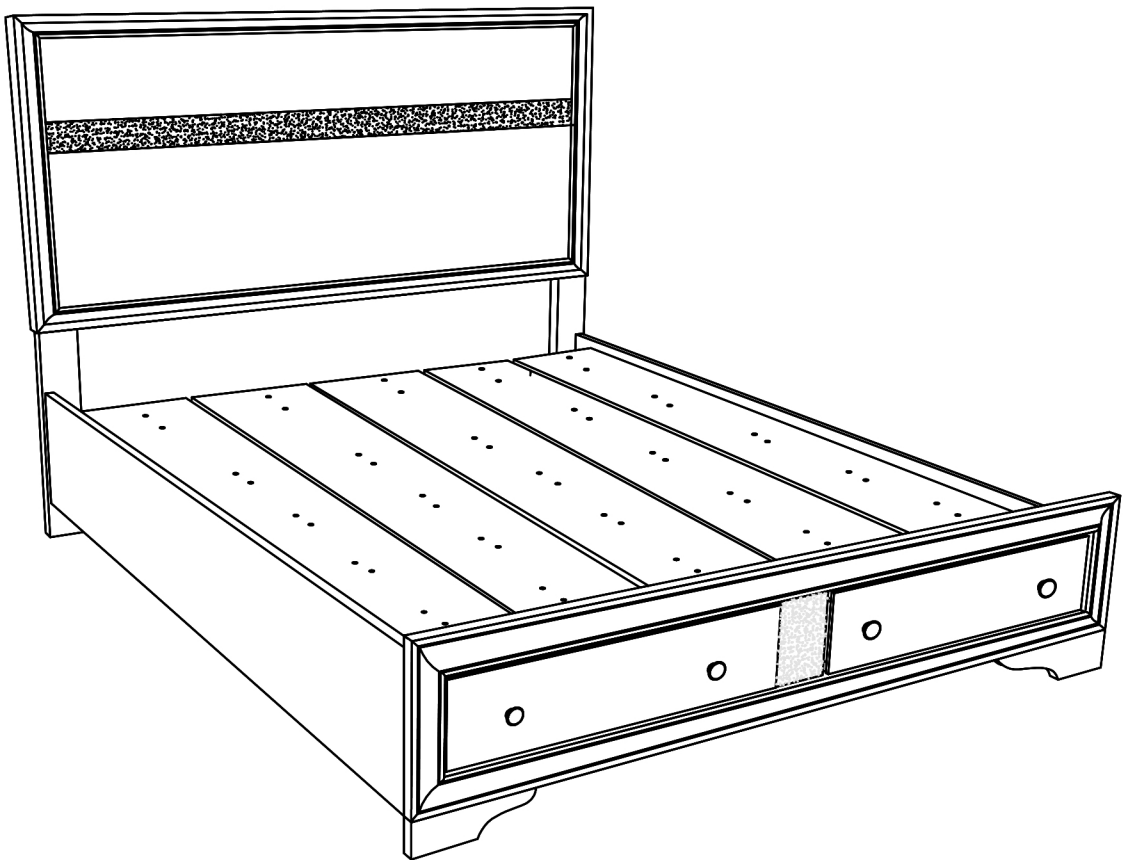

ASSEMBLY RATING

The Assembly Rating is a 5-point system that shows the degree of effort needed in assembling a specific product (with 1 being easy and 5 being difficult). For some products, two persons are recommended.

EASY  DIFFICULT

Tools Required For Assembly:

Allen Wrench

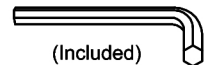

(Included)

Phillips Screwdriver



(Not Included)



2 PERSONS RECOMMENDED

ASSEMBLY & CARE ADVICE

FOR YOUR FURNITURE TO LAST, CORRECT ASSEMBLY AND PROPER MAINTENANCE ARE NECESSARY. PLEASE FOLLOW THE INFORMATION PROVIDED BELOW TO FULLY ENJOY YOUR FURNITURE.

BASIC ASSEMBLY TECHNIQUES

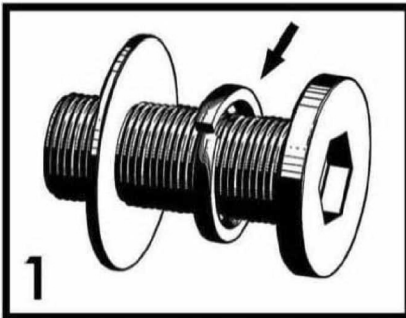

When lock or spring washer is used in an assembly, please make sure the lock or spring washer is placed between the larger flat washer and the head of the screw or bolt.

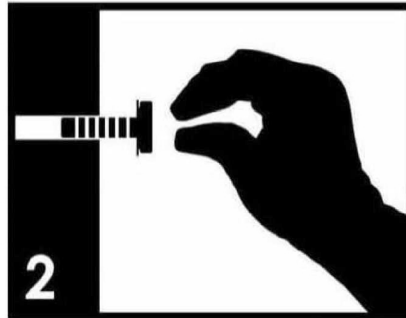

Position each part correctly and insert screws or bolts into their respective holes by hand tighten or using the proper hand tool. Only tighten when step is completed or when instructed to do so.

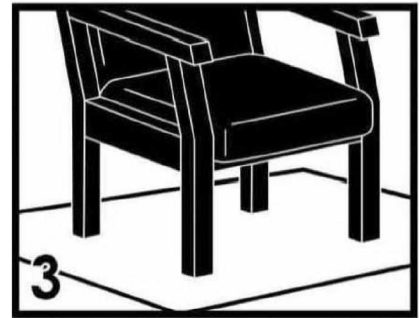

Use cardboard or carpet area when assembling furniture to prevent scratches. Make sure the furniture rests on a flat and level surface with each leg evenly touching the floor. No dragging of products/parts.

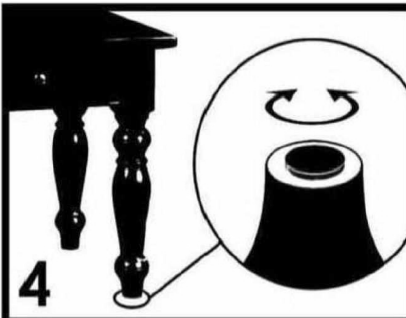

Some furniture comes with height adjustment knobs underneath each leg. To lower or to raise each leg, you need to turn clockwise or counterclockwise, respectively.

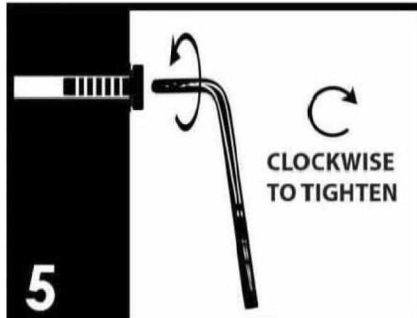

Make sure all parts are properly aligned, then use the appropriate hand tool to completely tighten the bolts or screws. Do not use power tools and do not overtighten.

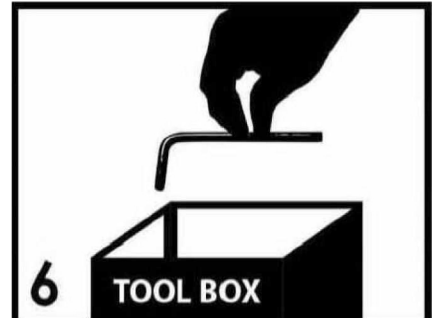

Save the instructions and store the Allen wrench or any supplied tool for later maintenance. After two weeks, check and tighten any loose hardware and repeat again every six months thereafter.

IT IS THE USER'S RESPONSIBILITY TO MAINTAIN THE FURNITURE. THE HARDWARE MAY LOOSEN OVER TIME AND MAY CAUSE THE FURNITURE TO BE WOBBLY AND UNABLE TO SUPPORT ITS INTENDED WEIGHT CAPACITY. THIS MAY LEAD TO COLLAPSE AND MAY CAUSE SERIOUS INJURY.



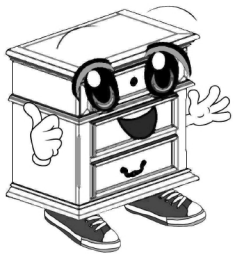

FAILURE TO FOLLOW THE GUIDELINES ABOVE MAY RESULT IN INJURY AND/OR PROPERTY DAMAGE.









Before you begin, please read Page 2 of "Assembly and Care Advice".

And remember, do not tighten until each step is completed or instructed.

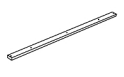
Parts List (Box 1) Headboard Box

-  #1 x 1pc
Headboard
-  #2 x 1pc
Footboard
-  #3 x 2pcs
Headboard Leg L/R

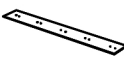

Parts List (Box 2) Side Rail Box

-  #4 x 2pcs
Side Rail
-  #5 x 1pc
Center Slat Drawer
-  #6 x 3pcs
Bed Slat w/o marking
1545 x 45 x 18mm
-  #7 x 2pcs
Bed Slat with marking
1545 x 45 x 18mm
-  #8 x 5pcs
Bed Slat Support
320 x 30 x 30mm
-  #9 x 1pc
Drawer Slat Support
95 x 30 x 30mm
-  #10 x 2pcs
Drawer Support Rail
633 x 40 x 20mm
-  #11 x 5pcs
Concealed Panel
2040 x 295 x 9mm

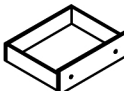



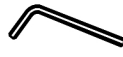

Parts List (Box 3) Drawer Box

-  #12 x 2pcs
Footboard Drawer

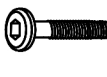
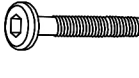
Hardware List (Box 1) Headboard Box

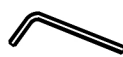
-  #A x 6pcs
Bolt 1/4" x 1-2/8"
-  #B x 6pcs
Lock Washer
-  #C x 6pcs
Flat Washer
-  #D x 1pc
Allen Key m4

Hardware List (Box 2) Side Rail Box

-  #E x 2pcs
Bolt 1/4" x 1-3/8"
-  #F x 6pcs
Bolt 1/4" x 2"
-  #G x 2pcs
Lock Washer
-  #H x 2pcs
Flat Washer
-  #I x 1pc
Allen Key m4
-  #J x 1pc
Allen Key m5
-  #K x 14pcs
CSK m4 x 32mm
-  #L x 25pcs
P.H Screw m3.5x20mm



#1

Prepare 6 bolts assembly by inserting lock washer (#B), then flat washer (#C) onto bolts (#A).
Align HB legs (#3R/L) to the holes of the headboard (#1). Secure by using bolts (#A).

#A x 6pcs
#B x 6pcs
#C x 6pcs

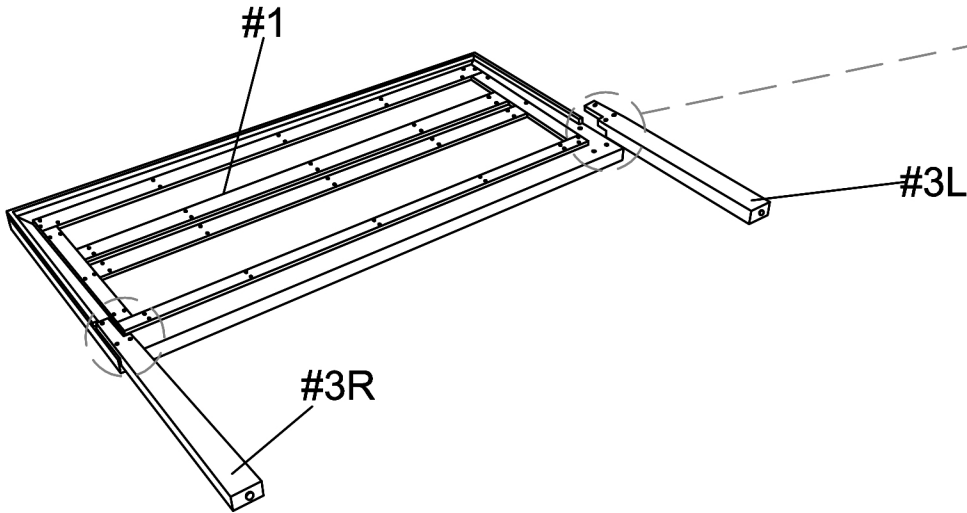
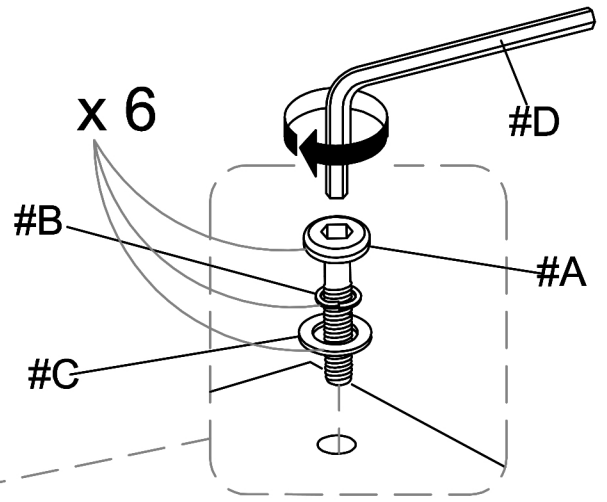

#2

1) Loosen the bolts attached to headboard (#1) and footboard (#2), then hook the side rails (#4) to the loosened bolts on the headboard (#1) and footboard (#2).
2) Tighten the bolts on the headboard (#1) and footboard (#2) to the side rail hooks (#4).

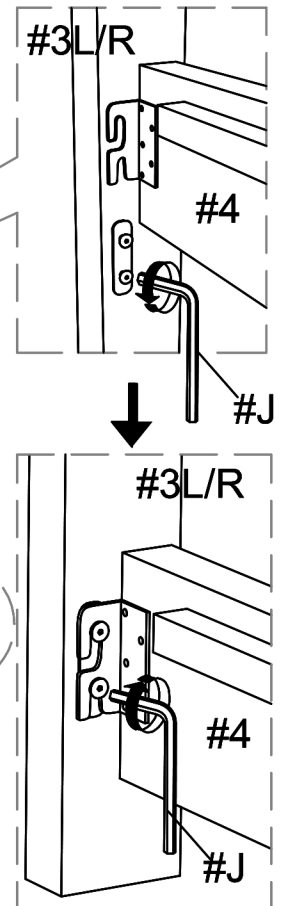
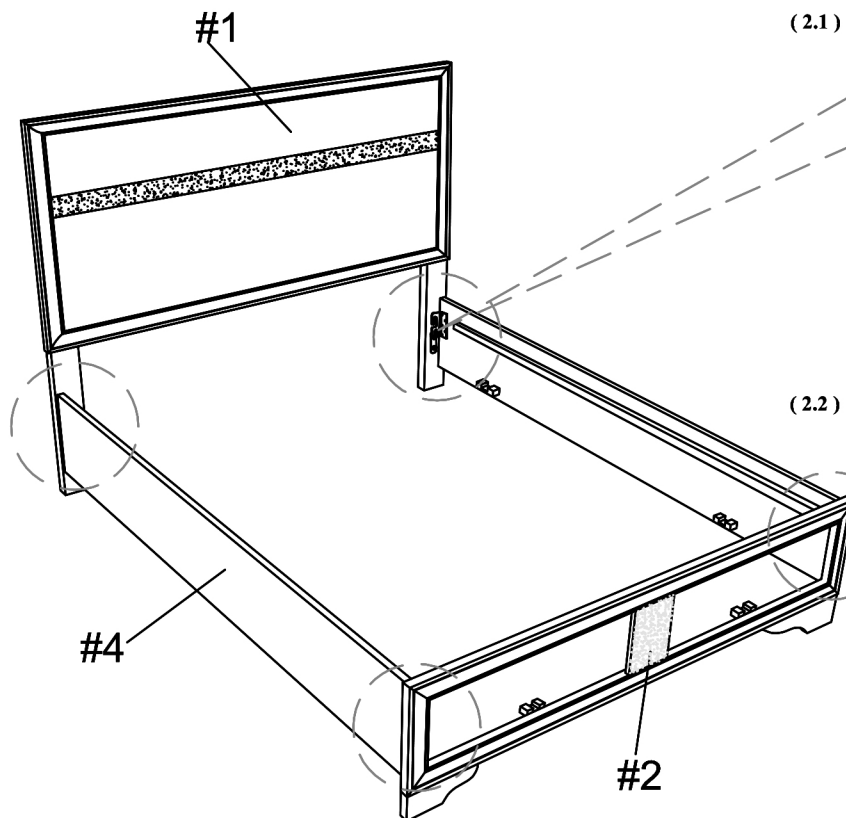



#3

Align center slat drawer (#5) to the side rails (#4), then secure by using screws (#K).

#K x 2pcs

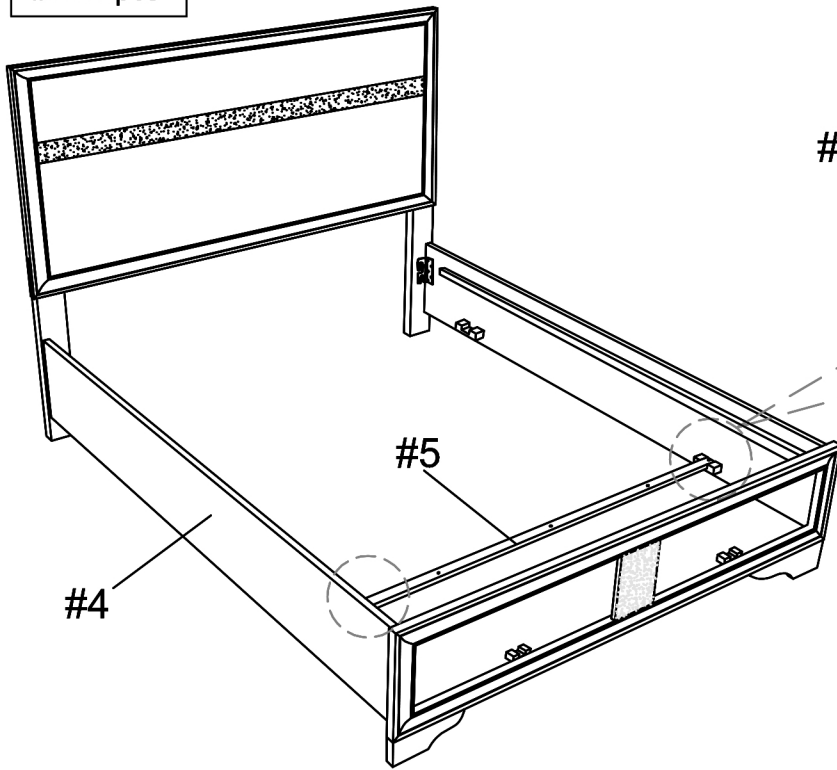

x 2

#4

#K

#5

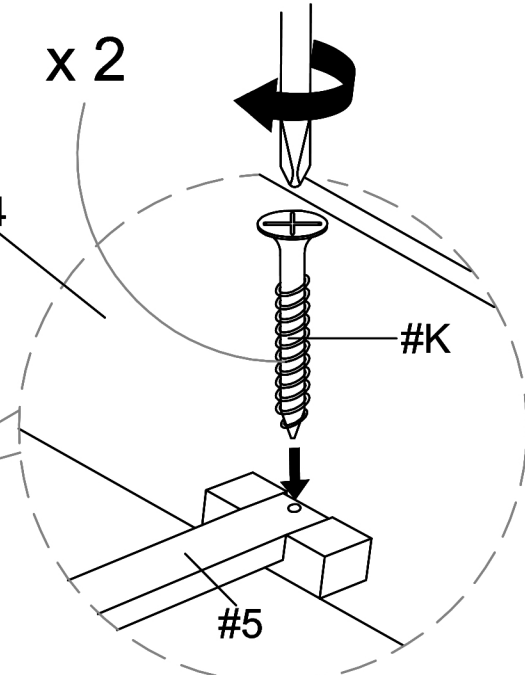

#4

Align support leg (#9) to the hole of the center slat drawer (#5), then adjust leveler of the support leg (#9) according to ground level.

#F x 1pc

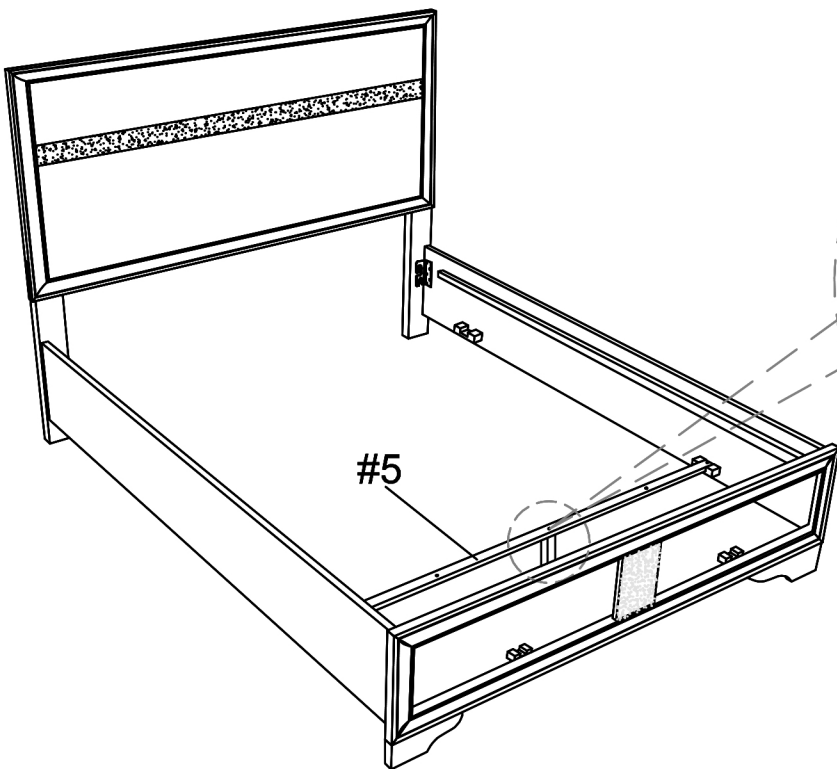

x 1

#1

#F

#5

#9

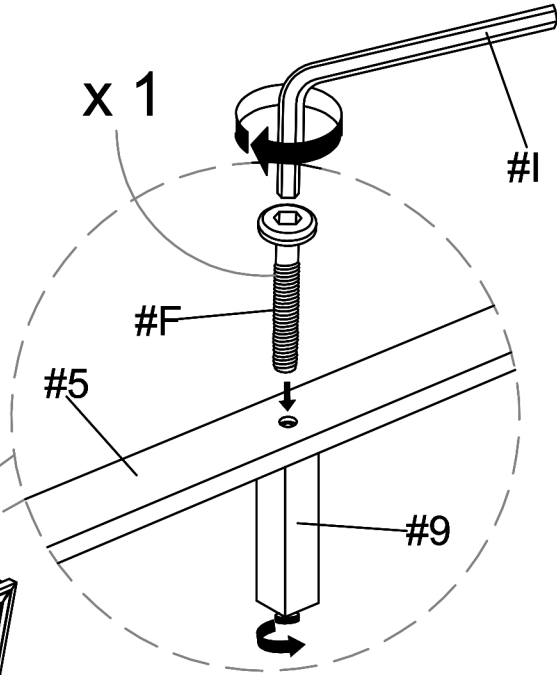



#E x 2pcs
 #G x 2pcs
 #H x 2pcs
 #K x 2pcs

x 2

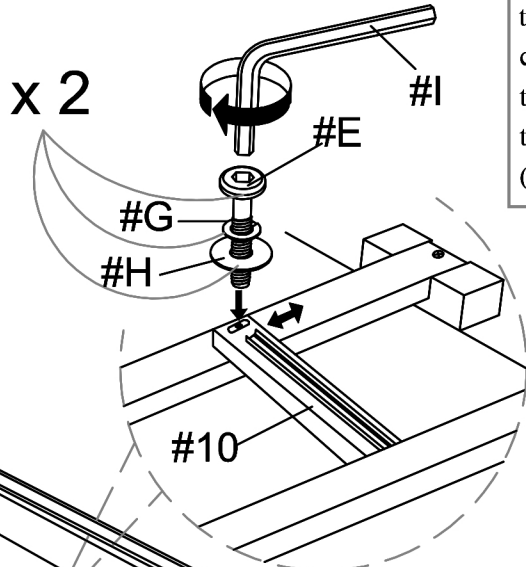
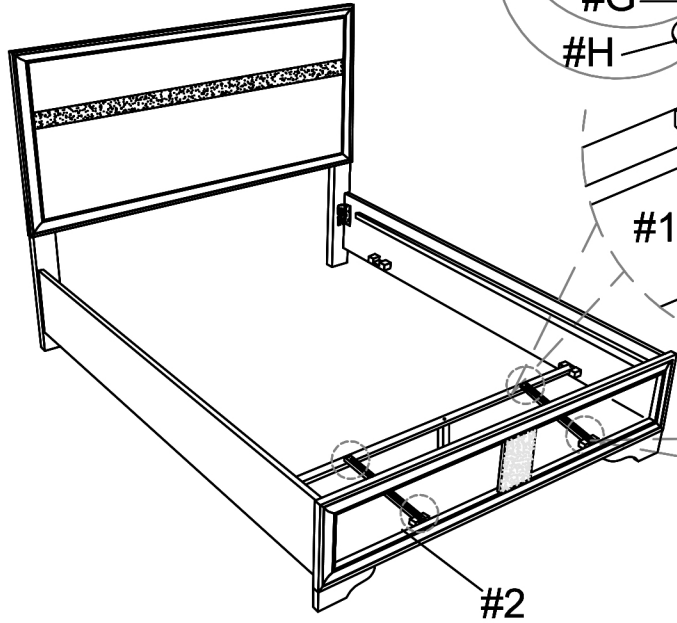

Prepare 2 bolts assembly by inserting lock washer (#G), then flat washer (#H) onto bolts (#E). Align drawer support rail (#10) to the holes of the footboard (#2) and center slat (#5). Secure drawer rail (#10) to center slat (#5) by using bolts (#E), then secure drawer rail (#10) to footboard (#2) by using screws (#K).

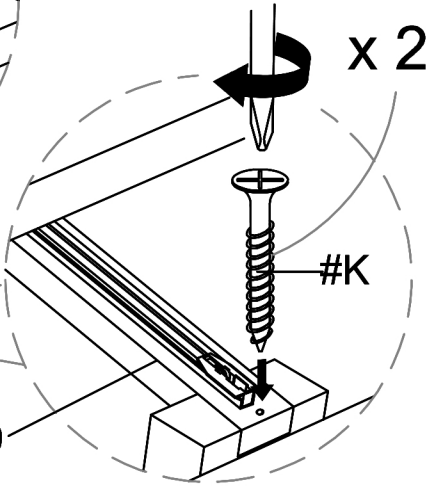

Unscrew knobs on the inside, then secure knobs to the outside of the drawers (#12).

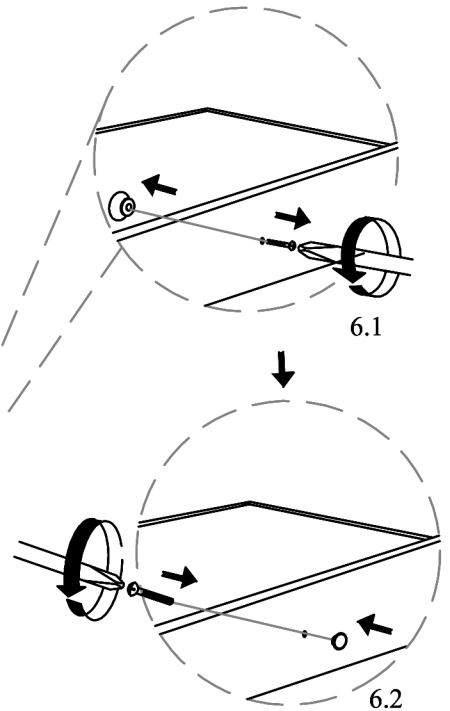
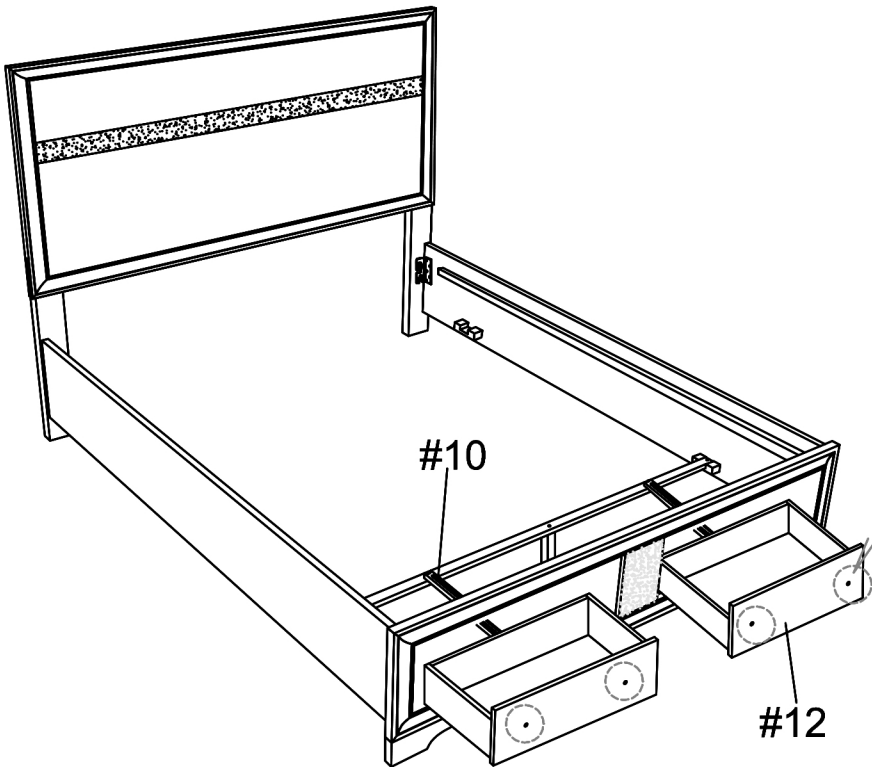



#F x 5pcs

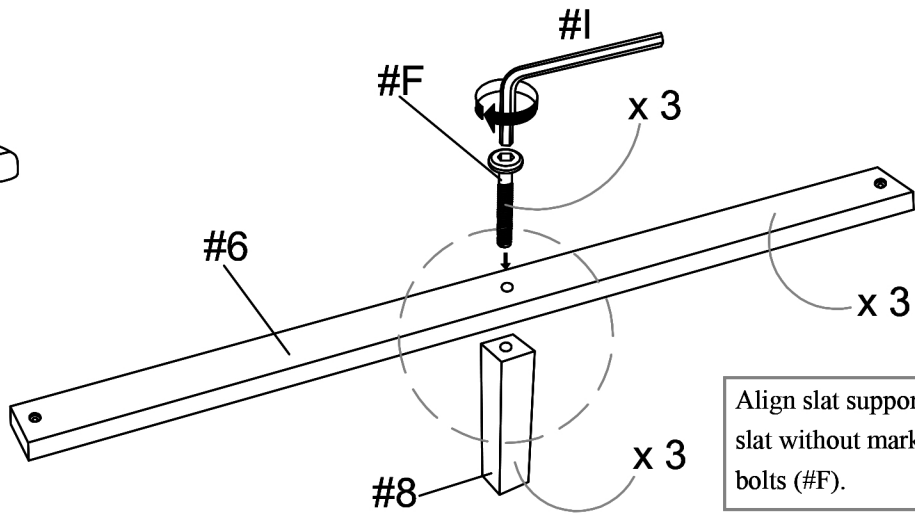

Align slat support (#8) to the hole of the bed slat without marking (#6). Secure by using bolts (#F).

Align slat support (#8) to the holes of the bed slat with marking (#7). Secure by using bolts (#F).

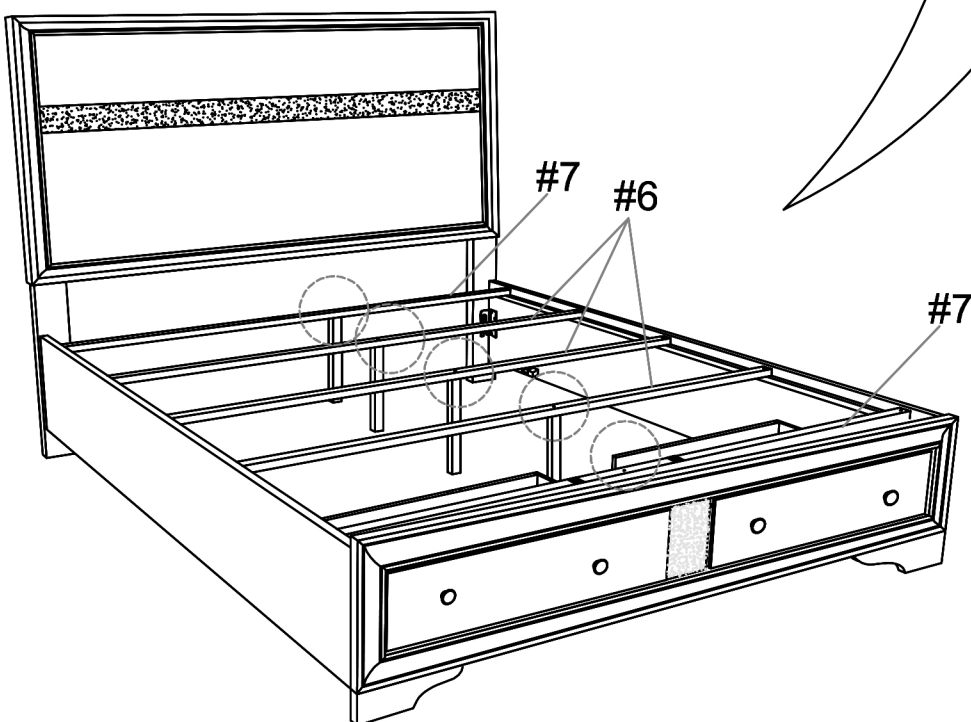
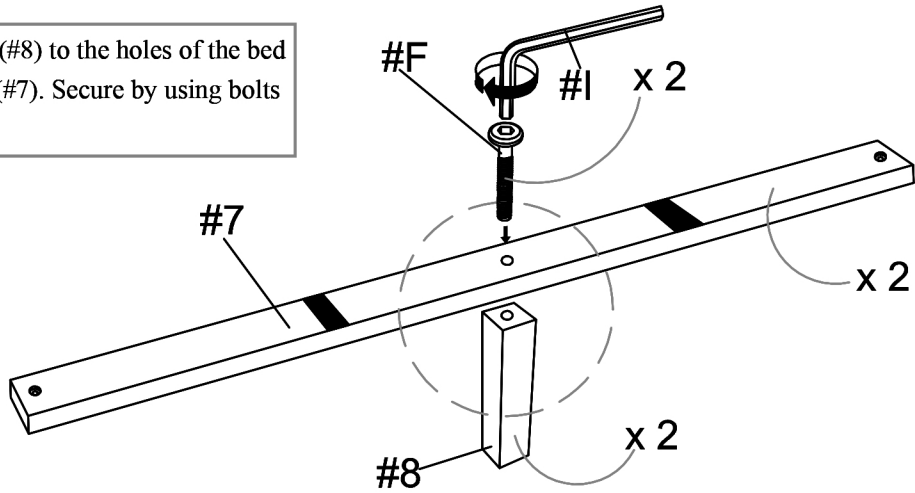

Align slats (#6,7) to the side rails (#4).



#8

Secure slats (#6,7) by using screws (#K).

#K x 10pcs

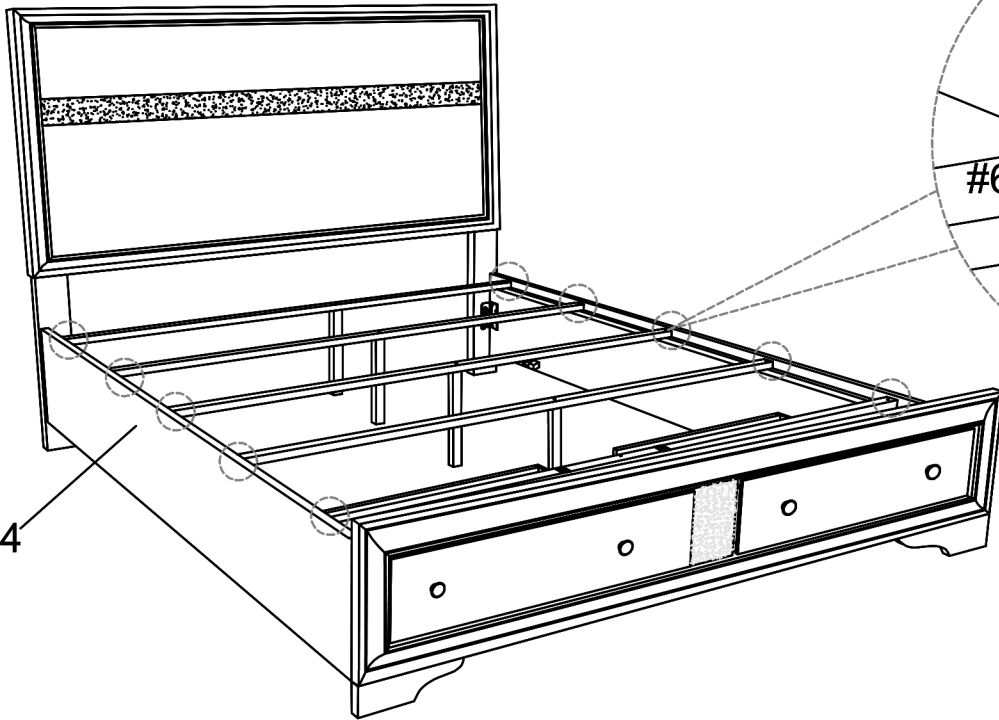

#4

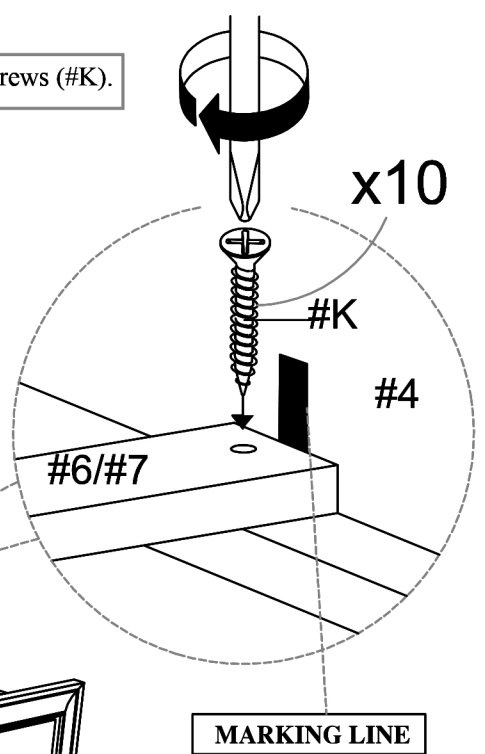

x10

#K

#4

#6/#7

MARKING LINE



#9

Align concealed panel (#11) to the slats (#6,7). Secure by using screws (#L).

#L x 25pcs

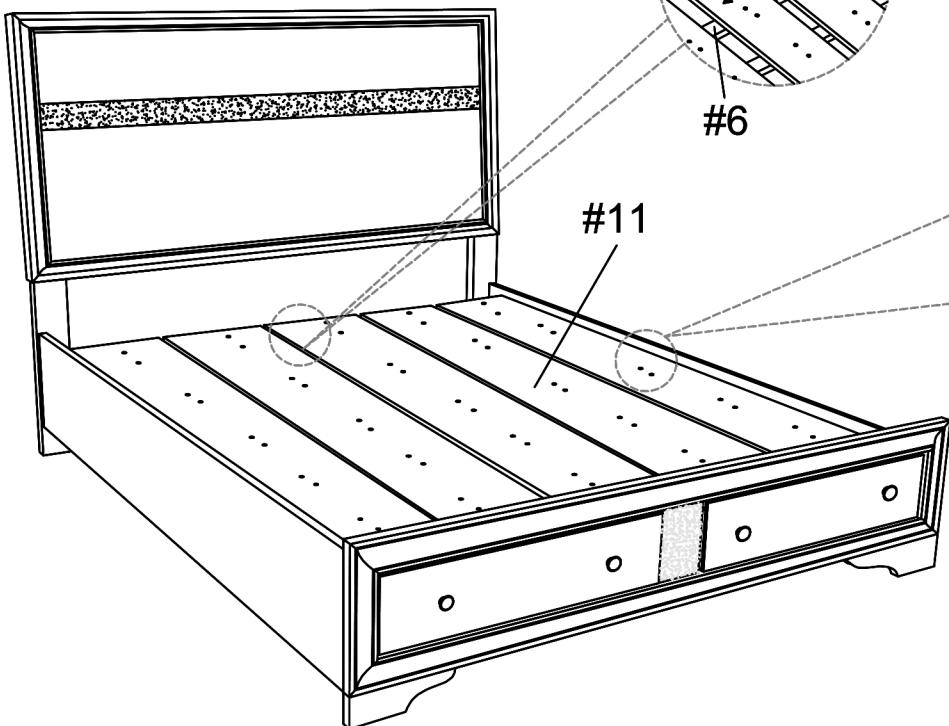

#7

#11

#6

#11

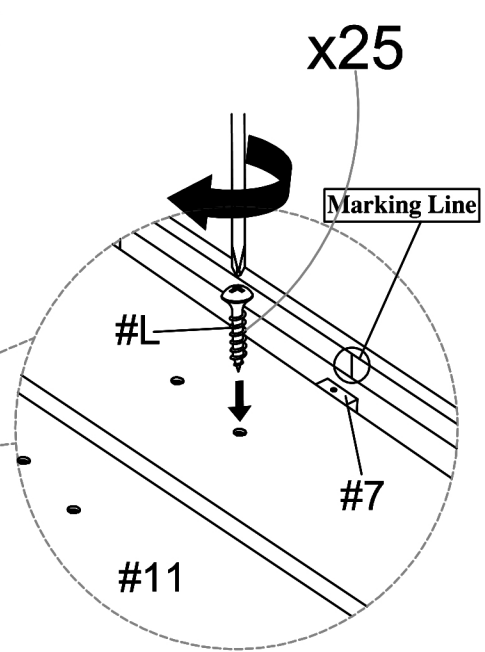

x25

Marking Line

#L

#7

#11

Please see diagram in steps 10.

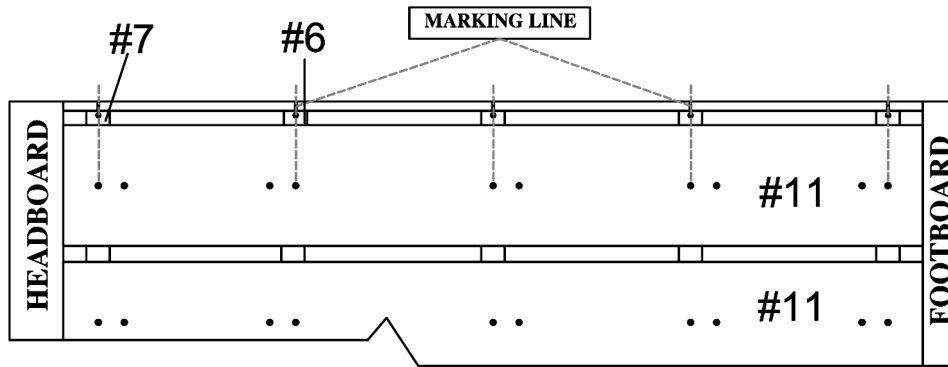

ASSEMBLY COMPLETED

