











Assembly Instructions for Dining Table

Remove protective materials and set parts on a flat, non-abrasive surface. Identify all parts packed in carton against the parts list. Do not attempt to assemble the table if any parts are missing or damaged.

Parts List

	Sketch	Description	Qty
A		Table top	1
B		Leg Connector	1
C		Table Leg	4
D	 M6*35	Bolt	4
E	 M6*50	Bolt	4
F	 M6	Washer	16
G	 M6	Nut	8
H	 M4X12	Bolt	4
I		Screw cap	8
J		Hole cover	1
K		Rubber mat	4
L	 M6	Wrench	1
M	 M6	Wrench	1

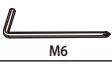
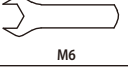
Step 1

Place Table Top (A) upside down on a non-abrasive surface to avoid scratching the top. Insert Rubber Mat (K) into hole and attach a Table Leg (C) to each corner of the table top. Screw Bolt (H) through the aligned holes and keep slightly loose. Some adjustments may be necessary to ensure the table legs are aligned properly.

Fig. 1

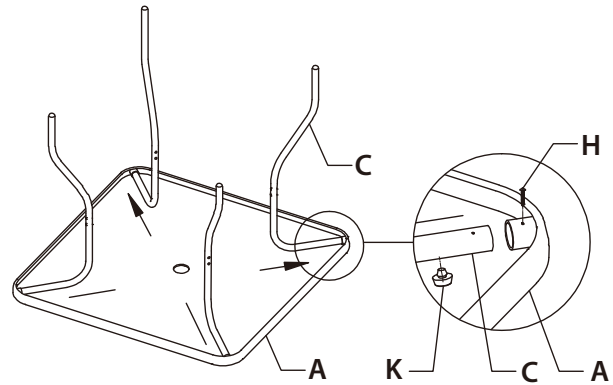

Step 2

Align the Leg Connector (B) within Legs (C).

Secure Bolt (D) and Washer (F) to the top-most hole of each Leg Connector with Nut (G).

Hand-tighten 3 - 4 revolutions only.

Secure Bolt (E) and Washer (F) to the bottom-most hole of each Leg Connector with Nut (G).

Hand-tighten 3 - 4 revolutions only.

Tighten all Bolts (D, E) with Wrench (K). Cover with Screw Cap (I).

Fig. 2

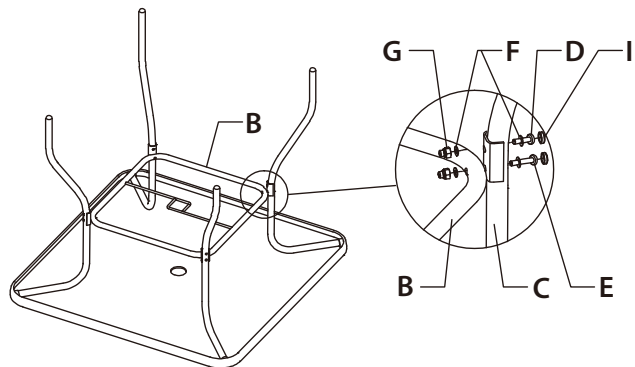

Step 3

With the help of another person, carefully turn the table upright. Tighten all Bolts (H) from Step 1. Place the Hole Cover (J) into the center hole. Your table is now ready to be used.



Fig. 4

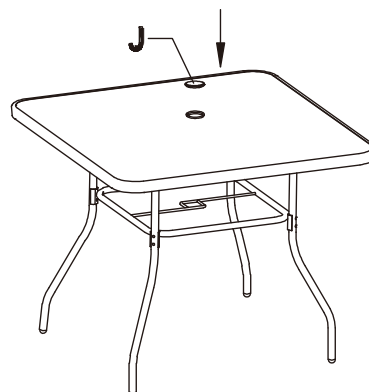

Fig. 3