

ASSEMBLY INSTRUCTIONS

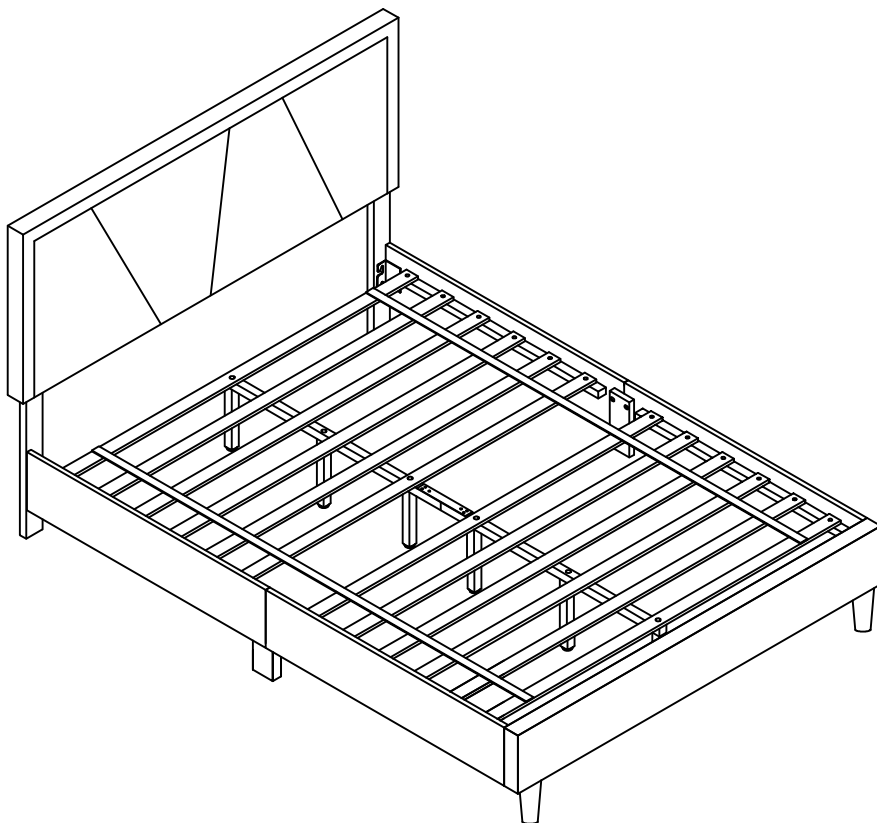

TOOLS REQUIRED



Allen Wrench

(Included)

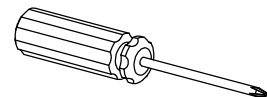

Phillips Screwdriver

(Not Included)



3 - People
Recommended

ASSEMBLY RATING



EASY —————> DIFFICULT

The Assembly Rating is a 5-point system showing the level of effort needed to assemble a specific product.



CHECK BEFORE STARTING

Are you missing anything?

Double-check all parts, hardware and accessories listed are all accounted for.

Check out our Quick Tips!

We recommend reviewing the pre-assembly handouts. Even experts need a refresher now and then!

Should we send any replacements?

Are there any irregularities or flaws in the parts? We can send replacements!

Prep Time!

Please review the assembly instructions and all diagrams prior to assembling.

PRE ASSEMBLY INTRODUCTION

We understand building ready-to-assemble furniture can be a challenging experience for some. To help avoid confusion, we have provided some helpful tips that may speed up the process.



Teamwork

ALWAYS have at least two people to help with transporting and assembling the product to avoid potential injury and/or damage.



Suitable Location

Assembling near the area of the intended location is highly recommended.



Sufficient Space

Make sure you have enough space to move around during the assembly.



Avoid Scratches

Use cardboard, blankets or a carpeted area while assembling furniture to prevent to prevent scratches and damages.



Flat Surface

Make sure the furniture rests on a flat and level surface with each leg evenly touching the floor.

ASSEMBLY AND CARE ADVICE



FAILURE TO FOLLOW THE GUIDELINES BELOW MAY RESULT IN INJURY AND/OR PROPERTY DAMAGE.



Position each part correctly and insert screws or bolts into their respective holes.



Turn clockwise to tighten and only tighten when step is completed or when instructed to do so.



Use the appropriate hand tools or power tools for assembly. Select steps, such as tightening screws and/or bolts, may require hand tools to avoid causing damage during assembly.



Save the instructions and store any supplied tools for later maintenance.



After two weeks, check and tighten any loose hardware and repeat again every six months thereafter.

IT IS THE USER'S RESPONSIBILITY TO MAINTAIN THE FURNITURE. THE HARDWARE MAY LOOSEN OVER TIME AND MAY CAUSE THE FURNITURE TO BE WOBBLY AND UNABLE TO SUPPORT ITS INTENDED WEIGHT CAPACITY. THIS MAY LEAD TO COLLAPSE AND MAY CAUSE SERIOUS INJURY.

BED



- Please keep instructions for future reference.
- Check the quantity and irregularity of parts and hardware before you start.

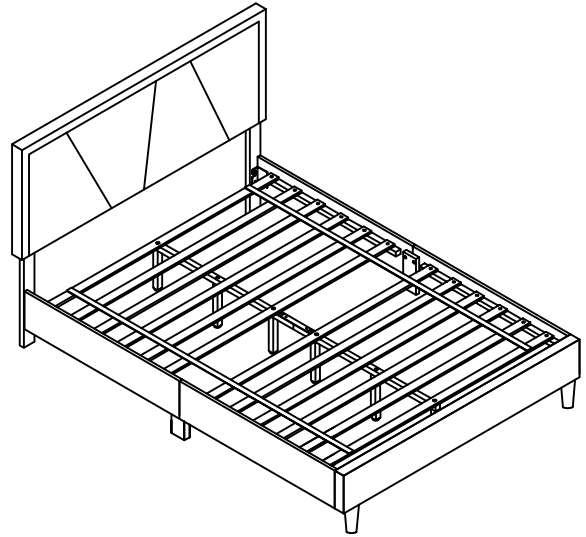

PARTS

#1 1pc

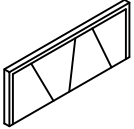

Headboard Panel

#2 1pc



Footboard

#3 2pcs



Side Rail A

#4 2pcs



Side Rail B

#5 2pcs

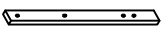

Headboard Leg

#6 2pcs



Footboard Leg

#7 6pcs

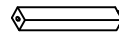

Support Leg

#8 2pcs

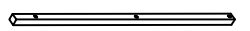

Center Support Tube

#9 2pcs



Side Rail Support panel

#10 1Set

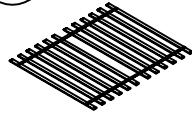

Slat (12pcs)

#11 4pcs



Side Rail Support Bar

BED



- Please keep instructions for future reference.
- Check the quantity and irregularity of parts and hardware before you start.

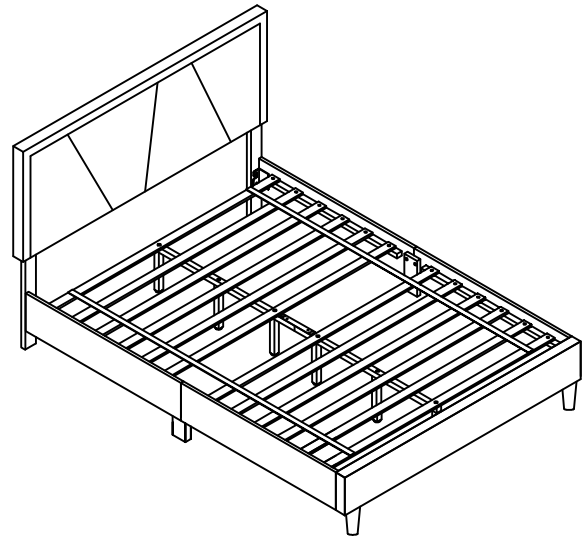

HARDWARE

#A 8pcs



Bolt 1/4" x 1-1/4"

#B 8pcs



Bolt 5/16" x 1-1/4"

#C 10pcs



Bolt 5/16" x 2-1/4"

#D 18pcs



Lock Washer Ø19mm

#E 18pcs



Flat Washer Ø19mm

#F 30pcs



Screw

#G 1pc



Allen Wrench Ø $\frac{5}{16}$ "

#H 1pc



Connect plate

#I 20pcs



Flat Washer Ø16mm

#J 20pcs



Lock Washer Ø16mm

#K 12pcs



Bolt 1/4" x 1-1/2"

#L 1pc



Allen Wrench Ø $\frac{1}{4}$ "

ASSEMBLY INSTRUCTIONS

1

Align the Headboard Leg (#5) to the Headboard Panel (#1) at your preferred height and secure by using Bolts (#C) with washers (#D,#E).

- Part #1 x1pc
- Part #5 x2pcs
- Hardware #C x4pcs
- Hardware #D x4pcs
- Hardware #E x4pcs

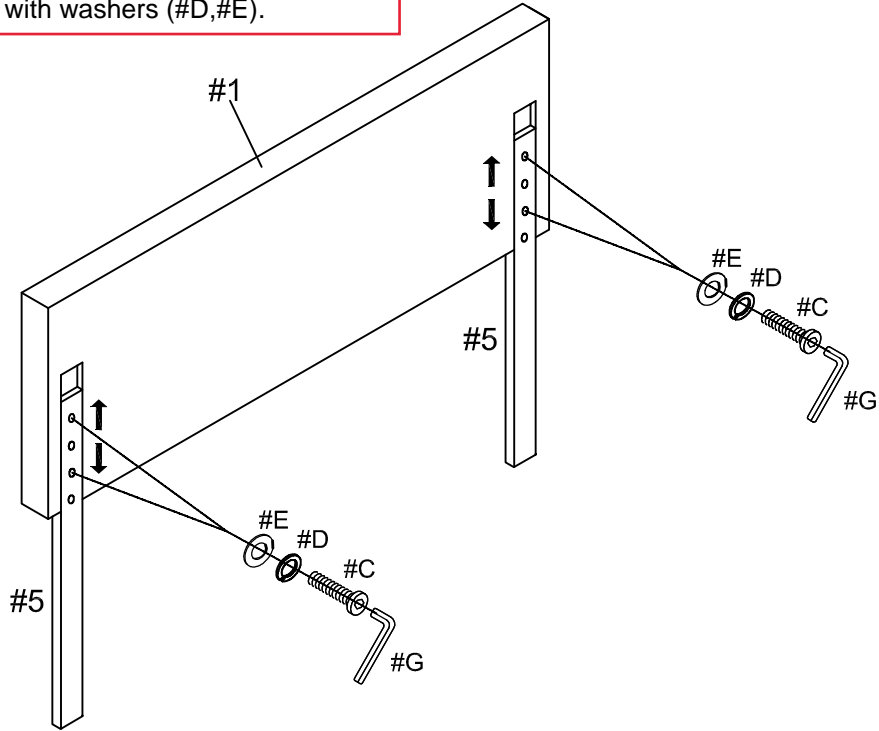

2

Attach the Footboard Leg (#6) to the Footboard (#2).

- Part #2 x1pc
- Part #6 x2pcs

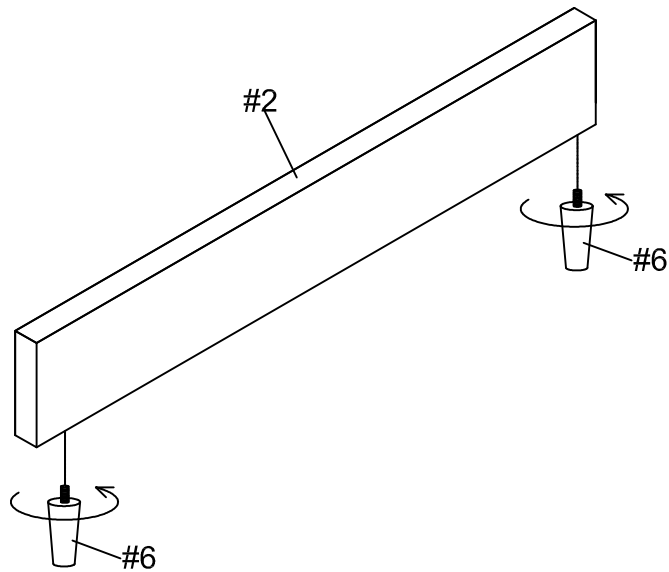

ASSEMBLY INSTRUCTIONS

3

- Part #3 x2pcs
- Part #4 x2pcs
- Part #11 x4pcs
- Hardware #A x 8pcs
- Hardware #K x 12pcs
- Hardware #I x 20pcs
- Hardware #J x 20pcs

I. Prepare Rails assembly by attaching the Side Rail Support Bar (#11) to the Side Rail A (#3) and Side Rail B (#4). Secure using Bolt (#K) with Washers (#J,#K).

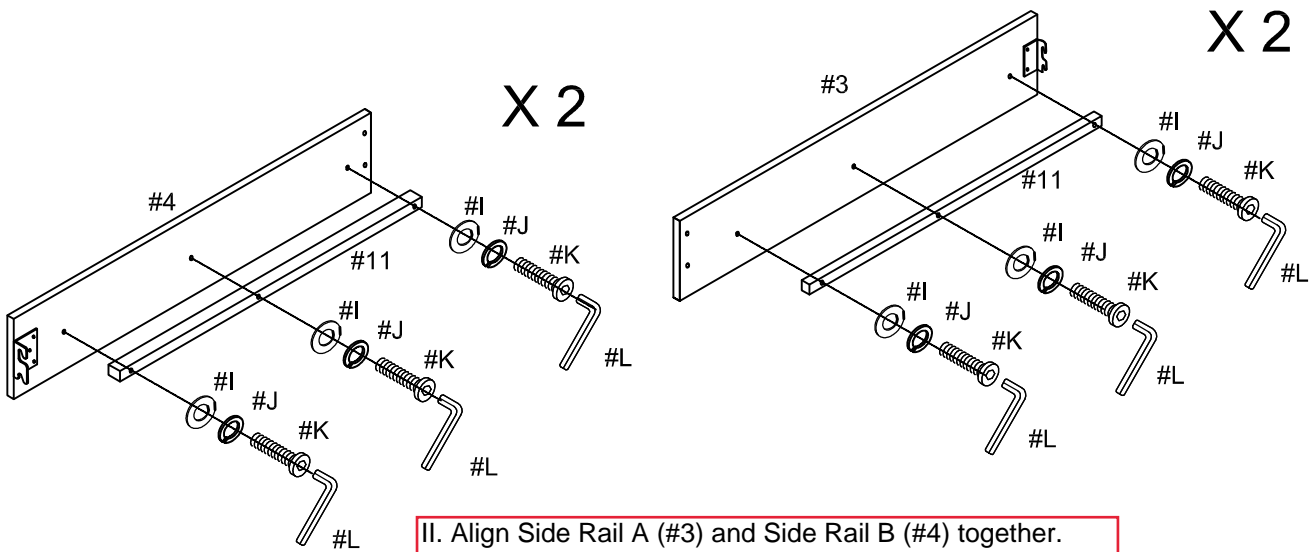

II. Align Side Rail A (#3) and Side Rail B (#4) together. Align the Side Rail Support panel (#9) over and secure all parts together using Bolts (#A) with Washers (#J, #I).

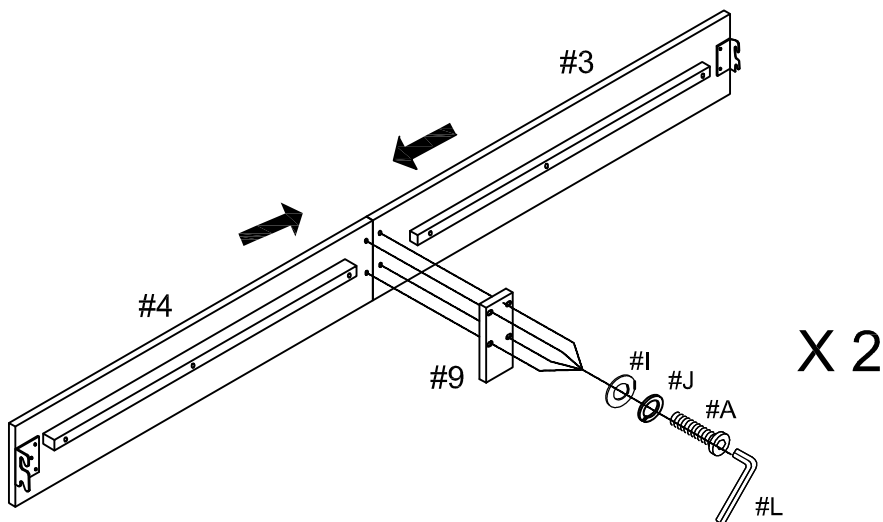

ASSEMBLY INSTRUCTIONS

4

- Hardware **#B** x 8pcs
- Hardware **#D** x 8pcs
- Hardware **#E** x 8pcs

Insert bolts (#B) with Washers (#D,#E). Align the rails to the Headboard (#1) and Footboard (#2) and secure by tightening the bolts.

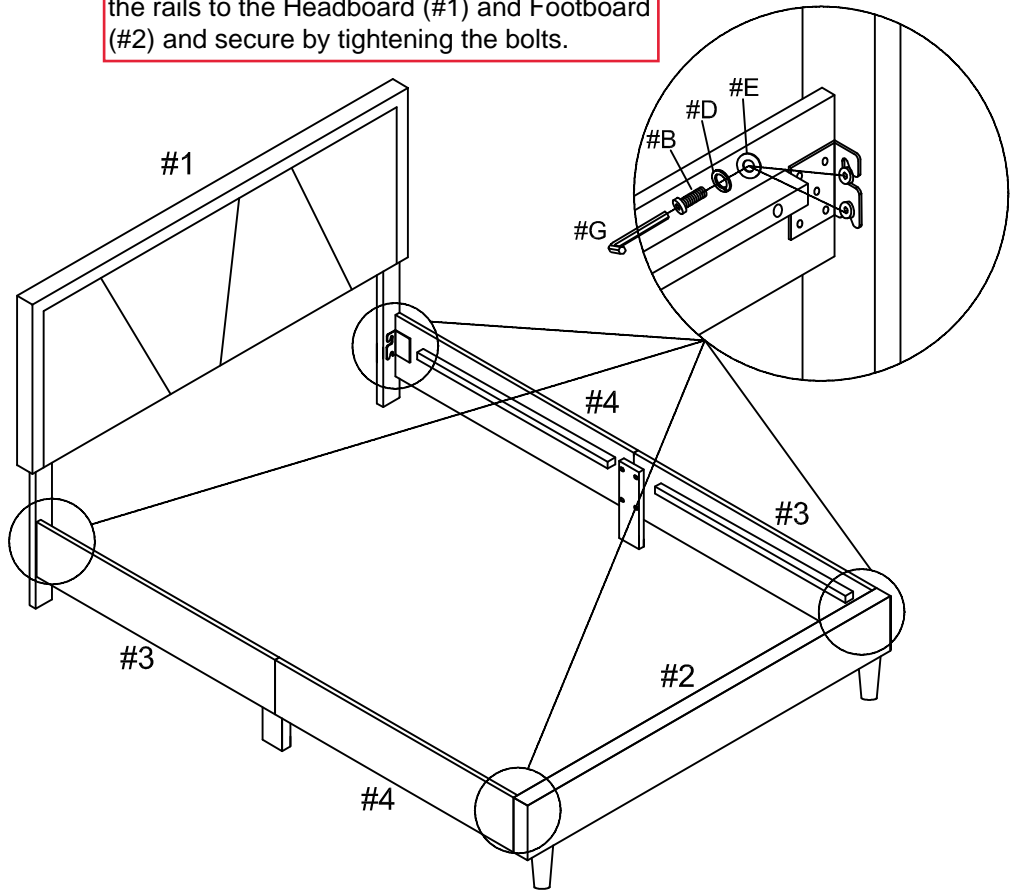

5

- Part **#7** x2pcs
- Part **#8** x2pcs
- Hardware **#C** x 2pcs
- Hardware **#D** x 2pcs
- Hardware **#E** x 2pcs
- Hardware **#F** x 6pcs
- Hardware **#H** x 1pc

Align both Center Support tubes (#8) and secures together using the connect plate (#H) and Screws (#F). Attach the Support leg (#7) to the Center Support Tube (#8) by using Bolts (#C) with washers (#D,#E).

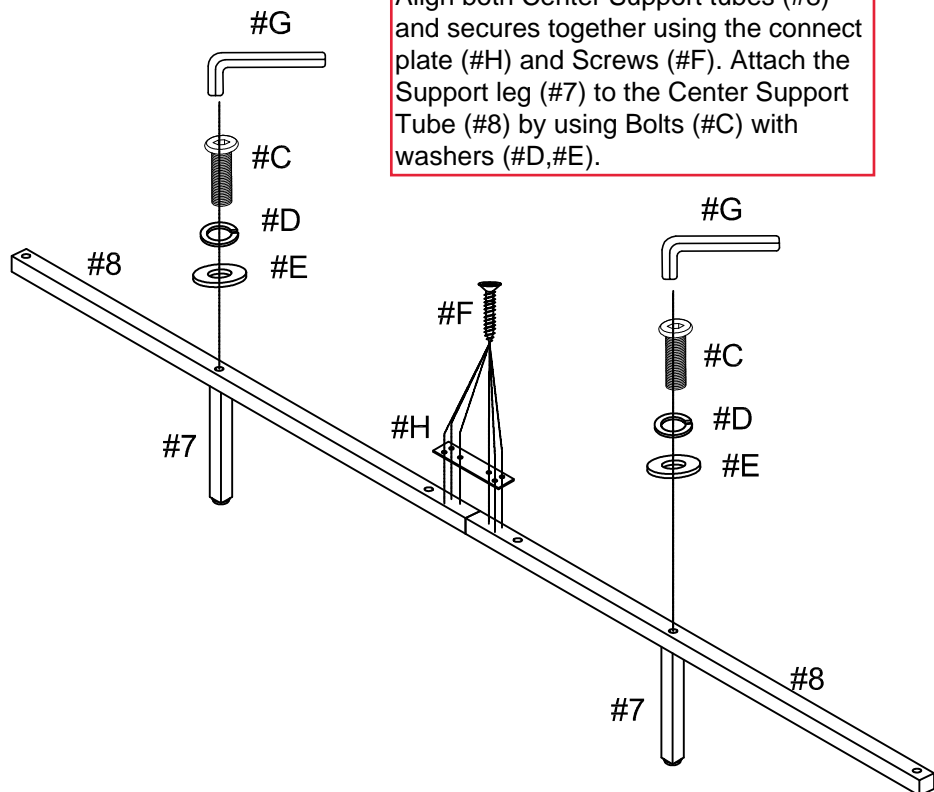

ASSEMBLY INSTRUCTIONS

6

- Part #7 x4pcs
- Part #10 x1Set
- Hardware #C x 4pcs
- Hardware #D x 4pcs
- Hardware #E x 4pcs

Align the Support Leg (#7) and Center Support Tube (#8) to the Slats (#10) as shown in the diagram. Secure using Bolts (#C) with Washers (#D, #E). Align the Slats to the Rails (#3,#4).

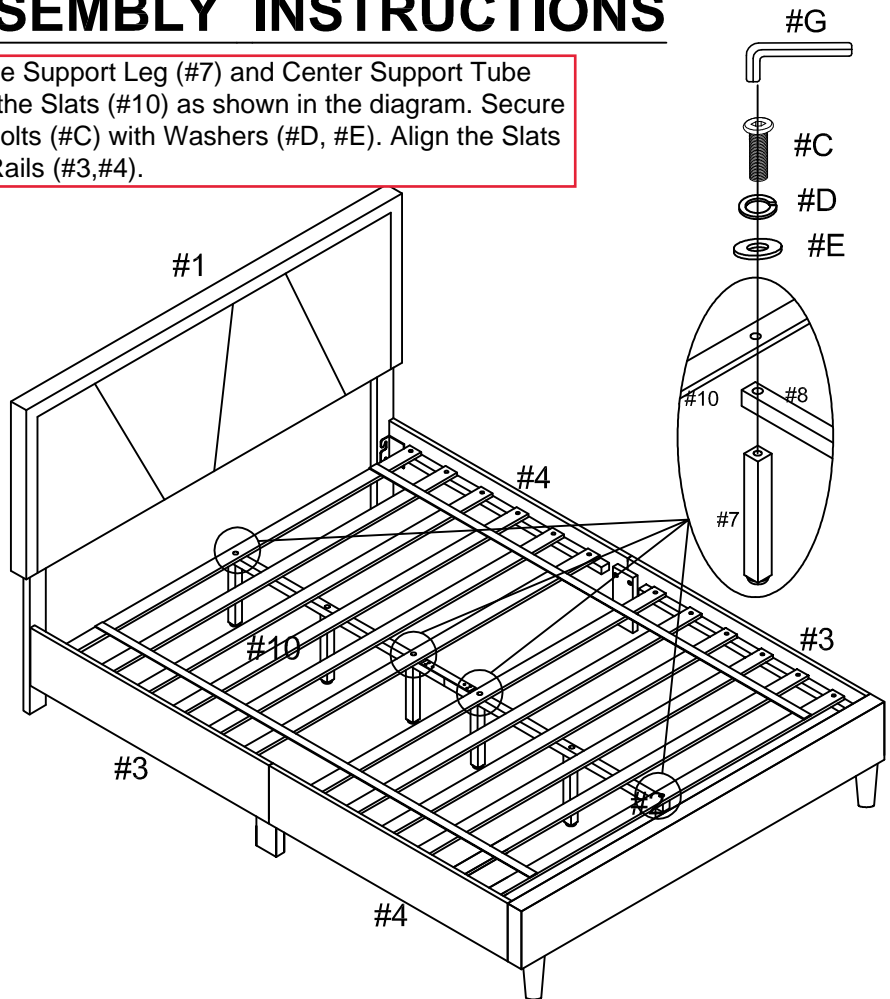

7

- Hardware #F x 24pcs

Secure the slats to the side rails using Screws (#F).

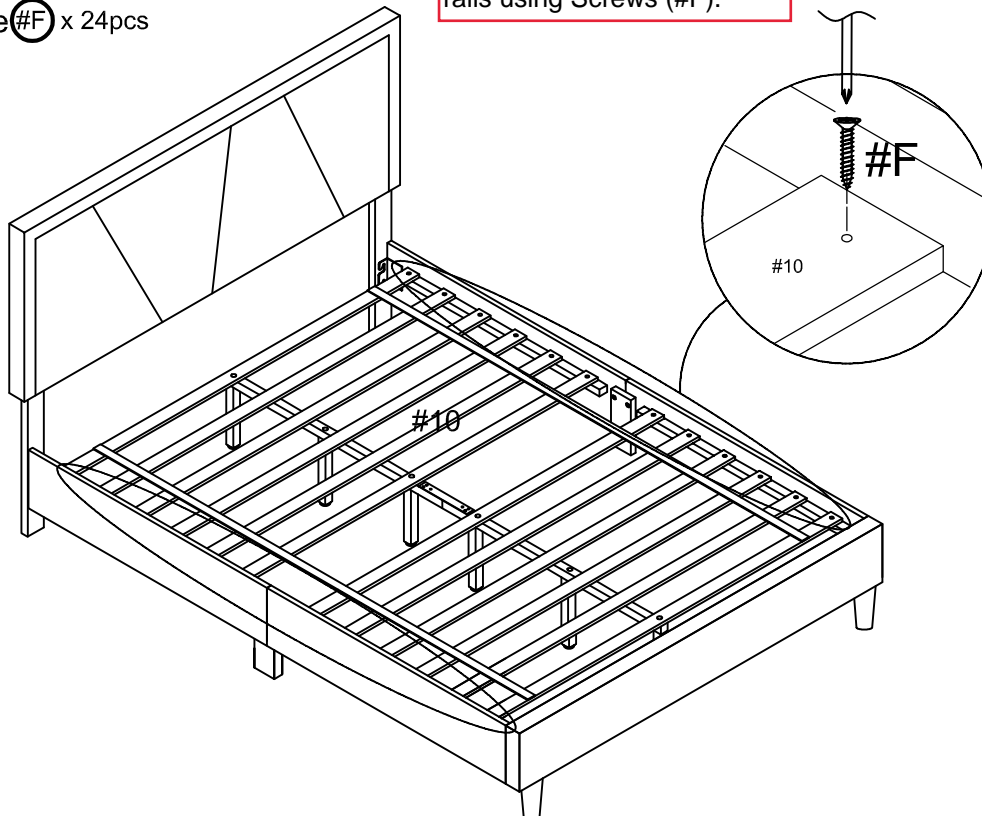

ASSEMBLY INSTRUCTIONS

8

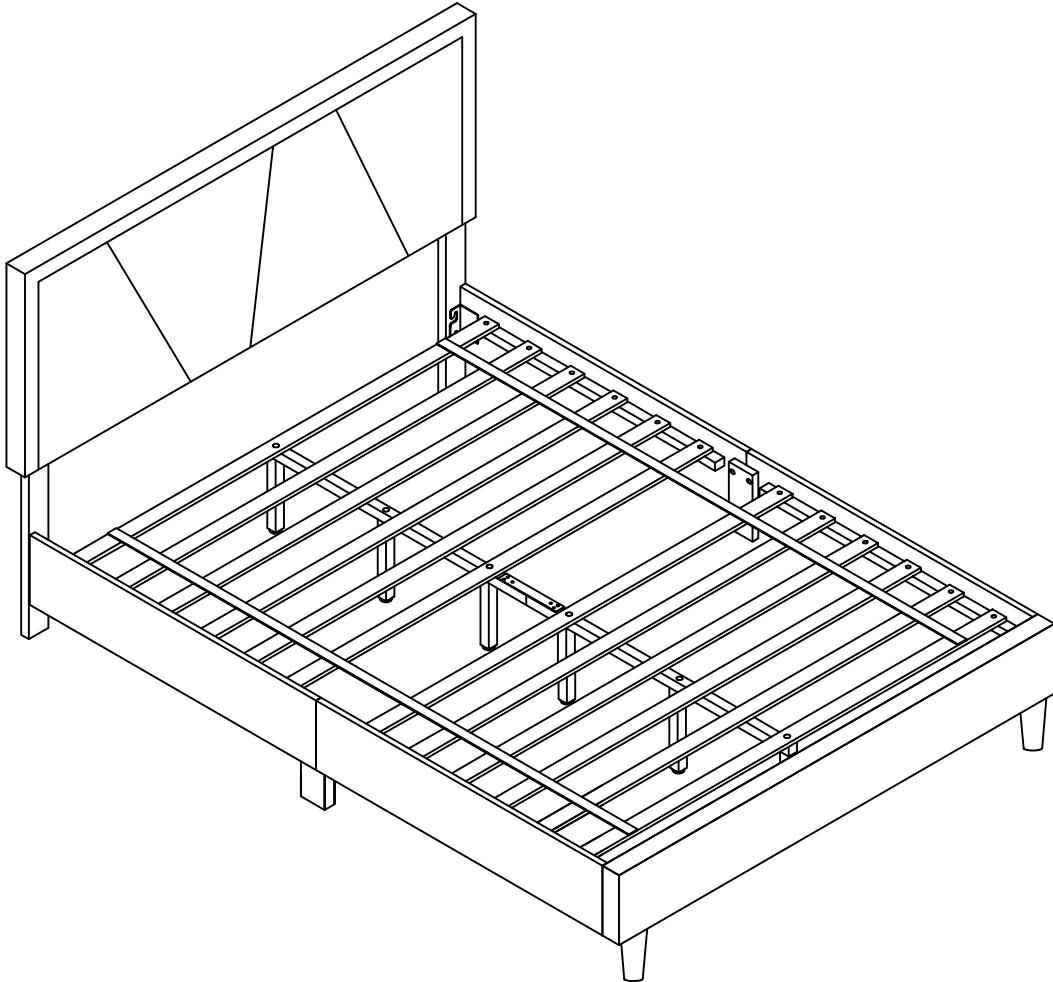

ASSEMBLY COMPLETED



Please ensure the furniture rests on an even and flat surface. If the product wobbles or feels loose, double-check all bolts and/or screws are properly tightened and secured.



Keep this handy!

Please retain this instruction manual and any order-related information for future reference.



Lift, don't drag!

To avoid damage to product please always LIFT the product when transporting or adjusting the placement.