

ASSEMBLY INSTRUCTIONS

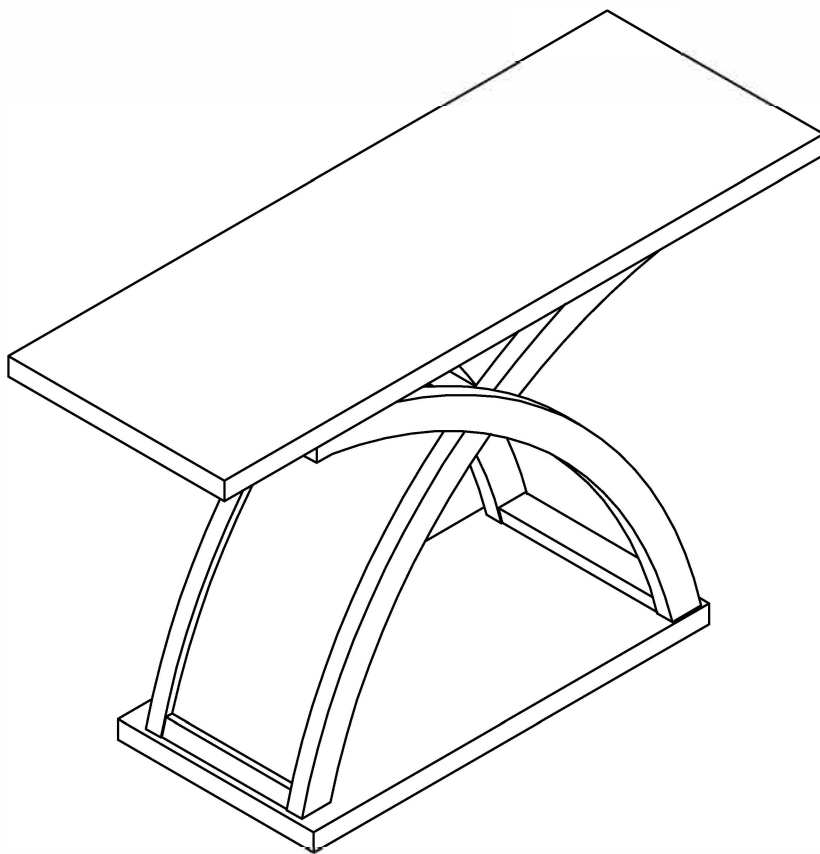

TOOLS REQUIRED



Allen Wrench

(Included)



**Philips
Screwdriver**

(Not Included)



**2 - Persons
Recommended**

ASSEMBLY RATING



EASY —————> DIFFICULT

The Assembly Rating is a 5-point system showing the level of effort needed to assemble a specific product.



CHECK BEFORE STARTING

Are you missing anything?

Double-check all parts, hardware and accessories listed on Page 6 are accounted for.

Check out our Quick Tips!

We recommend reviewing the pre-assembly handouts. Even experts need a refresher now and then!

Should we send any replacements?

Are there any irregularities or flaws in the parts? We can send replacements!

Prep Time!

Please review the assembly instructions and all diagrams prior to assembling. Arrange parts as recommended on Page 7 and group identical hardware together to make assembling easier.

PRE ASSEMBLY INTRODUCTION

We understand building ready-to-assemble furniture can be a challenging experience for some. To help avoid confusion, we have provided some helpful tips that may speed up the process.

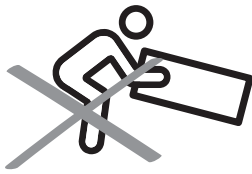

Teamwork

ALWAYS have at least two people to help with transporting and assembling the product to avoid potential injury and/or damage.

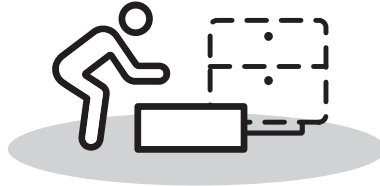

Suitable Location

Assembling near the area of the intended location is highly recommended.



Sufficient Space

Make sure you have enough space to move around during the assembly.



Avoid Scratches

Use cardboard, blankets or a carpeted area while assembling furniture to prevent scratches.

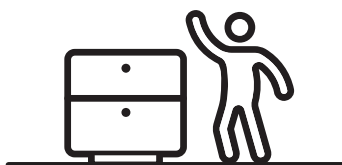
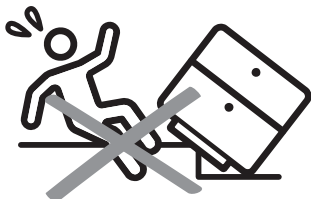

Flat Surface

Make sure the furniture rests on a flat and level surface with each leg evenly touching the floor.

ASSEMBLY AND CARE ADVICE



FAILURE TO FOLLOW THE GUIDELINES BELOW MAY RESULT IN INJURY AND/OR PROPERTY DAMAGE.



Position each part correctly and insert screws or bolts into their respective holes.

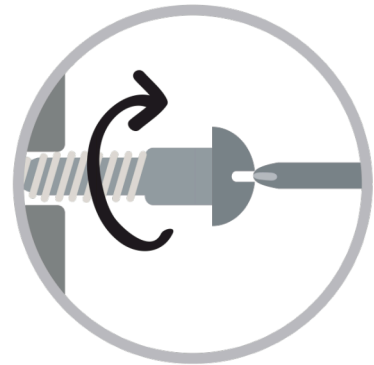

Turn clockwise to tighten and only tighten when step is completed or when instructed to do so.



Use the appropriate hand tools or power tools for assembly. Select steps, such as tightening screws and/or bolts, may require hand tools to avoid causing damage during assembly.



Save the instructions and store any supplied tools for later maintenance.

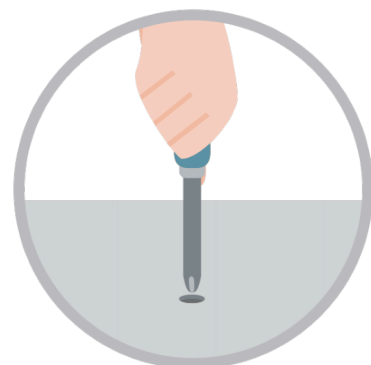

After two weeks, check and tighten any loose hardware and repeat again every six months thereafter.

IT IS THE USER'S RESPONSIBILITY TO MAINTAIN THE FURNITURE. THE HARDWARE MAY LOOSEN OVER TIME AND MAY CAUSE THE FURNITURE TO BE WOBBLY AND UNABLE TO SUPPORT ITS INTENDED WEIGHT CAPACITY. THIS MAY LEAD TO COLLAPSE AND MAY CAUSE SERIOUS INJURY.

SOFA TABLE

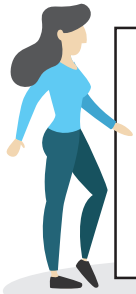

- Please keep instructions for future reference.
- Check the quantity and irregularity of parts and hardware before you start.

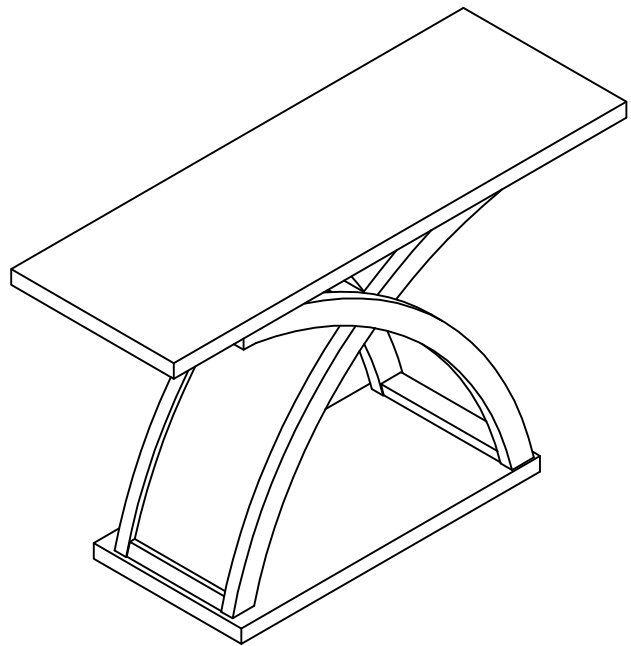

PARTS

#1 1pc

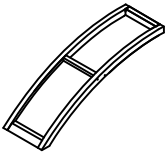

Inside cross leg

#2 1pc



Outside cross leg

#3 1pc

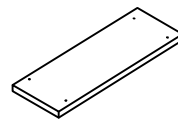

Base

#4 1pc

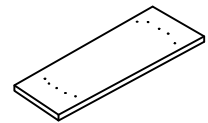

Top Panel

HARDWARE

#A 6pcs



Flat head screw Ø6x35

#B 4pcs



Sticker Ø20

#C 4pcs



Washer Ø17x2

#D 6pcs



Dowel Ø8x25

#E 4pcs



Self-Tapping Screw
Ø4x50

#F 4pcs



Wood screw
Ø7x58

#G 1pc



Glue

#H 4pcs



Foot Tack

ACCESSORIES

A1 1pc



Antitipstrap 197X5X1

A2 1pc

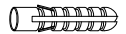

Plastic Anchor 8X40

A3 2pcs



Metal Bracket 12X12X1

A4 1pc

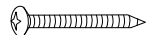

Wall Screw 5X40

A5 2pcs

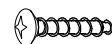

Extra Small Screw 4X25

ASSEMBLY INSTRUCTIONS

1

- Part #1 x1pc
- Part #2 x1pc
- Hardware #A x4pcs
- Hardware #B x4pcs

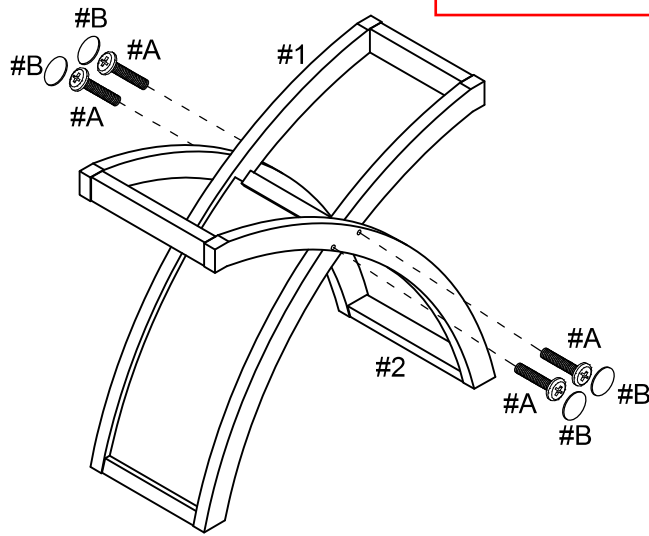

Align cross legs (#1,2) to each other, then secure by using bolts (#A) and stickers (#B).

Tip: Place parts on the flat level surface to ease alignment and assemble.

2

- Part #4 x1pc
- Hardware #A x2pcs
- Hardware #D x4pcs
- Hardware #E x4pcs

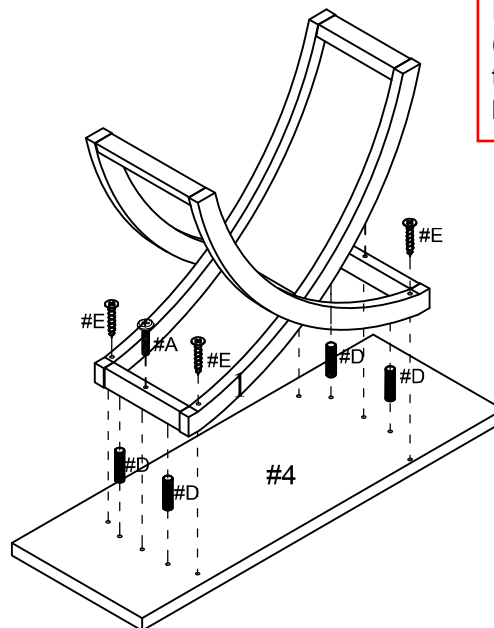

Insert dowels (#D) to the top panel (#4), then align the cross legs to the top panel (#4). Secure by using bolts (#A) and screws (#E).

ASSEMBLY INSTRUCTIONS

3

- Part #3 x1pc
- Hardware #C x4pcs
- Hardware #D x2pcs
- Hardware #F x4pcs

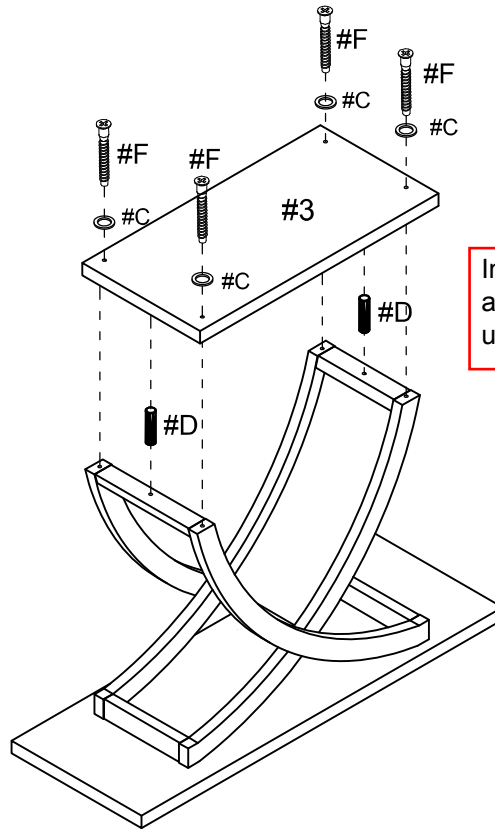

Insert dowels (#D) to the cross legs, then align base (#3) to the cross legs. Secure by using bolts (#F) with washers (#C).

4

- Hardware #H x4pcs

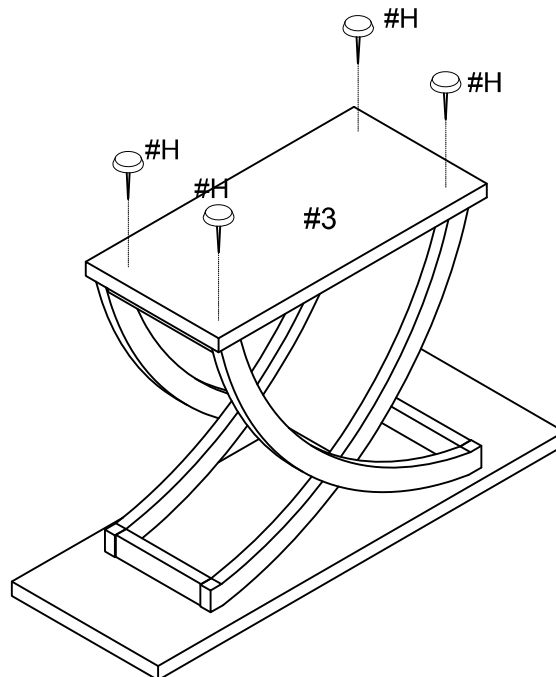

Hammer in the floor protectors (#H) to the base (#3).

Tip: Utilize the soft Styrofoam sheet from the packaging or any smooth soft blanket under the product to prevent scratches.

ASSEMBLY INSTRUCTIONS

5

Accessories **A1** x 1pc

Accessories **A2** x 1pc

Accessories **A3** x 2pcs

Accessories **A4** x 1pc

Accessories **A5** x 1pc

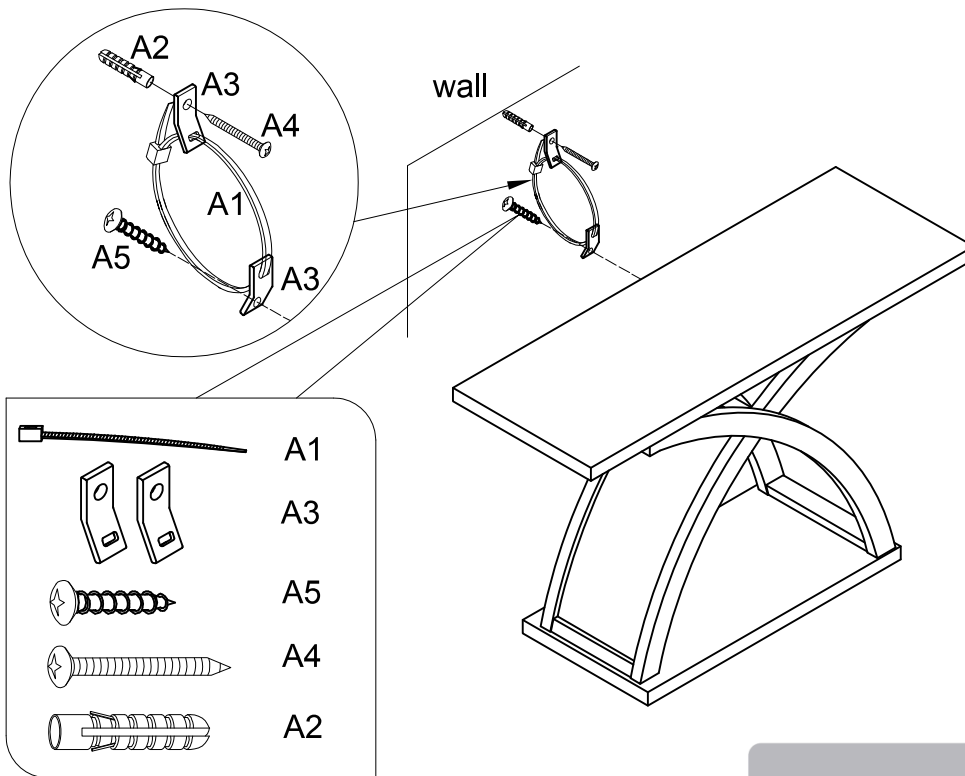

ASSEMBLY COMPLETED



Please ensure the furniture rests on an even and flat surface. If the product wobbles or feels loose, double-check all bolts and/or screws are properly tightened and secured.



Keep this handy!

Please retain this instruction manual and any order-related information for future reference.

ASSEMBLY INSTRUCTIONS

Wall Mounting and Fixing



EXPANSION WALL ANCHOR

Our provided expansion wall anchors are only suitable for masonry walls, such as drywall, plaster or concrete, and are best for holding lightweight items or for anti-tip prevention. If you are unsure of the correct wall anchor to use with the product, please request professional guidance. Liability for product damage or failure due to using the incorrect anchors will fall on the installer.

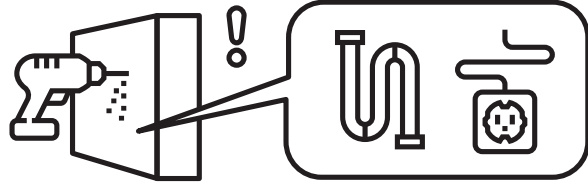

CHECK BEFORE PROCEEDING

Prior to drilling or hammering, please check for wires or pipes. We recommend using a stud finder to locate a stud, which will offer more appropriate resistance and hold more weight.

QUICK TIPS

1. If unsure of the proper size, always choose a larger screw and wall anchor.

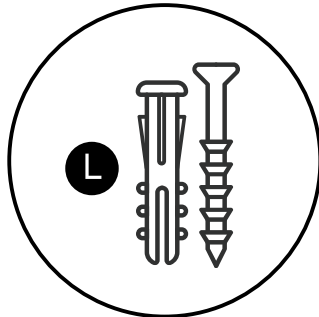

2. Match the drill bit to the wall anchor and hole size.

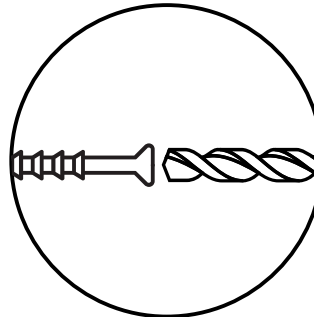

3. Only drill horizontally. Do not force the drill or enlarge the hole for the wall anchor.

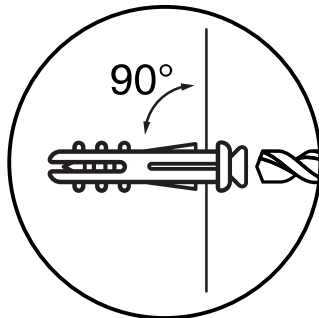

4. Take extra care when drilling into high walls or ceramic tiles. Wall anchors should be a tight fit for the hole. Never use wall anchors in ceilings.

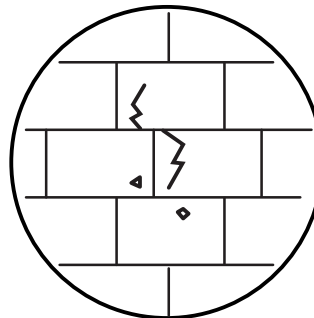

MAINTENANCE



Yearly
Check

We recommend a yearly check to see if the wall anchor or screw has loosened. If so, please remove the existing wall anchor and screw, and use a new anchor.